

OWNER'S MANUAL

DieHard®

BATTERY CHARGER
10/2 Amp
Automatic

ENGINE START
50 Amp

Model No.
200.71222

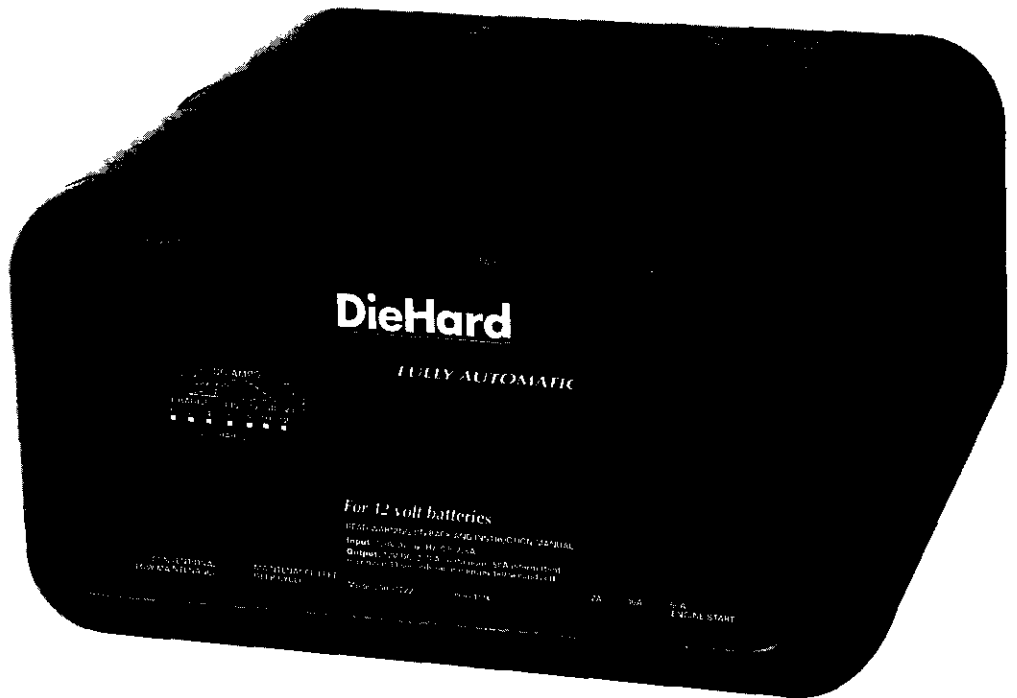

CAUTION:
Read all Safety Rules and Operating Instructions,
and follow them with each use of this product.

Sears, Roebuck and Co., Hoffman Estates, IL 60179 U.S.A.

Table Of Contents

Warranty	1	Setting the controls	6
Important Safety Instructions	2	Ammeter	6
Parts	3	Charging your battery in vehicle	7
Before Using Your Battery Charger	4	Charging your battery out of vehicle	8
Plugging it in	4	Calculating charge times	9
Using an extension cord	4	Using the engine start	10
Preparing your battery to be charged	5	Maintenance and care	10
Using Your Battery Charger	6	Troubleshooting	11

Please read this Owner's Manual before using your Battery Charger

The DieHard model 71222, Manual Battery Charger/Engine Starter, offers a wide range of features to accommodate the needs for home or light commercial use. This manual will show you how to use your charger safely and effectively. Please read and follow these instructions and precautions carefully.

For information about troubleshooting, call toll-free from anywhere in the U.S.A. 7 am to 4:30 pm CT Monday through Friday.

1-800-SEARS-64 (1-800-732-7764).

Warranty

FULL THREE-YEAR WARRANTY

If, within three years from the date of purchase this battery charger fails due to a defect in material or workmanship, simply return the charger to the place of purchase and it will be replaced free of charge.

This warranty gives you specific legal rights, and you may also have other rights which vary from state to state.

Sears, Roebuck and Co., Dept 817WA,
Hoffman Estates, IL 60179

Important Safety Instructions

– SAVE THESE INSTRUCTIONS –

WARNING

To reduce the risk of explosion, explosive gases, or injury while using your battery charger, follow the precautions listed below:

- Read all instructions and cautions printed on the battery charger, battery, and vehicle or equipment using battery.
- Use charger only on lead-acid type rechargeable batteries, such as those used in cars, trucks, tractors, airplanes, vans, RV's, trolling motors, etc. This charger is not intended to supply power to a low voltage electrical system other than in an automotive application.
- Use only attachments recommended or sold by manufacturer. The use of attachments not recommended by the manufacturer may result in fire, electric shock, or injury.
- Do not disassemble charger. Take it to a qualified service professional if service or repair is required. Incorrect assembly may result in fire or electrical shock.
- To reduce risk of electrical shock, unplug the charger from the outlet before attempting any maintenance or cleaning.
- Always charge battery in a well ventilated area.

Help us help you

Remember:

- Place charger as far away from battery being charged as the charger cables will permit.
- Do not expose charger to rain or snow.
- Never charge a frozen battery. If battery fluid (electrolyte) becomes frozen, bring battery into a warm area to thaw before you begin charging.
- Never allow battery acid to drip on charger when reading specific gravity or filling battery.
- Never set a battery on top of the charger.
- Never place charger directly above battery being charged. The gases from the battery will corrode and damage the charger.
- Never use charger for charging dry-cell batteries that are commonly used with home appliances. These batteries may burst and cause personal injury.
- Never touch the battery clamps together when the charger is energized.
- Never operate charger if it has received a hard blow, been dropped, or otherwise damaged. Take it to a qualified professional for inspection and repair.
- Be sure to position the charger power cord to prevent it from being stepped on, tripped over, or damaged.
- Never pull out the plug by the cord when unplugging the charger. Pulling on the cord may cause damage to the cord or the plug.
- Do not operate the charger if it has a damaged power cord or plug. Have the cord replaced.

Personal Safety Precautions

For your own personal safety, please follow the following precautions:

- Wear complete eye and clothing protection when working with lead-acid batteries.
- Be sure that someone is within range of your voice to come to your aid if needed, while you work with or are near a lead-acid battery.
- Have plenty of fresh water and soap nearby for use in case battery acid contacts your eyes, skin, or clothing. If this happens, wash immediately with soap and water. Then get medical attention.
- Avoid touching your eyes while working with a battery. Acid particles (corrosion) may get into your eyes. If this occurs, flush eyes immediately with running cold water for at least 10 minutes. Then immediately get medical attention.
- Remove all personal metal items from your body, such as rings, bracelets, necklaces, and watches while working with a lead-acid battery. A battery can produce a short circuit current high enough to weld a ring (or the like) to metal, causing a severe burn.
- Take care not to drop any metal tool or metal object onto the battery. This may spark or short circuit the battery or another electrical device that may cause an explosion.
- Always operate your battery charger in an open, well ventilated area.
- Never smoke or allow a spark or flame in the vicinity of the battery or engine. Batteries generate explosive gases.
- Neutralize any acid spills thoroughly with baking soda before attempting to clean up.

Parts

This section shows an illustration of your battery charger. Use it to become familiar with where all the parts are located, and what they look like.

Replacement Parts List DieHard 71222		
Item	Description	Part Number
1.	Cover	3799001402
2.	Heat Sink Assembly	2299000950
3.	Base	3799001382
4.	AC Power Cord	90026058
5.	Transformer	93026525
6.	Output Cable	3899000515
7.	Circuit Breaker (35A)	3899000072
8.	50A Clamp (1)	2299000248
	Red Sleeving (2) Required	0399000007
	Black Sleeving (2) Required	0399000008
9.	Meter	5399100093
10.	Switch SPDT	0499000032
11.	Front Panel	3799002292
12.	Decal	0899001724
13.	Handle	3599000240
14.	Screw 8-18 x 3/8" (4)	5181803269
15.	Owner's Manual	0099000310
16.	Switch DPTT	0499000066
17.	Control Board	2299000906

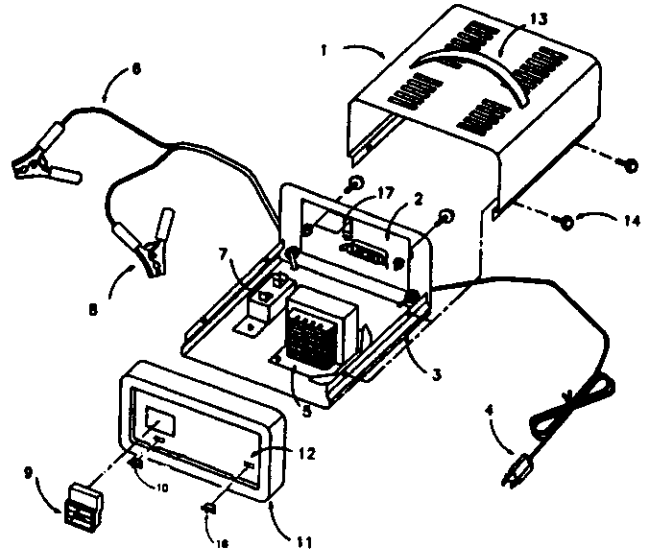

Wiring Diagram

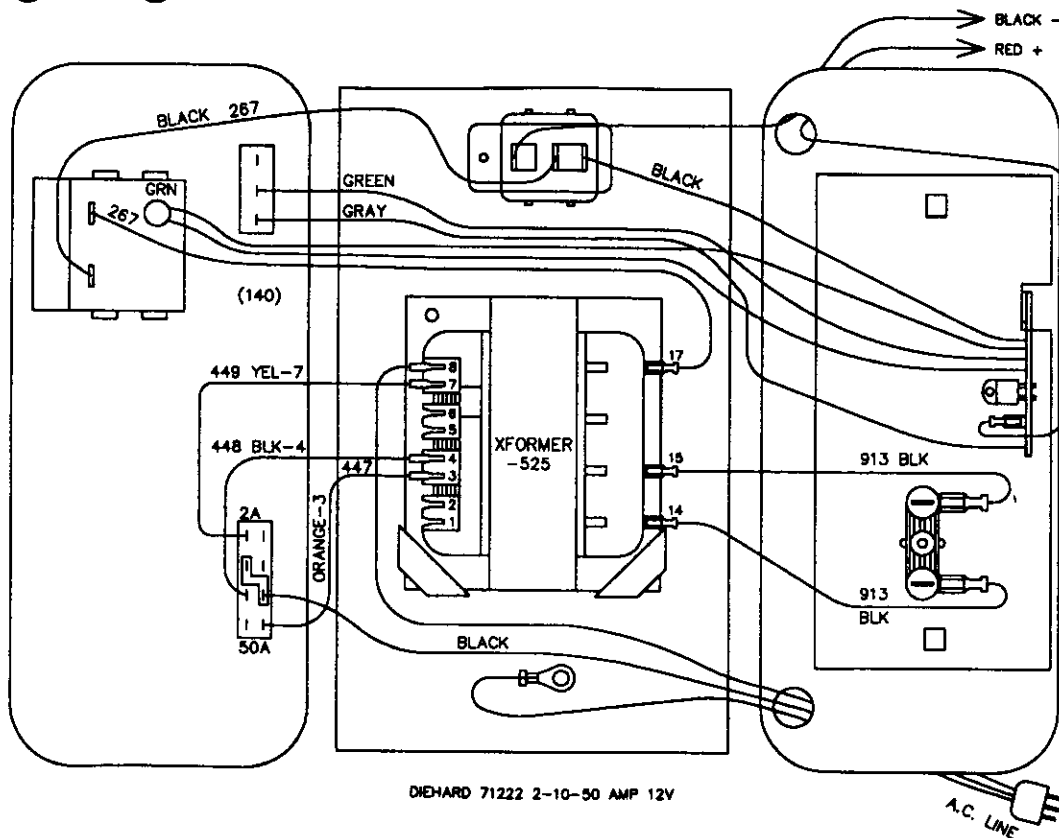

Before Using Your Battery Charger

It is important to understand your charger's requirements. This section will tell you about your charger's electrical requirements and how to prepare a battery for charging.

Plugging it in

WARNING

Electrical Shock Hazard

Be sure that power cord fits properly into outlet. If not, have a qualified technician install a proper outlet. Never alter the AC cord or plug provided. Improper connection can result in electrical shock.

Your charger should be grounded to reduce the risk of electrical shock.

Your charger is equipped with an electrical cord that has an equipment grounding conductor and a grounding plug designed to be used on a 120 volt circuit. The plug must be plugged into an outlet that has been properly installed and grounded in accordance with all local codes and ordinances.

A **TEMPORARY** adapter may be used to connect the charger to a two-pole outlet if a properly grounded outlet is not available. Use the adapter **ONLY** until a properly grounded outlet can be installed by a qualified electrician.

 **WARNING: Improper adapter connection can result in electrical shock.**

Before using an adapter as illustrated, be certain that the center screw of the outlet plate is grounded. The green colored grounding clip of the adapter must be attached by a metal screw to a properly grounded outlet. If unsure whether outlet is properly grounded, contact a professional electrician. If necessary, replace the original outlet cover screw with a longer one that will secure the grounding clip to the outlet cover and make a ground connection to the grounded outlet.

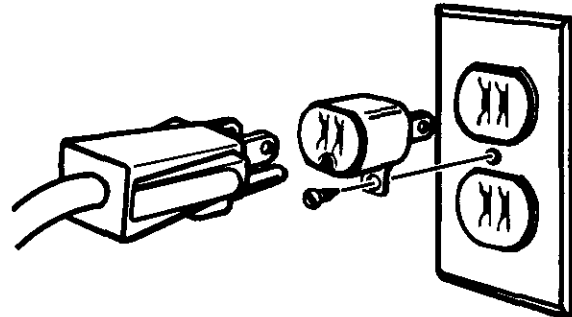
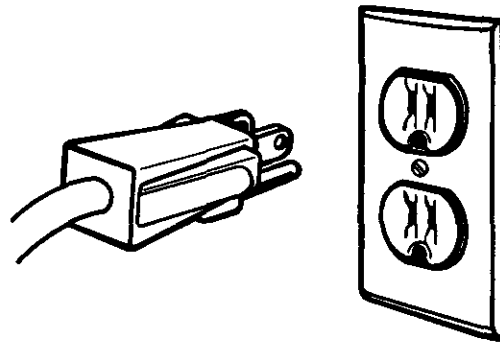

Using an extension cord

The use of an extension cord is not recommended. If you must use an extension cord, please make sure that you follow these guidelines:

- Make sure that the pins on charger's power cord fit firmly into the extension cord, and that the extension cord fits firmly into the receptacle.
- Use only 3-conductor (grounded)
- Check that the extension cord is properly wired and in good electrical condition.
- Make sure that the wire size is large enough for its length and for the AC ampere rating as specified in the accompanying chart.

MINIMUM RECOMMENDED EXTENSION CORD				
Length of Cord, in Feet	25	50	100	150
AWG* Size of Cord	18	18	16	14

*AWG=American Wire Gauge

Preparing your battery to be charged

It is important that you read and follow these guidelines while you are preparing to charge your battery.

- Make sure that you have a 12 volt lead-acid battery.
- Clean the battery terminals. Be careful to keep corrosion from getting in or around your eyes.
- If you have a battery with removable cell caps, if required, add distilled water to each cell until the battery acid reaches the level indicated by the manufacturer. This will help purge excessive gases from the cells. Be careful not to overfill. If you have a sealed battery without cell caps, no action is necessary. Continue to the next step listed below.
- Take time to read all battery manufacturer's specific precautions, such as removing or not removing cell caps while charging, and recommended rates of charge.
- Wear safety glasses. See additional "Personal Safety Precautions" on page 2.
- Be sure that the area around the battery is well ventilated while it is being charged. If ventilation is poor, gas can be manually blown away by using a piece of cardboard or other non-metallic material as a fan.
- If it is necessary to remove the battery from the vehicle to charge it, always remove the grounded terminal from the battery first. A spark may be caused if all accessories in the vehicle are not completely turned off.

NOTE: A marine battery installed in a boat must be removed and charged on shore.

Using Your Battery Charger

For best results from your battery charger, learn to use it properly. This section tells how to set the controls and how to charge a battery in and out of the vehicle.

Setting the controls

All the controls for your charger are located on the front of the charger. Follow these instructions to obtain the correct charge level for your battery.

SELECTOR SWITCHES

Two switches are used to select the type and rate of charge.

- Use the right switch to select the 2-amp, the 10-amp charge rate or the 50-amp Engine Start feature.
- Use the left switch to select the type of battery: conventional/low maintenance or maintenance free/deep-cycle.
- Use the 2-amp setting to charge small batteries and the 10-amp setting for larger batteries.

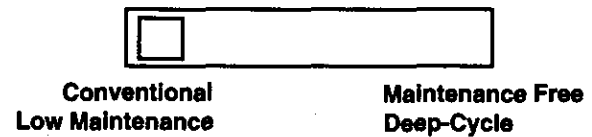
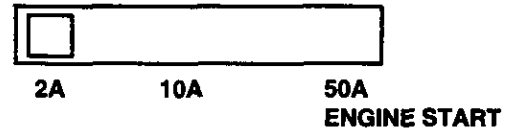

AMMETER

The ammeter indicates the measured amount of amperes being drawn by the battery. When you first start charging a battery, the reading will be high, with the needle near 10 amps using the 10 amp charging rate. As the battery charges, the needle will begin to fall toward 0. When the battery is fully charged, the needle will point to 0 and the **FULL CHARGE** green LED will glow.

The percent of charge scale is intended as a visual aid to simplify reading the state of charge of the battery. The meter is scaled for use with the 10 amp charge rate. For the 2 amp charge rate, use the red triangle as your reference. When charging for 2 amps, the needle will begin close to the "R" on **RATE** and will drop to 0 when finished.

The percent of charge is based on current drawn by the battery. For this reason, accuracy will vary with the size and battery type.

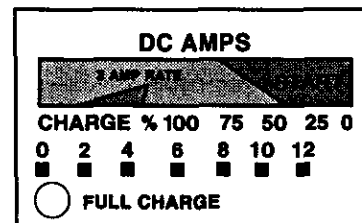

Charging Your Battery

Charging your battery in the vehicle:

1. Arrange the power cord and charging leads carefully in order to avoid damage that could be caused by the hood, door, or moving engine parts.
2. Keep clear of the fan blades, belts, pulleys, and other parts that can cause injury.
3. Check the polarity of the battery posts as indicated on the battery case: POSITIVE (POS, P, or +) and NEGATIVE (NEG, N or -). NOTE: The positive post on top-post batteries is usually larger than the negative post.
4. Identify which battery post is ground or connected to the chassis. **THE NEGATIVE POST IS NORMALLY THE ONE THAT IS GROUNDED.**
5. **To charge a negative grounded post system:** Connect the red (POSITIVE) battery charger clamp to the ungrounded POSITIVE (POS, P, +) post of the battery. Then connect the black (NEGATIVE) clamp to a heavy, unpainted metal part of the chassis or engine block, away from the battery. Do not connect clamp to carburetor, fuel lines, or sheet metal parts.
To charge a positive grounded post system: Connect the black (NEGATIVE) battery charger clamp to the NEGATIVE (NEG, N, -) ungrounded post of the battery. Then connect the red (POSITIVE) clamp to a heavy, unpainted metal part of the chassis or engine block. Do not connect clamp to carburetor, fuel lines, or sheet metal parts.
IMPORTANT: Wear safety glasses and face away from the battery while making connections.
6. Connect the clamp to the battery post and twist or rock back and forth to make a solid connection. This will help keep the clamps from slipping off the posts and causing sparks.
7. Select the type and rate of charge with the Selector switch.
8. Plug the power cord into a grounded AC outlet to begin charging.
9. When the battery is fully charged, unplug the charger power cord before attempting to disconnect charger clamps.
10. Standing away from the battery, remove the charger clamps **in this order:** (1) from the chassis connection and, (2) from the battery post or terminal.
11. Clean and store the battery charger in a dry location.

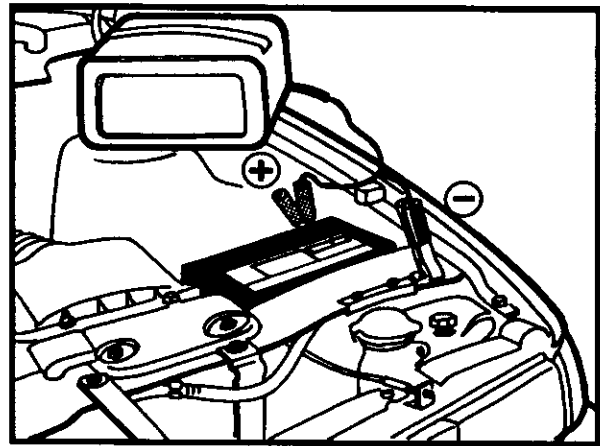

NEGATIVE GROUNDED SYSTEM

Charging your battery outside the vehicle:

1. Remove the battery from vehicle, making sure to disconnect grounded terminal first with all accessories and lights turned off in the vehicle.
2. Check the polarity of the battery posts as indicated on the battery case: POSITIVE (POS, P, +) and NEGATIVE (NEG, N, -).

NOTE: On top-post batteries, the positive battery terminal usually has a larger diameter than the negative one.

3. Connect the red (POSITIVE) charger clamp to the POSITIVE post of the battery. Be sure to rock the clip back and forth to make a solid connection.
4. Attach a 6-gauge (AWG) or a 4-gauge (SAE) insulated battery cable of at least 24-inches in length to the NEGATIVE battery post. This cable will provide a safer connection because arcing and sparking will not occur directly over the battery. (The battery cable is not provided with the charger, but may be purchased at most automotive accessory outlets.)
5. Take the other end of the 6-gauge (AWG) or a 4-gauge (SAE) insulated 24-inch cable and, standing as far away from the battery as possible, connect the black (NEGATIVE) lead of the charger to the free end of the cable. Rock the clamp to make a solid connection.

IMPORTANT: Wear safety glasses and face away from the battery while making this final connection.

6. Select the type and rate of charge with the Selector Switch.
7. Plug the power cord into a grounded AC outlet to begin charging.
8. When the battery is fully charged, unplug the charger power cord before attempting to disconnect charger clamps.
9. Stand away from the battery and remove the charger leads from the NEGATIVE connection first, then from the POSITIVE battery post.
10. Clean and store the battery charger in a dry location.

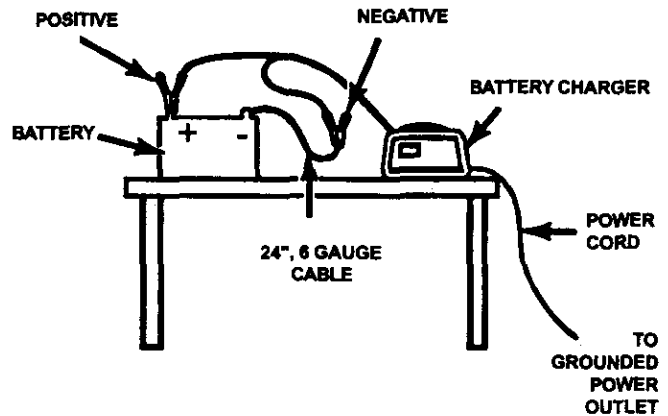

Calculating charge times

The Chart Method

Use the following table to more accurately determine the time it will take to bring a battery to full charge. First, identify where your battery fits into the chart.

- Small batteries — motorcycles, garden tractors, etc. — are usually rated in Ampere Hours (AH). For example: 6 to 12 AH, or 12 to 32 AH.
- Batteries in cars and smaller trucks are usually rated in Reserve Capacity (RC), Cold-Cranking Amps (CCA), or both.

- Marine, or deep-cycle batteries are usually rated in Reserve Capacity (RC).
- **NR** means that the charger setting is **NOT RECOMMENDED**.

Find your battery's rating on the chart below and note the charge time given for each charger setting. The times given are for batteries with a **50-percent charge**. Add more time for totally discharged batteries.

BATTERY SIZE/RATING			CHARGE RATE/CHARGING TIME - HOURS	
			2 AMP	10 AMP
SMALL BATTERIES	Motorcycle, garden tractor, etc.	6 - 12 AH	2 - 4	NR
		12 - 32 AH	4 - 10	NR
CAR/TRUCKS	200 - 315 CCA	40 - 60 RC	11 - 14	2 - 2 ⁷ / ₈
	315 - 550 CCA	60 - 85 RC	14 - 18	2 ⁷ / ₈ - 3 ³ / ₄
	550 - 1000 CCA	85 - 190 RC	18 - 35	3 ³ / ₄ - 7
MARINE/DEEP CYCLE		80 RC	18	3 ¹ / ₂
		140 RC	27	5 ¹ / ₂
		160 RC	30	6
		180 RC	33	7

The Hydrometer or Electronic Method

To find the time needed to fully charge your battery, determine the battery's charge level with a hydrometer or electronic Percent-of-Charge Tester. The following table will help you convert hydrometer readings to percent of charge values.

SPECIFIC GRAVITY	PERCENT OF CHARGE	PERCENT OF CHARGE NEEDED
1.265	100%	0%
1.225	75%	25%
1.155	25%	75%
1.120	0%	100%

When you know the percent of charge and the Amp Hour (AH) rating of your battery, you can calculate the approximate time needed to bring your battery to a full charge.

To convert Reserve Capacity to Amp Hours, divide Reserve Capacity by 2, and add 16:

$$\text{Amp Hours} = \frac{\text{Reserve Capacity}}{2} + 16$$

To calculate time needed for a charge:

- Find the percent of charge needed. (A battery at 50 percent charge that will be charged to 100 percent needs another 50 percent (.50).
- Multiply the Amp Hour rating by the charge needed (.50) and divide by the charger setting (2 or 10 amps).
- Multiply the result by 1.25 and you'll have the approximate time needed, in hours, to bring the battery to full charge.
- Add one additional hour for a deep-cycle battery.

Example:

$$\frac{\text{Amp Hour Rating} \times \% \text{ of charge needed} \times 1.25}{\text{Charger Setting}} = \text{hours of charge}$$

$$\frac{100 \text{ (AH Rating)} \times .50 \text{ (charge needed)} \times 1.25}{10 \text{ (Charger Setting)}} = 6.25 \text{ hours}$$

$$\frac{100 \times .50}{10} = 5 \times 1.25 = 6.25$$

You would need to charge your 100-Ampere Hour Battery for approximately 6¹/₄ hours at the 10-Amp charge rate using the above example.

Using the engine start feature

Your battery charger can be used to jump-start your car if the battery is low. Follow these instructions on how to use the ENGINE START feature.

1. Connect the charger to the battery. (Follow connecting instructions given in "Charging Your Battery in the vehicle" on page 7.
2. Select the Selector Switch on ENGINE START.
3. Crank the engine for **no more than 10 seconds**. If it does not start, **wait at least four minutes** before cranking again. In extreme cold, or if the battery is severely discharged, charge the battery for about 5 minutes in the 10 amp position before cranking the engine.
4. After the engine starts, unplug the charger power cord from the AC outlet. Then disconnect the charger from the battery.

IMPORTANT: Do not try to start the engine without a battery in it. You could cause damage to the electrical system.

If the engine does turn over, but never starts up, there is not a problem with the starting system, there is a problem somewhere else in the engine. **STOP** cranking the engine until the other problem has been identified and corrected.

Maintenance and care

A minimal amount of care can keep your battery charger working properly for years.

1. Clean the clamps each time you are finished charging. Wipe off any battery fluid that may have come in contact with the clamps to prevent corrosion.
2. Coil the input and output cords neatly when storing the charger. This will help prevent accidental damage to the cords and charger.
3. Occasional cleaning of the case of the charger with a soft cloth will keep the finish shiny and help prevent corrosion.

Troubleshooting

Performance problems often result from little things that you can fix yourself. Please read through this table for a possible solution if a problem occurs.

PROBLEM	POSSIBLE CAUSE	SOLUTION/REASONS
No ammeter reading.	Clamps not making good connection. 2-amp charge rate. No AC power reaching charger.	Check for poor connection at battery. Make sure clamps and posts are clean. Ammeter needle will indicate little activity at the 2-amp charge rate. Check AC outlet and extension cords for loose fitting plug. Check for open fuse or circuit breaker supplying AC outlet.
Circuit breaker in charger cycles on and off with a clicking sound.	Shorted battery clamps. Shorted battery. Charger leads reversed on battery.	Separate the clamps. Circuit breaker cycles when current draw is too high. Check for worn cables and replace if needed. Have a Sears Service Center test the battery. Correct connections.
Ammeter reads less than selected charge rate when charging.	Extension cord too long or gauge too small. Battery has weak cell or sulfated plate. Battery is partially charged.	Use shorter or heavier extension cord. Sulfated battery will eventually take a normal charge if left connected. If the battery will not take a charge, have it tested by a Sears Service Center. Continue charging battery.
Charger makes a loud buzz or hum.	Transformer laminations vibrate (buzz). Shorted diode (hum).	Continue charging. Buzz is not abnormal. Have charger tested by a Sears Service Center.
Short start cycle when cranking engine.	Drawing more than 50 amps for a period equal to or less than 10 seconds. Failure to wait for 4 minutes (240 seconds) between cranks.	Crank time varies with the amount of current drawn from the charger. If cranking draws more than 50 amps, crank time may be less than 10 seconds. Wait 4 minutes before next crank.

For information about troubleshooting, call toll-free from anywhere in the U.S.A. 7 am to 4:30 pm CT Monday through Friday.
1-800-SEARS-64 (1-800-732-7764).