



XVS650

Service Manual

YAMAHA

XVS650AK(C)

SERVICE MANUAL

**XVS650AK(C)
SERVICE MANUAL**

©1997 by Yamaha Motor Corporation, U.S.A.

First edition, August 1997

**All rights reserved. Any reproduction or
unauthorized use without the written
permission of Yamaha Motor Corporation, U.S.A.
is expressly prohibited.**

Printed in U.S.A.

LIT-11616-11-16

NOTICE

This manual was produced by the Yamaha Motor Company primarily for use by Yamaha dealers and their qualified mechanics. It is not possible to include all the knowledge of a mechanic in one manual, so it is assumed that anyone who uses this book to perform maintenance and repairs on Yamaha motorcycles has a basic understanding of the mechanical ideas and the procedures of motorcycle repair. Repairs attempted by anyone without this knowledge are likely to render the motorcycle unsafe and unfit for use.

Yamaha Motor Company, Ltd. is continually striving to improve all its models. Modifications and significant changes in specifications or procedures will be forwarded to all authorized Yamaha dealers and will appear in future editions of this manual where applicable.

NOTE:

Designs and specifications are subject to change without notice.

IMPORTANT INFORMATION

Particularly important information is distinguished in this manual by the following notations.



The Safety Alert Symbol means ATTENTION! BECOME ALERT! YOUR SAFETY IS INVOLVED!

WARNING

Failure to follow WARNING instructions could result in severe injury or death to the motorcycle operator, a bystander or a person inspecting or repairing the motorcycle.

CAUTION

A CAUTION indicates special precautions that must be taken to avoid damage to the motorcycle.

NOTE:

A NOTE provides key information to make procedures easier or clearer.

HOW TO USE THIS MANUAL

MANUAL ORGANIZATION

This manual consists of chapters for the main categories of subjects. (See "Illustrated symbols")

1st title ①: This is the title of the chapter with its symbol in the upper right corner of each page.

2nd title ②: This title indicates the section of the chapter and only appears on the first page of each section. It is located in the upper left corner of the page.

3rd title ③: This title indicates a sub-section that is followed by step-by-step procedures accompanied by corresponding illustrations.

EXPLODED DIAGRAMS

To help identify parts and clarify procedure steps, there are exploded diagrams at the start of each removal and disassembly section.

1. An easy-to-see exploded diagram ④ is provided for removal and disassembly jobs.
2. Numbers ⑤ are given in the order of the jobs in the exploded diagram. A number that is enclosed by a circle indicates a disassembly step.
3. An explanation of jobs and notes is presented in an easy-to-read way by the use of symbol marks ⑥. The meanings of the symbol marks are given on the next page.
4. A job instruction chart ⑦ accompanies the exploded diagram, providing the order of jobs, names of parts, notes in jobs, etc.
5. For jobs requiring more information, the step-by-step format supplements ⑧ are given in addition to the exploded diagram and the job instruction chart.

②
①
⑥

CLUTCH CLUTCH COVER

CLUTCH ENG

④

⑤

⑦

Order	Job name/Part name	Qty	Remarks
	Clutch cover removal		Remove the parts in the order below. Stand the motorcycle on a level surface.
			WARNING Securely support the motorcycle so there is no danger of it falling over. Refer to "ENGINE OIL REPLACEMENT" in CHAPTER 3.
	Engine oil		Refer to "ENGINE REMOVAL".
	Muffler assembly 1,2		
	Brake pedal link		
1	Oil filter cover plate	1	
2	Oil filter cover	1	L=70 mm × 1, 85 mm × 1, 25 mm × 3
3	O-ring	1	
4	Oil filter	1	
5	Crankcase cover (right)	1	L=65 mm × 1, 55 mm × 1, 45 mm × 4, 30 mm × 4

CLUTCH ENG

③

⑧

CLUTCH REMOVAL

1. Straighten:
• Lock washer tab
2. Loosen:
• Nut (clutch boss) ①

NOTE:
Loosen the nut (clutch boss) ① while holding the clutch boss ② with the clutch holding tool ③.

Clutch holding tool:
Simp-Case

PRIMARY DRIVE GEAR REMOVAL

1. Straighten:
• Lock washer tab
2. Loosen:
• Nut (primary drive gear) ①

NOTE:
Place a copper plate ④ between the teeth of the primary drive gear ① and primary driven gear to lock them.

CLUTCH INSPECTION

1. Inspect:
• Friction plates
Wear/damage → Replace the friction plates as a set.

















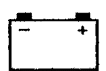





2. Measure:
• Friction plate thickness
Out of specification → Replace the friction plates as a set.
Measure at four places.

Thickness friction plates:
2.2 - 3.1 mm
Wear limit: 2.4 mm

3. Inspect:
• Clutch plate
Damage → Replace the clutch plates as a set.

4. Measure:
• Clutch plate wearpage
Out of specification → Replace the clutch plates as a set.
Use a surface plate and a feeler gauge ⑤.

Warp limit (clutch plate):
Less than 0.2 mm

① GEN INFO 	② SPEC 	
③ INSP ADJ 	④ ENG 	
⑤ COOL 	⑥ CARB 	
⑦ CHAS 	⑧ ELEC 	
⑨ TRBL SHTG ?	⑩ 	
⑪ 	⑫ 	
⑬ 	⑭ 	
⑮ 	⑯ 	⑰ 
⑱ 	⑲ 	⑳ 
㉑ 	㉒ 	㉓ 
㉔ 	㉕ New	

EB003000

ILLUSTRATED SYMBOLS

Illustrated symbols ① to ⑨ are printed on the top right of each page and indicate the subject of each chapter.

- ① General information
- ② Specifications
- ③ Periodic inspections and adjustments
- ④ Engine
- ⑤ Cooling system
- ⑥ Carburetion
- ⑦ Chassis
- ⑧ Electrical
- ⑨ Troubleshooting

Illustrated symbols ⑩ to ⑰ are used to identify the specifications appearing in the text.

- ⑩ Can be serviced with engine mounted
- ⑪ Filling fluid
- ⑫ Lubricant
- ⑬ Special tool
- ⑭ Torque
- ⑮ Wear limit, clearance
- ⑯ Engine speed
- ⑰ Ω, V, A







Illustrated symbols ⑱ to ㉓ in the exploded diagrams indicate the types of lubricants and lubrication points.

- ⑱ Apply engine oil
- ⑲ Apply gear oil
- ⑳ Apply molybdenum disulfide oil
- ㉑ Apply wheel bearing grease
- ㉒ Apply lightweight lithium-soap base grease
- ㉓ Apply molybdenum disulfide grease

Illustrated symbols ㉔ to ㉕ in the exploded diagrams indicate where to apply a locking agent ㉔ and when to install new parts ㉕.

- ㉔ Apply locking agent (LOCTITE®)
- ㉕ Replace

CHAPTER TITLES

GENERAL INFORMATION	
	GEN INFO 1
SPECIFICATIONS	
	SPEC 2
PERIODIC INSPECTION AND ADJUSTMENT	
	INSP ADJ 3
ENGINE OVERHAUL	
	ENG 4
CARBURETION	
	CARB 5
CHASSIS	
	CHAS 6
ELECTRICAL	
	ELEC 7
TROUBLESHOOTING	?
	TRBL SHTG 8









CONTENTS

CHAPTER 1. GENERAL INFORMATION

MOTORCYCLE IDENTIFICATION	1-1
VEHICLE IDENTIFICATION NUMBER	1-1
MODEL LABEL	1-1
 IMPORTANT INFORMATION	 1-2
PREPARATION FOR REMOVAL PROCEDURES	1-2
REPLACEMENT PARTS	1-2
GASKETS, OIL SEALS AND O-RINGS	1-2
LOCK WASHERS/PLATES AND COTTER PINS	1-3
BEARINGS AND OIL SEALS	1-3
CIRCLIPS	1-3
 CHECKING OF CONNECTIONS	 1-4
 SPECIAL TOOLS	 1-5

CHAPTER 2. SPECIFICATIONS

GENERAL SPECIFICATIONS	2-1
 MAINTENANCE SPECIFICATIONS	 2-4
ENGINE	2-4
CHASSIS	2-14
ELECTRICAL	2-18
 GENERAL TORQUE SPECIFICATIONS	 2-20
 LUBRICATION POINTS AND LUBRICANT TYPES	 2-21
ENGINE	2-21
CHASSIS	2-22
 LUBRICATION DIAGRAMS	 2-23
 CABLE ROUTING	 2-27

	GEN INFO	1
	SPEC	2
	INSP ADJ	3
	ENG	4
	CARB	5
	CHAS	6
	ELEC	7
	TRBL SHTG	8







CHAPTER 3. PERIODIC INSPECTIONS AND ADJUSTMENTS

INTRODUCTION	3-1
PERIODIC MAINTENANCE/LUBRICATION INTERVALS	3-1
GENERAL MAINTENANCE/LUBRICATION	3-2
FUEL TANK AND SEATS	3-4
ENGINE	3-5
VALVE CLEARANCE ADJUSTMENT	3-5
CARBURETOR SYNCHRONIZATION	3-8
IDLING SPEED ADJUSTMENT	3-10
THROTTLE CABLE ADJUSTMENT	3-11
SPARK PLUG INSPECTION	3-12
IGNITION TIMING CHECK	3-13
COMPRESSION PRESSURE MEASUREMENT	3-15
ENGINE OIL LEVEL INSPECTION	3-17
ENGINE OIL REPLACEMENT	3-18
CLUTCH ADJUSTMENT	3-20
AIR FILTER CLEANING	3-20
CARBURETOR JOINT INSPECTION	3-21
FUEL LINE INSPECTION	3-21
BREATHER HOSE INSPECTION	3-22
EXHAUST SYSTEM INSPECTION	3-22
CHASSIS	3-23
FRONT BRAKE ADJUSTMENT	3-23
REAR BRAKE ADJUSTMENT	3-24
BRAKE FLUID LEVEL INSPECTION	3-25
BRAKE PAD INSPECTION	3-26
BRAKE SHOE INSPECTION	3-26
BRAKE LIGHT SWITCH ADJUSTMENT	3-26
BRAKE HOSE INSPECTION	3-27
AIR BLEEDING (HYDRAULIC BRAKE SYSTEM)	3-27
SHIFT PEDAL ADJUSTMENT	3-28
FINAL GEAR OIL LEVEL INSPECTION	3-29
FINAL GEAR OIL REPLACEMENT	3-30
STEERING HEAD INSPECTION	3-30
FRONT FORK INSPECTION	3-32
REAR SHOCK ABSORBER ADJUSTMENT	3-33
TIRE INSPECTION	3-33
WHEEL INSPECTION	3-36
SPOKE INSPECTION AND TIGHTENING	3-36
CABLE INSPECTION AND LUBRICATION	3-36
LEVER AND PEDAL LUBRICATION	3-37
SIDESTAND LUBRICATION	3-37

ELECTRICAL	3-38
BATTERY INSPECTION	3-38
FUSE INSPECTION	3-43
HEADLIGHT BEAM ADJUSTMENT	3-45
HEADLIGHT BULB REPLACEMENT	3-45

CHAPTER 4. ENGINE

ENGINE REMOVAL	4-1
MUFFLERS, BRAKE PEDAL AND SIDE COVER	4-1
CYLINDER HEAD COVERS	4-3
SIDESTAND AND CRANKCASE COVER (LEFT)	4-5
ENGINE MOUNTING BOLTS	4-6
SHIFT PEDAL INSTALLATION	4-8
BRAKE PEDAL INSTALLATION	4-8
 CYLINDER HEADS	4-9
CYLINDER HEAD REMOVAL	4-11
CYLINDER HEAD INSPECTION	4-12
CYLINDER HEAD INSTALLATION	4-14
 ROCKER ARMS AND CAMSHAFT	4-17
ROCKER ARM AND CAMSHAFT REMOVAL	4-18
ROCKER ARM AND CAMSHAFT INSPECTION	4-18
ROCKER ARM AND CAMSHAFT INSTALLATION	4-19
 VALVES AND VALVE SPRINGS	4-21
VALVE AND VALVE SPRING REMOVAL	4-22
VALVE AND VALVE SPRING INSPECTION	4-22
VALVE AND VALVE SPRING INSTALLATION	4-26
 CYLINDERS AND PISTONS	4-28
PISTON REMOVAL	4-29
CYLINDER AND PISTON INSPECTION	4-29
PISTON RING INSPECTION	4-31
PISTON PIN INSPECTION	4-32
CYLINDER AND PISTON INSTALLATION	4-33
 CLUTCH	4-34
CRANKCASE COVER (RIGHT)	4-34
CLUTCH ASSEMBLY	4-36
CLUTCH REMOVAL	4-38
PRIMARY DRIVE GEAR REMOVAL	4-38
CLUTCH INSPECTION	4-38
PUSH ROD INSPECTION	4-40
PRIMARY DRIVE GEAR INSTALLATION	4-40
CLUTCH INSTALLATION	4-40

	GEN INFO	1
	SPEC	2
	INSP ADJ	3
	ENG	4
	CARB	5
	CHAS	6
	ELEC	7
?	TRBL SHTG	8

SHIFT SHAFT	4-42
SHIFT SHAFT INSPECTION	4-43
SHIFT SHAFT INSTALLATION	4-43
OIL PUMP	4-45
OIL PUMP INSPECTION	4-47
AC MAGNETO AND STARTER CLUTCH	4-48
STATOR COIL AND PICKUP COIL	4-48
AC MAGNETO AND STARTER CLUTCH	4-49
AC MAGNETO REMOVAL	4-50
STARTER CLUTCH INSPECTION	4-50
AC MAGNETO INSTALLATION	4-51
CRANKSHAFT AND CONNECTING RODS	4-53
CRANKCASE	4-53
CRANKSHAFT AND CONNECTING RODS	4-55
CRANKCASE SEPARATION	4-56
CRANKSHAFT REMOVAL	4-57
CRANKSHAFT INSPECTION	4-57
CRANKSHAFT INSTALLATION	4-62
CRANKCASE ASSEMBLY	4-63
TRANSMISSION	4-65
SHIFT FORK INSPECTION	4-66
SHIFT CAM INSPECTION	4-66
TRANSMISSION INSPECTION	4-66
TRANSMISSION INSTALLATION	4-68
MIDDLE GEAR	4-69
MIDDLE DRIVEN PINION GEAR	4-69
MIDDLE DRIVE PINION GEAR	4-71
MIDDLE DRIVEN PINION GEAR REMOVAL	4-72
MIDDLE DRIVE PINION GEAR REMOVAL	4-73
MIDDLE GEAR INSPECTION	4-74
MIDDLE DRIVE PINION GEAR INSTALLATION	4-74
MIDDLE DRIVEN PINION GEAR INSTALLATION	4-75
MIDDLE DRIVE GEAR SHIM SELECTION	4-78
GEAR BACKLASH ADJUSTMENT	4-79









CHAPTER 5. CARBURETION

CARBURETOR	5-1
CARBURETOR INSPECTION	5-4
CARBURETOR ASSEMBLY	5-5
FUEL LEVEL ADJUSTMENT	5-7
THROTTLE POSITION SENSOR (TPS) INSPECTION AND ADJUSTMENT	5-8

AIR INDUCTION SYSTEM (AIS)	5-10
AIR INJECTION	5-10
AIR CUT-OFF VALVE	5-10
AIR INDUCTION SYSTEM INSPECTION	5-11

CHAPTER 6. CHASSIS

FRONT WHEEL AND BRAKE DISC	6-1
FRONT WHEEL DISASSEMBLY	6-3
FRONT WHEEL INSPECTION	6-3
BRAKE DISK INSPECTION	6-4
FRONT WHEEL ASSEMBLY	6-5
FRONT WHEEL INSTALLATION	6-5
FRONT WHEEL STATIC BALANCE ADJUSTMENT	6-6
 FRONT BRAKE	 6-8
FRONT BRAKE PADS	6-8
BRAKE PAD REPLACEMENT	6-9
MASTER CYLINDER	6-11
MASTER CYLINDER INSPECTION	6-13
MASTER CYLINDER ASSEMBLY	6-13
MASTER CYLINDER INSTALLATION	6-14
FRONT BRAKE CALIPER	6-16
CALIPER DISASSEMBLY	6-18
CALIPER INSPECTION	6-18
CALIPER ASSEMBLY	6-19
CALIPER INSTALLATION	6-19
 REAR WHEEL AND REAR BRAKE	 6-21
MUFFLER AND REAR BRAKE ROD	6-21
REAR WHEEL	6-22
REAR WHEEL REMOVAL	6-25
REAR WHEEL DISASSEMBLY	6-25
REAR WHEEL INSPECTION	6-25
REAR BRAKE INSPECTION	6-26
REAR WHEEL ASSEMBLY	6-27
REAR BRAKE ASSEMBLY	6-28
REAR WHEEL INSTALLATION	6-28
REAR WHEEL STATIC BALANCE ADJUSTMENT	6-29
 FRONT FORK	 6-30
FRONT FORK DISASSEMBLY	6-34
FRONT FORK INSPECTION	6-35
FRONT FORK ASSEMBLY	6-35
FRONT FORK INSTALLATION	6-38
 HANDLEBAR	 6-40

	GEN INFO	1
	SPEC	2
	INSP ADJ	3
	ENG	4
	CARB	5
	CHAS	6
	ELEC	7
	TRBL SHTG	8

HANDLEBAR INSPECTION	6-42
HANDLEBAR INSTALLATION	6-42
STEERING HEAD	6-45
STEERING HEAD REMOVAL	6-47
STEERING HEAD INSPECTION	6-47
STEERING HEAD INSTALLATION	6-47
REAR SHOCK ABSORBER AND SWINGARM	6-48
HANDLING NOTES	6-50
NOTES ON DISPOSAL	6-50
REAR SHOCK ABSORBER INSPECTION	6-50
SWINGARM INSTALLATION	6-51
REAR SHOCK ABSORBER INSTALLATION	6-51
SWINGARM INSPECTION	6-52
SHAFT DRIVE	6-53
TROUBLESHOOTING	6-53
FINAL GEAR BACKLASH MEASUREMENT	6-57
FINAL GEAR BACKLASH ADJUSTMENT	6-58
DRIVE SHAFT	6-59
FINAL GEAR	6-60
FINAL DRIVE GEAR DISASSEMBLY	6-61
FINAL DRIVE ROLLER BEARING REMOVAL AND REASSEMBLY	6-61
FINAL DRIVE/RING GEAR POSITIONING	6-63
DRIVE SHAFT INSPECTION	6-67
FINAL GEAR CASE INSTALLATION	6-67









CHAPTER 7. ELECTRICAL

ELECTRICAL COMPONENTS	7-1
SWITCH INSPECTION	7-2
SWITCH INSPECTION	7-2
INSPECTING A SWITCH SHOWN IN THE MANUAL	7-2
SWITCH CONTINUITY INSPECTION	7-3
IGNITION SYSTEM	7-5
CIRCUIT DIAGRAM	7-5
TROUBLESHOOTING	7-6
ELECTRIC STARTING SYSTEM	7-11
CIRCUIT DIAGRAM	7-11
STARTING CIRCUIT OPERATION	7-12
TROUBLESHOOTING	7-13

STARTER MOTOR	7-17
STARTER MOTOR INSPECTION	7-18
STARTER MOTOR ASSEMBLY	7-19
CHARGING SYSTEM	7-21
CIRCUIT DIAGRAM	7-21
TROUBLESHOOTING	7-22
LIGHTING SYSTEM	7-24
CIRCUIT DIAGRAM	7-24
TROUBLESHOOTING	7-25
LIGHTING SYSTEM CHECK	7-27
SIGNAL SYSTEM	7-30
CIRCUIT DIAGRAM	7-30
TROUBLESHOOTING	7-32
SIGNAL SYSTEM CHECK	7-34
FUEL PUMP SYSTEM	7-38
CIRCUIT DIAGRAM	7-38
FUEL PUMP CIRCUIT OPERATION	7-39
TROUBLESHOOTING	7-40
FUEL PUMP TEST	7-43
CARBURETOR HEATER SYSTEM	7-44
CIRCUIT DIAGRAM	7-44
TROUBLESHOOTING	7-45
SELF-DIAGNOSIS	7-49
TROUBLESHOOTING	7-50

CHAPTER 8. TROUBLESHOOTING

STARTING FAILURE/HARD STARTING	8-1
FUEL SYSTEM	8-1
ELECTRICAL SYSTEM	8-1
COMPRESSION SYSTEM	8-2
POOR IDLE SPEED PERFORMANCE	8-2
POOR IDLE SPEED PERFORMANCE	8-2
POOR MEDIUM-AND HIGH-SPEED PERFORMANCE	8-2
POOR MEDIUM-AND HIGH-SPEED PERFORMANCE	8-2

	GEN INFO	1
	SPEC	2
	INSP ADJ	3
	ENG	4
	CARB	5
	CHAS	6
	ELEC	7
	TRBL SHTG	8

FAULTY GEAR SHIFTING	8-3
HARD SHIFTING	8-3
SHIFT PEDAL DOES NOT MOVE	8-3
JUMPS-OUT-OF GEAR	8-3
CLUTCH SLIPPING/Dragging	8-3
CLUTCH SLIPPING	8-3
CLUTCH DRAGGING	8-3
OVERHEATING	8-4
OVERHEATING	8-4
FAULTY BRAKE	8-4
POOR BRAKING EFFECT	8-4
FRONT FORK OIL LEAKAGE AND FRONT FORK MALFUNCTION	8-4
MALFUNCTION	8-4
OIL LEAKAGE	8-4
UNSTABLE HANDLING	8-5
UNSTABLE HANDLING	8-5
FAULTY LIGHTING AND SIGNAL SYSTEMS	8-5
HEADLIGHT DOES NOT LIGHT	8-5
BULB BURNT OUT	8-5
FLASHER DOES NOT LIGHT	8-5
FLASHER BLINKS SLOWLY	8-5
FLASHER REMAINS LIT	8-5
FLASHER BLINKS QUICKLY	8-5
HORN DOES NOT SOUND	8-5

XVS650AK(C) WIRING DIAGRAM

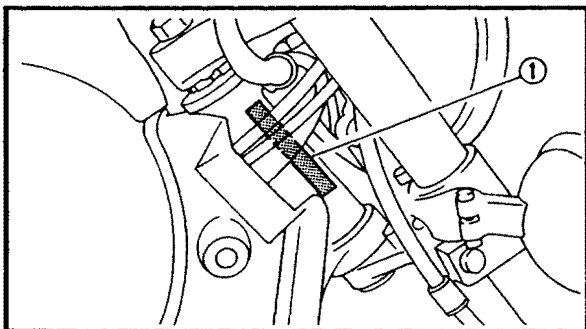

EB100000

**GENERAL INFORMATION
MOTORCYCLE IDENTIFICATION**

EB100010

VEHICLE IDENTIFICATION NUMBER

The vehicle identification number ① is stamped into the right side of the steering head.

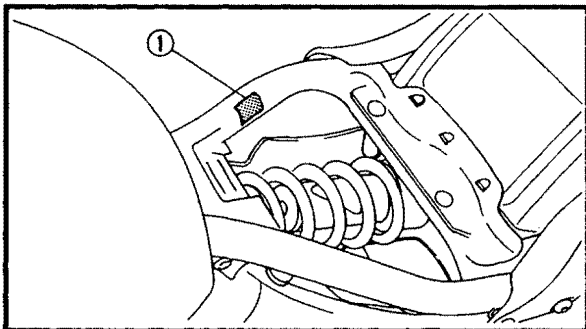

MODEL LABEL

The model label ① is affixed to the frame. This information will be needed to order spare parts.

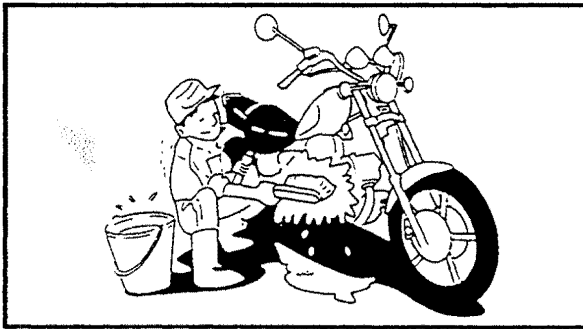

EB101000

**IMPORTANT INFORMATION
PREPARATION FOR REMOVAL
PROCEDURES**

1. Remove all dirt, mud, dust and foreign material before removal and disassembly.

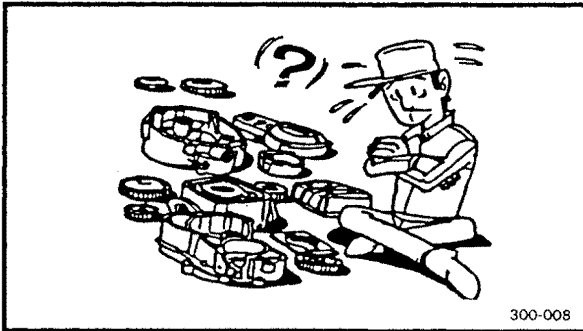

300-008

2. Use proper tools and cleaning equipment. Refer to the "SPECIAL TOOLS" section.

3. When disassembling the machine, always keep mated parts together. This includes gears, cylinders, pistons and other parts that have been "mated" through normal wear. Mated parts must always be reused or replaced as an assembly.

4. During machine disassembly, clean all parts and place them in trays in the order of disassembly. This will speed up assembly and allow for the correct installation of all parts.

5. Keep all parts away from any source of fire.

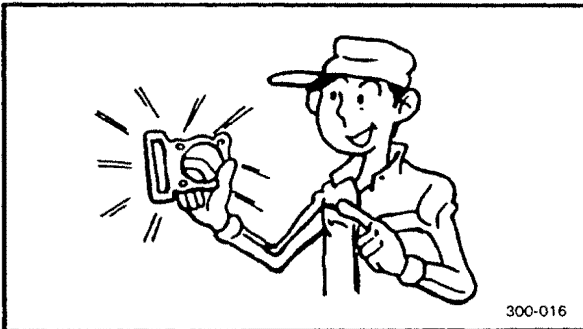

300-016

EB101010

REPLACEMENT PARTS

1. Use only genuine Yamaha parts for all replacements. Use oil and grease recommended by Yamaha for all lubrication jobs. Other brands may be similar in function and appearance, but inferior in quality.

EB101020

GASKETS, OIL SEALS AND O-RINGS

1. Replace all gaskets, seals and O-rings when overhauling the engine. All gasket surfaces, oil seal lips and O-rings must be cleaned.

2. Properly oil all mating parts and bearings during reassembly. Apply grease to the oil seal lips.

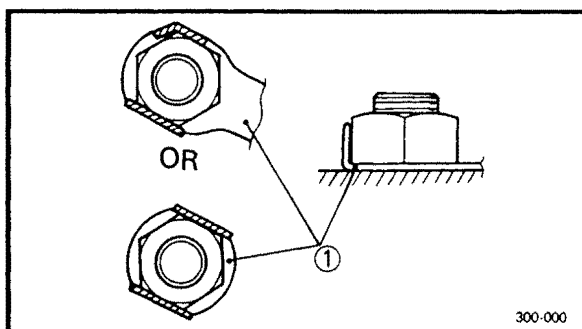

EB101030
LOCK WASHERS/PLATES AND COTTER PINS

1. Replace all lock washers/plates ① and cotter pins after removal. Bend lock tabs along the bolt or nut flats after the bolt or nut has been tightened to specification.

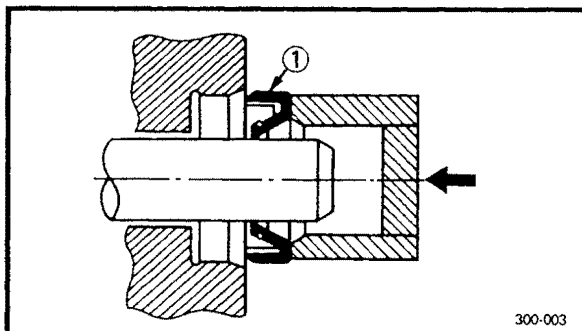

EB101040
BEARINGS AND OIL SEALS

1. Install bearings and oil seals so that the manufacturer's marks or numbers are visible. When installing oil seals, apply a light coating of lightweight lithium base grease to the seal lips. Oil bearings liberally when installing, if appropriate.

① Oil seal

CAUTION:

Do not use compressed air to spin the bearings dry. This will damage the bearing surfaces.

① Bearing

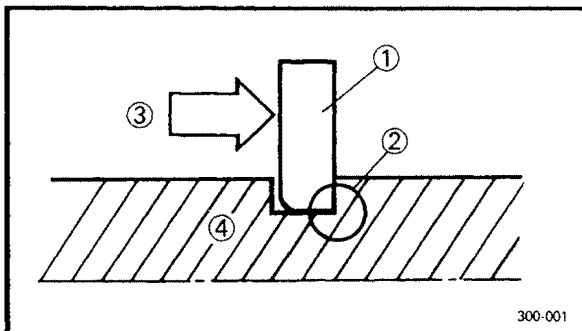
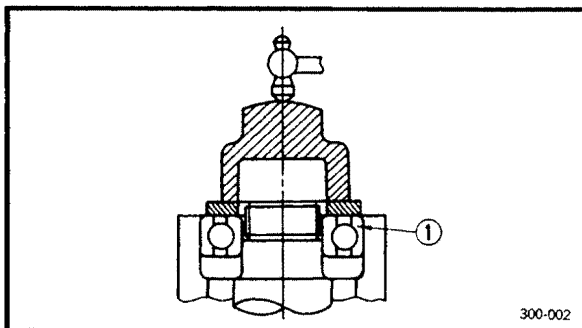

EB101050
CIRCLIPS

1. Check all circlips carefully before reassembly. Always replace piston pin clips after one use. Replace distorted circlips. When installing a circlip ①, make sure that the sharp-edged corner ② is positioned opposite the thrust ③ it receives. See sectional view.

④ Shaft

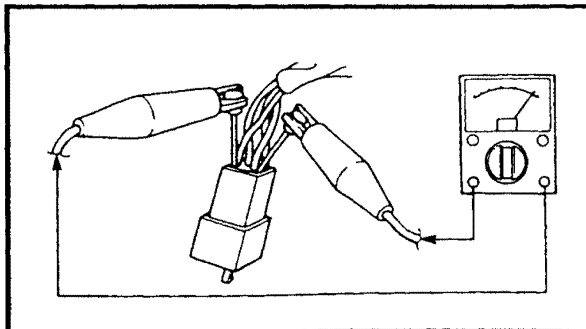
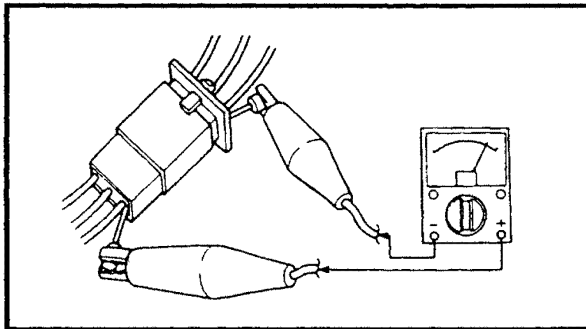
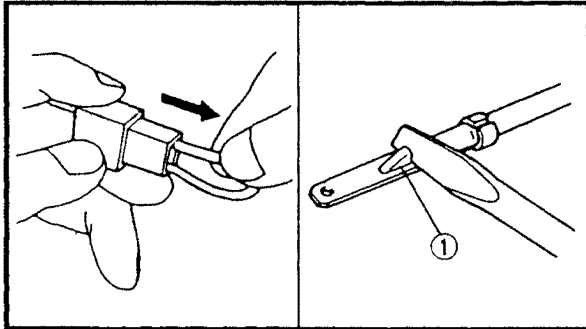
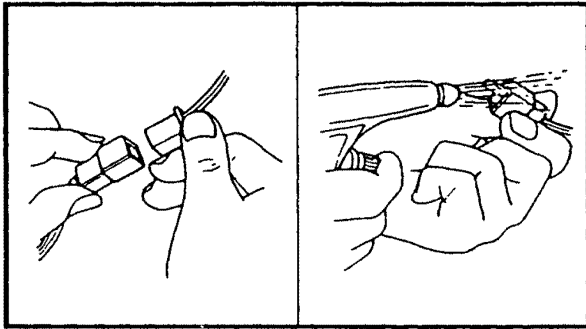

EB801000

CHECKING OF CONNECTIONS

Check the connectors for stains, rust, moisture, etc.

1.Disconnect:

- Connector

2.Check:

- Connector

Moisture → Dry each terminal with an air blower.

Stains/rust → Connect and disconnect the terminals several times.

3.Check:

- Connector leads

Looseness → Bend up the pin ① and connect the terminals.

4.Connect:

- Connector terminals

NOTE:

The two terminals "click" together.

5.Check:

- Continuity (using a pocket tester)

NOTE:

- If there is no continuity, clean the terminals.

- When checking the wire harness be sure to perform steps 1 to 3.

- As a quick remedy, use a contact revitalizer available at most part stores.



- Check the connector with a pocket tester as shown.

EB102001

SPECIAL TOOLS

The following special tools are necessary for complete and accurate tune-up and assembly. Use only the appropriate special tools; this will help prevent damage caused by the use of inappropriate tools or improvised techniques. Special tools may differ by shape and part number from country to country. In such a case, two types are provided. When placing an order, refer to the list provided below to avoid any mistakes.

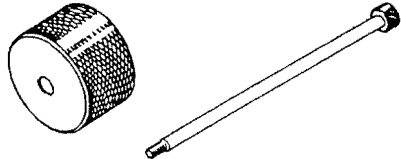
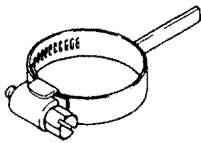
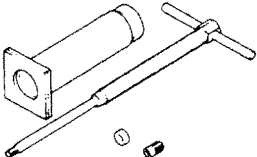
P/N.YM-, YU-
For US, CDN
YS-, YK- ACC-
P/N.90890-
Except for US, CDN

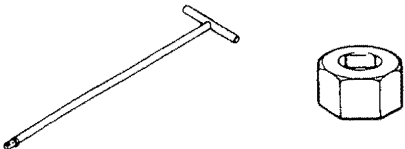
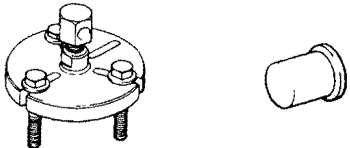
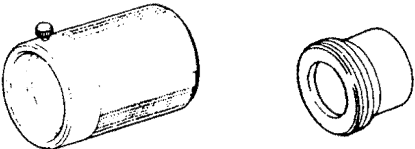
Tool No.	Tool name / How to use	Illustration
Weight YU-1083-3 90890-01084 Bolt YU-1083-2 90890-01085	Slide hammer bolt / weight These tools are used to remove the rocker arm shaft.	
YM-01231 90890-01231	Final gear backlash band This tool is needed when measuring final gear backlash.	
YU-01304 90890-01304	Piston pin puller This tool is used to remove the piston pin.	
YM-01312-A 90890-01312	Fuel level gauge This gauge is used to measure the fuel level in the float chamber.	
T-handle YM-01326 90890-01326 Holder YM-01388 90890-01388	T-handle / damper rod holder These tools are needed to loosen and tighten the damper rod holding bolt.	
Puller YU-33270 90890-01362 Adapter YM-33282 90890-04089	Flywheel puller / adapter These tools are needed to remove the rotor.	
Weight YM-33963 90890-01367 Adapter YM-8020 90890-01381	Fork seal driver weight / adapter These tools are needed when installing the slide metal, oil seal and dust seal into the fork.	

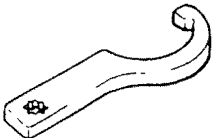
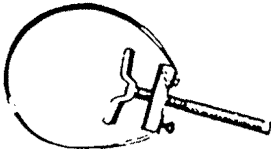
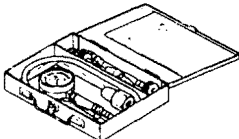
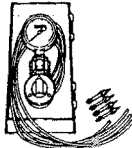
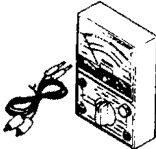
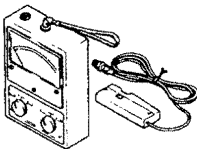
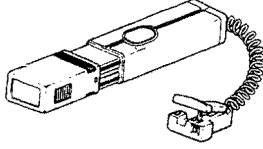
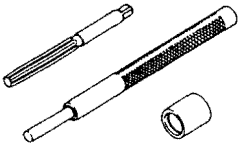
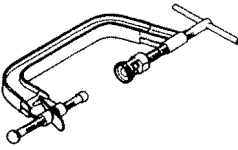
Tool No.	Tool name / How to use	Illustration
YU-33975 90890-01403	Ring nut wrench This tool is needed to loosen and tighten the steering stem ring nut.	
YU-01880 90890-01701	Sheave holder This tool is needed to hold the rotor when removing or installing the rotor bolt.	
YU-33223 90890-03081	Compression gauge set These tools are needed to measure engine compression.	
YU-08030-A 90890-03094	Vacuum gauge This gauge is needed for carburetor synchronization.	
YU-03112 90890-03112	Pocket tester This instrument is needed for checking the electrical system.	
YU-08036-A 90890-03113	Engine tachometer This tool is needed for observing engine rpm.	
YU-33277-A 90890-03141	Timing light This tool is necessary for checking ignition timing.	
Remover YM-01225-A Remover YM-01227 Installer YM-04017 90890-04018	Valve guide remover & installer This tool is needed to remove and install the valve guide.	
Compressor YM-04019 90890-04019	Valve spring compressor This tool is needed to remove and install the valve assemblies.	

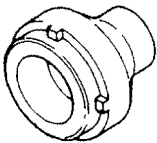
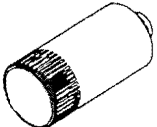
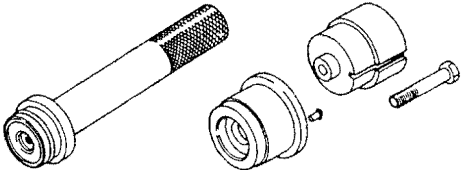
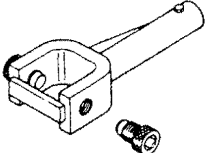
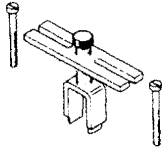
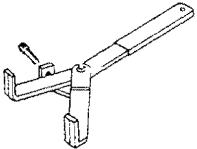
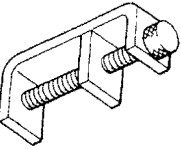
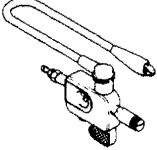
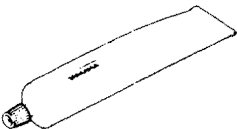
Tool No.	Tool name / How to use	Illustration
<p>YM-04050 90890-04050</p>	<p>Bearing retainer wrench</p> <p>This tool is needed when removing or installing the final drive shaft bearing.</p>	
<p>YM-04057 90890-04057</p>	<p>Bearing retainer wrench</p> <p>This tool is needed when removing or installing the middle driven shaft bearing.</p>	
<p>Driver YM-04058 90890-04058 Installer / remover YM-28898 90890-04074</p>	<p>Middle driven shaft bearing driver Plain bearing installer / remover</p> <p>These tools are needed when removing or installing the main journal bearing.</p>	
<p>YM-04062 90890-04062</p>	<p>Universal joint holder</p> <p>This tool is needed when removing or installing the driven pinion gear nut.</p>	
<p>YM-33222 90890-04080</p>	<p>Middle gear backlash tool</p> <p>This tool is needed for the gear backlash adjustment.</p>	
<p>YM-91042 90890-04086</p>	<p>Clutch holding tool</p> <p>This tool is needed to hold the clutch when removing or installing the clutch boss nut.</p>	
<p>YM-33286 90890-04090</p>	<p>Damper spring compressor</p> <p>This tool is needed when removing or installing the damper spring.</p>	
<p>YM-34487 90890-06754</p>	<p>Dynamic spark tester Ignition checker</p> <p>This instrument is necessary for checking the ignition system components.</p>	
<p>ACC-1100-15-01 90890-85505</p>	<p>Yamaha bond No.1215</p> <p>This sealant (bond) is used on crank-case mating surfaces, etc.</p>	



SPECIFICATIONS

GENERAL SPECIFICATIONS

Item	Standard
Model code:	XVS650: 5BN1 (For USA) 5BN2 (For California) 5BN3 (For Canada)
Dimensions:	
Overall length	2,450 mm (96.5 in)
Overall width	930 mm (36.6 in)
Overall height	1,135 mm (44.7 in)
Seat height	710 mm (28.0 in)
Wheelbase	1,625 mm (64.0 in)
Minimum ground clearance	145 mm (57.1 in)
Minimum turning radius	3,400 mm (133.9 in)
Basic weight:	
With oil and a full fuel tank	243 kg (535.7 lb)
Engine:	
Engine type	Air cooled 4-stroke, SOHC
Cylinder arrangement	V-type 2-cylinder
Displacement	0.649 cm ³
Bore × stroke	81 × 63 mm (3.19 × 2.48 in)
Compression ratio	9 : 1
Compression pressure (STD)	1,000 kPa (10 kg/cm ² , 14.1 psi) at 300 r/min
Starting system	Electric starter
Lubrication system:	Wet sump
Oil type or grade:	
Engine oil	
	Yamalube 4 (20W40) or SAE20W40 type SE motor oil (40°F/5°C or above)
	Yamalube 4 (10W30) or SAE10W30 type SE motor oil (60°F/15°C or below)
Final gear oil:	SAE80API "GL-4" Hypoid Gear Oil
Oil quantity:	
Engine oil	
Periodic oil change	2.6 L (2.3 Imp qt, 2.75 US qt)
With oil filter replacement	2.8 L (2.5 Imp qt, 3.0 US qt)
Total amount	3.2 L (2.8 Imp qt, 3.4 US qt)
Final gear case oil	
Total amount	0.19 L (0.17 Imp qt, 0.2 US qt)
Air filter:	Dry type element
Fuel:	
Type	Regular unleaded gasoline
Fuel tank capacity	16 L (14.1 Imp qt, 16.9 US qt)
Fuel reserve amount	3.0 L (2.6 Imp qt, 3.2 US qt)

GENERAL SPECIFICATIONS

SPEC



Item	Standard
Carburetor: Type / quantity Manufacturer	BDS28 / 2 MIKUNI
Spark plug: Type Manufacturer Spark plug gap	DPR7EA-9 / X22EPR-U9 NGK / DENSO 0.8 ~ 0.9 mm (0.031 ~ 0.035 in)
Clutch type:	Wet, multiple-disc
Transmission: Primary reduction system Primary reduction ratio Secondary reduction system Secondary reduction ratio Transmission type Operation Gear ratio	Spur gear 68/38 (1.789) Shaft drive 19/18 × 32/11(3.071) Constant mesh 5-speed Left foot operation 1st 38/14 (2.714) 2nd 38/20 (1.900) 3rd 35/24 (1.458) 4th 28/24 (1.167) 5th 29/30 (0.967)
Chassis: Frame type Caster angle Trail	Double cradle 35° 145 mm (5.71 in)
Tire: Type Size Manufacturer Type	With tube 130/90-16 67S 170/80-15M/C 77S BRIDGESTONE / DUNLOP BRIDGESTONE / DUNLOP G703 / D404F G702 / D404
Maximum load-except motorcycle:	200 kg (441 lb)
Tire pressure (cold tire): 0 ~ 90 kg (0 ~ 198 lb) load * 90 kg (198 lb) ~ Maximum load *	front 225 kPa (2.25 kg/cm ² , 32.6 psi) rear 225 kPa (2.25 kg/cm ² , 32.6 psi) front 225 kPa (2.25 kg/cm ² , 32.6 psi) rear 250 kPa (2.50 kg/cm ² , 36.3 psi) * Load is the total weight of the cargo, rider, passenger and accessories.
Brake: Front brake Rear brake	type operation Single disc brake Right hand operation type operation Drum brake Right foot operation

GENERAL SPECIFICATIONS

SPEC



Item	Standard
Suspension: Front suspension Rear suspension	Telescopic fork Swingarm (Monocross)
Shock absorber: Front shock absorber Rear shock absorber	Coil spring / Oil damper Coil spring / Gas-oil damper
Wheel travel: Front wheel travel Rear wheel travel	140 mm (5.5 in) 98 mm (3.9 in)
Electrical: Ignition system Generator system Battery type Battery capacity	T.C.I. (digital) A.C. magneto GT12B-4 12 V 10 AH
Headlight type:	Quartz bulb (halogen)
Bulb wattage × quantity: Headlight Tail / brake light Turn signal Licence light Meter light Neutral indicator light High beam indicator light Turn indicator light	12 V 60 W / 55 W 12 V 8 W / 27 W 12 V 27 W × 4 12 V 5 W × 1 12 V 1.7 W × 1 12 V 1.7 W × 1 12 V 1.7 W × 1 12 V 1.7 W × 1

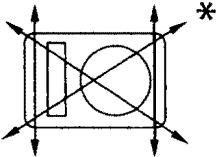
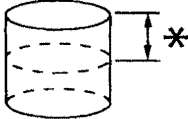
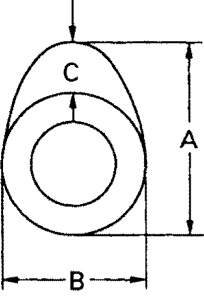
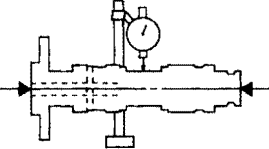

MAINTENANCE SPECIFICATIONS
ENGINE

Item	Standard	Limit
Cylinder head: Warp limit 	----	0.03 mm (0.0012 in)
Cylinder: Bore size Measuring point * 	80.945 ~ 80.995 mm (3.1868 ~ 3.1888 in) 40 mm (1.57 in)	81.1 mm (3.1929 in) ----
Camshaft: Drive method Cam cap inside diameter Camshaft outside diameter Shaft-to-cap clearance Cam dimensions  Intake "A" "B" "C" Exhaust "A" "B" "C" Camshaft runout limit 	Chain drive (left & right) 28.000 ~ 28.021 mm (1.1024 ~ 1.1032 in) 27.96 ~ 27.98 mm (1.1008 ~ 1.1016 in) 0.020 ~ 0.061 mm (0.0008 ~ 0.0024 in) 39.733 mm (1.5643 in) 32.217 mm (1.2683 in) 7.733 mm (0.3044 in) 39.772 mm (1.5658 in) 32.302 mm (1.2717 in) 7.772 mm (0.306 in) ----	---- ---- ---- ---- 39.63 mm (1.5602 in) 32.12 mm (1.2647 in) ---- 39.67 mm (1.5619 in) 32.20 mm (1.2677 in) ---- 0.03 mm (0.0012 in)

MAINTENANCE SPECIFICATIONS

SPEC

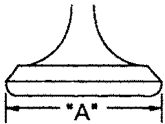
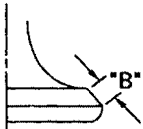
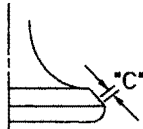
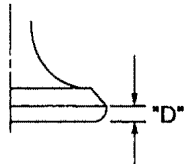

Item	Standard	Limit	
Timing chain:			
Timing chain type / No. of links	SILENT CHAIN / 118	----	
Timing chain adjustment method	Automatic	----	
Rocker arm / rocker arm shaft:			
Bearing inside diameter	14.000 mm ~ 14.018 mm (0.5512 ~ 0.5519 in)	----	
Shaft outside diameter	13.980 mm ~ 13.991 mm (0.5504 ~ 0.5508 in)	----	
Arm-to-shaft clearance	0.009 mm ~ 0.038 mm (0.0004 ~ 0.0015 in)	----	
Valve, valve seat, valve guide:			
Valve clearance (cold)	IN 0.07 ~ 0.12 mm (0.0028 ~ 0.0047 in)	----	
	EX 0.12 ~ 0.17 mm (0.0047 ~ 0.0067 in)	----	
Valve dimensions:			
			
Head Dia	Face Width	Seat Width	Margin Thickness
"A" head diameter	IN 36.9 ~ 37.1 mm (1.4528 ~ 1.4606 in)		----
	EX 31.9 ~ 32.1 mm (1.2559 ~ 1.2638 in)		----
"B" face width	IN 2.3 mm (0.09 in)		----
	EX 2.3 mm (0.09 in)		----
"C" seat width	IN 1.0 ~ 1.2 mm (0.039 ~ 0.047 in)		1.8 mm (0.07 in)
	EX 1.0 ~ 1.2 mm (0.039 ~ 0.047 in)		1.8 mm (0.07 in)
"D" margin thickness	IN 1.0 ~ 1.4 mm (0.039 ~ 0.055 in)		0.8 mm (0.03 in)
	EX 1.0 ~ 1.4 mm (0.039 ~ 0.055 in)		0.8 mm (0.03 in)
Stem outside diameter	IN 6.975 ~ 6.990 mm (0.2746 ~ 0.2752 in)		6.955 mm (0.2738 in)
	EX 6.960 ~ 6.975 mm (0.2740 ~ 0.2746 in)		6.935 mm (0.2730 in)
Guide inside diameter	IN 7.000 ~ 7.012 mm (0.2756 ~ 0.2761 in)		7.042 mm (0.2772 in)
	EX 7.000 ~ 7.012 mm (0.2756 ~ 0.2761 in)		7.042 mm (0.2772 in)
Stem-to-guide clearance	IN 0.010 ~ 0.037 mm (0.0004 ~ 0.0015 in)		0.08 mm (0.03 in)
	EX 0.025 ~ 0.052 mm (0.001 ~ 0.002 in)		0.10 mm (0.004 in)



MAINTENANCE SPECIFICATIONS

SPEC

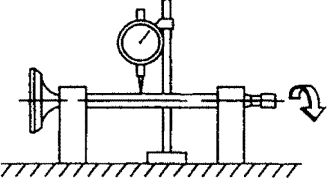
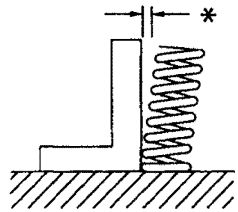
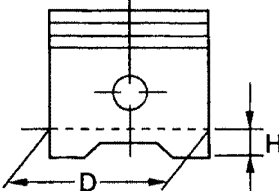

Item		Standard	Limit
Stem runout limit		----	0.03 mm (0.001 in)
 Valve seat width	IN	1.0 ~ 1.2 mm (0.039 ~ 0.047 in)	1.8 mm (0.07 in)
	EX	1.0 ~ 1.2 mm (0.039 ~ 0.047 in)	1.8 mm (0.07 in)
Valve spring:			
Free length	IN	43.2 mm (1.7 in)	42.0 mm (1.65 in)
	EX	43.2 mm (1.7 in)	42.0 mm (1.65 in)
Set length (valve closed)	IN	37.1 mm (1.46 in)	----
	EX	37.1 mm (1.46 in)	----
Compressed pressure (installed)	IN	21.8 ~ 25.6 kg (48.06 ~ 56.44 lb)	----
	EX	21.8 ~ 25.6 kg (48.06 ~ 56.44 lb)	----
Tilt limit *	IN	----	2.5°/1.9 mm (0.075 in)
	EX	----	2.5°/1.9 mm (0.075 in)
 Direction of winding (top view)	IN	Counter clockwise	----
	EX	Counter clockwise	----
Piston:			
Piston to cylinder clearance		0.035 ~ 0.055 mm (0.0014 ~ 0.0022 in)	0.15 mm (0.0059 in)
Piston size "D"		80.90 ~ 80.95 mm (3.185 ~ 3.187 in)	----
 Measuring point "H" Oversize 2nd Oversize 4th Piston off-set		6 mm (0.24 in)	----
		81.5 mm (32.1 in)	----
		82 mm (32.28 in)	----
		0 mm (0 in)	----

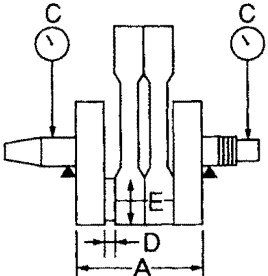

Item	Standard	Limit
Piston pin bore inside diameter Piston pin outside diameter	20.004 ~ 20.015 mm (0.7876 ~ 0.7880 in) 19.995 ~ 20.000 mm (0.7872 ~ 0.7874 in)	---- ----
Piston rings: Top ring:  Type Dimensions (B × T) End gap (installed) Side clearance (installed) 2nd ring:  Type Dimensions (B × T) End gap (installed) Side clearance Oil ring:  Dimensions (B × T) End gap (installed)	Plain 1.2 × 3.2 mm (0.047 × 0.126 in) 0.15 ~ 0.30 mm (0.006 ~ 0.012 in) 0.03 ~ 0.07 mm (0.012 ~ 0.003 in) Taper 1.5 × 3.6 mm (0.059 ~ 0.142 in) 0.30 ~ 0.45 mm (0.012 ~ 0.018 in) 0.02 ~ 0.06 mm (0.0008 ~ 0.0024 in) 2.5 × 3.1 mm (0.098 × 0.122 in) 0.2 ~ 0.7 mm (0.008 × 0.028 in)	---- ---- 0.55 mm (0.022 in) 0.12 mm (0.005 in) ---- ---- 0.8 mm (0.031 in) 0.12 mm (0.005 in) ---- ----
Connecting rod: Oil clearance Color code (corresponding size)	0.026 ~ 0.050 mm (0.001 ~ 0.002 in) ① Blue ② Black ③ Brown ④ Green	---- ----
Crankshaft:  Crank width "A" Runout limit "C" Big end side clearance "D" Big end radial clearance "E" Journal oil clearance	93.95 ~ 94.00 mm (36.988 ~ 37.007 in) ---- 0.270 ~ 0.424 mm (0.0106 ~ 0.0167 in) 0.026 ~ 0.050 mm (0.001 ~ 0.002 in) 0.020 ~ 0.052 mm (0.0008 ~ 0.002 in)	---- 0.02 mm (0.0008 in) ---- ---- ----

MAINTENANCE SPECIFICATIONS

SPEC



Item	Standard	Limit
Clutch:		
Friction plate thickness	2.9 ~ 3.1 mm (0.114 ~ 0.122 in)	2.6 mm (0.102 in)
Quantity	7	----
Clutch plate thickness	1.5 ~ 1.7 mm (0.059 ~ 0.067 in)	0.2 mm (0.008 in)
Quantity	6	----
Clutch spring free length	39.5 mm (1.555 in)	38.5 mm (1.516 in)
Quantity	5	----
Clutch housing thrust clearance	0.10 ~ 0.37 mm (0.004 ~ 0.015 in)	----
Clutch housing radial clearance	0.015 ~ 0.043 mm (0.0006 ~ 0.0017 in)	----
Clutch release method	Inner push, cam push	----
Push rod bending limit	----	0.5 mm (0.02 in)
Transmission:		
Main axle deflection limit	----	0.06 mm (0.002 in)
Drive axle deflection limit	----	0.06 mm (0.002 in)
Shifter:		
Shifter type	Guide bar	----
Carburetor:		
I. D. mark	5BN 00 : 5BN1 5BN3 5BN 10 : 5BN2	----
Main jet (M.J)	#90	----
Main air jet (M.A.J)	#50	----
Jet needle (J.N)	4CT3-1	----
Needle jet (N.J)	O-4	----
Pilot air jet (P.A.J.1)	#100	----
Pilot outlet (P.O)	0.85	----
Pilot jet (P.J)	#20	----
Bypass 1 (B.P.1)	0.8	----
Bypass 2 (B.P.2)	0.8	----
Bypass 3 (B.P.3)	0.8	----
Pilot screw (P.S)	2-1/2	----
Valve seat size (V.S)	1.0	----
Starter jet (G.S.1)	#17.5	----
Starter jet (G.S.2)	0.9	----
Throttle valve size (Th.V)	#140	----
Fuel level (F.L)	7.5 ~ 8.5 mm (0.3 ~ 0.33 in)	----
Engine idle speed	1,150 ~ 1,250 r/min	----
Intake vacuum	29.0 kPa (220 mmHg, 8.7 inHg)	----
Engine oil temperature	80 ~ 90 °C	----
Fuel pump:		
Type	Electrical type	----
Model / manufacturer	UC-Z6M / MITSUBISHI	----
Consumption amperage <max>	0.8 A	----
Output pressure	12 kPa (0.12 kg/cm ² , 1.7 psi)	----

MAINTENANCE SPECIFICATIONS

SPEC

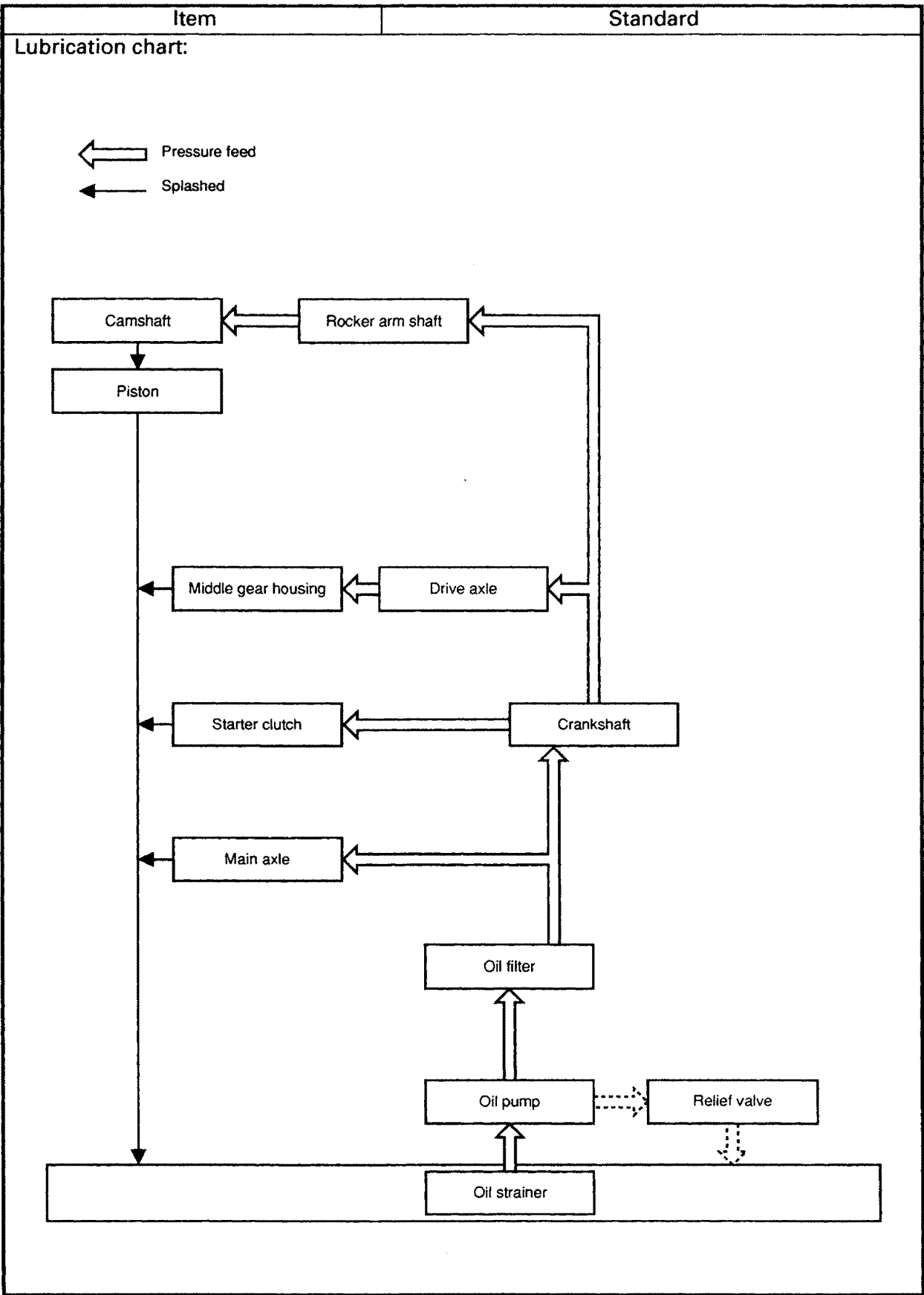

Item	Standard	Limit
Lubrication system:		
Oil filter type	Paper type	----
Oil pump type	Trochoid type	----
Tip clearance "A" or "B"	0.12 mm (0.005 in)	0.2 mm (0.008 in)
Side clearance	0.03 ~ 0.08 mm (0.001 ~ 0.003 in)	0.15 mm (0.006 in)
Relief valve operating pressure	440 ~ 540 kPa (4.5 ~ 5.5 kg/cm ² , 63.8 ~ 78.3 psi)	----
Oil pressure (hot)	10 kPa (0.1 kg/cm ² , 1.5 psi) at 1,200 r/min	----
Pressure check location	H/C UNION BOLT	----
Shaft drive:		
Middle gear backlash	0.05 ~ 0.10 mm (0.002 ~ 0.004 in)	----
Final gear backlash	0.1 ~ 0.2 mm (0.004 ~ 0.008 in)	----





Cylinder head tightening sequence:

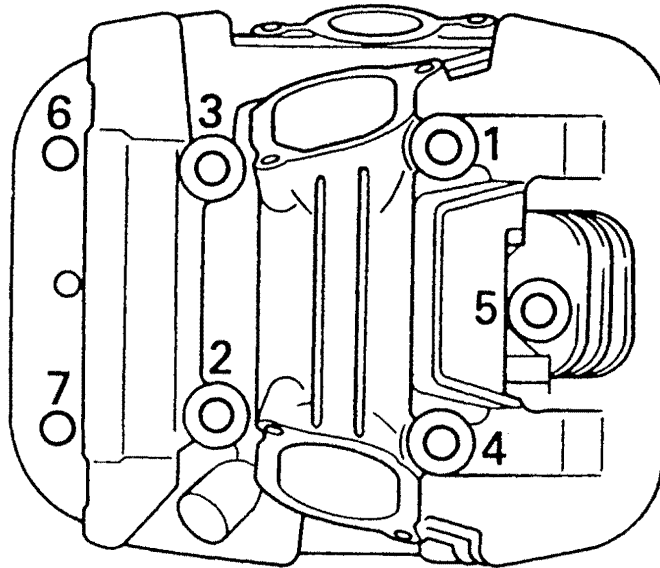

Crankcase tightening sequence:

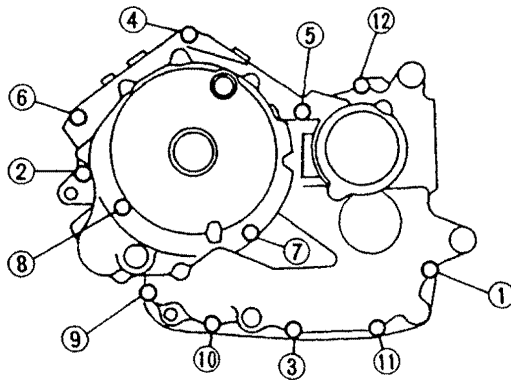

Left crankcase

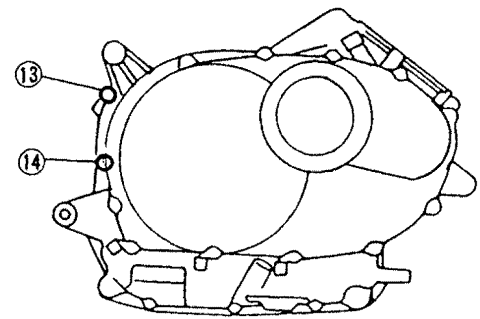





Right crankcase

MAINTENANCE SPECIFICATIONS







Tightening torques

Part to be tightened	Part name	Thread size	Q'ty	Tightening torque			Remarks
				Nm	m.kg	ft.lb	
Cylinder head	Nut	M10	8	35	3.5	25.3	
Cylinder head	Nut	M8	2	20	2.0	14.0	
Cylinder head	Bolt	M8	4	20	2.0	14.0	
Cylinder head cover bracket	Nut	M10	8	35	3.5	25.3	
Cylinder head (exhaust pipe)	Stud bolt	M8	4	15	1.5	10.8	
Camshaft sprocket cover	Bolt	M6	4	10	1.0	7.2	
Tappet cover	Bolt	M6	8	10	1.0	7.2	
Rocker arm shaft (oil passage)	Bolt	M16	4	38	3.8	27	
Bearing retainer (camshaft)	Bolt	M8	4	20	2.0	14.0	Use lock washer
Spark plug	—	M12	2	18	1.8	13.0	
Cylinder	Bolt	M6	2	10	1.0	7.2	
Lower cylinder head cover	Bolt	M6	6	10	1.0	7.2	
Upper cylinder head cover	Screw	M6	8	5	0.5	3.6	
Connecting rod	Nut	M8	4	36	3.6	26.0	
Rotor	Bolt	M10	1	80	8.0	57.9	
Valve adjusting locknut	Nut	M6	4	14	1.4	10.1	
Camshaft sprocket	Bolt	M10	2	55	5.5	39.8	
Timing chain tensioner	Bolt	M6	4	12	1.2	8.7	
Timing chain guide	Bolt	M6	4	10	1.0	7.2	
Oil pump	Bolt	M6	3	7	0.7	5.1	
Oil strainer cover	Bolt	M6	3	10	1.0	7.2	
Oil filter cover	Bolt	M6	5	10	1.0	7.2	
Carburetor joint	Bolt	M6	4	12	1.2	8.7	
Air filter case stay	Bolt	M6	2	12	1.2	8.7	
Air filter case assembly	Bolt	M6	2	12	1.2	8.7	
Exhaust pipe joint (rear) and cylinder head	Nut	M8	2	20	2.0	14.5	
Exhaust pipe joint (rear) and muffler assembly (rear)	Bolt	M8	2	20	2.0	14.5	
Exhaust pipe (front)	Nut	M8	2	25	2.5	18.1	
Exhaust pipe and muffler	Screw	M8	2	20	2.0	14.5	
Muffler	Bolt	M10	2	25	2.5	18.1	
Crankcase (cylinder)	Stud bolt	M10	8	20	2.0	14.5	
Crankcase (cylinder)	Stud bolt	M8	2	13	1.3	9.4	
Crankcase	Bolt	M8	4	24	2.4	17.4	
Crankcase	Bolt	M6	10	10	1.0	7.2	
Bearing retainer (middle drive pinion gear)	Torx screw	M8	4	25	2.5	18.1	 Stake
Crankcase cover (left)	Bolt	M6	13	10	1.0	7.2	
Crankcase cover (right)	Bolt	M6	11	10	1.0	7.2	
Clamp	Bolt	M6	1	10	1.0	7.2	
One-way clutch	Bolt	M8	6	20	2.0	14.5	
Primary drive gear	Nut	M10	1	70	7.0	50.6	Use lock washer

MAINTENANCE SPECIFICATIONS

SPEC



Part to be tightened	Part name	Thread size	Q'ty	Tightening torque			Remarks
				Nm	m.kg	ft.-lb	
Clutch spring	Bolt	M6	5	8	0.8	5.8	
Clutch adjuster	Nut	M6	1	8	0.8	5.8	
Clutch boss	Nut	M20	1	70	7.0	50.6	Use lock washer
Push lever axle	Screw	M8	1	12	1.2	8.7	
Middle drive pinion gear	Nut	M20	1	120	12.0	86.8	Stake
Bearing retainer (middle driven shaft)	—	M65	1	110	11.0	79.6	
Yoke (middle driven shaft)	Nut	M14	1	90	9.0	65.1	
Bearing housing (middle drive shaft)	Bolt	M8	4	25	2.5	18.1	
Shift lever stopper	Bolt	M8	1	22	2.2	15.9	 Use lock washer
Shift pedal link	Bolt	M6	1	10	1.0	7.2	
Shift pedal adjuster	Nut	M6	2	7	0.7	5.1	1 of 2 has LH thread
Stator coil	Screw	M6	3	7	0.7	5.1	
Pickup coil	Screw	M6	3	7	0.7	5.1	

CHASSIS

Item	Standard	Limit
Steering system:		
Steering bearing type	Ball & taper roller bearing	----
No. / size of steel ball (upper)	19 pcs / 0.25 in	----
Front suspension:		
Front fork travel	140 mm (5.5 in)	----
Fork spring free length	332.5 mm (13.1 in)	325.9 mm (12.83 in)
Fitting length	287.4 mm (11.3 in)	----
Spring rate (K1)	3.5 N/mm (0.35 kg/mm, 19.6 lb/in)	----
Stroke (K1)	0 ~ 140 mm (0 ~ 5.5 in)	----
Optional spring	No	----
Oil capacity	0.507 L (17.14 US oz)	----
Oil level	95 mm (3.74 in)	----
Oil grade	Fork oil 10W or equivalent	----
Rear suspension:		
Shock absorber travel	42 mm (1.65 in)	----
Spring free length	179.5 mm (7.07 in)	165 mm (6.5 in)
Fitting length	165.5 mm (6.52 in)	----
Spring rate (K1)	137 N/mm (13.7 kg/mm, 6.52 lb/in)	----
Stroke (K1)	0 ~ 42 mm (0 ~ 1.65 in)	----
Optional spring	No	----
Swingarm:		
Free play limit	end	1 mm (0.04 in)
	side	1 mm (0.04 in)
Front wheel:		
Type	Spoke wheel	----
Rim size	16 × MT3.00	----
Rim material	Steel	----
Rim runout limit	radial	2 mm (0.08 in)
	lateral	2 mm (0.08 in)
Rear wheel:		
Type	Spoke wheel	----
Rim size	15M/C × MT3.50	----
Rim material	Steel	----
Rim runout limit	radial	2 mm (0.08 in)
	lateral	2 mm (0.08 in)



Item	Standard	Limit
Front brake:		
Type	Single disk	----
Disc outside diameter × thickness	298 × 5 mm (11.73 × 0.2 in)	----
Pad thickness inner	6.0 mm (0.24 in)	0.8 mm (0.03 in)
Pad thickness outer	6.0 mm (0.24 in)	0.8 mm (0.03 in)
		
Master cylinder inside diameter	14.0 mm (0.55 in)	----
Caliper cylinder inside diameter	30.2 mm (1.19 in)	----
Caliper cylinder inside diameter	33.3 mm (1.31 in)	----
Brake fluid type	DOT 4	----
Rear brake:		
Type	Leading, trailing	----
Brake drum inside diameter	200 mm (7.87 in)	201 mm (7.9 in)
Lining thickness	4 mm (0.16 in)	2 mm (0.08 in)
Shoe spring free length	68 mm (2.68 in)	----
Brake lever & brake pedal:		
Brake lever free play (at pivot)	1 ~ 2 mm (0.04 ~ 0.08 in)	----
Brake lever free play (at lever end)	10 ~ 15 mm (0.39 ~ 0.59 in)	----
Brake pedal position	85 m (3.35 in)	----
Brake pedal free play	20 ~ 30 mm (0.79 ~ 1.18 in)	----
Clutch lever free play (at pivot)	2 ~ 3 mm (0.08 ~ 0.12 in)	----
Clutch lever free play (at lever end)	10 ~ 15 mm (0.39 ~ 0.59 in)	----



Tightening torques

Part to be tightened	Thread size	Tightening torque			Remarks
		Nm	m-kg	ft-lb	
Upper bracket and inner tube	M8	20	2.0	14.5	See NOTE
Lower bracket and inner tube	M10	30	3.0	21.7	
Upper bracket and steering shaft	M22	110	11.0	79.6	
Ring nut (steering shaft)	-	18	1.8	13.0	
Handlebar holder (lower) and upper bracket	M12	20	2.0	14.5	
Handlebar holder (lower) and handlebar holder (upper)	M8	23	2.3	16.6	
Master cylinder (front brake)	M6	10	1.0	7.2	
Union bolt (brake hose)	M10	30	3.0	21.7	
Brake hose holder and lower bracket	M6	9	0.9	6.5	
Front fender and outer tube	M8	10	1.0	7.2	
Headlight stay and lower bracket	M6	7	0.7	5.1	
Headlight stay and headlight	M6	8	0.8	5.8	
Front flasher light and lower bracket	M6	7	0.7	5.1	
Engine mounting:					
Frame and stay (front - upper)	M8	40	4.0	28.9	
Frame and stay (front - lower)	M8	30	3.0	21.7	
Stay and engine (front - upper)	M10	40	4.0	28.9	
Stay and engine (front - lower)	M10	40	4.0	28.9	
Frame and engine (rear - upper)	M10	40	4.0	28.9	
Frame and engine (rear - lower)	M12	74	7.4	53.5	
Regulator stay and frame	M6	13	1.3	9.4	
Regulator and regulator stay	M6	7	0.7	5.1	
Muffler stay and frame	M8	30	3.0	21.7	
Rear shock absorber and swingarm	M12	62	6.2	44.8	
Rear shock absorber and frame	M12	62	6.2	44.8	
Pivot shaft (left) and frame	M22	100	10.0	72.3	
Pivot shaft (right) and frame	M22	7	0.7	5.1	
Pivot shaft (right) and locknut	M22	100	10.0	72.3	
Final gear case and swingarm	M10	70	7.0	50.6	
Fuel tank and fuel cock	M6	7	0.7	5.1	
Fuel tank bracket and frame	M8	23	2.3	16.6	
Rider's seat	M6	7	0.7	5.1	
Passenger seat	M6	7	0.7	5.1	
Frame and rear fender stay	M10	26	2.6	18.8	
Rear fender and rear fender stay	M8	26	2.6	18.8	
Rear fender and tail/brake light	M6	6	0.6	4.3	
Rear fender stay and rear flasher light	M12	23	2.3	16.6	
Side cover (lower)	M6	7	0.7	5.1	
Battery cover	M6	7	0.7	5.1	
Side cover (right)	M6	7	0.7	5.1	
Starter relay and leads	M6	7	0.7	5.1	

MAINTENANCE SPECIFICATIONS

SPEC



Part to be tightened	Thread size	Tightening torque			Remarks
		Nm	m·kg	ft·lb	
Passenger footrest and frame	M8	26	2.6	18.8	
Sidestand bracket and frame	M10	56	5.6	40.5	
Sidestand and sidestand bracket	M10	56	5.6	40.5	
Sidestand switch	M5	4	0.4	2.9	
Brake pedal/footrest and frame	M6	64	6.4	46.3	
Front wheel axle	M16	59	5.9	42.6	
Front wheel axle pinch bolt	M8	20	2.0	14.5	
Brake caliper	M10	40	4.0	28.9	
Brake disc and front wheel	M8	23	2.3	16.6	
Caliper bleed screw	M7	6	0.6	4.3	
Rear wheel axle nut	M14	97	9.7	70.2	
Tension bar and swingarm	M8	20	2.0	14.5	
Tension bar and brake shoe plate	M8	20	2.0	14.5	
Brake cam shaft lever	M6	10	1.0	7.2	
Clutch hub and damper	M10	62	6.2	44.8	
Final gear case (housing cover)	M10	18	1.8	13.0	
Bearing housing (final gear case)	M8	23	2.3	16.6	
Bearing housing (final gear case)	M10	23	2.3	16.6	
Bearing retainer (final drive pinion gear)	M65	115	11.5	83.2	LH thread
Oil filter bolt (final gear)	M14	23	2.3	16.6	
Oil drain bolt (final gear)	M14	23	2.3	16.6	
Housing cover	M10	42	4.2	30.4	

NOTE:

1. First, tighten the ring nut approximately 52 Nm (5.2 m · kg, 37.6 ft · lb) by using the torque wrench, then loosen the ring nut completely.
2. Retighten the ring nut to specification.



ELECTRICAL

Item	Standard	Limit
Voltage:	12 V	----
Ignition system:		
Ignition timing (B.T.D.C.)	12° at 1,200 r/min	----
Advancer type	TPS and electrical type	----
T.C.I.:		
Pickup coil resistance / color	182 ~ 222 Ω at 20°C / Gray – Black	----
T.C.I. unit model / manufacturer	J4T079 / MITSUBISHI	----
Ignition coil:		
Model / manufacturer	F6T541 / MITSUBISHI	----
Minimum spark gap	6 mm (0.24 in)	----
Primary winding resistance	3.8 ~ 4.6 Ω at 20°C	----
Secondary winding resistance	10.1 ~ 15.1 kΩ at 20°C	----
Spark plug cap:		
Type	Resin type	----
Resistance	10 kΩ	----
Charging system:		
Type	A.C. magneto	----
Model / manufacturer	F4T459 / MITSUBISHI	----
Nominal output	14 V 20 A at 5,000 r/min	----
Stator coil resistance / color	0.50 ~ 0.62 Ω at 20°C / White – White	----
Voltage regulator:		
Type	Semi-conductor, short-circuit type	----
Model / manufacturer	SH650D-11 / SHINDENGEN	----
No load regulated voltage	14.1 ~ 14.9 V	----
Rectifier:		
Model / manufacturer	SH650D-11 / SHINDENGEN	----
Capacity	18 A	----
Withstand voltage	200 V	----
Battery:		
Specific gravity	1.320	----
Electric starter system:		
Type	Constant mesh type	----
Starter motor:		
Model / manufacturer	SM-13 / MITSUBA	----
I.D. number	SM-13	----
Output	0.7 kW	----
Brush overall length	12.5 mm (1.48 in)	4 mm (0.47 in)
Commutator diameter	28 mm (3.31 in)	27 mm (3.19 in)
Mica undercut	0.7 mm (0.08 in)	----
Starter relay:		
Model / manufacturer	MS-5F / JIDECO	----
Amperage rating	100 A	----

MAINTENANCE SPECIFICATIONS

SPEC



Item	Standard	Limit
Horn:		
Type	Plane type	----
Quantity	1	----
Model / manufacturer	YF-12 / NIKKO	----
Maximum amperage	3.0 A	----
Flasher relay:		
Type	Full transistor type	----
Model / manufacturer	FE257BH / DENSO	----
Self cancelling device	Yes	----
Flasher frequency	75 ~ 95 cycle/min	----
Wattage	27 W × 2 + 3.4W	----
Fuel pump relay:		
Model / manufacturer	G8R-30Y / OMRON	----
Circuit breaker:		
Type	Fuse	----
Amperage for individual circuit		
MAIN	30 A × 1	----
HEAD LIGHT	15 A × 1	----
SIGNALS	10 A × 1	----
IGNITION	10 A × 1	----
Reserve	30 A × 1	----
Reserve	15 A × 1	----
Reserve	10 A × 1	----

EB202001

GENERAL TORQUE SPECIFICATIONS

This chart specifies torque for standard fasteners with standard I.S.O. pitch threads. Torque specifications for special components or assemblies are provided for each chapter of this manual. To avoid warpage, tighten multi-fastener assemblies in a criss-cross fashion, in progressive stages, until the specified torque is reached. Unless otherwise specified, torque specifications require clean, dry threads. Components should be at room temperature.

A (nut)	B (bolt)	General torque specifications		
		Nm	m•kg	ft•lb
10 mm	6 mm	6	0.6	4.3
12 mm	8 mm	15	1.5	11
14 mm	10 mm	30	3.0	22
17 mm	12 mm	55	5.5	40
19 mm	14 mm	85	8.5	61
22 mm	16 mm	130	13.0	94

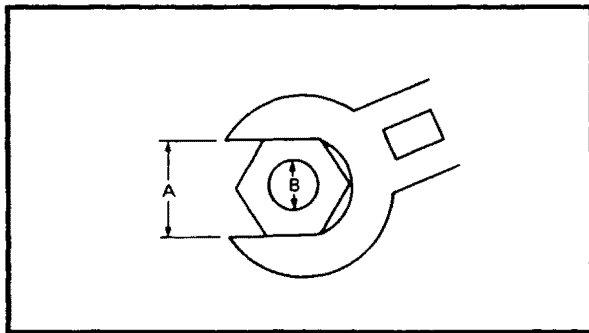

A: Distance between flats
B: Outside thread diameter



EB203000

LUBRICATION POINTS AND LUBRICANT TYPES

ENGINE

Lubrication point	Symbol
Oil seal lips	
O-ring	
Bearing	
Connecting rod bolt/nut	
Connecting rod small end and big end	
Crankshaft pin	
Crankshaft journal/big end	
Piston surface	
Piston pin	
Camshaft cam lobe/journal	
Rocker arm shaft	
Valve stem (IN, EX)	
Valve stem end (IN, EX)	
Oil pump rotor (inner/outer), housing	
Idle gear surface	
Starter idle gear	
Starter idle gear shaft	
Middle drive gear	
Primary driven gear	
Push rod 1	
Transmission gear (wheel/pinion)	
Shift cam	
Shift fork/guide bar	
Shift shaft assembly	
Valve spring (intake)	
Push rod ball	
Push lever assembly	

LUBRICATION POINTS AND LUBRICANT TYPES

SPEC



EB203010

CHASSIS

Lubrication point	Symbol
Steering head pipe (upper/lower), bearing	
Steering head pipe, bearing cover lip	
Steering head pipe, oil seal lip	
Front wheel oil seal lip (right/left)	
Rear wheel oil seal lip	
Clutch hub fitting area	
Rear brake pedal shaft	
Shift pedal shaft	
Sidestand bolt, sidestand sliding surface	
Tube guide (throttle grip) inner surface	
Brake lever pivot bolt, contact surface	
Clutch lever pivot bolt, contact surface	
Rear shock absorber (lower) oil seal lip	
Swingarm pivot bearing inner surface	
Swingarm pivot oil seal lip	



EB205000

LUBRICATION DIAGRAMS

- ① Rocker arm (intake)
- ② Rocker arm (exhaust)
- ③ Camshaft

- ④ Drain bolt
- ⑤ Oil strainer
- ⑥ Push lever

- ⑦ Push rod 1
- ⑧ Oil pump

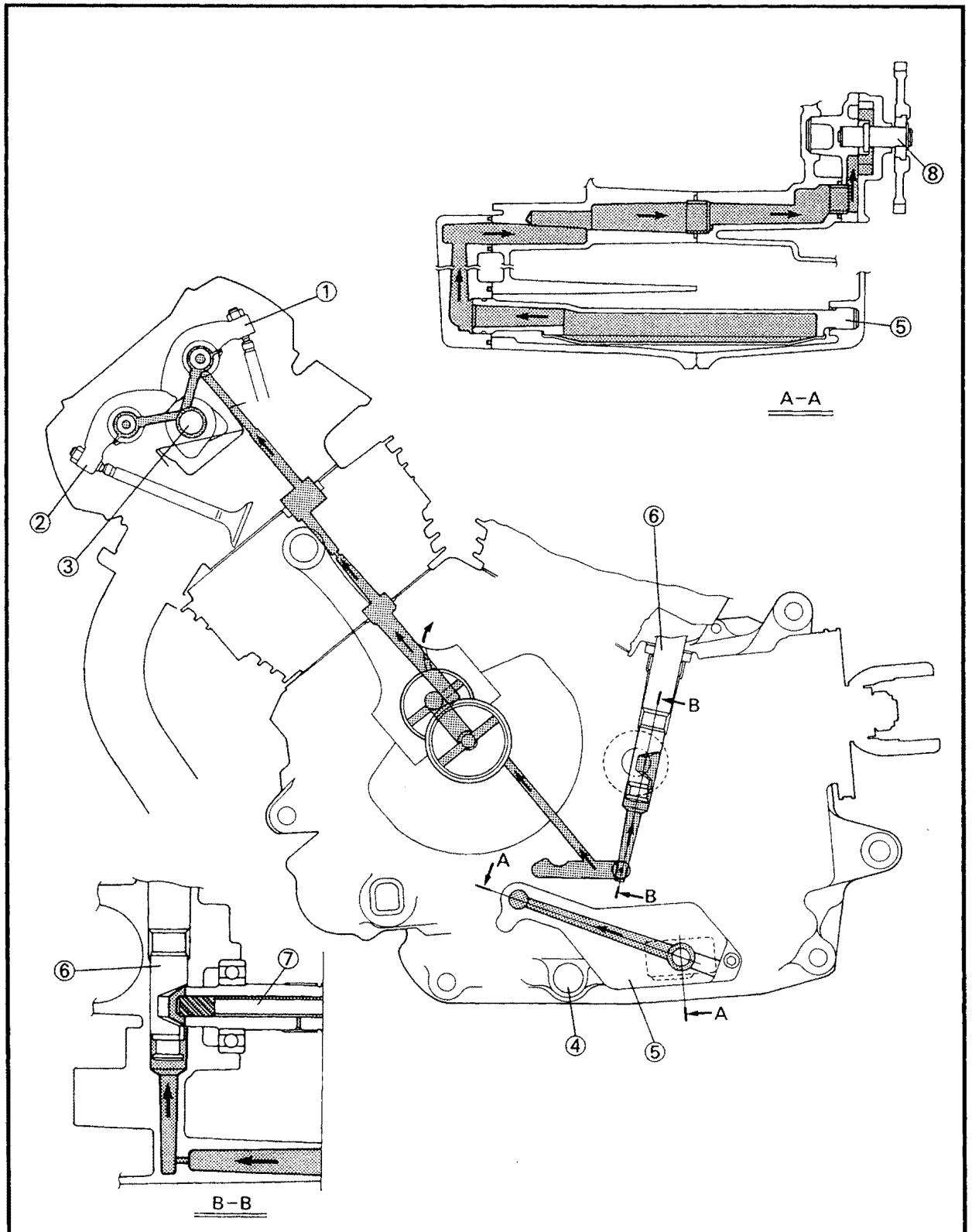

LUBRICATION DIAGRAMS

SPEC



- ① Rocker arm shaft (intake)
- ② Rocker arm shaft (exhaust)
- ③ Camshaft

- ④ Drive axle
- ⑤ Relief valve
- ⑥ Oil pump

- ⑦ Oil filter
- ⑧ Crankshaft

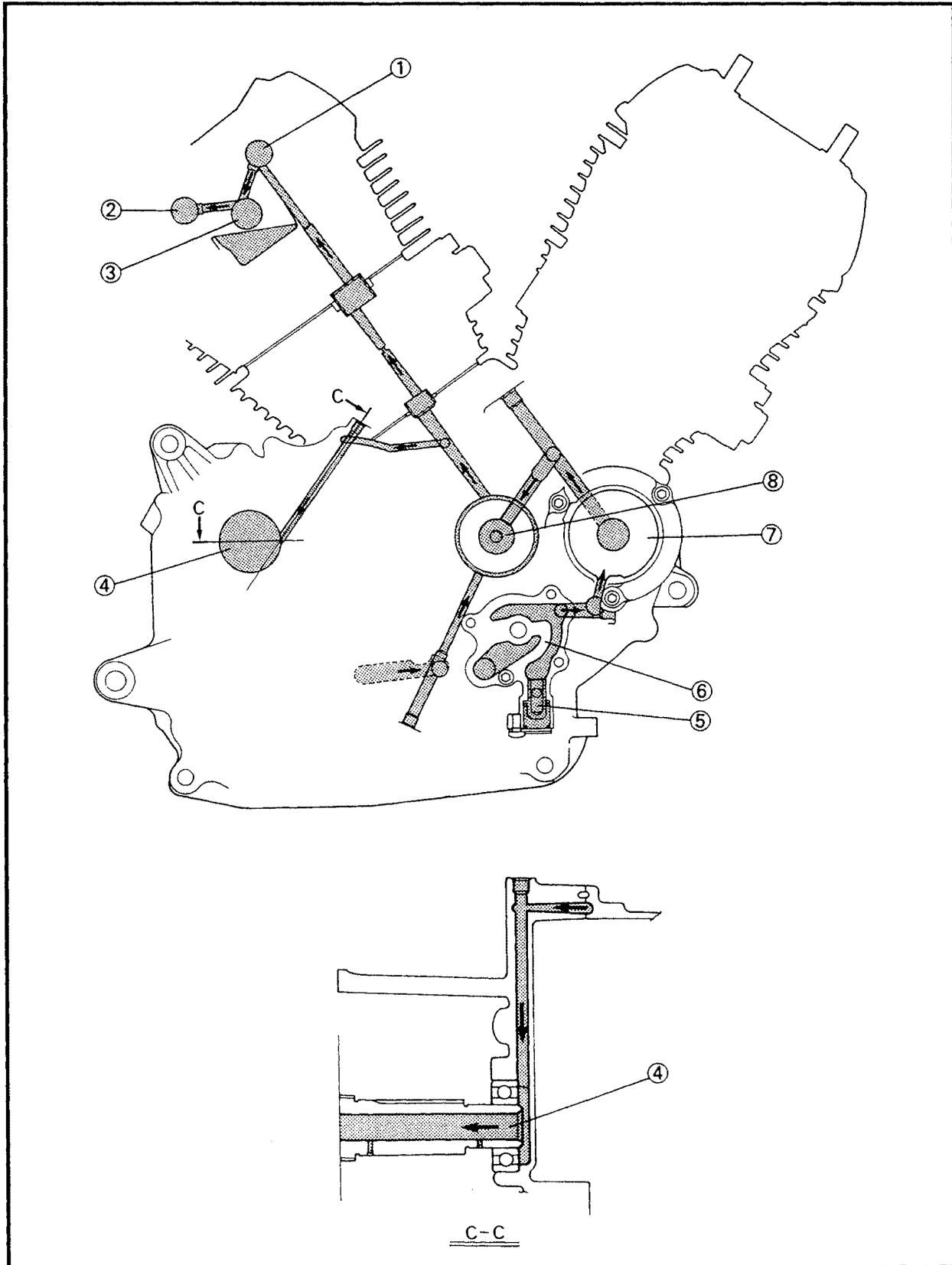



- ① Crankshaft
- ② Oil filter
- ③ Oil pump

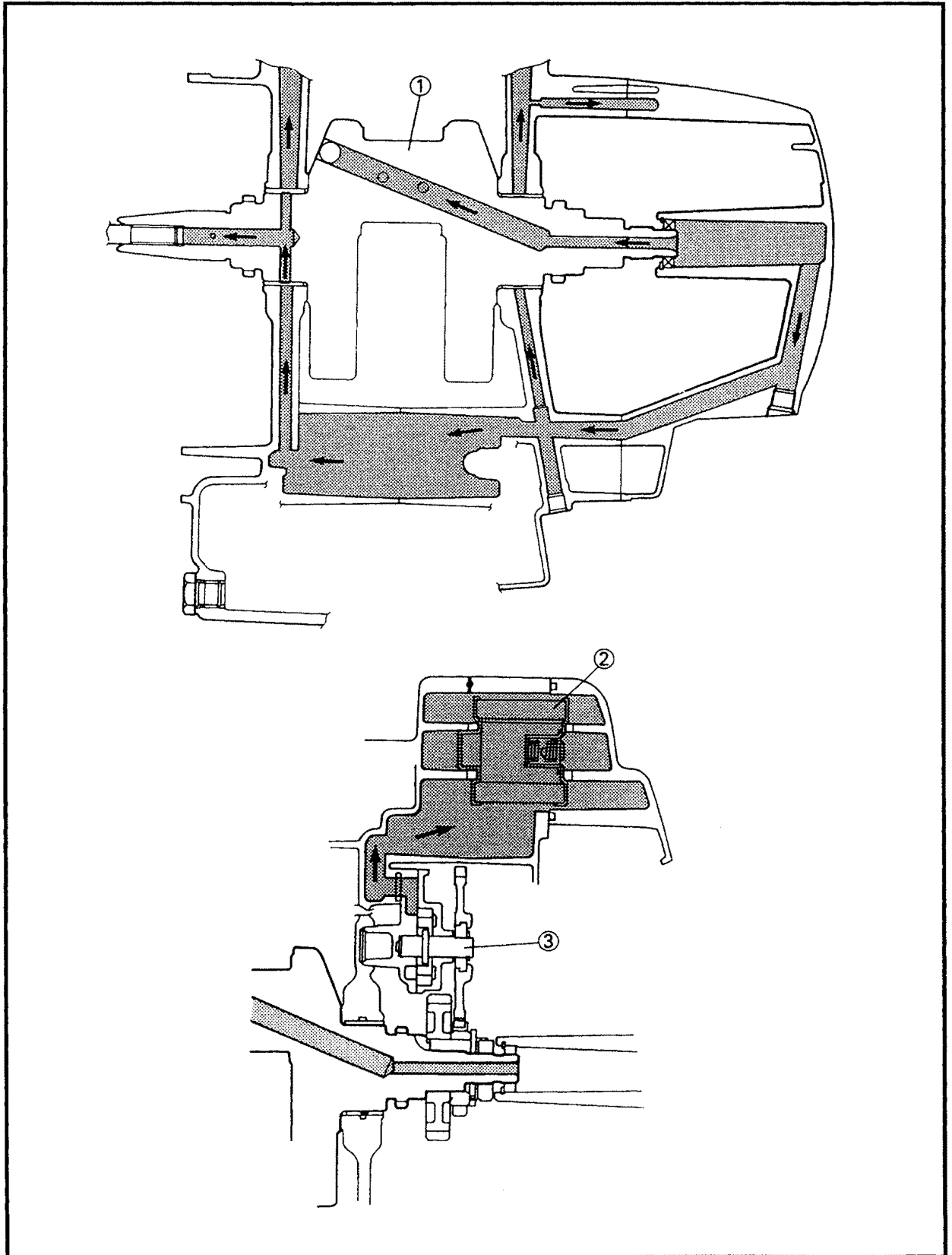



- ① Camshaft
- ② Rocker arm
- ③ Starter idle gear

- ④ Drive axle
- ⑤ Main axle

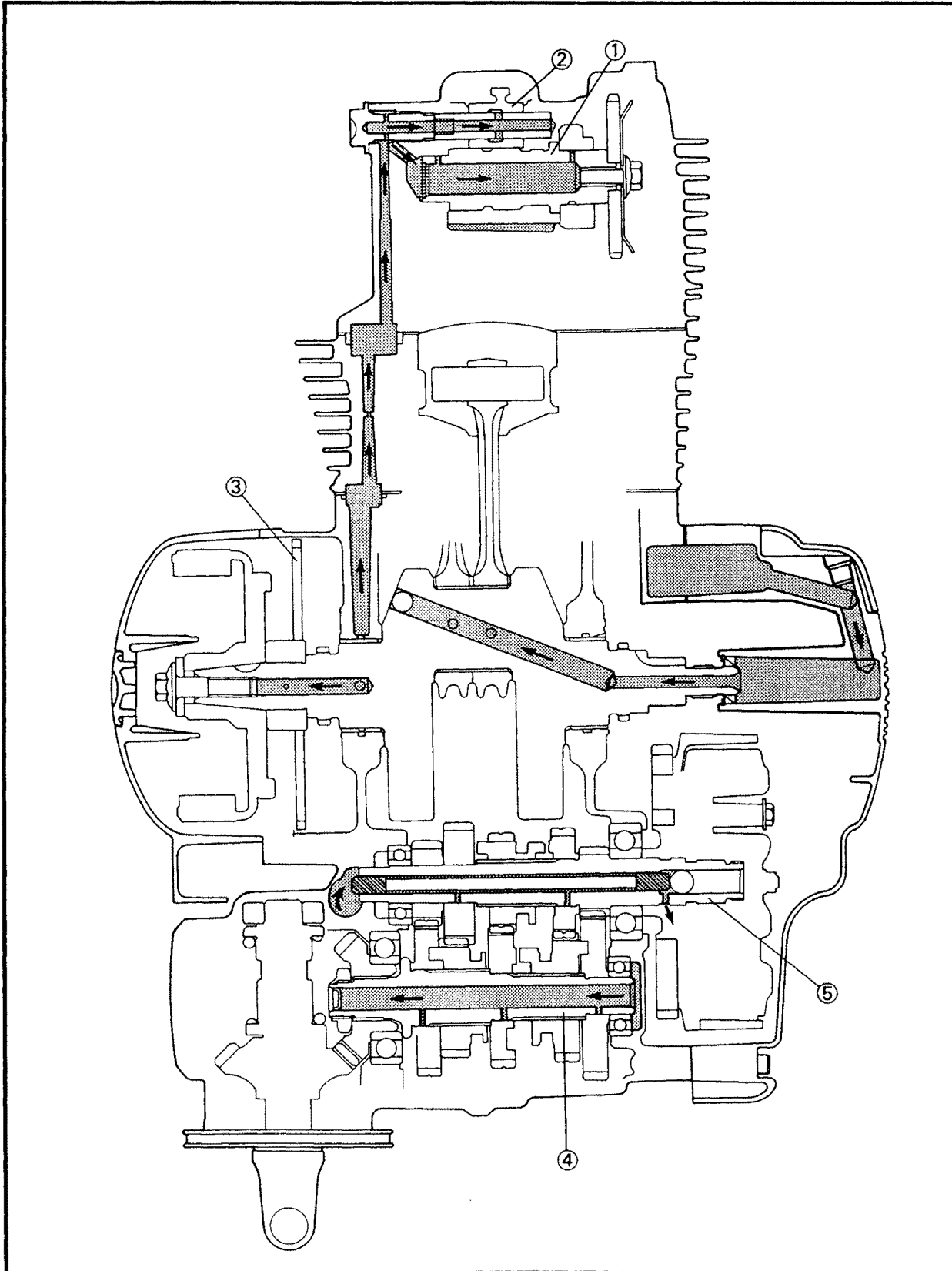



EB206000

CABLE ROUTING

- | | |
|------------------------------|-------------------------------|
| ① Clutch cable | ⑩ Horn |
| ② Left handlebar switch lead | ⑪ Headlight lead |
| ③ Fuel tank breather hose | ⑫ Right handlebar switch lead |
| ④ Speedometer cable | ⑬ Spark plug lead |
| ⑤ Speedometer | ⑭ Fuel hose |
| ⑥ Speedometer light leads | ⑮ Main switch lead |
| ⑦ Rectifier/regulator | ⑯ Fuel pump lead |
| ⑧ Rear brake switch lead | ⑰ Main switch |
| ⑨ Sidestand switch lead | ⑱ Fuel pump |

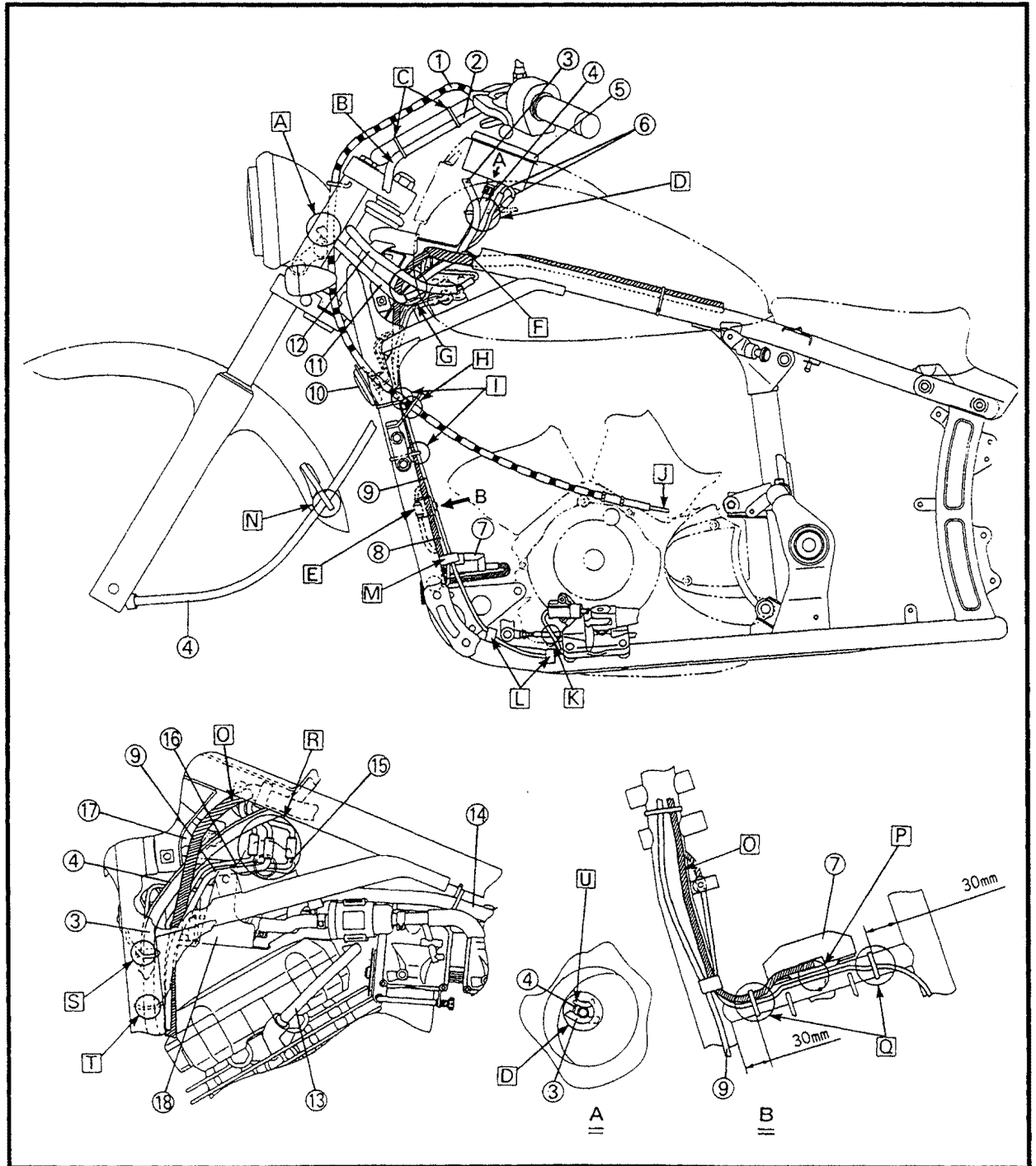

CABLE ROUTING

SPEC



- A** Pass the front flasher light leads (left and right) and headlight lead through the headlight cover hole.
- B** Pass the left handlebar switch lead behind the upper bracket.
- C** Fasten the left handlebar switch lead with a plastic locking tie.
- D** Pass the speedometer cable, speedometer light leads and fuel tank breather hose through the fuel tank hole.
- E** Connect the rear brake switch coupler in front of the roll over valve stay.
- F** To the speedometer light leads.
- G** Pass the right handlebar switch lead and headlight lead over the other harness and leads.
- H** Pass the clutch cable through the cable guide.
- I** Fasten the sidestand switch lead and rectifier/regulator lead with a plastic locking tie.
- J** To the engine.
- K** The sidestand switch lead should not touch the shift rod.

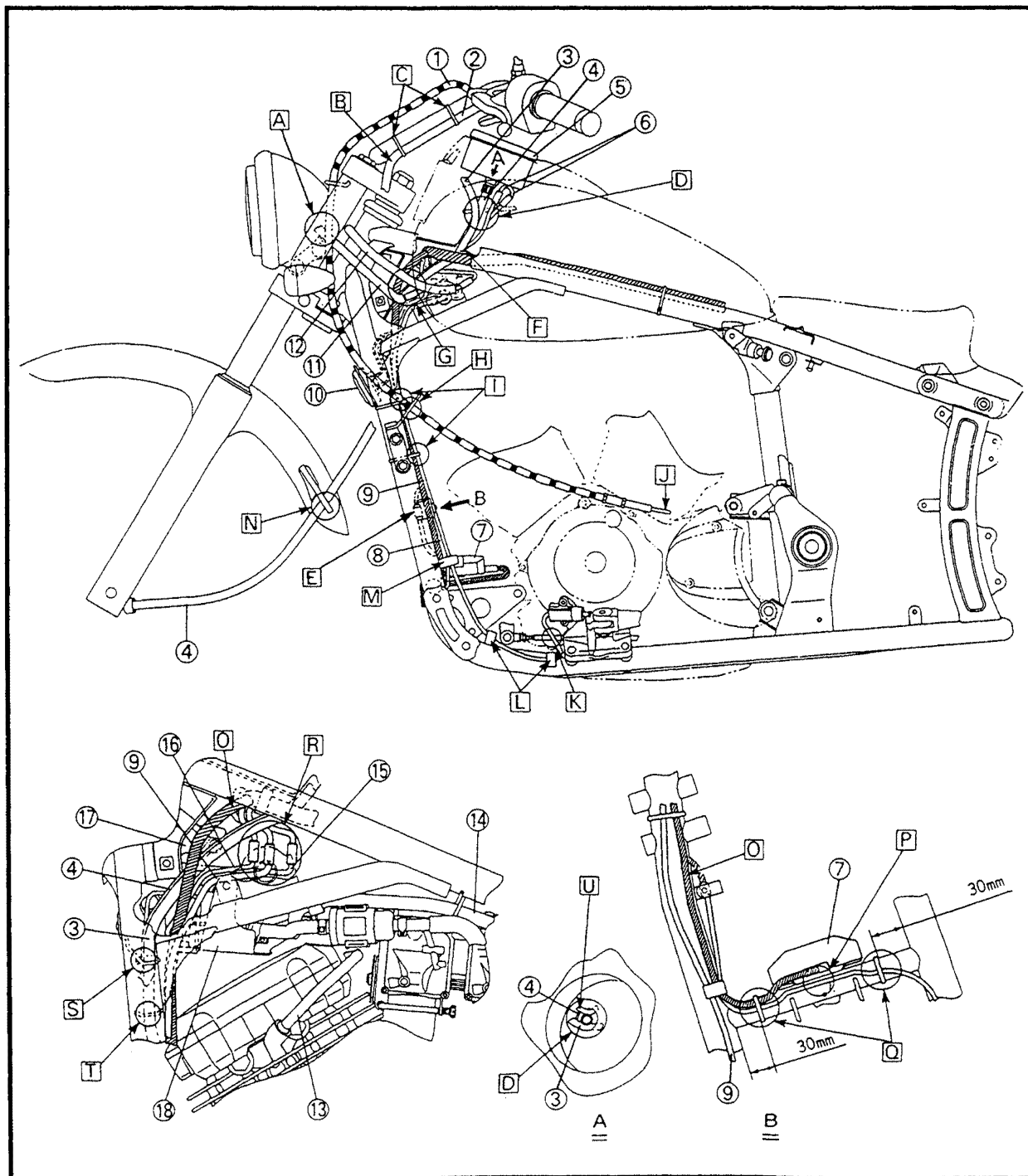



- L** Fasten the sidestand switch lead with a metal clamp.
- M** Fasten the rear brake switch lead, sidestand switch lead and rectifier/regulator lead with a metal clamp.
- N** Pass the speedometer cable through the speedometer cable holder.
- O** To the rectifier/regulator.
- P** Pass the rear brake switch lead between the frame and rectifier/regulator. Do not pinch the rear brake switch lead.
- Q** Fasten the rear brake switch lead and rectifier/regulator lead with a plastic locking tie.
- R** Place the couplers behind the steering head.
- S** Pass the speedometer cable through the holder.
- T** Pass the fuel tank breather hose through the holder.
- U** To the speedometer light leads.

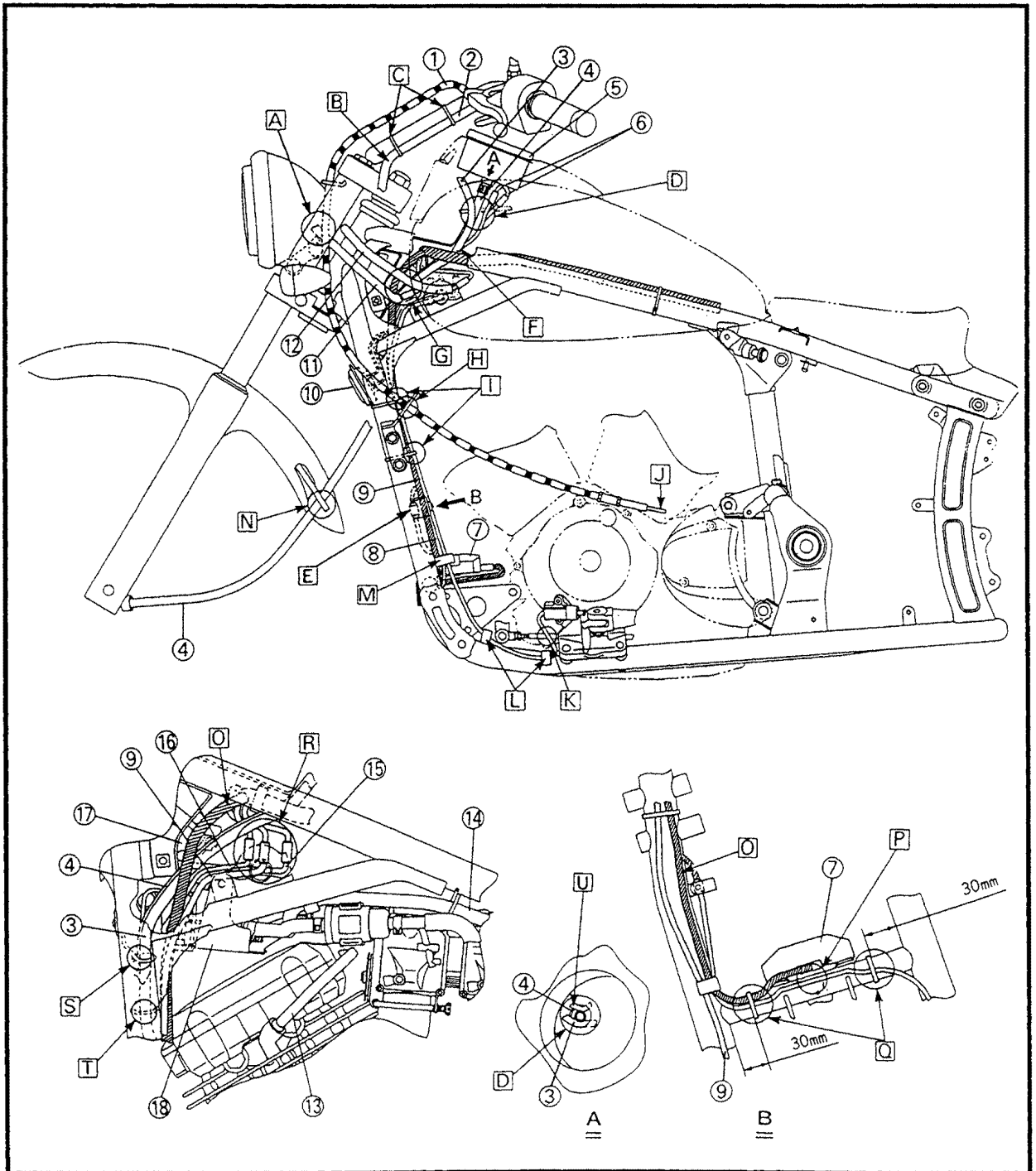



- | | | |
|-------------------------------|----------------------------------|---|
| ① Frame bracket | ⑫ Starter relay | Ⓐ Pass the tail/brake light lead between the frame bracket and battery box. |
| ② Wire harness | ⑬ Carburetor heater relay | Ⓑ Fasten the tail/brake light lead with a battery band. Do not pinch the harness and tail/brake light lead. |
| ③ Fuse box | ⑭ Neutral switch lead | Ⓒ To the ignition coil. |
| ④ Battery positive (+) lead | ⑮ Pickup coil lead | Ⓓ The end of the plastic locking tie should face towards the under the handlebar. |
| ⑤ Spark plug lead | ⑯ A.C. magneto lead | |
| ⑥ Starter cable | ⑰ Battery negative (-) lead | |
| ⑦ Right handlebar switch lead | ⑱ Starter motor lead | |
| ⑧ Brake hose | ⑲ Starting circuit cut-off relay | |
| ⑨ Throttle cables | ⑳ Fuel tank breather hose | |
| ⑩ Thermo switch lead | ㉑ Speedometer cable | |
| ⑪ Flasher light relay | ㉒ Ignitor unit | |

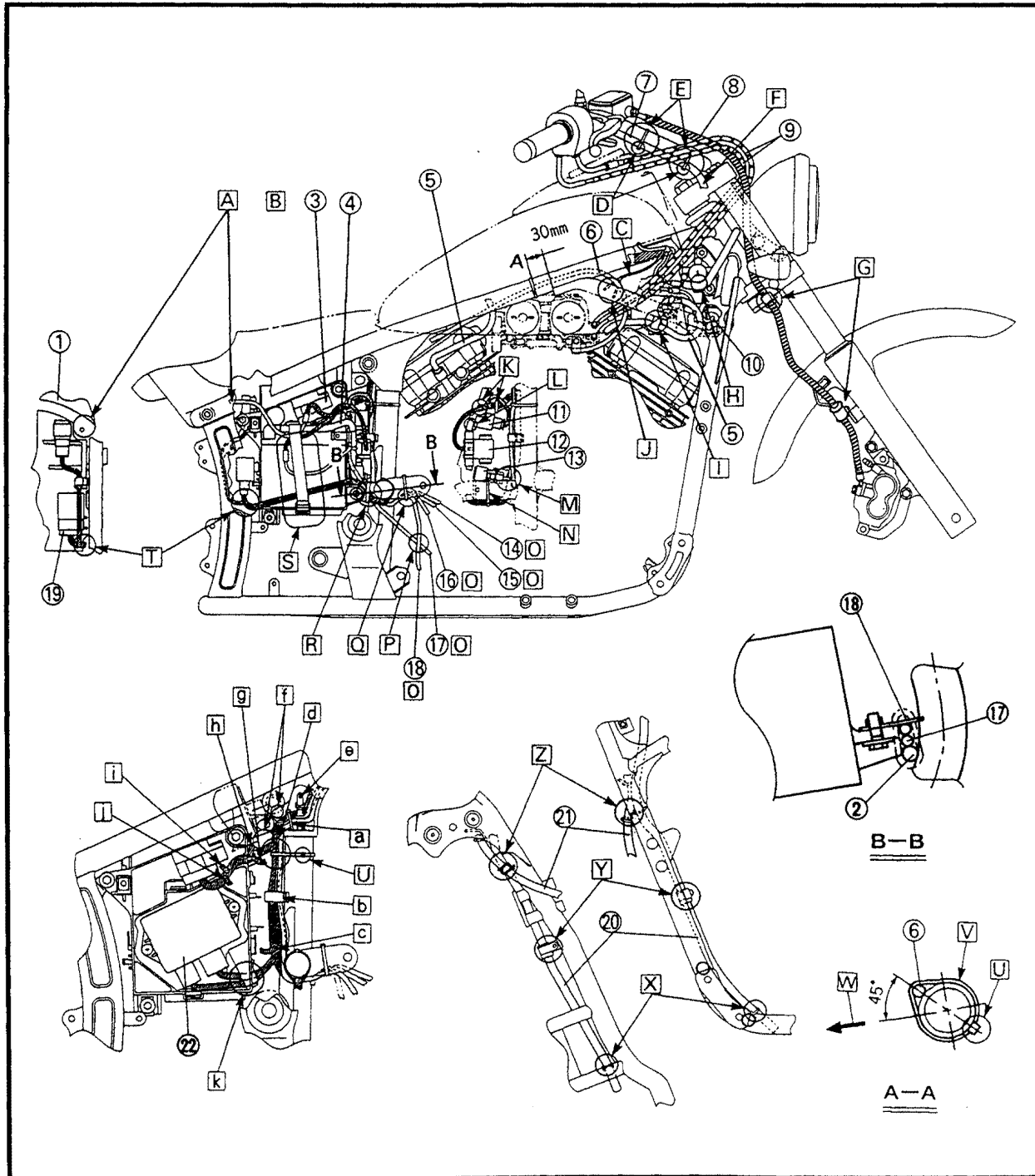



- E Fasten the right handlebar switch lead with a plastic locking tie.
- F Pass the right handlebar switch lead behind the upper bracket.
- G Fasten the brake hose with a brake hose holder.
- H Pass the left handlebar switch lead under the main switch.
- I Fasten the spark plug lead with a metal clamp.
- J Pass the ignition coil lead inside of the starter cable.
- K Fasten the fuse box lead with a plastic locking tie.
- L Fasten the battery positive (+) lead with a battery box clamp.
- M The carburetor heater relay should not touch the wire harness.
- N Fasten the wire harness with a plastic locking tie.
- O From the engine.
- P Pass the starter motor lead over the battery negative (-) lead.

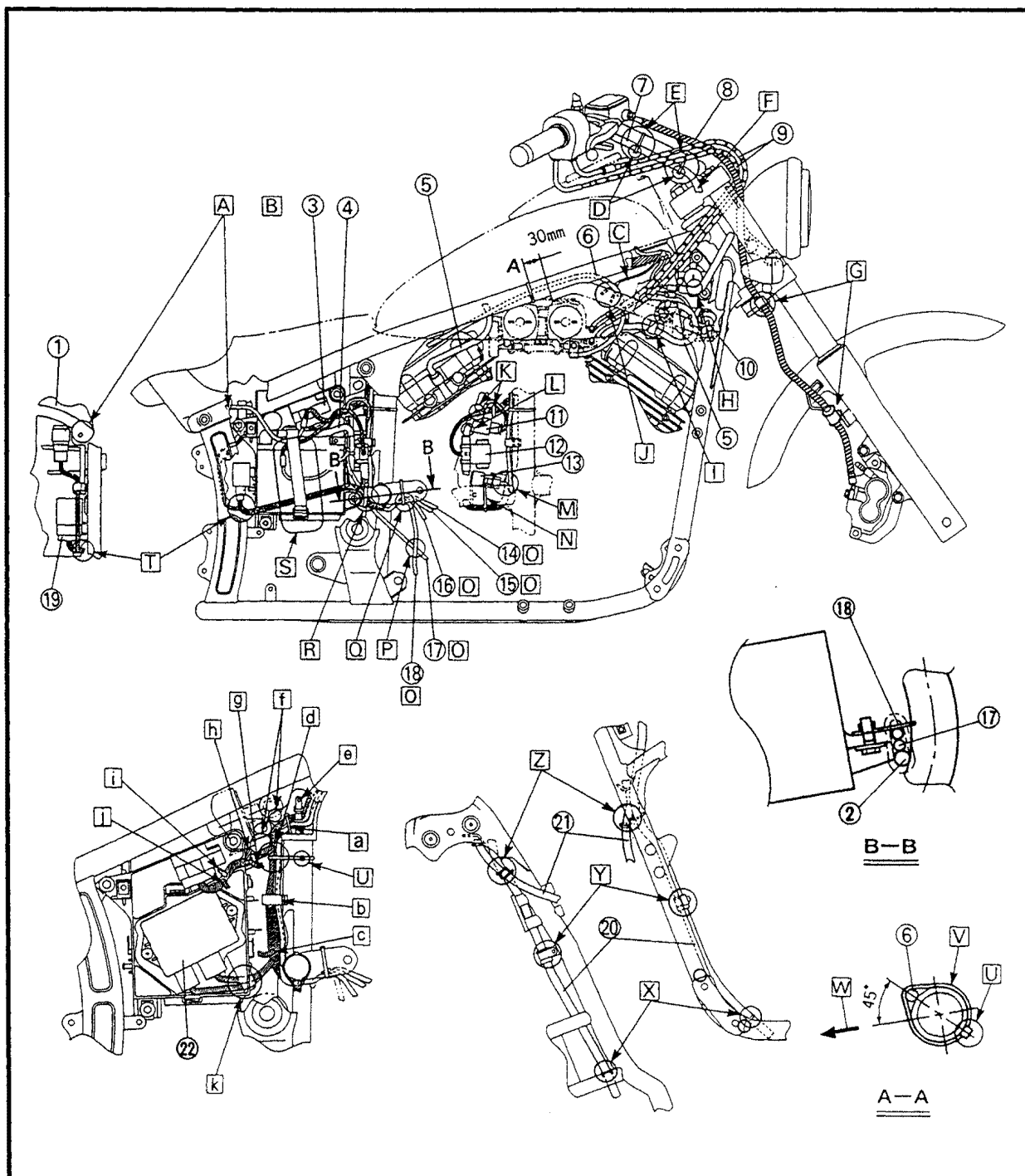

- Q Fasten the pickup coil lead, A.C. magneto lead, neutral switch lead and starter motor lead with a plastic locking tie.
- R Fasten the battery negative (-) lead, starter motor lead and wire harness with a plastic locking tie.
- S Fasten the wire harness with a battery band.
- T Pass the wire harness between the frame and battery box.
- U Place the end of the plastic locking tie as shown.
- V Fasten the starter cable with a plastic locking tie.
- W Inside the motorcycle.
- X Pass the fuel tank breather hose through the holder.
- Y Fasten the fuel tank breather hose with a metal clamp.
- Z Pass the speedometer cable through the front side guide.
- a Fasten the wire harness and leads with a plastic locking tie.

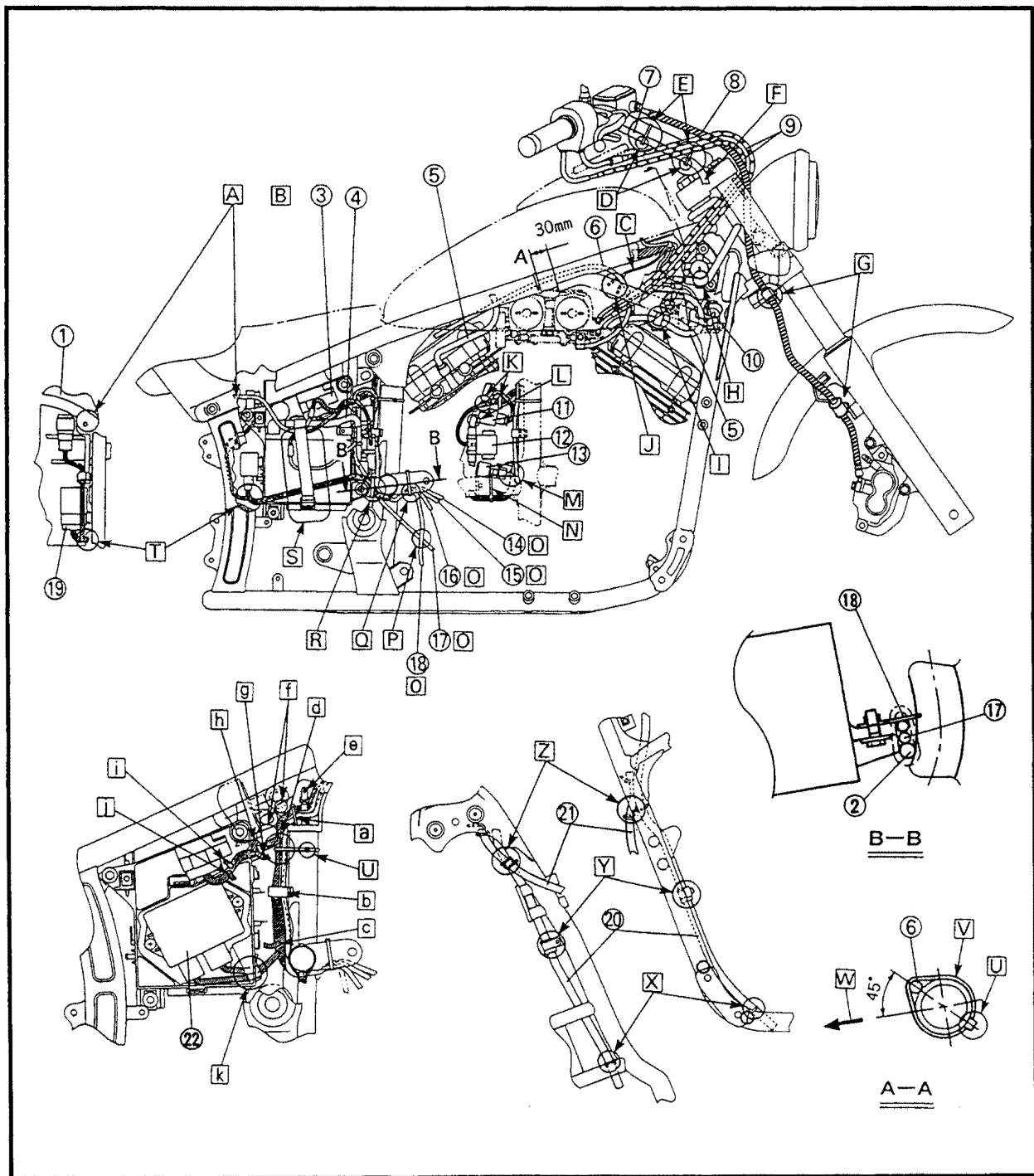



- b Fasten the wire harness and leads with a metal clamp.
- c To the carburetor heater relay.
- d Fasten the wire harness and leads with a plastic locking tie.
- e Pass the plastic band through the frame hole. Fasten the wire harness with a plastic band at the point where the tape is located.
- f The wire harness and leads should not touch the rear shock absorber.
- g To the starter relay.
- h To the flasher light relay.
- i To the rear fender.
- j To the battery negative (-) lead.
- k Pass the ignitor unit leads through the battery box hole.

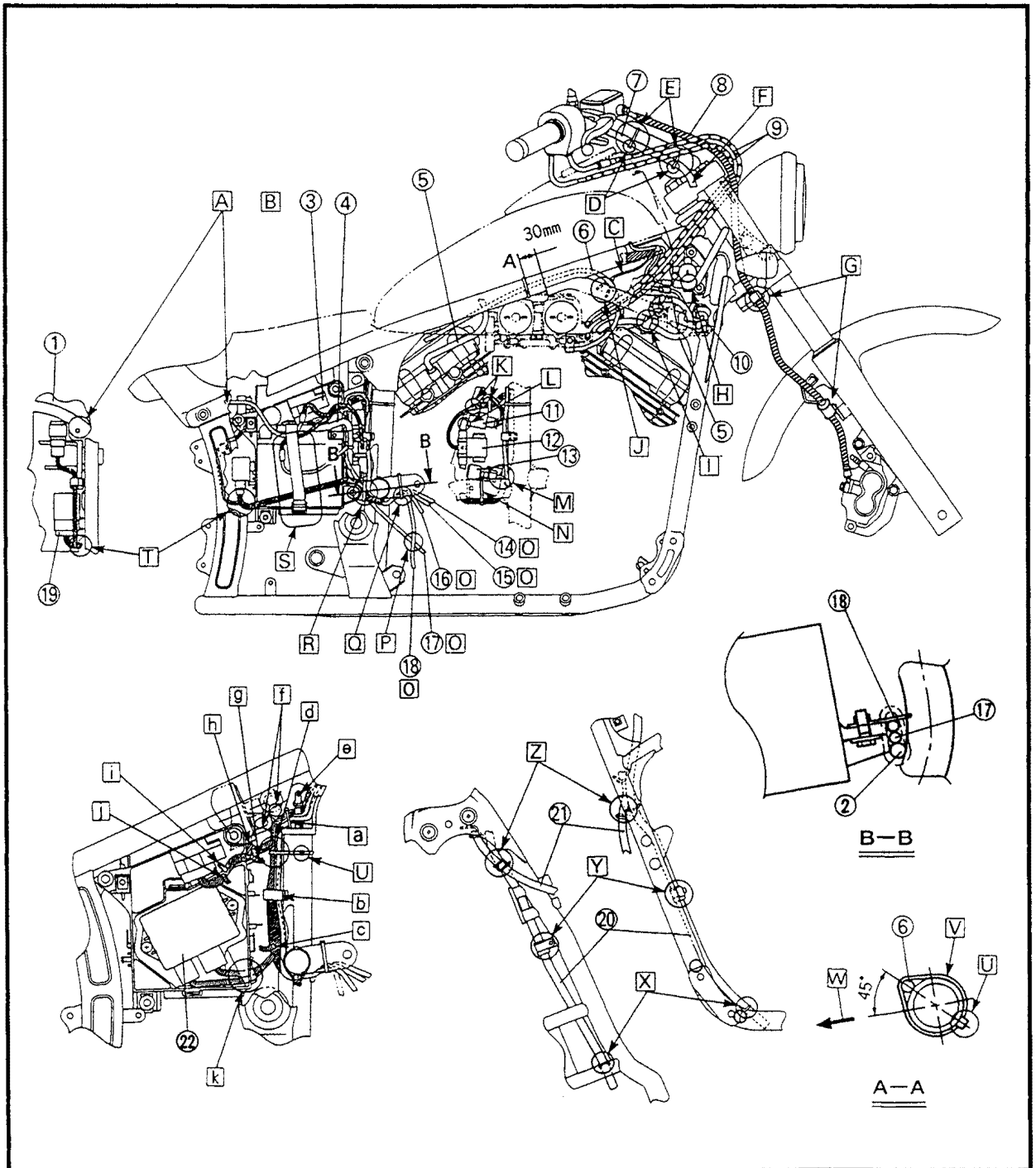



- | | | |
|-------------------------------|---------------------------|---|
| ① Front flasher light (right) | ⑫ Speedometer cable | Ⓐ Pass the throttle cables through the cable guide. |
| ② Throttle cables | ⑬ Neutral switch lead | Ⓑ Pass the brake hose in front of the upper bracket. |
| ③ Brake hose | ⑭ Pickup coil lead | Ⓒ Pass the left handlebar switch lead over the right handlebar switch lead. |
| ④ Right handlebar switch lead | ⑮ A.C. magneto lead | Ⓓ Pass the clutch cable through the cable guide. |
| ⑤ Clutch cable | ⑯ Thermo switch lead | Ⓔ Fasten the handlebar switch leads with a plastic band. |
| ⑥ Left handlebar switch lead | ⑰ Fuel tank breather hose | Ⓕ Fasten the wire harness with a plastic locking tie. |
| ⑦ Front flasher light (left) | ⑱ Frame | |
| ⑧ Ignition coil | ⑲ Wire harness | |
| ⑨ Spark plug lead | ⑳ Air filter case | |
| ⑩ Silencer | | |
| ⑪ Starter cable | | |

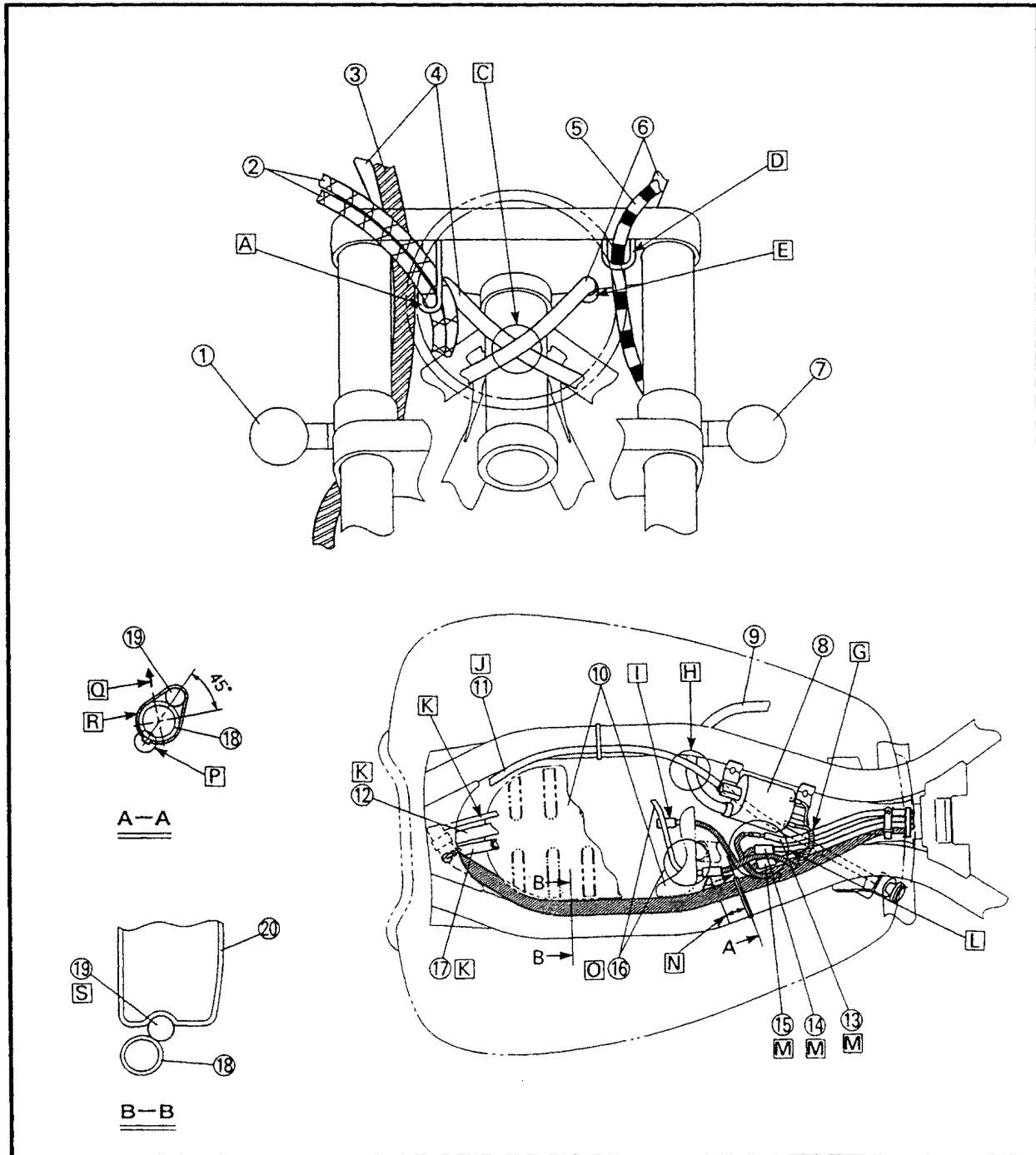



- G** To the ignition coil.
- H** Pass the starter cable between the ignition coil and spark plug lead.
- I** To the throttle position sensor (TPS).
- J** To the carburetor.
- K** To the fuel tank.
- L** Pass the neutral switch lead, pickup coil lead and A.C. magneto lead under the ignition coil lead, thermo switch lead and throttle position sensor (TPS) lead.
- M** From the engine.
- N** 20 mm (0.79 in)
- O** Pass the thermo switch lead inside of the silencer breather hose.
- P** Place the end of the plastic locking tie as shown.
- Q** Inside the motorcycle.
- R** Fasten the wire harness with a plastic locking tie.
- S** Pass the wire harness between the air filter case groove and frame.

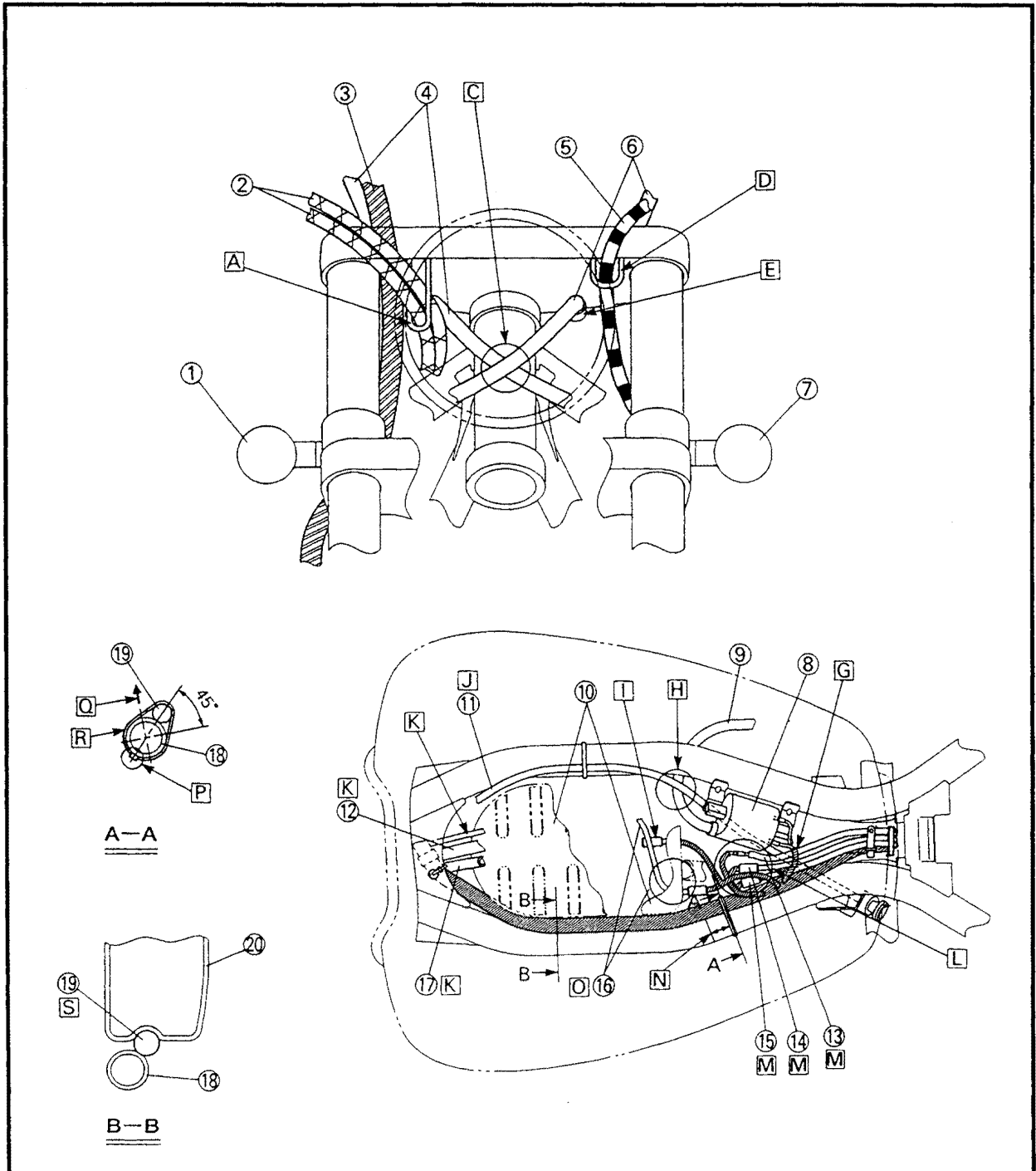



- ① Fuel tank breather hose
- ② Carburetor
- ③ Fuel hose
- ④ Fuel filter
- ⑤ Spark plug lead
- ⑥ Fuel pump lead
- ⑦ Fuel pump
- ⑧ Rollover valve
- ⑨ Ignition coil

- A To the rollover valve
- B To the engine
- C From the fuel cock
- D Position the hose clip tabs downward.
- E From the fuel tank
- F The longer stem on the rollover valve faces up.
- G The tabs on both hose clips should face in the same direction.

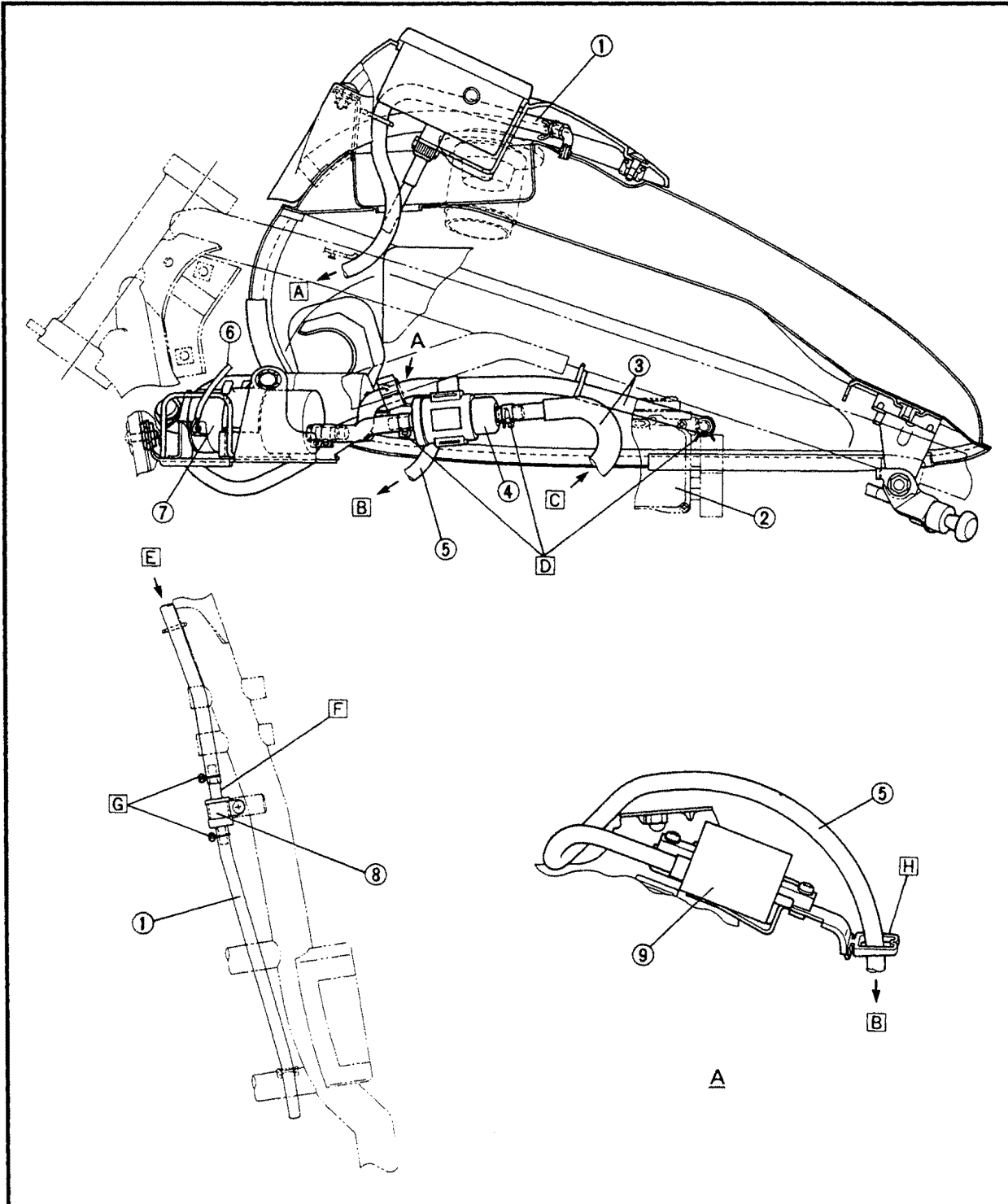



- ① Thermo switch
- ② Spark plug lead
- ③ Fuel tank breather hose
- ④ Carburetor
- ⑤ Fuel filter
- ⑥ Fuel cock
- ⑦ Fuel hose
- ⑧ Fuel pump
- ⑨ Ignition coil

- A Position the spark plug lead in front of the fuel tank.
- B Pass the fuel tank breather hose through the hose guide.
- C Pass the fuel hose through the hose guide.
- D Fasten the fuel hose.
- E To the engine
- F Position the hose clip tabs inward.
- G Position the hose clip tabs downward.

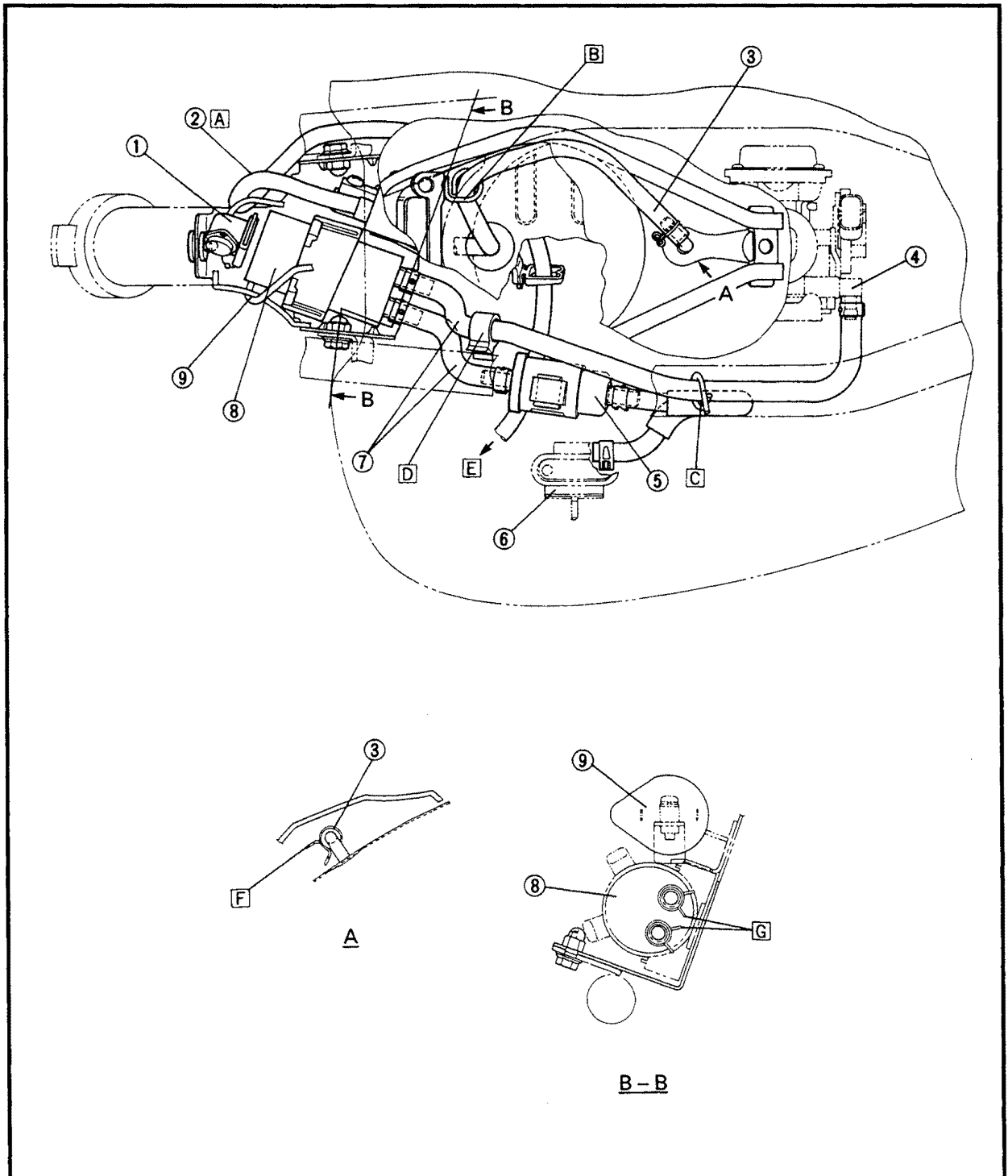



- ① Canister ass'y
- ② Bracket
- ③ Hose (Rollover valve - fuel tank)
- ④ Hose (Canister - carburetor)
- ⑤ Rollover valve assembly
- ⑥ Hose (Rollover valve - canister)
- ⑦ Hose (canister - atmosphere)

- A Position this under clamp, (Both ③ and ④)
- B Install clamp so that opening faces upward.
- C Install pipe with diagonal cut facing downward.
- D Install clip with knob pointing inward.
- E Install this so that opening faces outward.
- F Position this under clamp.
- G Place ③ in front of ④.

FOR CALIFORNIA

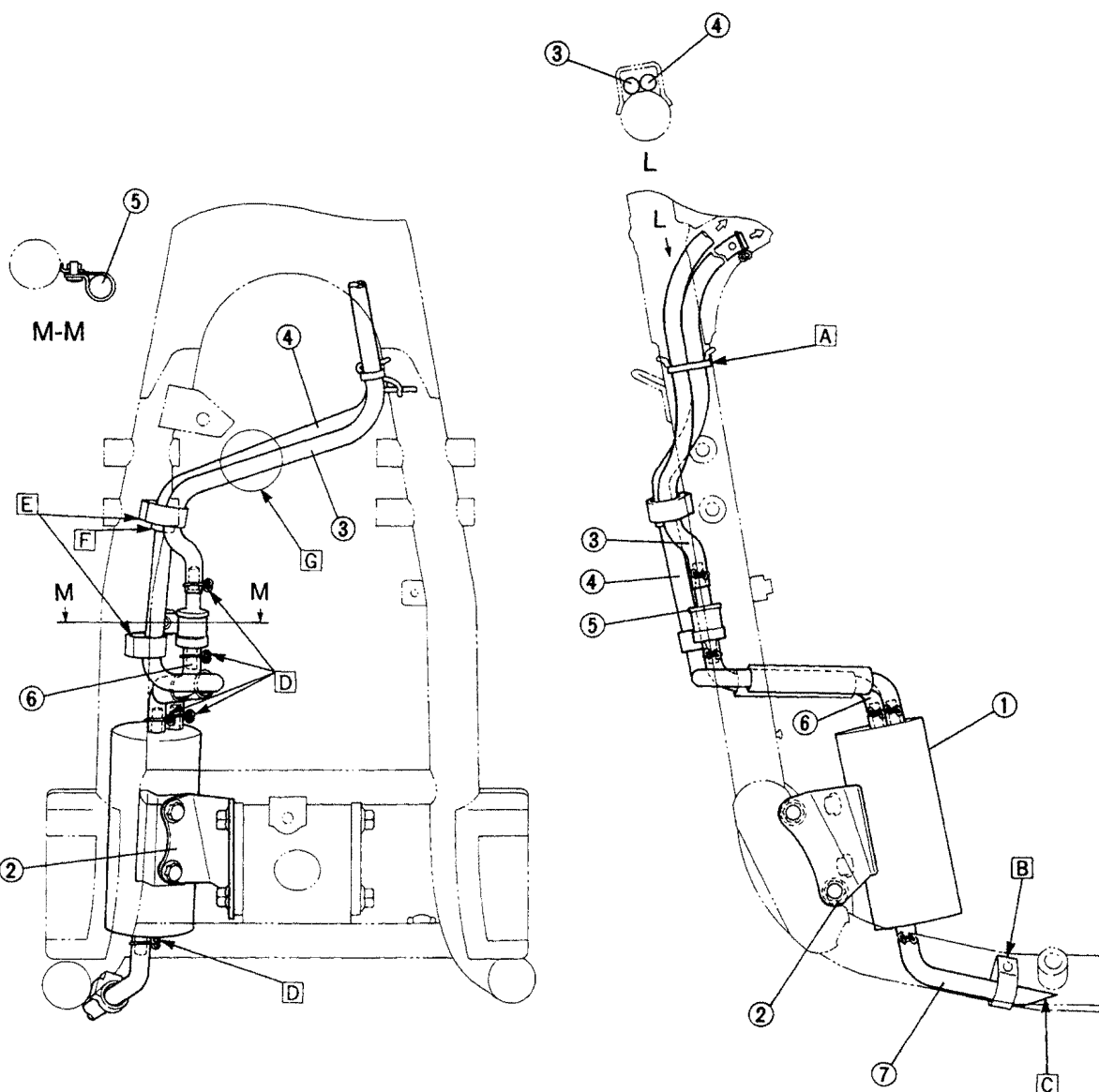

EB300000

PERIODIC INSPECTIONS AND ADJUSTMENTS

INTRODUCTION

This chapter includes all information necessary to perform recommended inspections and adjustments. These preventive maintenance procedures, if followed, will ensure more reliable vehicle operation and a longer service life. The need for costly overhaul work will be greatly reduced. This information applies to vehicles already in service as well as to new vehicles that are being prepared for sale. All service technicians should be familiar with this entire chapter.

EB301000

PERIODIC MAINTENANCE/LUBRICATION INTERVALS

ITEM	ROUTINE	INITIAL	ODOMETER READINGS					
		1,000 km (600 mi) or 1 month	7,000 km (4,400 mi) or 7 months	13,000 km (8,200 mi) or 13 months	19,000 km (12,000 mi) or 19 months	25,000 km (15,800 mi) or 25 months	31,000 km (19,600 mi) or 31 month	
1*	Valve clearance	Check and adjust valve clearance when engine is cold.	√	√	√	√	√	√
2	Spark plugs	Check condition. Adjust gap and clean. Replace at 13,000 km (or 13 months) and thereafter every 12,000 km (or 12 months).		√	Replace	√	Replace	√
3*	Crankcase ventilation system	Check ventilation hose for cracks or damage. Replace if necessary.		√	√	√	√	√
4*	Fuel line	Check fuel hose for cracks or damage. Replace if necessary.		√	√	√	√	√
5*	Exhaust system	Check for leakage. Retighten if necessary. Replace gasket(s) if necessary.		√	√	√	√	√
6*	Carburetor synchronization	Adjust synchronization of carburetors.	√	√	√	√	√	√
7*	Idle speed	Check and adjust engine idle speed. Adjust cable free play.		√	√	√	√	√
8*	Evaporative emission control system (For California only)	Check control system for damage. Replace if necessary.				√		√

Items marked with an asterisk (*) require special tools, data and technical skills for servicing. Take the motorcycle to a Yamaha Dealer or refer to the Service Manual when servicing these items.

3

GENERAL MAINTENANCE/LUBRICATION



GENERAL MAINTENANCE/LUBRICATION

ITEM	ROUTINE	INITIAL	ODOMETER READINGS					
		1,000 km (600 mi) or 1 month	7,000 km (4,400 mi) or 7 months	13,000 km (8,200 mi) or 13 months	19,000 km (12,000 mi) or 19 months	25,000 km (15,800 mi) or 25 months	31,000 km (19,600 mi) or 31 month	
1	Engine oil	Replace (Warm engine before draining). <See NOTE>	√	√	√	√	√	√
2	Engine oil filter	Replace at initial 1,000 km (600 mi) or 1 month, and thereafter every 12,000 km (7,600 mi) or 12 months.	√		√		√	
3*	Air filter	Clean or replace if necessary.		√	√	√	√	√
4	Clutch	Check operation. Adjust or replace cable.	√	√	√	√	√	√
5*	Front brake	Check operation, fluid level, and for fluid leakage. <See NOTE> Correct accordingly. Replace brake pads if necessary.	√	√	√	√	√	√
6*	Rear brake	Check operation. Adjust cable and replace brake shoes if necessary.	√	√	√	√	√	√
7	Final gear oil	Check oil level and oil leakage. Replace at initial 1,000 km (600 mi) or 1 month, and thereafter every 24,000 km (15,200 mi) or 12 months. #4	Replace	√	√	√	Replace	√
8*	Wheels	Check balance, runout, spoke tightness and for damage. Tighten spokes and rebalance or replace if necessary.		√	√	√	√	√
9*	Tires	Check tire tread wear and for damage. Replace if necessary.		√	√	√	√	√
10*	Wheel bearings	Check bearings for looseness or damage. Replace if necessary.		√	√	√	√	√
11*	Swing arm	Check swing arm pivot for play. Correct if necessary. Moderately repack every 24,000 km (15,200 mi) or 24 months. #2			√		√ Repack	
12*	Steering bearings	Check bearing play and steering for smooth operation. Correct if necessary. Moderately repack every 24,000 km (15,200 mi) or 24 months. #3	√		√		√ Repack	√
13*	Chassis fasteners	Check all nuts, bolts and screws for tightness. Tighten if necessary.	√	√	√	√	√	√
14	Sidestand	Check operation. Lubricate pivot and contact surfaces with chain lube lightly. Repair if necessary. #1	√	√	√	√	√	√
15*	Sidestand switch	Check operation. Replace if necessary.	√	√	√	√	√	√
16*	Front fork	Check operation and for oil leakage. Repair if necessary.		√	√	√	√	√
17*	Rear shock absorber	Check operation and for oil leakage. Replace if necessary.		√	√	√	√	√
18*	Control and meter cable	Apply chain lube thoroughly. #1	√	√	√	√	√	√
19	Brake/Clutch lever pivot shaft	Apply chain lube lightly. #1		√	√	√	√	√
20	Brake pedal and shift pedal shaft	Apply chain lube lightly #1		√	√	√	√	√

Items marked with an asterisk (*) require special tools, data and technical skills for servicing. Take the motorcycle to a Yamaha Dealer or refer to the Service Manual when servicing these items.



- #1 : Yamaha chain and cable lube or SAE10W30 motor oil.
- #2 : Molybdenum disulfide grease.
- #3 : Lithium soap base grease.
- #4 : SAE80 API "GL-4" hypoid gear oil.

NOTE:

- The air filter needs more frequent service if you are riding in unusually wet or dusty areas.
- For odometer readings or time periods higher than 31,000 km (19,600 mi) or 31 months repeat the same maintenance as listed in the table from the 7,000 km (4,400 mi) or 7 months every 6,000 km (3,800 mi) or 6 month interval.
- Brake fluid replacement:
 1. When disassembling the master cylinder or caliper cylinder, replace the brake fluid. Normally check the brake fluid level and add fluid as required.
 2. On the inner parts of the master cylinder and caliper cylinder, replace the oil seals every two years.
 3. Replace the brake hoses every four years, or if cracked or damaged.
- Engine oil type:
 - Yamalube 4 (20W40) or SAE 20W40 type "SE" motor oil for temperatures 5°C (40°F) or above.
 - Yamalube 4 (10W30) or SAE 10W30 type "SE" motor oil for temperatures 15°C (60°F) or below.

FUEL TANK AND SEATS

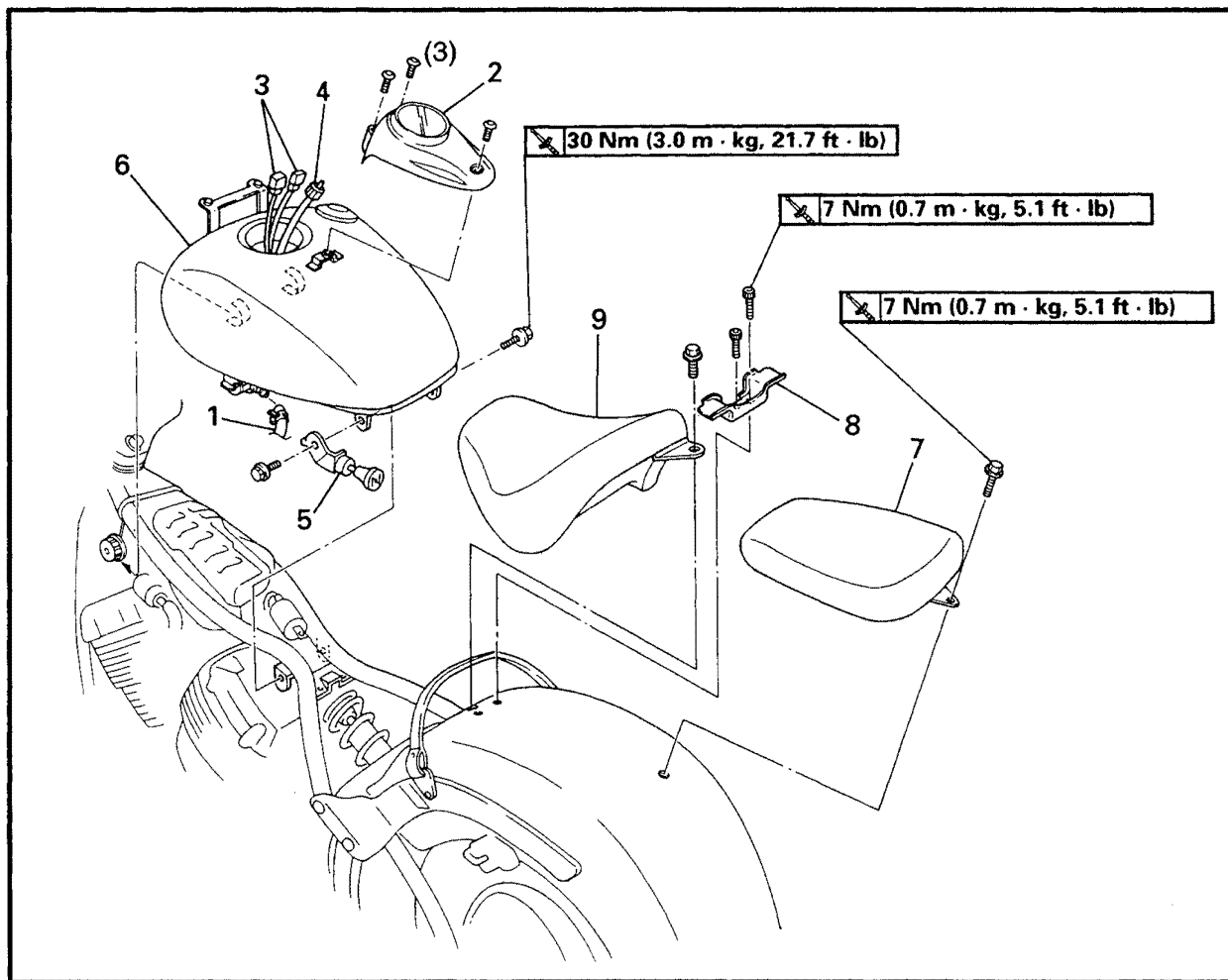

Order	Job name/Part name	Q'ty	Remarks
	Fuel tank and seats removal		
1	Fuel hose	1	Remove the parts in the order below. NOTE: _____ Set the fuel cock to "OFF" before disconnecting the fuel hose.
2	Meter assembly	1	
3	Meter lead coupler	2	
4	Speedometer cable	1	NOTE: _____ Disconnect the speedometer cable from the front wheel side first.
5	Starter knob bracket	1	
6	Fuel tank assembly	1	
7	Passenger seat	1	
8	Seat bracket	1	
9	Rider's seat	1	
			For installation, reverse the removal procedure.

EB303003

ENGINE

VALVE CLEARANCE ADJUSTMENT

NOTE:

- Valve clearance adjustment should be made with the engine cool, at room temperature.
- When the valve clearance is to be measured or adjusted, the piston must be at Top Dead Center (T.D.C.) on the compression stroke.

1.Remove:

- Meter assembly
- Fuel tank
Refer to "FUELTANK AND SEATS".

2.Remove:

- Carburetor assembly
Refer to "CARBURETOR" in CHAPTER 5.

3.Disconnect:

- Spark plug caps

4.Remove:

- Spark plugs

5.Remove:

- Ignition coil ①

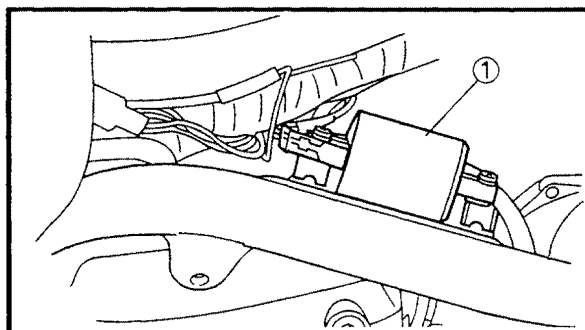

6.Remove:

- Cylinder head covers
Refer to "ENGINE REMOVAL".
- Cylinder head cover brackets
Refer to "CYLINDER HEADS".

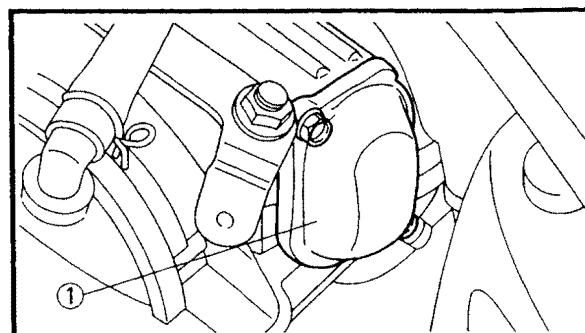

7.Remove:

- Tappet covers ①

VALVE CLEARANCE ADJUSTMENT

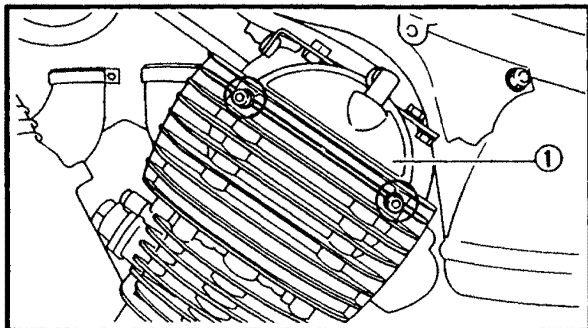

- 8.Remove:
- Camshaft sprocket covers ①

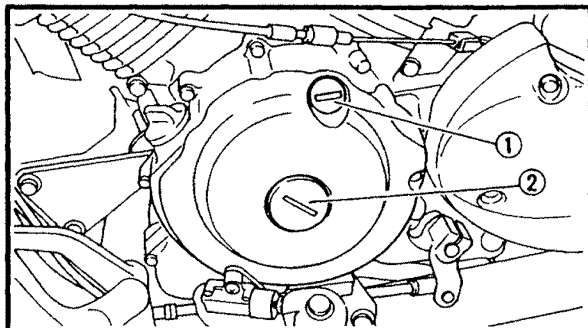

- 9.Remove:
- Timing plug ①
 - Straight plug ②

- 10.Measure:
- Valve clearance
Out of specification → Adjust.

	Valve clearance (cold):
	Intake valve: 0.07 ~ 0.12mm (0.003 ~ 0.005 in)
	Exhaust valve: 0.12 ~ 0.17 mm (0.005 ~ 0.007 in)

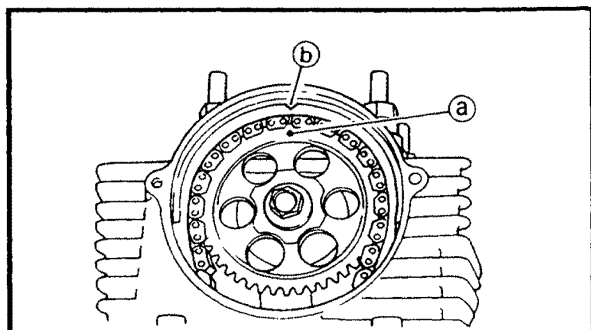

- Measuring steps:**
- Turn the crankshaft clockwise with a wrench.
 - Align the camshaft sprocket mark ① with the stationary pointer ② on the cylinder head. When the mark is aligned with the pointer, the piston is at Top Dead Center (TDC).

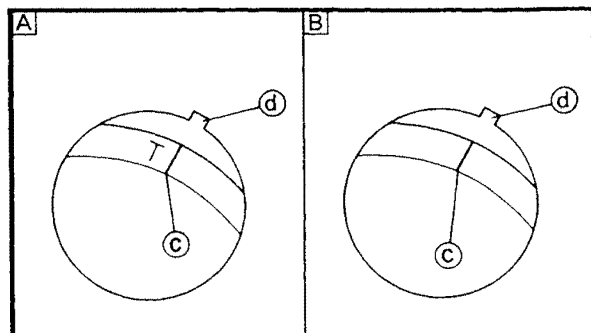

- Check the front/rear cylinder timing mark ③ on the rotor. If necessary, turn the crankshaft to align the timing mark with the pointer ④ on the AC magneto cover.
- A For rear cylinder ("TI" mark)
 B For front cylinder ("I" mark)

VALVE CLEARANCE ADJUSTMENT

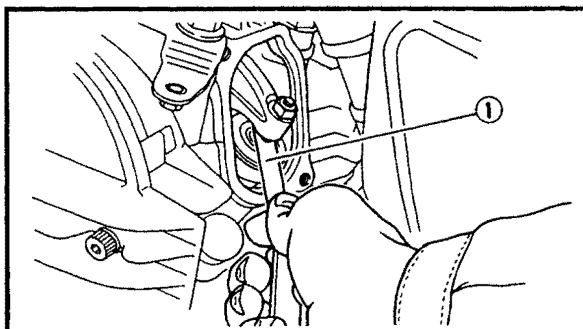

- Measure the valve clearance using a thickness gauge ①.

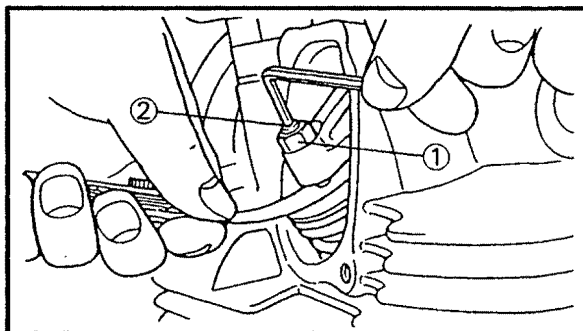

- 11.Adjust:
- Valve clearance

Adjustment steps:

- Loosen the locknut ①.
- Insert a thickness gauge between the adjuster end and the valve end.
- Turn the adjuster ② in or out until the specified clearance is obtained.

Turning in:	valve clearance is decreased.
Turning out:	valve clearance is increased.

- Hold the adjuster to prevent it from moving and tighten the locknut.

	Locknut: 14 Nm (1.4 m · kg, 10 ft · lb)
--	---

- Measure the valve clearance again.
- If the clearance is still incorrect, repeat all the clearance adjustment steps until the specified clearance is obtained.

- 12.Install:
- All removed parts

NOTE: _____
Install all removed parts in the reverse order of their disassembly. Note the following points.

VALVE CLEARANCE ADJUSTMENT/ CARBURETOR SYNCHRONIZATION



13. Install:

- Camshaft sprocket covers

10 Nm (1.0 m · kg, 7.2 ft · lb)

- Tappet covers

10 Nm (1.0 m · kg, 7.2 ft · lb)

- Cylinder head cover

10 Nm (1.0 m · kg, 7.2 ft · lb)

- Spark plugs

18 Nm (1.8 m · kg, 13 ft · lb)

EB303010

CARBURETOR SYNCHRONIZATION

NOTE:

Prior to synchronizing the carburetors, the valve clearance should be properly adjusted and the ignition timing should be checked.

1. Stand the motorcycle on a level surface.

NOTE:

Place the motorcycle on a suitable stand.

2. Remove:

- Vacuum plugs ①

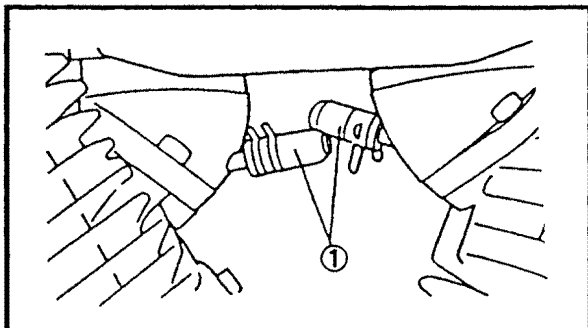

3. Attach:

- Vacuum gauge ①
- Engine tachometer ②
(to the #1 spark plug lead)

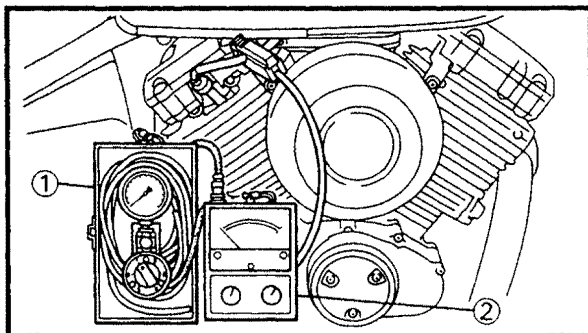

Vacuum gauge:
YU-08030-A, 90890-03094
Engine tachometer:
YU-08036-A, 90890-03113

4. Start the engine and let it warm up for several minutes.

5. Check:

- Engine idling speed
Out of specification → Adjust.
Refer to "IDLING SPEED ADJUSTMENT".



Engine idling speed:
1,150 ~ 1,250 r/min

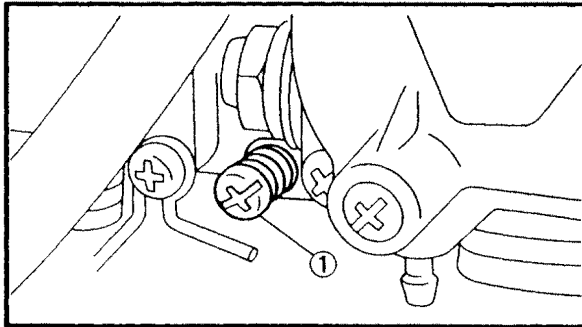

6.Adjust:

- Carburetor synchronization

Adjustment steps:

- Synchronize carburetor #1 to carburetor #2 by turning the synchronizing screw ① until both gauges read the same.
- Rev the engine two or three times, each time for less than a second, and check the synchronization again.

Vacuum pressure at idle speed:
29.0 kPa (220 mm Hg, 8.7 in Hg)

NOTE: _____

The difference between the two carburetors should not exceed 1.33 kPa (10 mm Hg, 0.39 in Hg).

7.Check:

- Engine idling speed
Out of specification → Adjust.

8.Stop the engine and detach the measuring equipment.

9.Adjust:

- Throttle cable free play
Refer to "THROTTLE CABLE ADJUSTMENT".



Free play (throttle cable):
4 ~ 6 mm (0.16 ~ 0.24 in)
At throttle grip flange

10.Install:

- Vacuum plugs

EB303021

IDLING SPEED ADJUSTMENT

NOTE:

Prior to adjusting the idling speed, the carburetor synchronization should be adjusted properly, the air filter should be clean and the engine should have adequate compression.

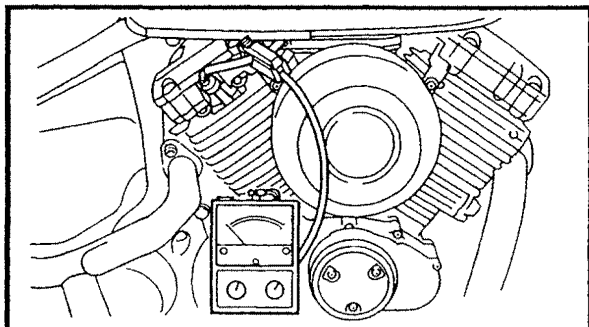

1. Start the engine and let it warm up for several minutes.

2. Attach:

- Engine tachometer
(to the #1 spark plug lead)



Engine tachometer:
YU-08036-A, 90890-03113

3. Check:

- Engine idling speed
Out of specification → Adjust.



Engine idling speed:
1,150 ~ 1,250 r/min

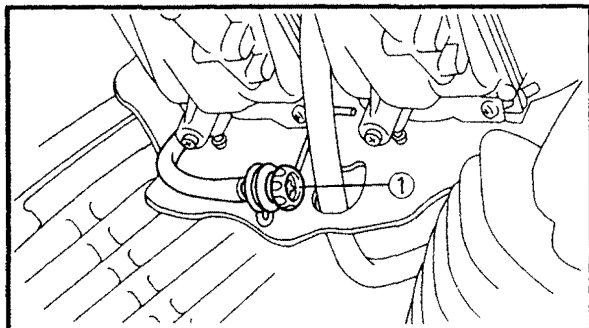

4. Adjust:

- Engine idling speed

Adjustment steps:

- Turn the throttle stop screw ① in or out until the specified idling speed is obtained.

Turning in:	idling speed is increased.
Turning out:	idling speed is decreased.

IDLING SPEED ADJUSTMENT/ THROTTLE CABLE ADJUSTMENT



5.Adjust:

- Throttle cable free play
Refer to "THROTTLE CABLE ADJUSTMENT".



Free play (throttle cable):
4 ~ 6 mm (0.16 ~ 0.24 in)
At throttle grip flange

EB303030

THROTTLE CABLE ADJUSTMENT

NOTE:

Prior to adjusting the throttle cable free play, the engine idling speed and carburetor synchronization should be adjusted properly.

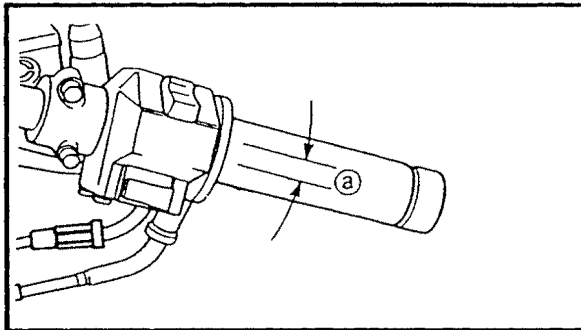

1.Check:

- Throttle cable free play ①
Out of specification → Adjust.



Free play (throttle cable):
4 ~ 6 mm (0.16 ~ 0.24 in)
At throttle grip flange

2.Remove:

- Rider's seat
- Fuel tank
Refer to "FUEL TANK AND SEATS".

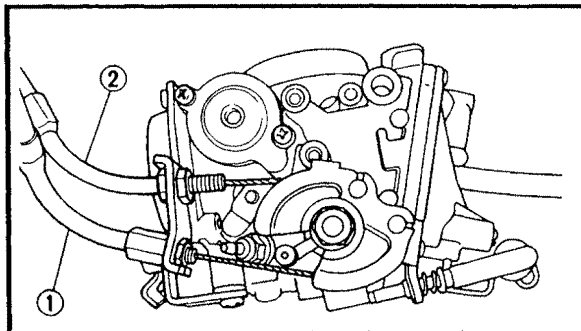

3.Adjust:

- Throttle cable free play

Adjustment steps:

NOTE:

When the motorcycle is accelerating, throttle cable #1 ① is pulled and throttle cable #2 ② is pushed.

THROTTLE CABLE ADJUSTMENT/ SPARK PLUG INSPECTION

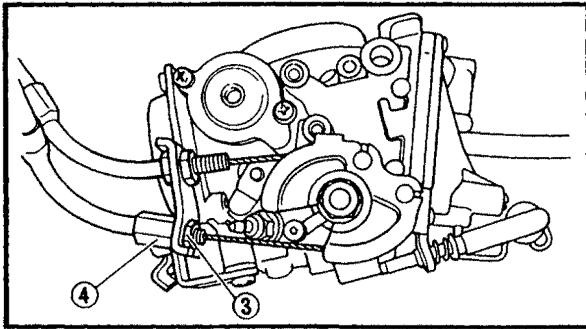

1st step:

- Loosen the locknut ③ on throttle cable #1.
- Turn the adjuster ④ in or out until the specified free play is obtained.

Turning in:	free play is increased.
Turning out:	free play is decreased.

- Tighten the locknuts.

NOTE:

If the specified free play cannot be obtained on the carburetor end of the cable, use the adjuster on the handlebar end.

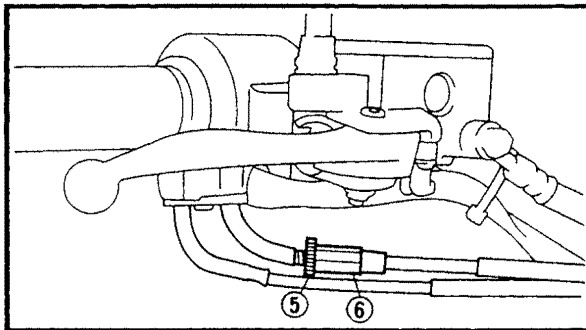

Additional step:

- Loosen the locknut ⑤.
- Turn the adjuster ⑥ in or out until the specified free play is obtained.

Turning in:	free play is increased.
Turning out:	free play is decreased.

- Tighten the locknut.

⚠ WARNING

After adjusting, turn the handlebars to the right and to the left to ensure that this does not cause the engine idling speed to change.

4.Install:

- Fuel tank
 - Rider's seat
- Refer to "FUEL TANK AND SEATS".

EB303040

SPARK PLUG INSPECTION

1.Remove:

- Spark plug caps
- Spark plugs

CAUTION:

Before removing the spark plugs, use compressed air to blow away any dirt accumulated in the spark plug wells, to prevent it from falling into the cylinders.

2. Check:

- Spark plug type
Incorrect → Replace.

Standard spark plug:
DPR7EA-9 (NGK)
X22EPR-U9 (DENSO)

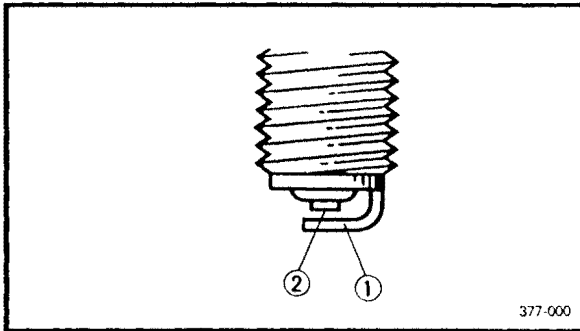

3. Inspect:

- Electrode ①
Wear/damage → Replace.
- Insulator ②
Abnormal color → Replace.
Normal color is a medium-to-light tan color.

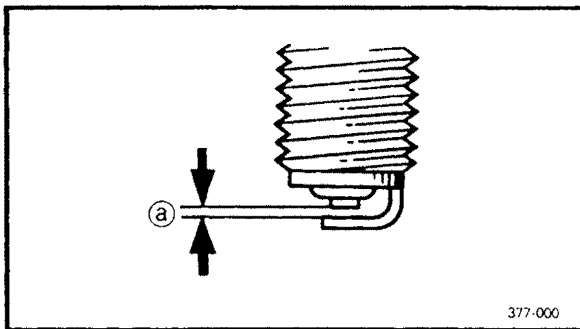

4. Clean:

- Spark plug
(with spark plug cleaner or wire brush)

5. Measure:

- Spark plug gap ③
(with a wire gauge)
Out of specification → Adjust gap.

 **Spark plug gap:**
0.8 ~ 0.9 mm (0.031 ~ 0.035 in)

6. Install:

- Spark plug  **18 Nm (1.8 m · kg, 13 ft · lb)**

NOTE:

Before installing a spark plug, clean the gasket surface and the plug surface.

EB303051

IGNITION TIMING CHECK

NOTE:

Prior to checking the ignition timing, check all electrical connections related to the ignition system. Make sure all connections are tight and free of corrosion and that all ground connections are tight.

IGNITION TIMING CHECK

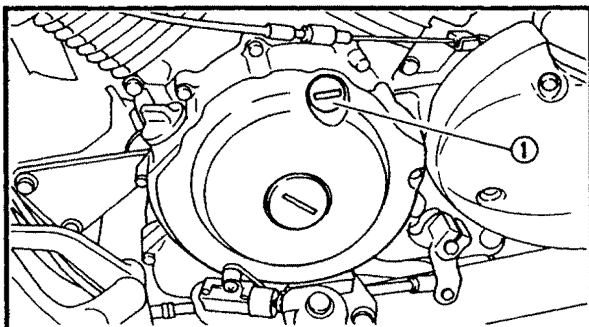

- 1.Remove:
- Timing plug ①

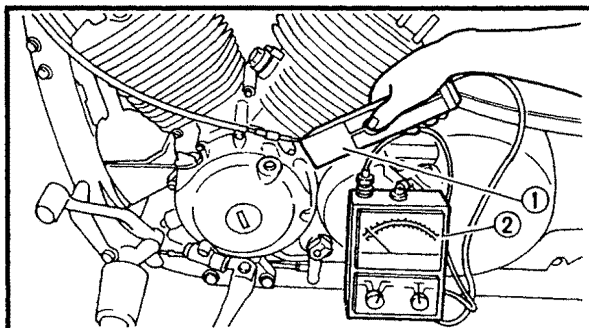

- 2.Attach:
- Timing light ①
 - Engine tachometer ②
(to the #1 spark plug lead)

	<p>Timing light: YU-33277-A, 90890-03141</p> <p>Engine tachometer: YU-08036-A, 90890-03113</p>
---	--

- 3.Check:
- Ignition timing

Checking steps:

- Start the engine and let it warm up for several minutes. Let the engine run at the specified speed.

	<p>Engine idling speed: 1,150 ~ 1,250 r/min</p>
---	--

- Check that the stationary pointer ① is within the firing range ② on the rotor. Incorrect firing range → Check the ignition system.

NOTE: _____
Ignition timing is not adjustable.

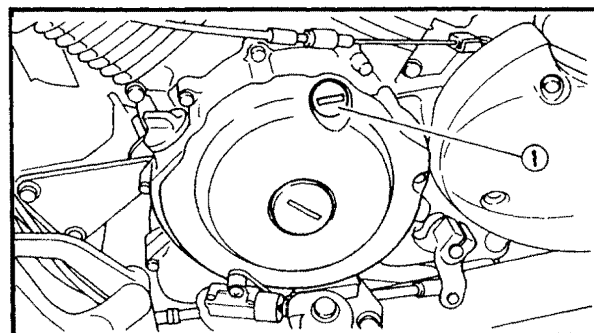
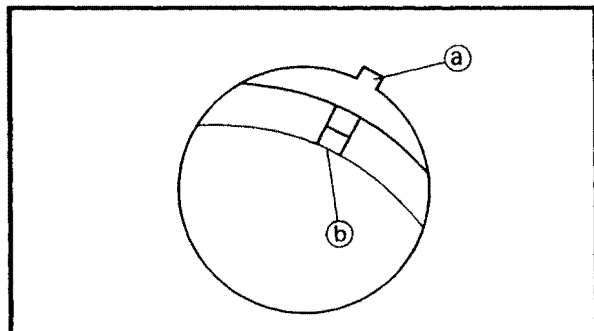

- 4.Install:
- Timing plug ①

EB303060

COMPRESSION PRESSURE MEASUREMENT

NOTE: Insufficient compression pressure will result in a loss of performance.

1. Check:

- Valve clearance
Out of specification → Adjust.
Refer to "VALVE CLEARANCE ADJUSTMENT".

2. Start the engine and let it warm up for several minutes.

3. Stop the engine.

4. Remove:

- Spark plug caps
- Spark plugs

CAUTION:

Before removing the spark plugs, use compressed air to blow away any dirt accumulated in the spark plug wells, to prevent it from falling into the cylinders.

5. Attach:

- Compression gauge ①

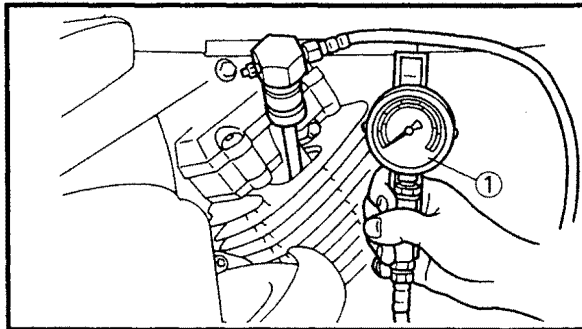

**Compression gauge set:
YU-33223, 90890-03081**

6. Measure:

- Compression pressure
If it exceeds the maximum pressure allowed → Inspect the cylinder head, valve surfaces and piston crown for carbon deposits.
If it is below the minimum pressure → Squirt a few drops of oil into the affected cylinder and measure again.
- Refer to the table below.

Compression pressure (with oil applied in the cylinder)	
Reading	Diagnosis
Higher than without oil	Worn or damaged pistons → Repair.
Same as without oil	Possible defective ring(s), valves, cylinder head gasket or piston → Repair.

	Compression pressure (at sea level)
	Standard:
	1,100 kPa (11 kg/cm ² , 156.4 psi)
	Minimum:
	1,000 kPa (10 kg/cm ² , 142.2 psi)
	Maximum:
	1,200 kPa (12 kg/cm ² , 170.6 psi)

Measurement steps:

- Crank the engine with the throttle wide open until the reading on the compression gauge stabilizes.

⚠ WARNING

To prevent sparking, ground all spark plug leads before cranking the engine.

- Repeat the previous steps for the other cylinders.

NOTE:

The difference in compression pressure between the highest and lowest cylinder compression readings should not exceed 100 kPa (1 kg/cm², 1 psi).

7. Install:

- Spark plugs  18 Nm (1.8 m · kg, 13 ft · lb)
- Spark plug caps

ENGINE OIL LEVEL INSPECTION

1. Stand the motorcycle on a level surface.

NOTE:

- Make sure the motorcycle is upright when inspecting the oil level.
- Place the motorcycle on a suitable stand.

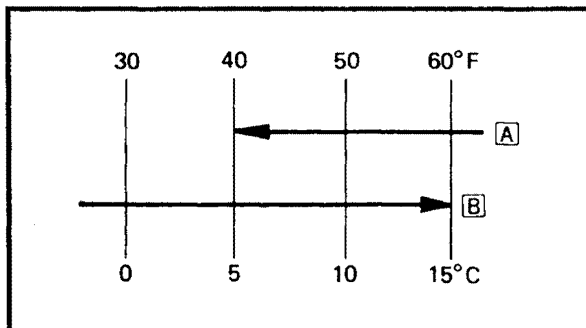
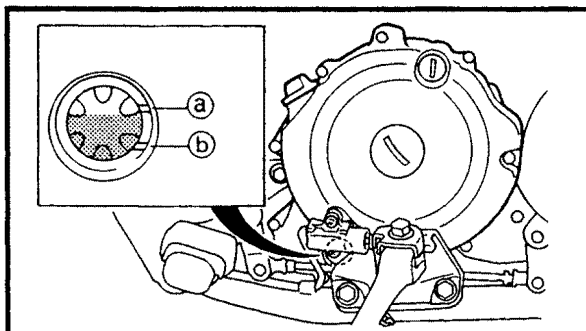

2. Inspect:

- Oil level
Oil level should be between the maximum ① and minimum ② marks.
Oil level is below the minimum mark → Add oil up to the proper level.



Recommended oil:

At 5°C (40°F) or higher [A]:

Yamalube 4 (20W40) or SAE 20W40 type SE motor oil

At 15°C (60°F) or lower [B]:

Yamalube 4 (10W30) or SAE 10W30 type SE motor oil

CAUTION:

- Do not add any chemical additives. Engine oil also lubricates the clutch and additives could cause clutch slippage.
- Do not allow foreign material to enter the crankcase.

NOTE:

Recommended engine oil classification; API Service "SE", "SF" type or equivalent (e.g. "SF-SE", "SF-SE-CC", "SF-SE-SD" etc.).

3. Start the engine and let it warm up for several minutes.

4. Turn off the engine and inspect the oil level again.

NOTE:

Before inspecting the oil level, wait a few minutes until the oil has settled.

ENGINE OIL REPLACEMENT

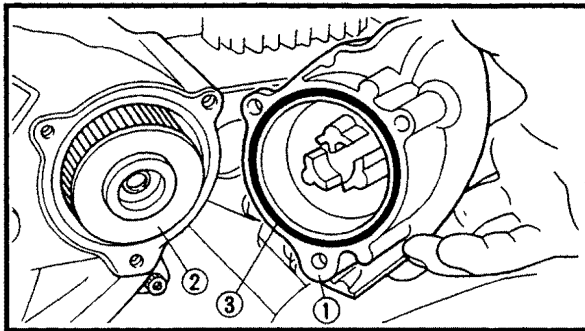
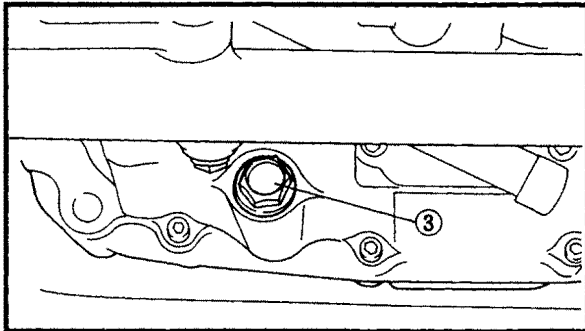
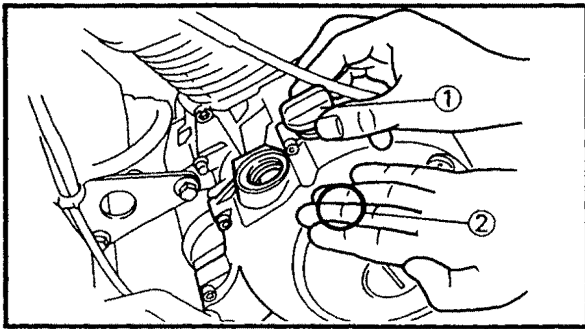

EB303080

ENGINE OIL REPLACEMENT

1. Start the engine and let it warm up for several minutes.
2. Turn off the engine and place a container under the drain bolt.
3. Remove:
 - Oil filler plug ①
 - O-ring ②
 - Drain bolt ③
 - GasketDrain the crankcase of its oil.

4. If the oil filter is to be replaced during this procedure, remove the following parts and reinstall them afterwards.

Replacement steps:

- Remove the oil filter element cover ① and oil filter element ②.
- Check the O-ring ③. If cracked or damaged, replace them with new one.
- Install the oil filter element and oil filter element cover.



Oil filter cover:
10 Nm (1.0 m · kg, 7.2 ft · lb)

5. Install:

- Gasket **New**
- Drain bolt  **43 Nm (4.3 m · kg, 31 ft · lb)**

NOTE:

Inspect the drain bolt gasket. If it is damaged, replace it.

6.Fill:

- Crankcase
Refer to "ENGINE OIL LEVEL INSPECTION".

	Oil quantity: Total amount: 3.2 L (2.8 Imp qt, 3.4 US qt) Periodic oil change: 2.6 L (2.3 Imp qt, 2.7 US qt) With oil filter replacement: 2.8 L (2.6 Imp qt, 3.0 US qt)
--	---

7.Install:

- Oil filler plug
- Warm up the engine for a few minutes, then turn it off.

8.Check:

- Engine (for oil leaks)
- Oil level

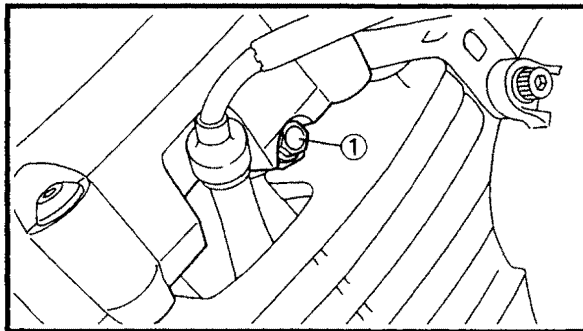

9.Check:

- Oil pressure

Checking steps:

- Slightly loosen the oil gallery bolt ①.
- Start the engine and keep it idling until oil starts to seep from the oil gallery bolt. If no oil comes out after one minute, turn the engine off so that it will not seize.
- Check the oil passages, oil filter and oil pump for damage or leakage. Refer to "INSPECTION AND REPAIR" in CHAPTER 4.
- Start the engine after solving the problem(s) and check the oil pressure again.
- Tighten the oil gallery bolt to specification.

	Oil gallery bolt: 8 Nm (0.8 m · kg, 5.8 ft · lb)
--	--

CLUTCH ADJUSTMENT/AIR FILTER CLEANING

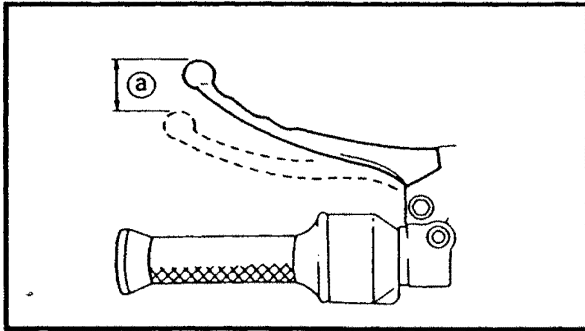

EB303090

CLUTCH ADJUSTMENT

1. Check:

- Clutch cable free play **a**
Out of specification → Adjust.



Free play (clutch cable):
10 ~15 mm (0.4 ~ 0.6 in)
At clutch lever end

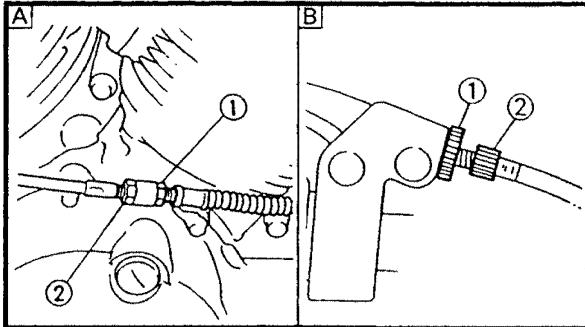

2. Adjust:

- Clutch cable free play

Adjustment steps:

- Loosen the locknuts **1**.
- Turn the adjusters **2** in or out until the specified free play is obtained.

Turning in:	free play is increased.
Turning out:	free play is decreased.

- Tighten the locknuts.

A Handlebar end

B Engine end

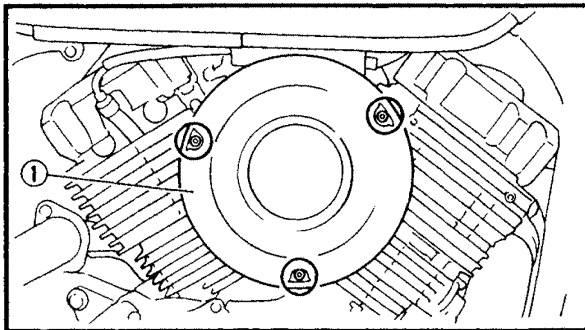

EB303120

AIR FILTER CLEANING

1. Remove:

- Air filter case cover **1**

2. Remove:

- Air filter element **2**

CAUTION:

Never operate the engine without the air filter element installed. Unfiltered air will cause rapid wear of engine parts and may damage the engine. Operating the engine without the filter element will also affect the carburetor tuning, leading to poor engine performance and possible overheating.

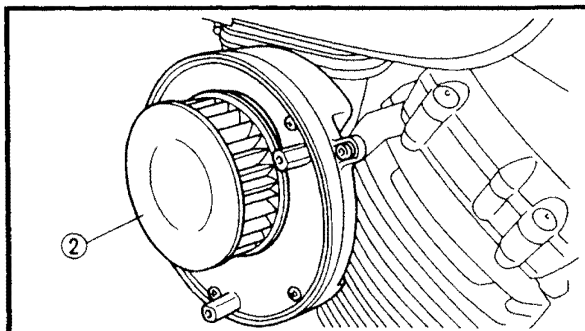

AIR FILTER CLEANING/CARBURETOR JOINT INSPECTION/FUEL LINE INSPECTION

INSP
ADJ

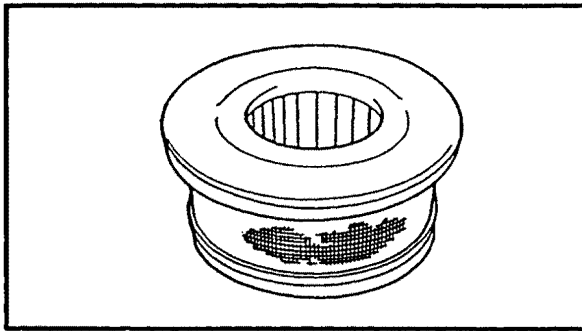

3. Inspect:

- Air filter element
Damage → Replace.

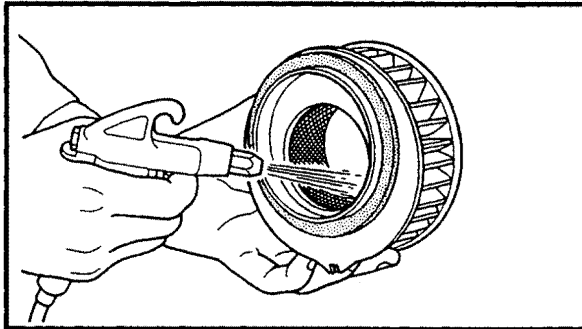

4. Clean:

- Air filter element
Blow off the dust from the outside of the element using compressed air.

5. Install:

- Air filter element
- Air filter case cover

NOTE:

When installing the element in its case, make sure its sealing surface matches the sealing surface of the filter case so that no air can leak out.

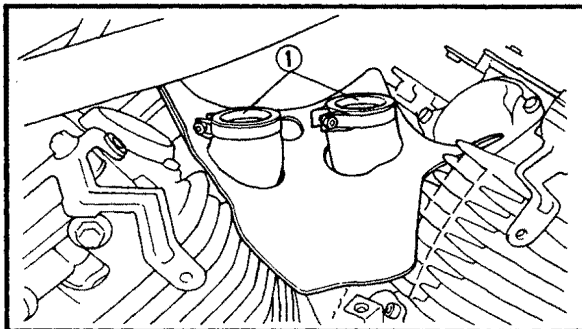

EB303130

CARBURETOR JOINT INSPECTION

1. Inspect:

- Carburetor joints ①
Cracks/damage → Replace.
Refer to "CARBURETOR" in CHAPTER 5.

EB303140

FUEL LINE INSPECTION

1. Inspect:

- Fuel hose
Cracks/damage → Replace.
- Fuel filter
Contamination/damage → Replace.

BREATHER HOSE INSPECTION/ EXHAUST SYSTEM INSPECTION

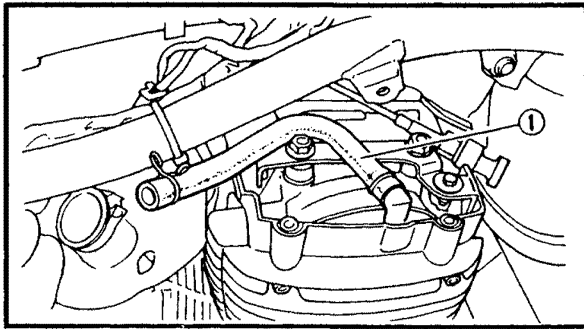

BREATHER HOSE INSPECTION

1.Remove:

- Cylinder head cover (rear cylinder)
Refer to "ENGINE REMOVAL" in CHAPTER 4.

2.Inspection:

- Breather hose ①
Cracks/damage → Replace.
Loose connection → Connect properly.

CAUTION:

Make sure that the crankcase breather hose is routed correctly.

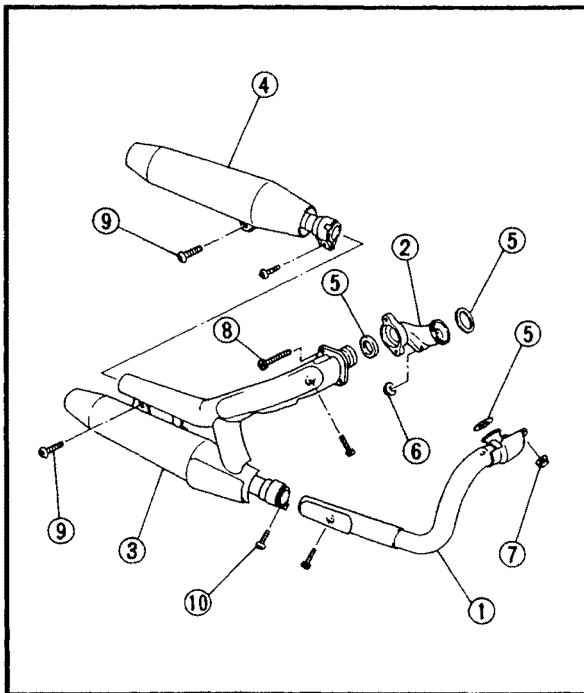

EB303160

EXHAUST SYSTEM INSPECTION

1.Inspect:

- Exhaust pipe (front) ①
- Exhaust pipe joint (rear) ②
- Muffler assembly (lower) ③
- Muffler assembly (upper) ④
Cracks/damage → Replace.
- Gaskets ⑤
Exhaust gas leaks → Replace.

2.Check:

- Nut ⑥
- Nut ⑦
- Bolt ⑧
- Bolts ⑨
- Screws ⑩

	20 Nm (2.0 m · kg, 14.4 ft · lb)
	25 Nm (2.5 m · kg, 18 ft · lb)
	20 Nm (2.0 m · kg, 14.4 ft · lb)
	25 Nm (2.5 m · kg, 18 ft · lb)
	20 Nm (2.0 m · kg, 14.4 ft · lb)

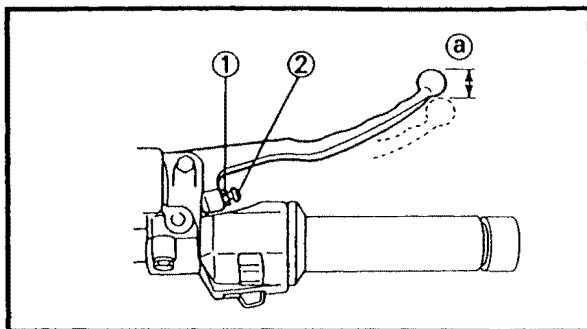

EB304002

CHASSIS

FRONT BRAKE ADJUSTMENT

1. Check:

- Brake lever free play ①
- Out of specification → Adjust.

	<p>Free play (brake lever): 10 ~ 15 mm (0.4 ~ 0.6 in) (at brake lever end)</p>
--	---

2. Adjust:

- Brake lever free play

Adjustment steps:

- Loosen the locknut ①.
- Turn the adjuster ② in or out until the specified free play is obtained.

Turning in:	brake lever free play is decreased.
Turning out:	brake lever free play is increased.

- Tighten the locknut.

CAUTION

After adjusting the front brake lever free play, make sure that there is no brake drag.

WARNING

A soft or spongy feeling in the brake lever can indicate the presence of air in the brake system. This air must be removed by bleeding the brake system before the motorcycle is operated. Air in the brake system will considerably reduce braking performance and could result in a loss of control and possibly an accident. Inspect and if necessary, bleed the brake system.

REAR BRAKE ADJUSTMENT

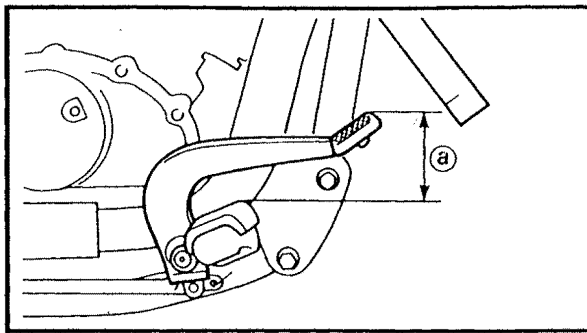

EB304012

REAR BRAKE ADJUSTMENT

1. Check:

- Brake pedal height ①
Out of specification → Adjust.

	Brake pedal height: 85 mm (3.3 in) (above the top of the footrest)
--	---

2. Adjust:

- Brake pedal height

Adjustment steps:

- Loosen the locknut ①.
- Turn the adjuster ② in or out until the specified pedal height is obtained.

Turning in:	brake pedal height is decreased.
Turning out:	brake pedal height is increased.

- Tighten the locknut.

	Locknut: 7 Nm (0.7 m · kg, 5.1 ft · lb)
--	---

3. Check:

- Brake pedal free play ①
Out of specification → Adjust.

	Free play (brake pedal): 20 ~ 30 mm (0.79 ~ 1.18 in)
--	--

4. Adjust:

- Brake pedal free play

Adjustment steps:

- Turn the adjuster ① in or out until the specified free play is obtained.

Turning in:	brake pedal free play is decreased.
Turning out:	brake pedal free play is increased.

CAUTION:

Make sure that there is no brake drag after adjusting the brake pedal height and the free play.

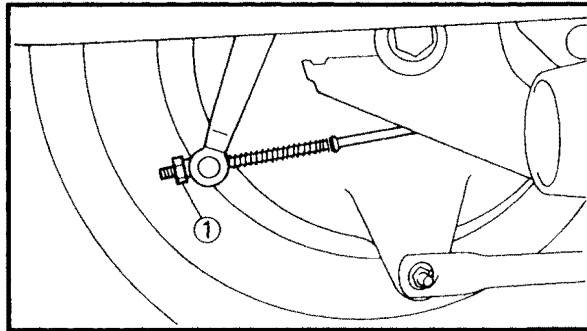
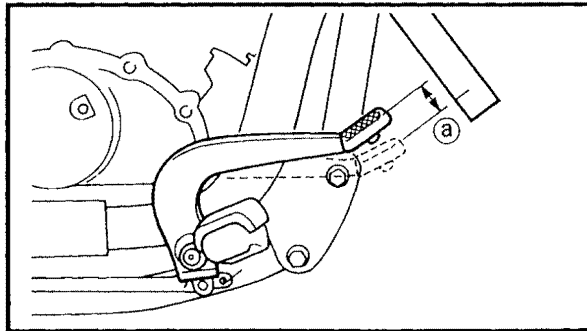
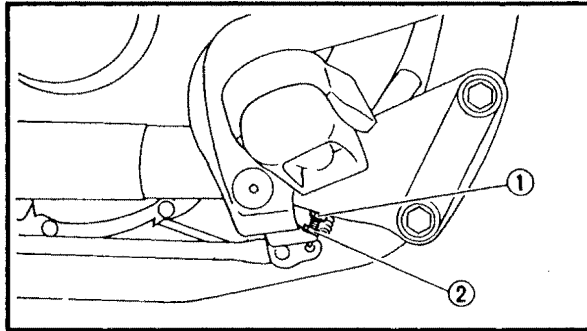

5.Adjust:

- Brake light switch

Refer to "BRAKE LIGHT SWITCH
ADJUSTMENT".

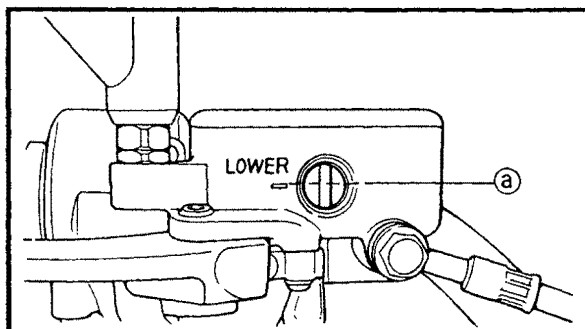

EB304020

BRAKE FLUID LEVEL INSPECTION

1.Stand the motorcycle on a level surface.

NOTE:

- When inspecting the brake fluid level, make sure the motorcycle is upright.
- Place the motorcycle on a suitable stand.

2.Inspect:

- Brake fluid level
Brake fluid level is below the "LOWER"
level line @ → Fill to proper level.



**Recommended brake fluid:
DOT 4**

NOTE:

For a correct reading of the brake fluid
level, make sure the top of the handlebar
brake fluid reservoir is horizontal.

CAUTION:

Brake fluid may corrode painted surfaces
or plastic parts. Always clean up any spilt
fluid immediately.

⚠ WARNING

- Use only the designated brake fluid. Other fluids may deteriorate the rubber seals, causing leakage and poor brake performance.
- Refill with the same type of fluid. Mixing fluids may result in a harmful chemical reaction leading to poor brake performance.
- When refilling, be careful that water does not enter the brake fluid reservoir. Water will significantly lower the boiling point of the fluid and may cause vapor lock.

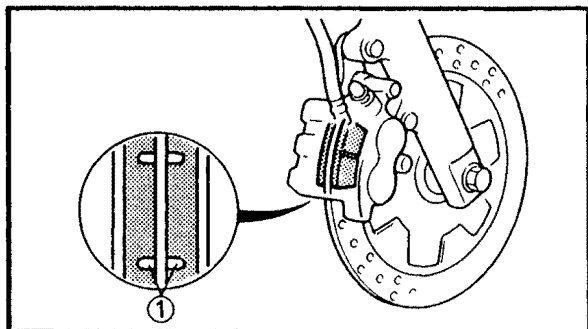

EB304030
BRAKE PAD INSPECTION

1. Operate the brake lever.
2. Inspect:
 - Brake pad
Wear indicators ① almost touch the brake disc → Replace the brake pads as a set.
Refer to "REAR WHEEL AND REAR BRAKE" in CHAPTER 6.

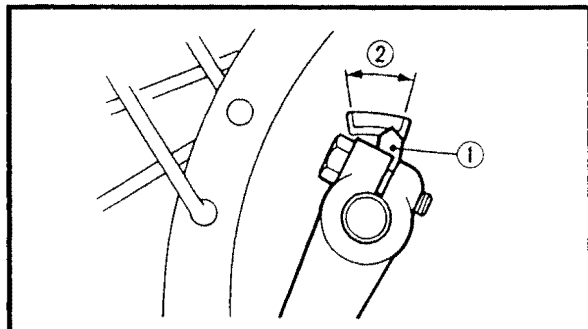

EB304040
BRAKE SHOE INSPECTION

1. Operate the brake pedal.
2. Inspect:
 - Brake shoes
Wear indicator ① reaches the wear limit line ② → Replace the brake shoes as a set.
Refer to "REAR WHEEL AND REAR BRAKE" in CHAPTER 6.

EB304050
BRAKE LIGHT SWITCH ADJUSTMENT

NOTE: _____
The brake light switch is operated by movement of the brake pedal.
Adjustment is correct when the brake light comes on just before the braking effect starts.

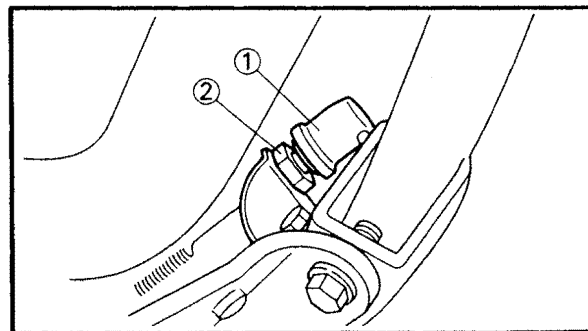

1. Check:
 - Brake light operation timing
Incorrect → Adjust.
2. Adjust:
 - Brake light operation timing

Adjustment steps:
• Hold the main body ① of the switch so that it does not rotate, and turn the adjuster ② in or out until the proper operation timing is obtained.

Turning in:	brake light comes on later.
Turning out:	brake light comes on sooner.

BRAKE HOSE INSPECTION AIR BLEEDING (HYDRAULIC BRAKE SYSTEM)

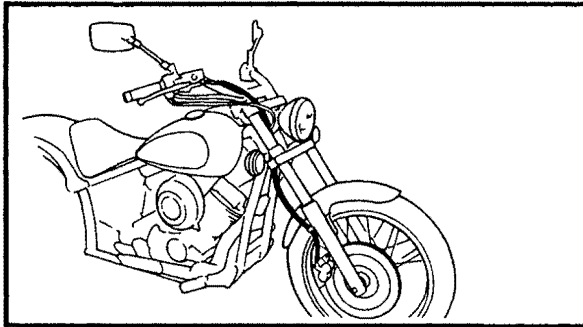

EB304060

BRAKE HOSE INSPECTION

1. Inspect:
 - Brake hose(s)
Cracks/wear/damage → Replace.
2. Check:
 - Brake hose clamp(s)
Loose → Tighten.
3. Hold the motorcycle upright and apply the front or rear brake.
4. Check:
 - Brake hose(s)
Activate the brake lever several times.
Brake fluid leakage → Replace the faulty hose.
Refer to "FRONT BRAKE" in CHAPTER 6.

EB304070

AIR BLEEDING (HYDRAULIC BRAKE SYSTEM)

⚠ WARNING

Bleed the brake system whenever:

- the system is disassembled
- a brake hose is loosened or removed
- the brake fluid level is very low
- brake operation is faulty

If the brake system is not properly bled, a loss of braking performance may occur.

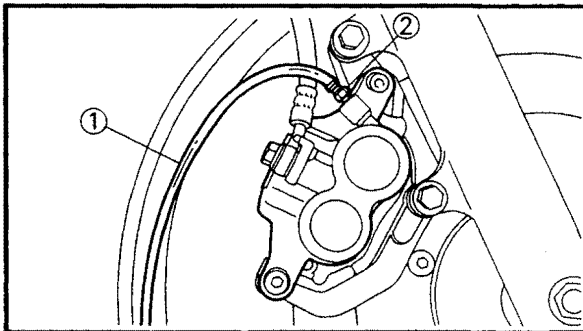

1. Bleed:

- Brake system

Air bleeding steps:

- a. Fill the reservoir with the proper brake fluid.
- b. Install the diaphragm. Be careful not to spill any fluid or allow the reservoir to overflow.
- c. Connect a clear plastic hose ① tightly to the caliper bleed screw ②.
- d. Place the other end of the hose into a container.
- e. Slowly apply the brake lever several times.
- f. Pull the lever in. Hold the lever in position.

- g. Loosen the bleed screw and allow the lever to travel towards its limit.
- h. Tighten the bleed screw when the lever limit has been reached, then release the lever.
- i. Repeat steps (e) to (h) until all the air bubbles have disappeared from the brake fluid.

NOTE:

When bleeding the brake system, make sure that there is always enough brake fluid in the brake fluid reservoir, before applying the brake lever. Ignoring this precaution could allow air to enter the brake system, lengthening the bleeding procedure, considerably.

- j. Tighten the bleed screw.



Bleed screw:
6 Nm (0.6 m · kg, 4.3 ft · lb)

NOTE:

If bleeding is difficult, it may be necessary to let the brake fluid settle for a few hours. Repeat the bleeding procedure when the tiny bubbles in the brake system have disappeared.

- k. Fill the brake fluid reservoir to the proper level.

Refer to "BRAKE FLUID LEVEL INSPECTION".

⚠ WARNING

After bleeding the brake system check the brake operation.

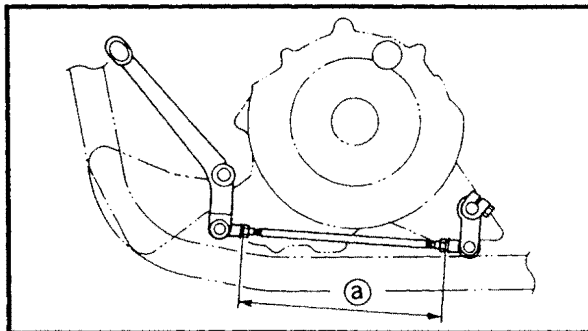

EB304080

SHIFT PEDAL ADJUSTMENT

- 1. Check:

- Shift pedal position
Check the shift pedal rod length ⓐ.
If the position is incorrect → Adjust.



Shift pedal rod length:
188 mm (7.4 in)

SHIFT PEDAL ADJUSTMENT/ FINAL GEAR OIL LEVEL INSPECTION

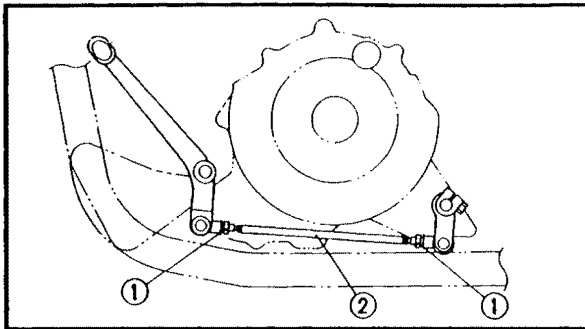

2.Adjust:

- Shift pedal position

Adjustment steps:

- Loosen both locknuts ①.
- To obtain the correct pedal position turn the shift pedal rod ② in or out.

Turning in:	shift pedal is lowered.
Turning out:	shift pedal is raised.

- Tighten both locknuts.

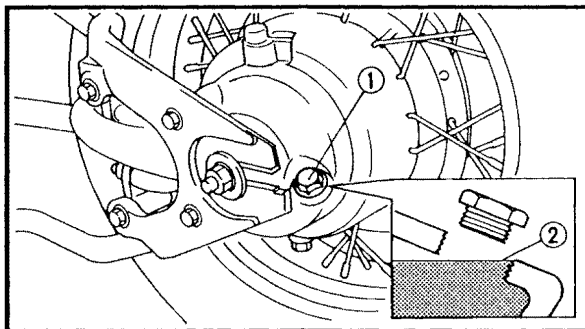

EB304110

FINAL GEAR OIL LEVEL INSPECTION

1.Stand the motorcycle on a level surface.

NOTE:

- When inspecting the final gear oil level, make sure the motorcycle is upright.
- Place the motorcycle on a suitable stand.

2.Remove:

- Oil filler bolt ①

3.Inspect:

- Oil level
Oil level should be to the bottom brim ② of the hole.
Oil level is too low → Add oil to the proper level.

	Recommended oil:
	SAE 80 API "GL-4" Hypoid gear oil If necessary an SAE 80W90 hypoid gear oil may be used for all conditions.

NOTE:

"GL-4" is a quality and additive rating. "GL-5" or "GL-6" rated hypoid gear oils may also be used.

4.Install:

- Oil filler bolt

23 Nm (2.3 m · kg, 17 ft · lb)

FINAL GEAR OIL REPLACEMENT/ STEERING HEAD INSPECTION

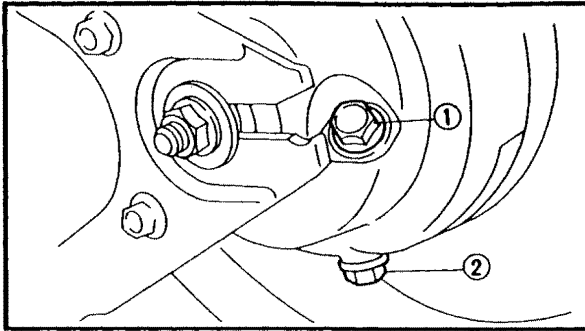

EB304120

FINAL GEAR OIL REPLACEMENT

1. Place a container under the final gear case.
2. Remove:
 - Oil filler bolt ①
 - Drain plug ②Drain the final gear case of its oil.
3. Install:
 - Drain plug  23 Nm (2.3 m · kg, 17 ft · lb)

NOTE:

Check the drain plug gasket. If it is damaged, replace it.

4. Fill:

- Final gear case



Oil quantity:
0.19 L

Refer to "FINAL GEAR OIL LEVEL INSPECTION".

5. Install:

- Oil filler bolt  23 Nm (2.3 m · kg, 17 ft · lb)

EB304130

STEERING HEAD INSPECTION

WARNING

Securely support the motorcycle so that there is no danger of it falling over.

1. Stand the motorcycle on a level surface.

NOTE:

Place the motorcycle on a suitable stand.

2. Elevate the front wheel by placing a suitable stand under the engine.
3. Check:
 - Steering assembly bearings
 - Grasp the bottom of the lower front fork tubes and gently rock the fork assembly.
 - Looseness → Adjust the steering head.

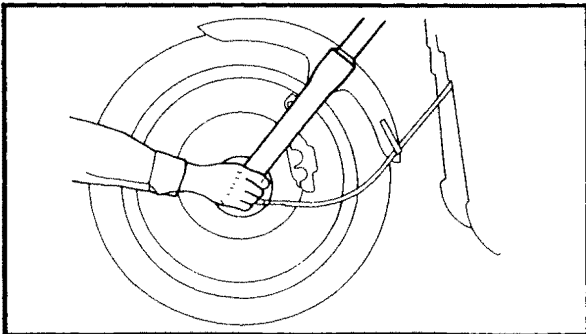

STEERING HEAD INSPECTION

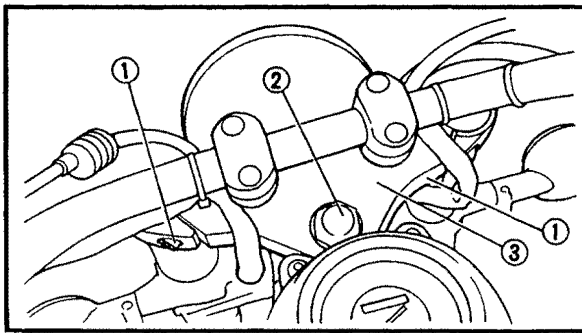

4. Loosen
- Front fork pinch bolts (upper) ①
5. Remove
- Steering stem nut ②
 - Upper bracket ③

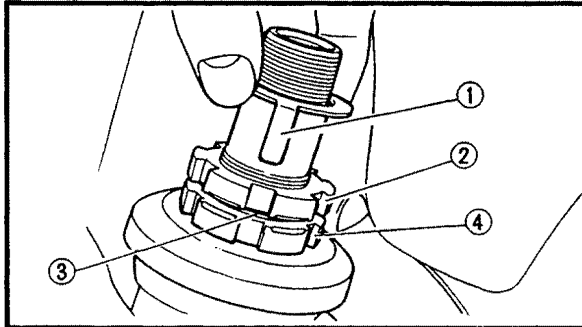



6. Adjust:
- Steering head
- *****

Adjustment steps:

- Remove the lock washer ①, the upper ring nut ② and the rubber washer ③.
- Loosen the lower ring nut ④.
- Tighten the lower ring nut using the ring nut wrench ⑤.

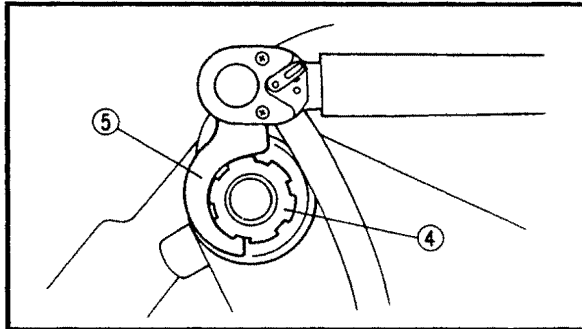
NOTE: _____
Set the torque wrench at a right angle to the ring nut wrench.



	Ring nut wrench: YU-33975, 90890-01403
--	--

	Lower ring nut: (initial tightening): 52 Nm (5.2 m • kg, 37.6 ft • lb)
--	--

- Loosen the lower ring nut ④ completely, then tighten it to specification.

⚠ WARNING _____
Do not overtighten the ring nut.

	Lower ring nut: (final tightening): 18 Nm (1.8 m • kg, 13 ft • lb)
--	--

STEERING HEAD INSPECTION/ FRONT FORK INSPECTION

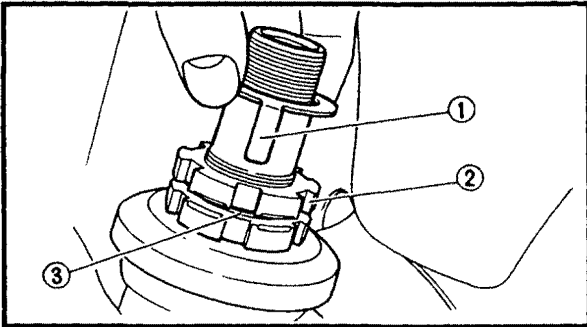

- Check the steering head for looseness or binding by turning it all the way, in both directions. If it binds, remove the steering stem assembly and inspect the steering bearings.

Refer to "STEERING HEAD AND HANDLE-BAR" in CHAPTER 6.

- Install the rubber washer ③.
- Install the upper ring nut ②.
- Finger tighten the upper ring nut ②, then align the slots of both ring nuts. If necessary, hold the lower ring nut and tighten the upper ring nut until their slots are aligned.
- Install the lock washer ①.

NOTE:

Make sure the lock washer tabs sit correctly in the ring nut slots.

7. Install:

- Upper bracket
- Steering stem nut
 - ✘ 110 Nm (11.0 m · kg, 79.6 ft · lb)
- Front fork pinch bolts (upper)
 - ✘ 20 Nm (2.0 m · kg, 14.5 ft · lb)

EB304140

FRONT FORK INSPECTION

⚠ WARNING

Securely support the motorcycle so that there is no danger of it falling over.

1. Stand the motorcycle on a level surface.
 2. Check:
 - Inner tube
 - Scratches/damage → Replace.
 - Oil seal
 - Excessive oil leakage → Replace.
 3. Hold the motorcycle upright and apply the front brake.
 4. Check:
 - Operation
 - Push down hard on the handlebars several times.
 - Unsmooth operation → Repair.
- Refer to "FRONT FORK" in CHAPTER 6.

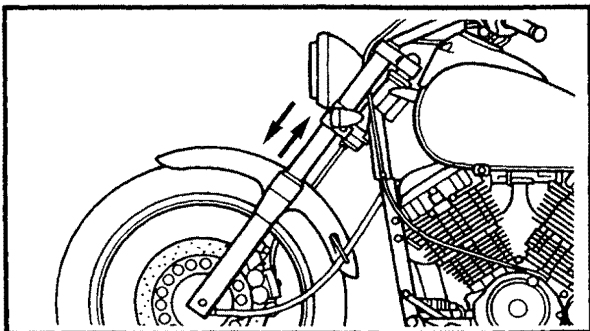

EB304160
REAR SHOCK ABSORBER ADJUSTMENT

⚠ WARNING

Securely support the motorcycle so that there is no danger of it falling over.

Spring preload

1. Adjust:
- Spring preload

NOTE:

Use the special wrench and extension bar included in the owner's tool kit to adjust the spring preload.

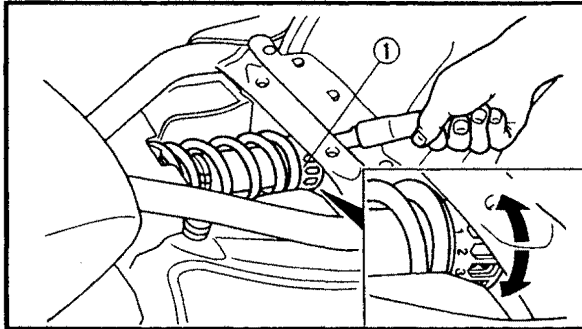

Adjustment steps:

- Turn the adjuster ① in or out.

Selecting a lower number:	Spring preload is softer.
Selecting a higher number:	Spring preload is harder.

Adjustment numbers:
Standard number: 3
Minimum number: 1
Maximum number: 7

CAUTION:

Never turn the adjuster beyond the maximum or minimum adjustment number.

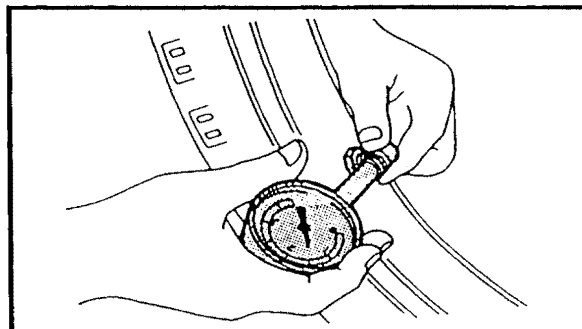

EB304170
TIRE INSPECTION

1. Measure:
- Tire inflation pressure
 Out of specification → Adjust.

⚠ WARNING

- Tire inflation pressure should only be checked and adjusted when the tire temperature equals the ambient air temperature. Tire inflation pressure and suspension must be adjusted according to the total weight of the cargo, rider, passenger and accessories (fairing, saddlebags, etc. if approved for this model), and according to whether the motorcycle will be operated at high speed or not. **NEVER OVERLOAD THE MOTORCYCLE.**
- Operation of an overloaded motorcycle could cause tire damage, an accident or injury.

Basic weight: With oil and full fuel tank	243 kg (535.7 lb)	
Maximum load*:	200 kg (440.9 lb)	
Cold tire pressure:	Front	Rear
Up to 90 kg (198 lb) load*	225 kPa (2.25 kgf/cm ² , 32.6 psi)	225kPa (2.25 kgf/cm ² , 32.6 psi)
90 kg (198 lb) ~ maximum load*	225 kPa (2.25 kgf/cm ² , 32.6 psi)	250 kPa (2.50 kgf/cm ² , 36.3 psi)
High speed riding	225 kPa (2.25 kgf/cm ² , 32.6 psi)	250 kPa (2.50 kgf/cm ² , 36.3 psi)

* Load is the total weight of the cargo, rider, passenger and accessories.

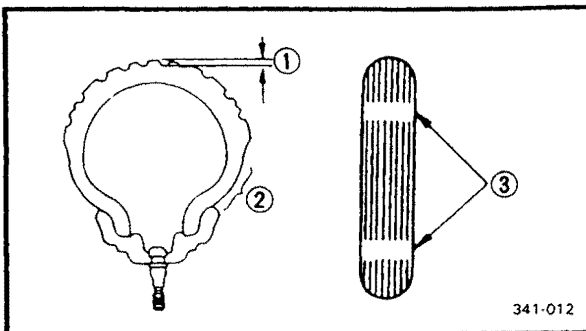

2. Inspect:

- Tire surfaces
Wear/damage → Replace.

	Minimum tire tread depth: (front and rear): 1.6 mm (0.06 in)
---	---

- ① Tread depth
- ② Side wall
- ③ Wear indicator

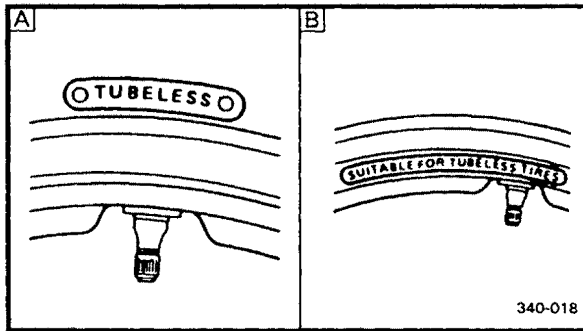

⚠ WARNING

- It is dangerous to ride with a worn-out tire. When the tire tread begins to show signs of wear, replace the tire immediately.
- Do not use tubeless tires on a wheel designed for tube type tires only. Tire failure and personal injury may result from sudden deflation.

A Tire **B** Wheel

Tube type wheel:	tube type tire only
Tubeless type wheel:	tube type or tubeless tire

- When using tube type tires be sure to install the correct tube.
- After extensive tests, the tires listed below have been approved by Yamaha Motor Co., Ltd. for this model. No guarantee concerning handling characteristics can be given if a tire combination, other than one approved by Yamaha, is used on this motorcycle. The front and rear tires should always be by the same manufacturer and of the same design.

FRONT TIRE:

Manufacturer	Size	Type
BRIDGESTONE	130/90-16 67S	G703
DUNLOP	130/90-16 67S	D404F

REAR TIRE:

Manufacturer	Size	Type
BRIDGESTONE	170/80-15M/C 77S	G702
DUNLOP	170/80-15M/C 77S	D404

⚠ WARNING

After mounting a tire, ride conservatively for a while to give the tire time to seat itself properly in the rim. Failure to do so could lead to an accident with possible injury to the rider or damage to the motorcycle.

EB304180

WHEEL INSPECTION

1. Inspect:

- Wheels
Bends/damage → Replace.

NOTE: _____

After a tire or wheel has been changed or replaced always balance the wheel.

WARNING _____

Never attempt to make any repairs to the wheels.

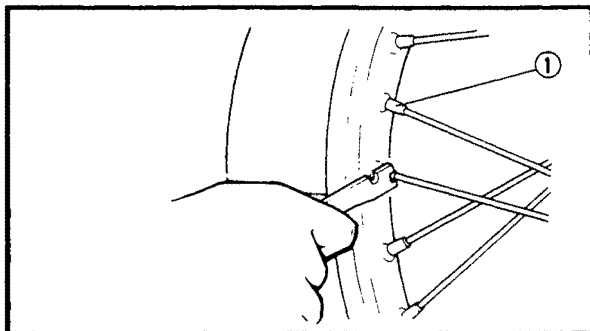

EB304190

SPOKE INSPECTION AND TIGHTENING

2. Inspect:

- Spokes ①
Bending/damage → Replace.
Loose spoke → Retighten.

3. Tighten:

- Spokes
- ② Spoke wrench

NOTE: _____

Be sure to tighten the spokes before and after break-in.

	Nipple: 3 Nm (0.3 m · kg, 2.2 ft · lb)
---	--

EB304200

CABLE INSPECTION AND LUBRICATION

WARNING _____

Damaged cable sheaths may cause corrosion and interfere with cable movements. Replace damaged cable sheaths and cables as soon as possible.

1. Inspect:

- Cable sheaths
Damage → Replace.

2. Check:

- Cable operation
Unsmooth operation → Lubricate.

	Recommended lubricant: Engine oil
--	--

NOTE: _____
Hold the cable end upright and pour a few drops of lubricant into the cable sheath.

EB304210

LEVER AND PEDAL LUBRICATION

Lubricate the pivoting points on the levers and pedals.

	Recommended lubricant: Lithium soap base grease
--	--

EB304220

SIDESTAND LUBRICATION

Lubricate the pivoting point and the contact surfaces on the sidestand.

	Recommended lubricant: Lithium soap base grease
--	--

EB305000

ELECTRICAL**BATTERY INSPECTION****NOTE:**

Since the MF battery is a sealed type battery, it is not possible to measure the specific gravity of the electrolyte in order to check the charge state of the battery. Therefore the charge of the battery has to be checked by measuring the voltage at the battery terminals.

CAUTION:**CHARGING METHOD**

- This is a sealed type battery. Never remove the sealing caps. If the sealing caps have been removed, the balance will not be maintained and battery performance will deteriorate.
- Charging time, charging current and charging voltage for the MF battery are different from those of general type batteries. The MF battery should be charged as explained in "CHARGING METHOD". If the battery is overcharged, the electrolyte level will drop considerably. Therefore, take special care when charging the battery.

⚠ WARNING

Battery electrolyte is dangerous; it contains sulfuric acid which is poisonous and highly caustic.

Always follow these preventive measures:

- Avoid bodily contact with electrolyte as it can cause severe burns or permanent eye injury.
- Wear protective eye gear when handling or working near batteries.

Antidote (EXTERNAL):

- SKIN - Wash with water.
- EYES - Flush with water for 15 minutes and get immediate medical attention.

Antidote (INTERNAL):

- Drink large quantities of water or milk followed with milk of magnesia, beaten egg or vegetable oil. Get immediate medical attention.

Batteries generate explosive hydrogen gas. Always follow these preventive measures:

- Charge batteries in a well-ventilated area.
- Keep batteries away from fire, sparks or open flames (e.g., welding equipment, lighted cigarettes, etc.)
- DO NOT SMOKE when charging or handling batteries.

KEEP BATTERIES AND ELECTROLYTE OUT OF REACH OF CHILDREN.

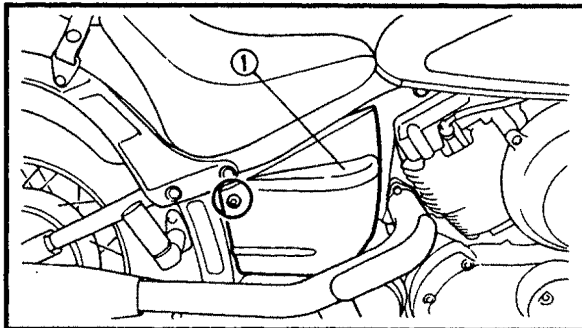

- 1.Remove:
- Rider's seat
Refer to "FUEL TANK AND SEATS".
 - Battery cover ①

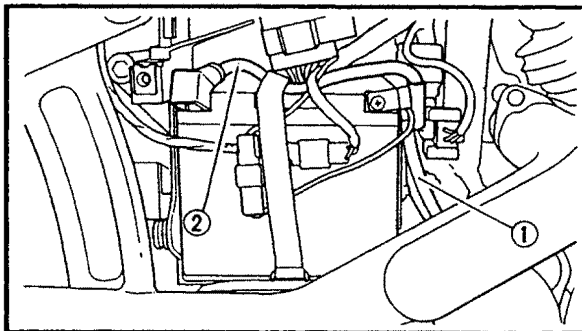

- 2.Disconnect:
- Battery leads

CAUTION: First disconnect the negative lead ①, then disconnect the positive lead ②.

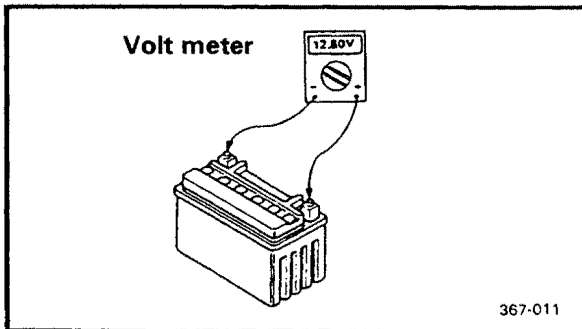

- 3.Remove:
- Battery band
 - Battery
- 4.Check:
- Battery condition

Battery condition checking steps:

- Connect a digital voltmeter to the battery terminals.

Tester (+) lead → battery (+) terminal
 Tester (-) lead → battery (-) terminal

NOTE: The charge state of an MF battery can be checked by measuring the open-circuit voltage (i.e. the voltage when the positive terminal is disconnected).

Open-circuit voltage	Charging time
12.8V or higher	No charging is necessary.

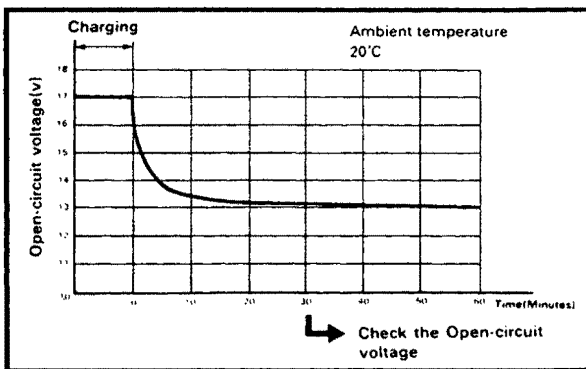
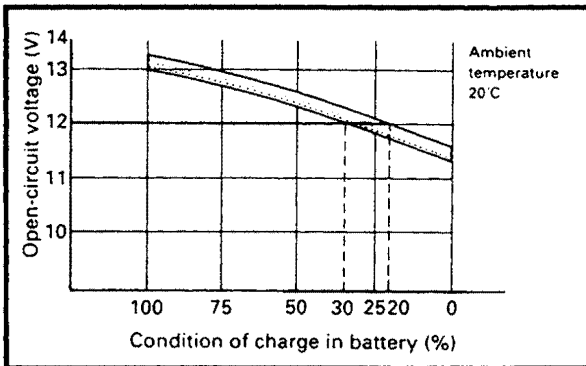
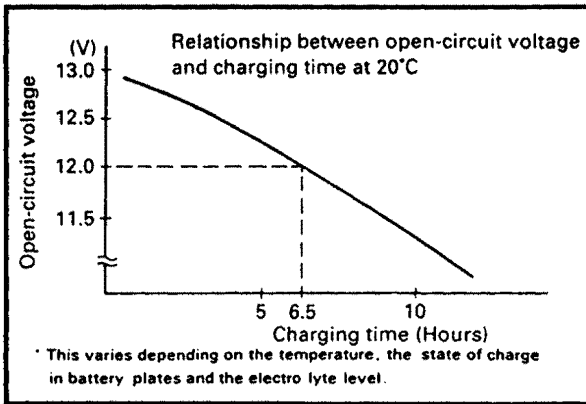

- Check the condition of the battery using the following charts.

Example:

- Open-circuit voltage = 12.0V
- Charging time = 6.5 hours
- Charge condition of the battery = 20 ~ 30%
- Charging method for MF batteries

CAUTION:

- If it is impossible to set the standard charging current, be careful not to over-charge.
- When charging the battery, be sure to remove it from the motorcycle. (If charging has to be done with the battery mounted on the motorcycle, be sure to disconnect the wire at the negative terminal.)
- Never remove the sealing caps of an MF battery.
- Make sure that the charging clips are in full contact with the terminal and that they are not shorted together. (A corroded clip on the charger may cause the battery to generate heat in the contact area. A weak clip spring may cause sparks.)
- Before removing the clips from the battery terminals, be sure to turn off the charger's power switch.
- The open-circuit voltage variation for the MF battery, after charging, is shown below. As shown in the figure, the open-circuit voltage stabilizes about 30 minutes after charging has been completed. Therefore, wait 30 minutes after charging is completed before measuring the open-circuit voltage.

Charging method using a variable-current (voltage) type charger

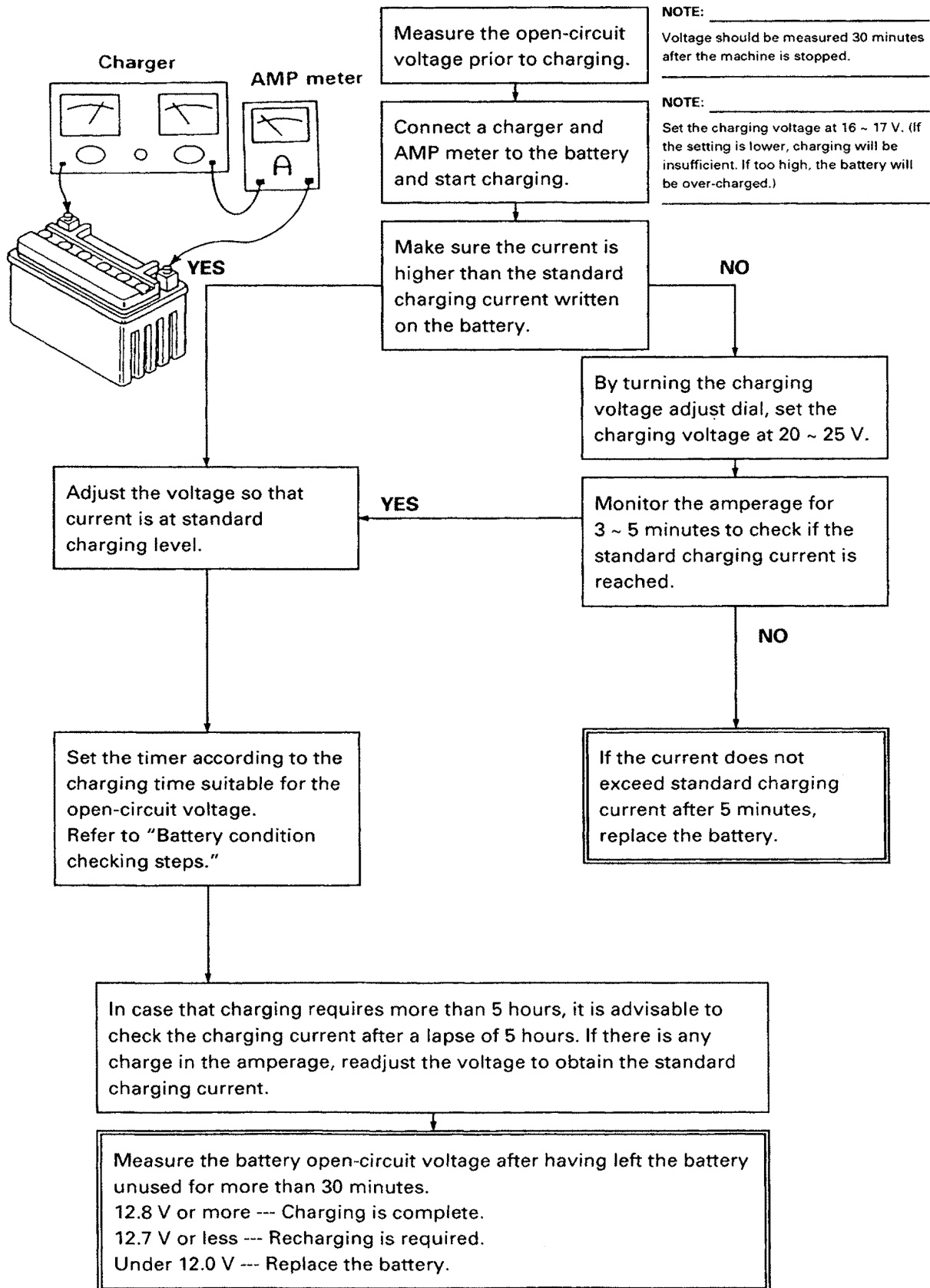

Charging method using a constant-voltage type charger

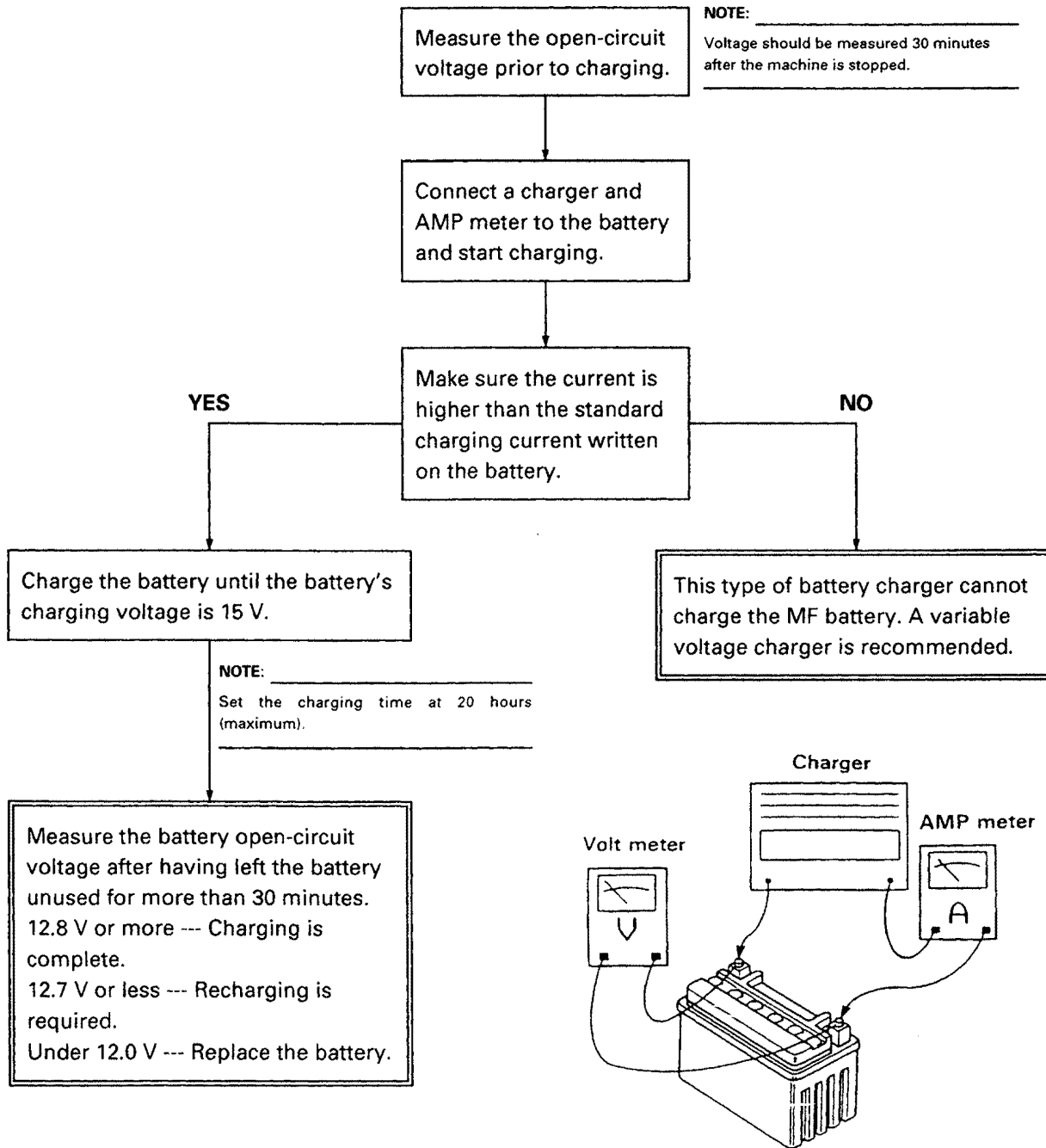

Charging method using a constant-current type charger

This type of battery charger cannot charge the MF battery.

5. Inspect:

- Battery terminals
Dirty → Clean with a wire brush.
Poor connection → Correct.

NOTE: _____

After cleaning the terminals, apply a light coat of grease.

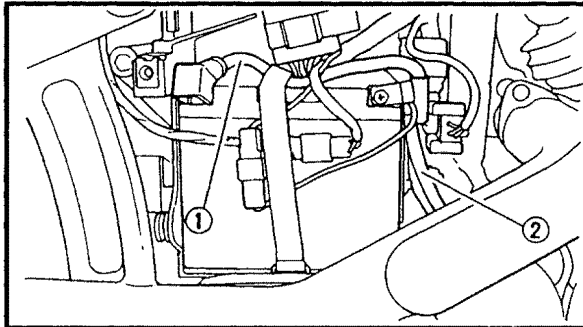

6. Install:

- Battery
- Battery band

7. Connect:

- Battery leads

CAUTION: _____

First, connect the positive lead ①, then connect the negative lead ②.

8. Install:

- Rider's seat
Refer to "FUEL TANK AND SEATS".

EB305010

FUSE INSPECTION

CAUTION: _____

When checking or replacing the fuse always turn off the main switch. Otherwise, a short circuit may occur.

1. Remove:

- Battery cover

2. Inspect:

- Fuses

Inspection steps:

- Connect the pocket tester and check the fuse for continuity.

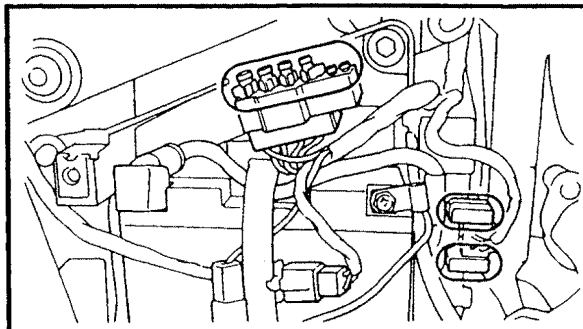

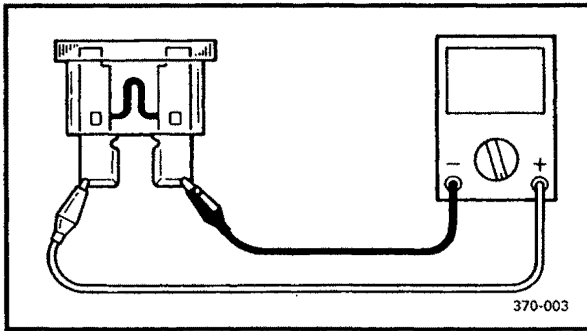

NOTE: _____
Set the tester selector to " $\Omega \times 1$ ".

 **Pocket tester:**
YU-03112, 90890-03112

● If the tester indicates ∞ , replace the fuse.

3. Replace:

- Blown fuse
- *****

Replacement steps:

- Turn off the main switch.
- Install a new fuse with the proper current rating.
- Turn on switches to verify operation of related electrical devices.
- If the fuse blows again, immediately check the electrical circuit.

Description	Current rating	Quantity
Main	30A	1
Headlight	15A	1
Carburetor heater	15A	1
Signals	10A	1
Ignition	10A	1
Reserve	30A	1
Reserve	15A	1
Reserve	10A	1

⚠ WARNING _____

Never use a fuse with a rating other than that specified. Never use other materials in place of a fuse. An improper fuse may cause extensive damage to the electrical system, a malfunction of the lighting and ignition systems and could possibly cause a fire.

4. Install:

- Battery cover

HEADLIGHT BEAM ADJUSTMENT/ HEADLIGHT BULB REPLACEMENT

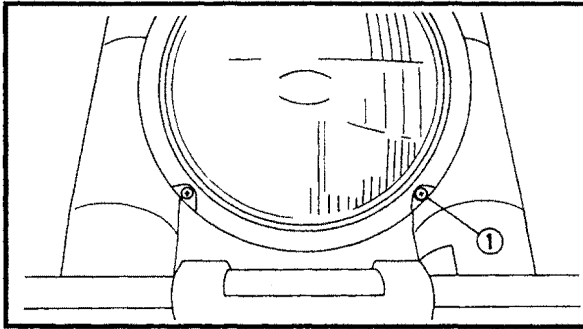

EB305020

HEADLIGHT BEAM ADJUSTMENT

1. Adjust:

- Headlight beam (vertically)
Turn the adjuster ① in or out.

Turning in:	headlight beam is raised.
Turning out:	headlight beam is lowered.

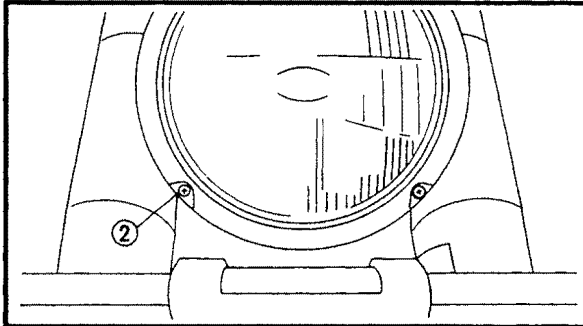

2. Adjust:

- Headlight beam (horizontally)
Turn the adjuster ② in or out.

Turning in:	headlight beam to the left.
Turning out:	headlight beam to the right.

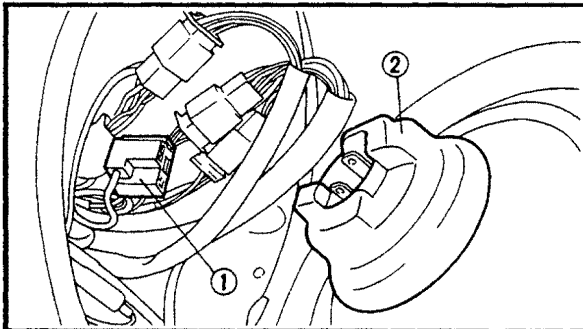

EB305030

HEADLIGHT BULB REPLACEMENT

1. Remove:

- Headlight lens unit

2. Disconnect:

- Leads (in headlight body) ①

3. Remove:

- Bulb cover ②

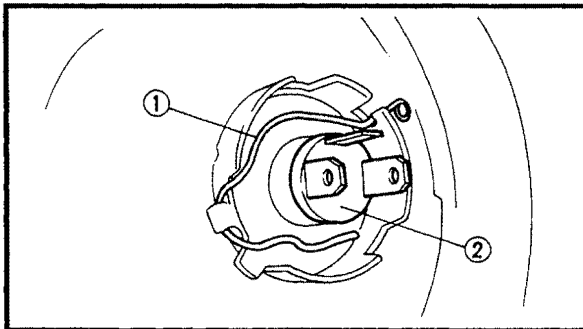

4. Unhook:

- Bulb holder ①

5. Remove:

- Bulb ②

⚠ WARNING

Since the bulb may be hot, keep flammable products and your hands away from it. Do not touch the bulb until it has cooled down.

6. Install:

- Bulb (new)

Secure the new bulb with the bulb holder.



CAUTION:

Avoid touching the glass part of the bulb. Keep it free from oil, otherwise the transparency of the glass, life of the bulb and the luminous flux will be adversely affected. If oil gets on the bulb, thoroughly clean it with a cloth moistened with alcohol or lacquer thinner.

7. Hook up:

- Bulb holder

8. Install:

- Bulb cover

9. Connect:

- Leads (in headlight body)

10. Install:

- Headlight lens unit



ENGINE

ENGINE REMOVAL

MUFFLERS, BRAKE PEDAL AND SIDE COVER

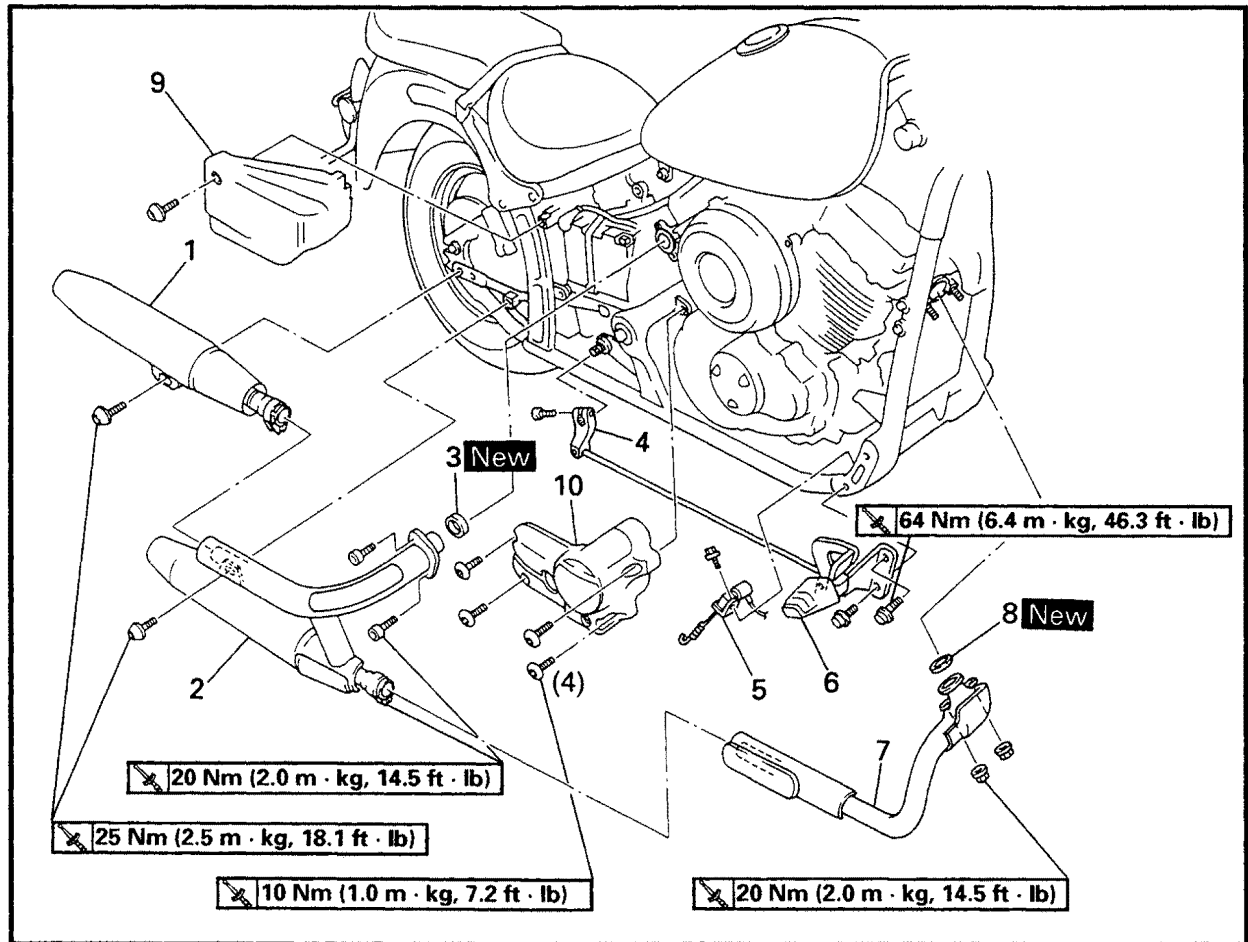

4

Order	Job name/Part name	Q'ty	Remarks
	Muffler, brake pedal and side cover removal		Remove the parts in the order below. Stand the motorcycle on a level surface. ⚠ WARNING Securely support the motorcycle so there is no danger of it falling over.
1	Muffler assembly (upper)	1	
2	Muffler assembly (lower)	1	
3	Exhaust pipe gasket	1	
4	Brake pedal link	1	Refer to "BRAKE PEDAL INSTALLATION".
5	Rear brake switch	1	
6	Brake pedal/footrest (right)	1/1	
7	Exhaust pipe	1	
8	Exhaust pipe gasket	1	

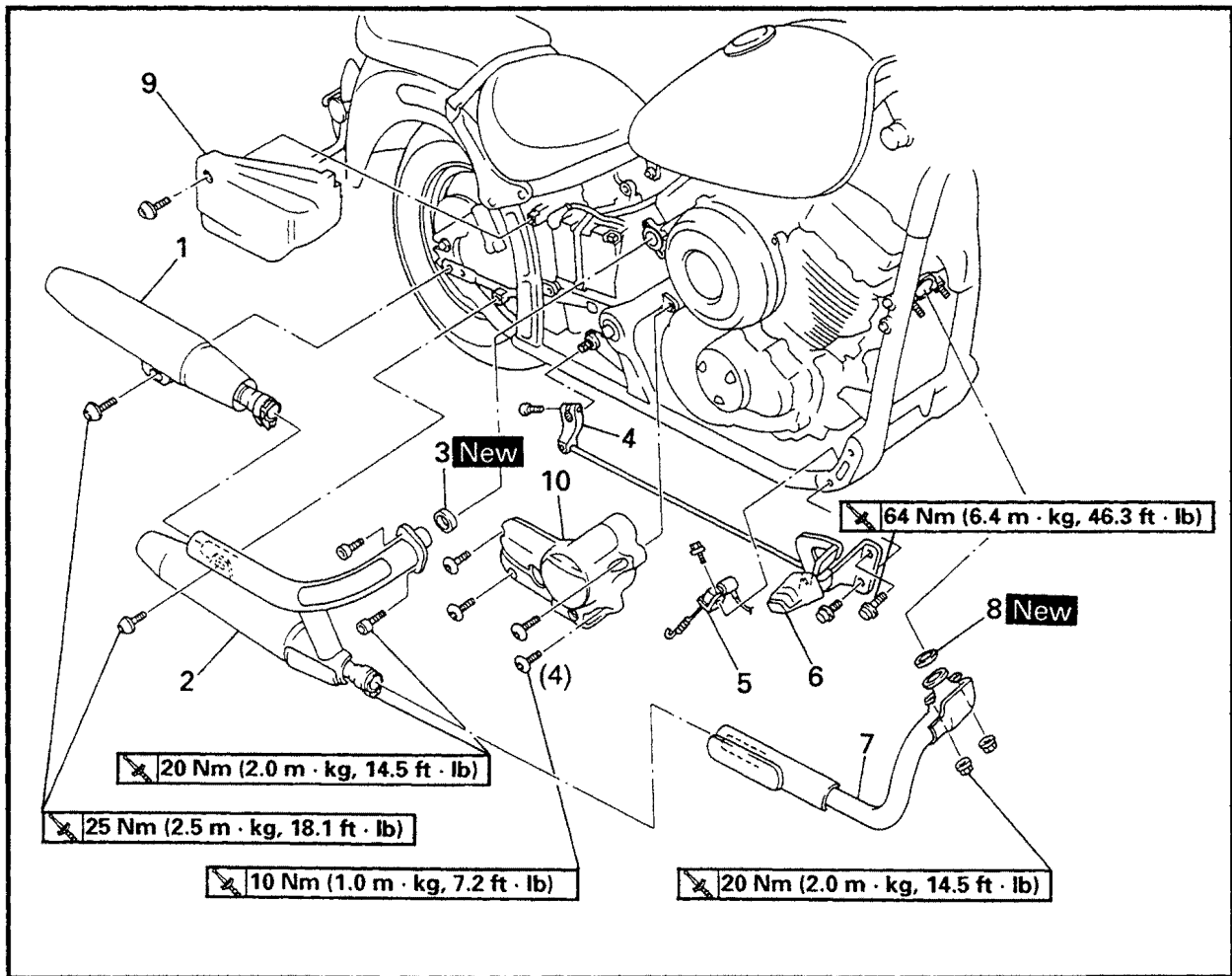

Order	Job name/Part name	Q'ty	Remarks
9	Battery cover	1	For installation, reverse the removal procedure.
10	Side cover (right)	1	



CYLINDER HEAD COVERS

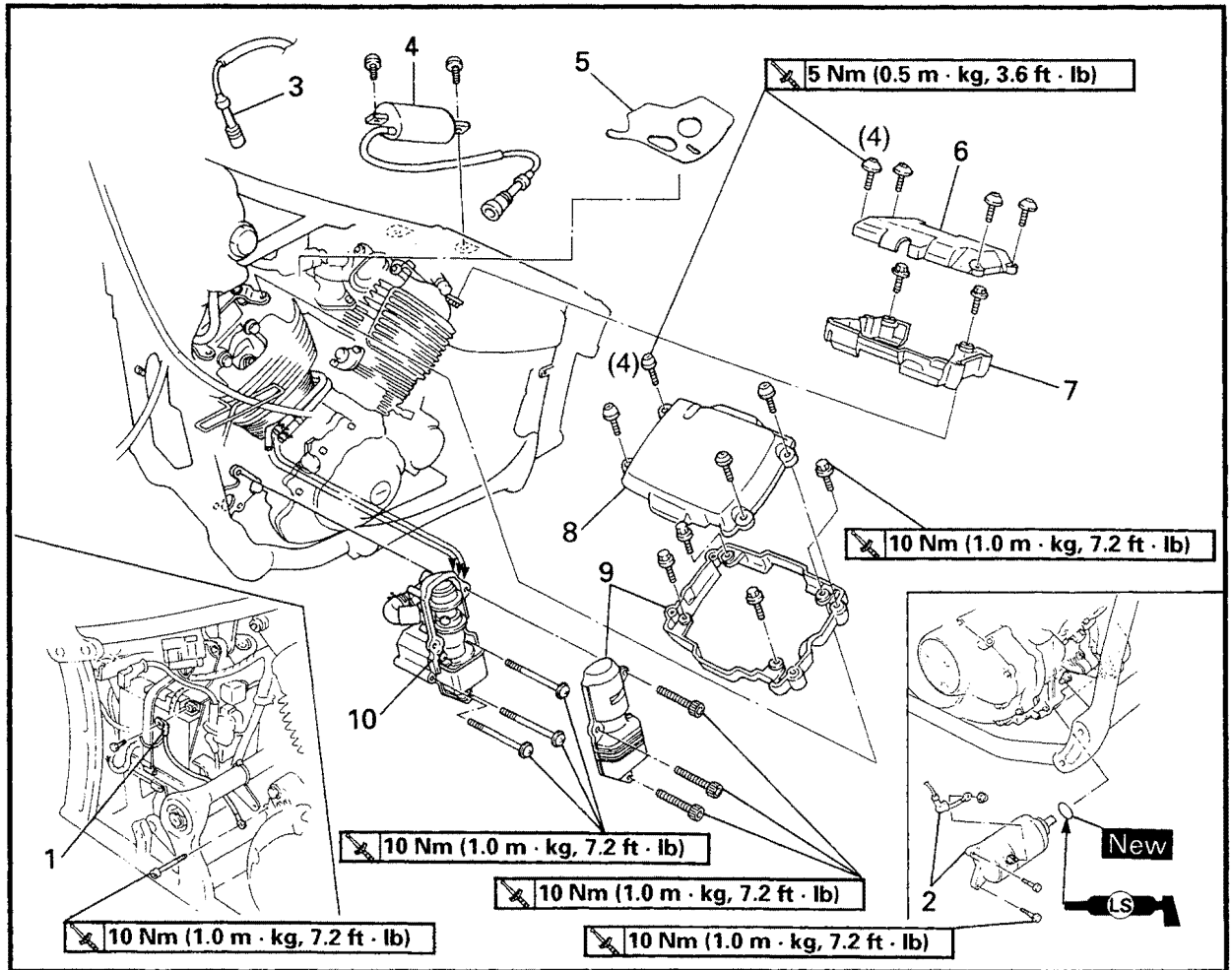

Order	Job name/Part name	Q'ty	Remarks
	Cylinder head covers removal		Remove the parts in the order below.
	Fuel tank		Refer to "FUEL TANK AND SEATS" in CHAPTER 3.
	Carburetor assembly		Refer to "CARBURETOR" in CHAPTER 5.
1	Battery leads	2	Disconnect NOTE: _____ First, disconnect the negative lead, then disconnect the positive lead.
2	Starter motor assembly	1	
3	Spark plug cap	1	
4	Ignition coil (cylinder #1 side)	1	
5	Baffle cover	1	
6	Upper cylinder head cover (rear)	1	
7	Lower cylinder head cover (rear)	1	
8	Upper cylinder head cover (front)	1	

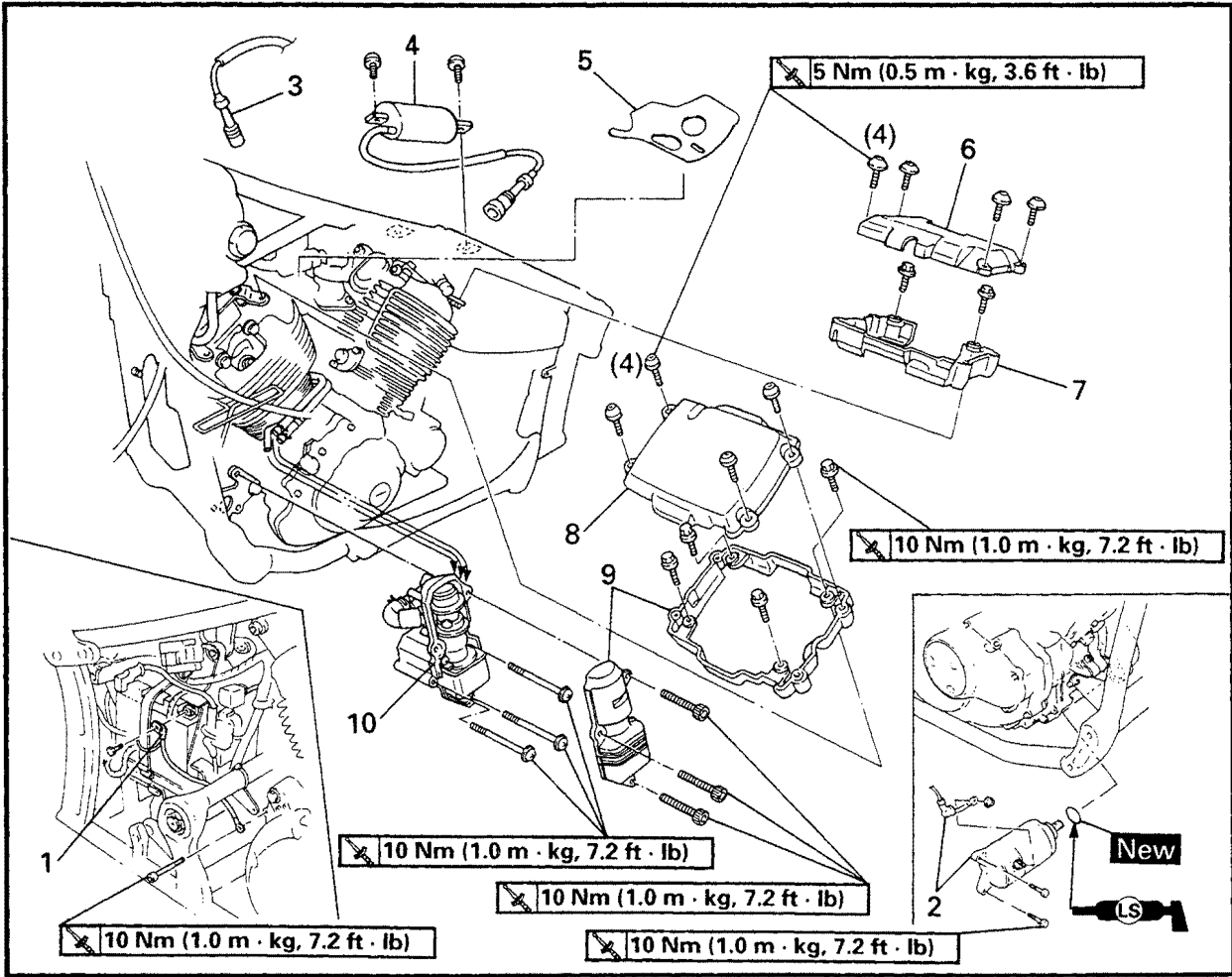

Order	Job name/Part name	Q'ty	Remarks
9	Lower cylinder head cover (front)	1	For installation, reverse the removal procedure.
10	Cover	1	
11	AIS ass'y	1	



SIDESTAND AND CRANKCASE COVER (LEFT)

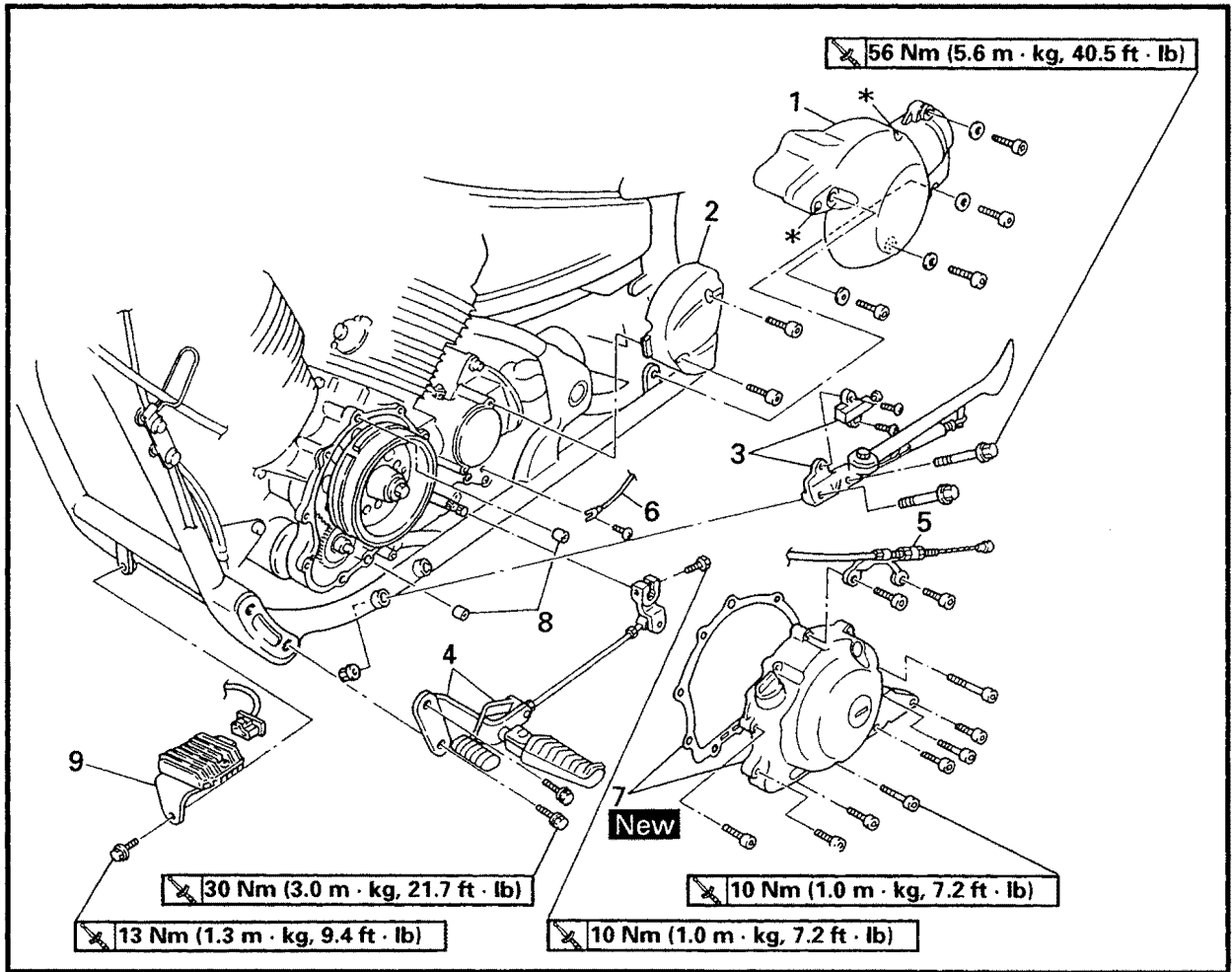

Order	Job name/Part name	Q'ty	Remarks
	Side stand and crankcase cover (left) removal		Remove the parts in the order below.
	Engine oil		Drain Refer to "ENGINE OIL REPLACEMENT" in CHAPTER 3.
1	Side cover (left)	1	Do not remove the "*" bolts.
2	Middle gear case cover	1	
3	Sidestand assembly	1	
4	Shift pedal/footrest (left)	1/1	Refer to "SHIFT PEDAL INSTALLATION".
5	Clutch cable	1	
6	Neutral switch lead	1	
7	Crankcase cover (left)/gasket	1/1	
8	Dowel pins	2	
9	Rectifier/regulator	1	
			For installation, reverse the removal procedure.



ENGINE MOUNTING BOLTS

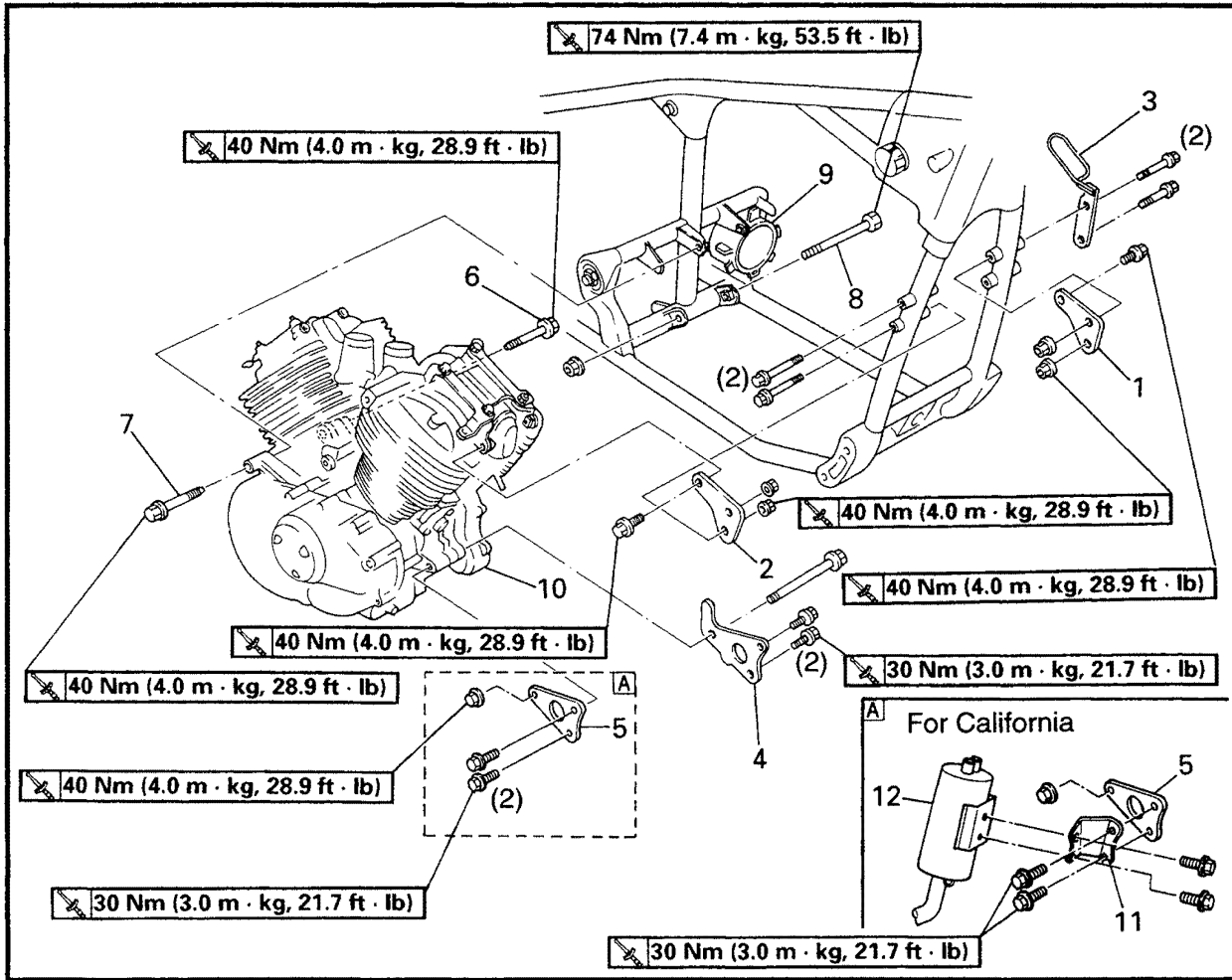

Order	Job name/Part name	Q'ty	Remarks
	Engine mounting bolt removal		Remove the parts in the order below. Place a suitable stand under the frame and engine.
			⚠ WARNING Securely support the motorcycle so there is no danger of it falling over.
1	Engine stay (front-upper/left)	1	
2	Engine stay (front-upper/right)	1	
3	Cable holder	1	
4	Engine stay (front-lower/left)	1	
5	Engine stay (front-lower/right)	1	
6	Engine mounting bolt (rear-upper/left)	1	L=75mm (2.95 in)
7	Engine mounting bolt (rear-upper/right)	1	L=60mm (2.36 in)

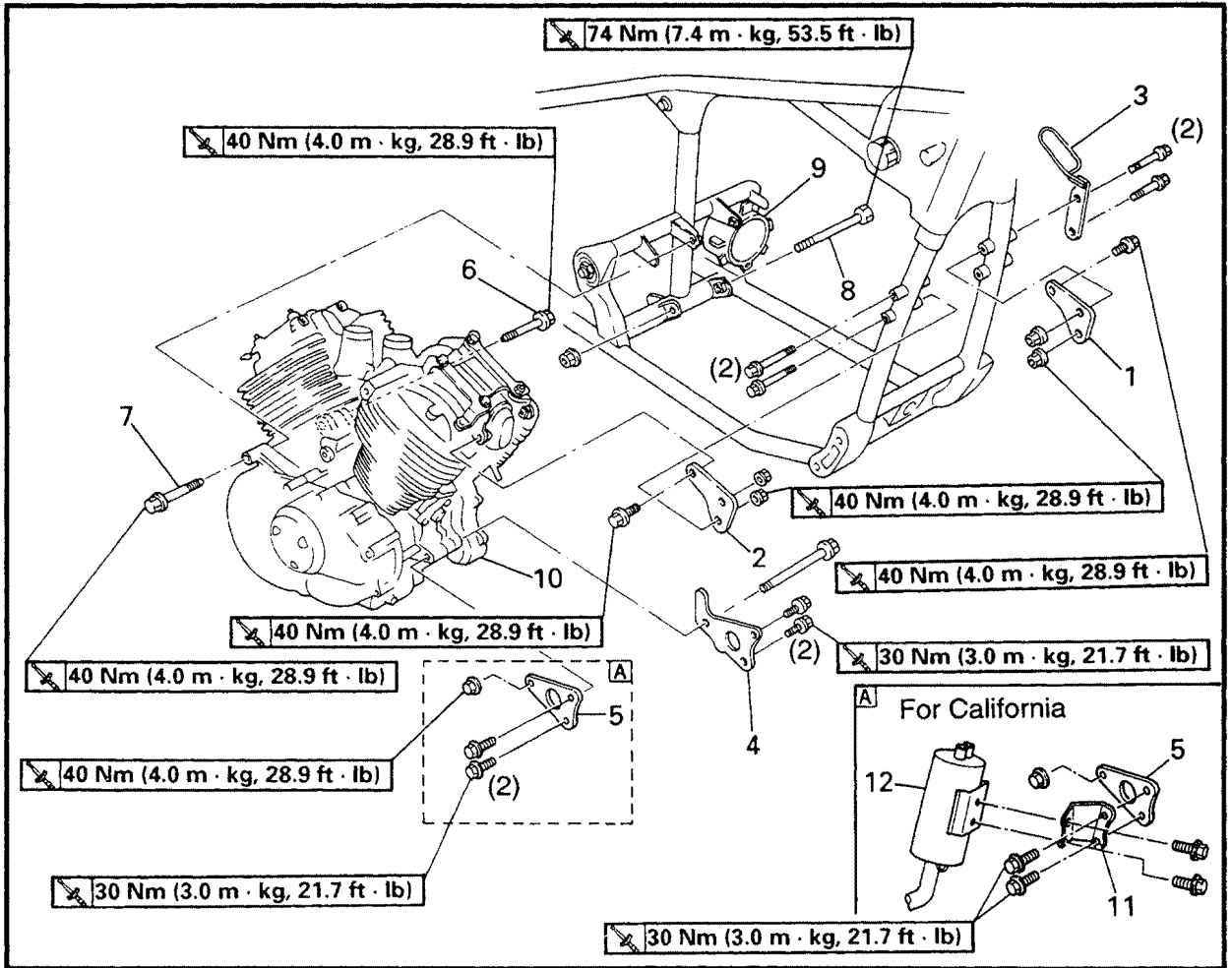

Order	Job name/Part name	Q'ty	Remarks
8	Engine mounting bolt (rear-lower)	1	L=150mm (5.9 in)
9	Rubber boot	1	
10	Engine assembly	1	NOTE: _____ Remove the engine assembly from the right side of the motorcycle.
11	Canister bracket	1	
12	Canister ass'y	1	For California
			For installation, reverse the removal procedure.

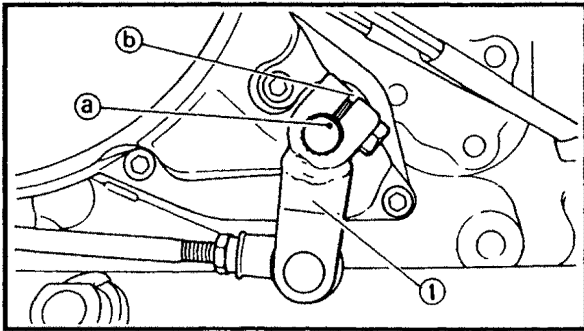

SHIFT PEDAL INSTALLATION

1.Connect

- Shift pedal link ①

10 Nm (1.0 m · kg, 7.2 ft · lb)

NOTE:

Align the punch mark ① on the shift rod with the slot ② on the shift pedal link

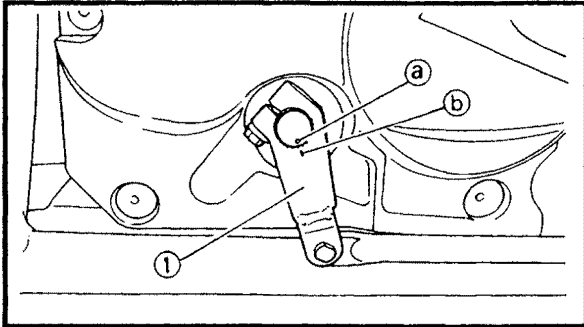

BRAKE PEDAL INSTALLATION

1.Connect

- Brake pedal link ①

10 Nm (1.0 m · kg, 7.2 ft · lb)

NOTE:

Align the punch mark ① on the brake rod with the slot ② on the brake pedal link.



CYLINDER HEADS

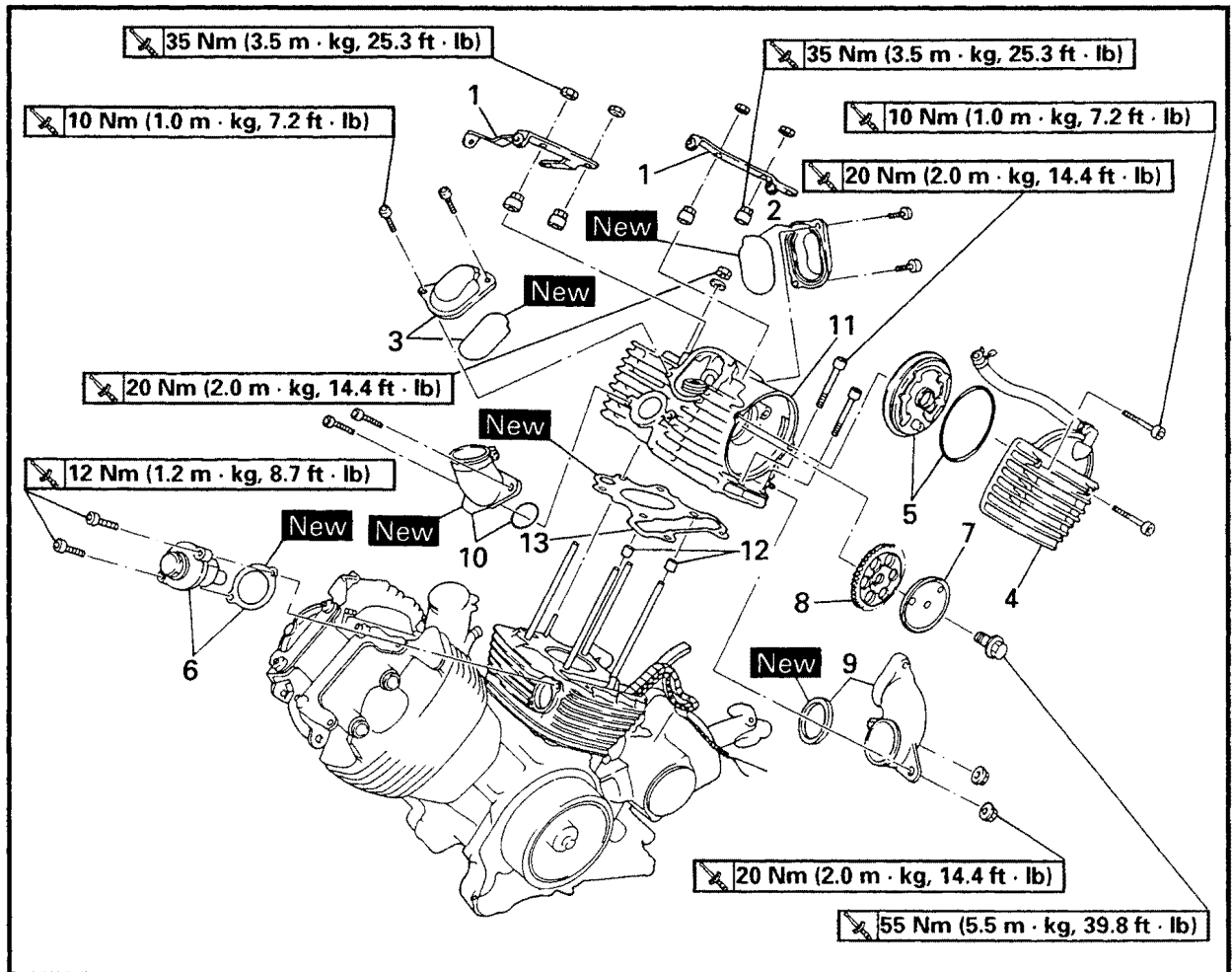

Order	Job name/Part name	Q'ty	Remarks
	Cylinder head removal		Remove the parts in the order below. Refer to "ENGINE REMOVAL".
	Engine assembly		
1	Cylinder head cover brackets	2	
2	Tappet cover (exhaust)/O-ring	1/1	
3	Tappet cover (intake)/O-ring	1/1	
4	Camshaft sprocket cover/O-ring	1/1	
5	Baffle plate/O-ring (only rear cylinder head)	1/1	
6	Timing chain tensioner/gasket	1/1	
7	Camshaft sprocket plate (only rear cylinder head)	1	
8	Camshaft sprocket	1	
9	Exhaust pipe joint (rear)/gasket	1/1	
10	Carburetor joint/O-ring	1/1	
11	Cylinder head	1	Refer to "CYLINDER HEAD REMOVAL/INSTALLATION".

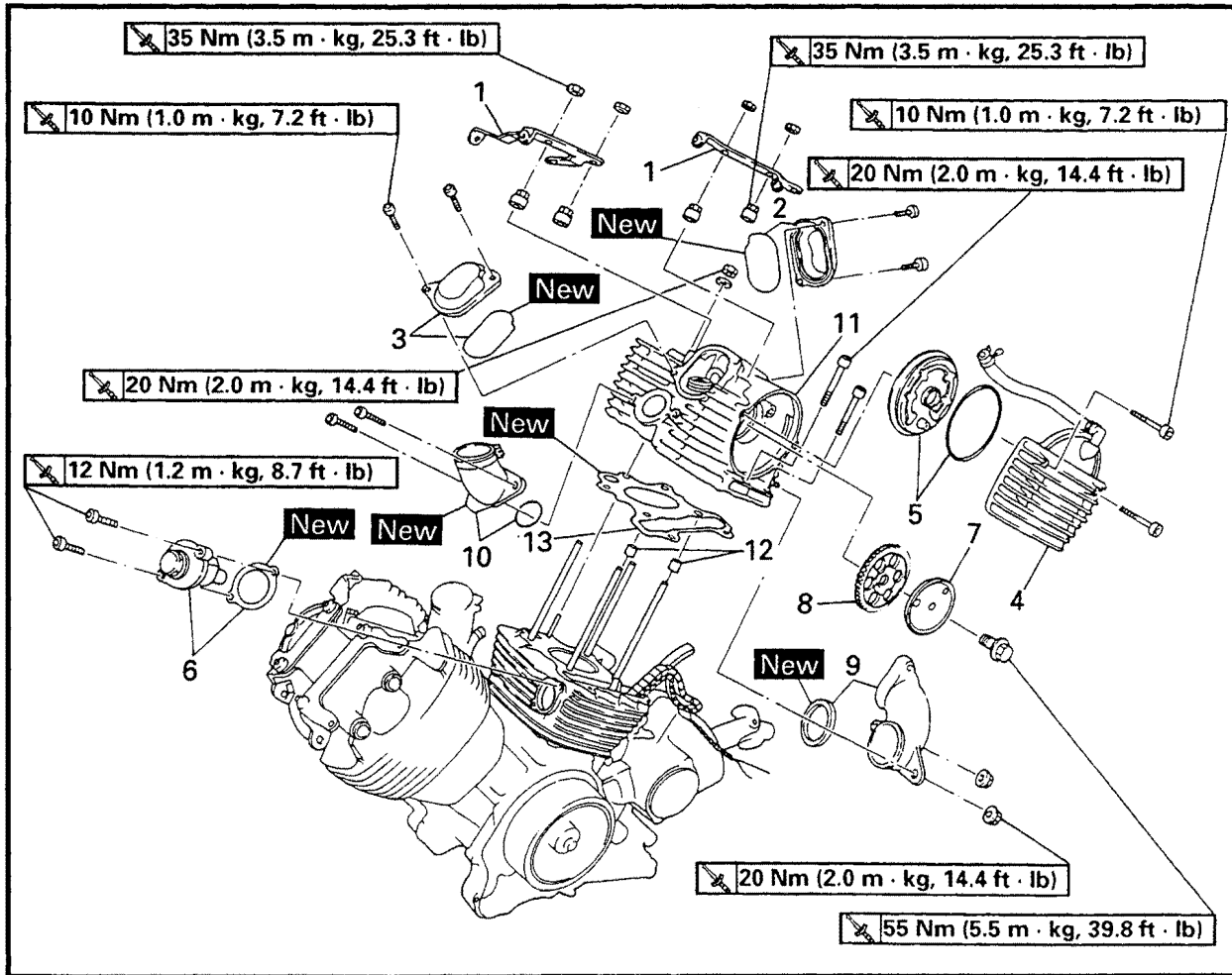

Order	Job name/Part name	Q'ty	Remarks
12	Dowel pins	2	For installation, reverse the removal procedure.
13	Cylinder head gasket	1	

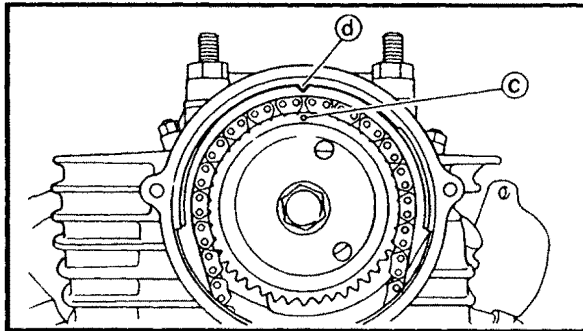
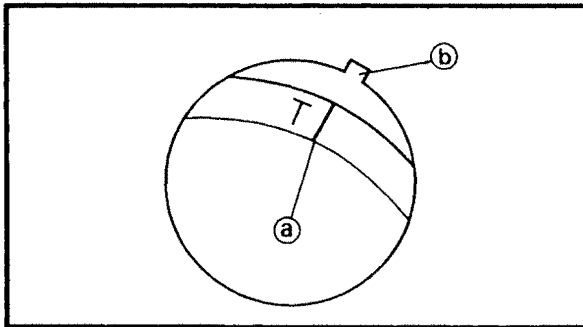

CYLINDER HEAD REMOVAL

Rear cylinder head

1.Align:

- "T" mark
(with the stationary pointer)

Removal steps:

- Temporarily install the AC magneto cover without the pickup coil and stator coil.
- Turn the crankshaft clockwise.
- Align the "T" mark ① with the stationary pointer ② on the crankcase cover (left) when the rear piston is at TDC on the compression stroke.
- When the "T" mark is aligned with the stationary pointer the punch mark ③ on the camshaft sprocket should be aligned with the stationary pointer ④ on the cylinder head.
- The rear piston is at TDC on the compression stroke when there is clearance at both of the rocker arms. If there is no clearance then turn the crankshaft clockwise one full turn.
- Check that the rear piston is at TDC in the compression stroke.

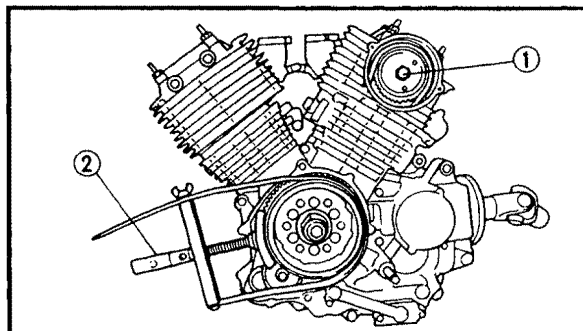

2.Loosen:

- Bolt (camshaft sprocket) ①

NOTE:

Use the sheave holder ② to hold the rotor.



Sheave holder:
YS-01880, 90890-01701

3.Loosen:

- Cap bolt (timing chain tensioner)

4.Remove:

- Timing chain tensioner
- Gasket

5.Remove:

- Bolt (camshaft sprocket) ①
- Camshaft sprocket plate ② (only rear)
- Camshaft sprocket ③

NOTE:

To prevent the timing chain from falling into the crankcase fasten a wire to it.

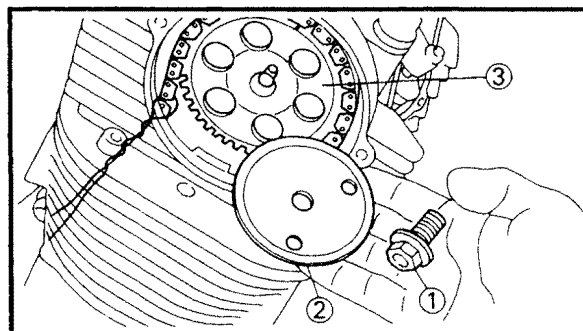

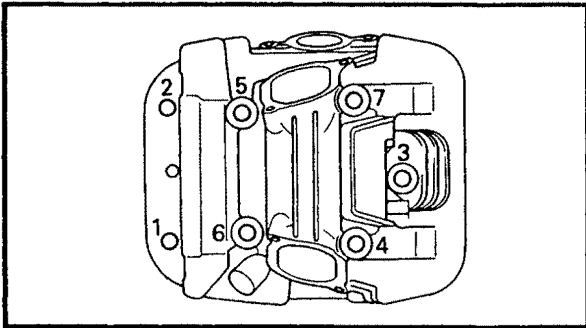

- 6.Remove:
- Cylinder head

- NOTE:** _____
- Loosen the bolts and nuts in the proper sequence.
 - Follow the numerical order shown in the illustration. Loosen each bolt 1/4 of a turn at a time until all of the bolts are loose.

Front cylinder head

- NOTE:** _____
- When removing the front cylinder head camshafts, repeat the rear cylinder head camshafts removal procedures. However, note the following points.

- 1.Align:
- "I" mark
(with the stationary pointer)

Removal steps:

- Turn the crankshaft clockwise 290°.
- Align the "I" mark (a) with the stationary pointer (b) on the crankcase cover (left) when the front piston is at TDC on the compression stroke.
- When the "I" mark is aligned with the stationary pointer the punch mark (c) on the camshaft sprocket should be aligned with the stationary pointer (d) on the cylinder head.
- The front piston is at TDC on the compression stroke when there is clearance at both of the rocker arms. If there is no clearance then turn the crankshaft clockwise one full turn.
- Check that the front piston is at TDC in the compression stroke.

CYLINDER HEAD INSPECTION

- 1.Eliminate:
- Carbon deposits (from the combustion chambers)
Use a rounded scraper.

- NOTE:** _____
- Do not use a sharp instrument to avoid damaging or scratching:
- Spark plug threads
 - Valve seats

- 2.Inspect:
- Cylinder heads
Scratches/damage → Replace.

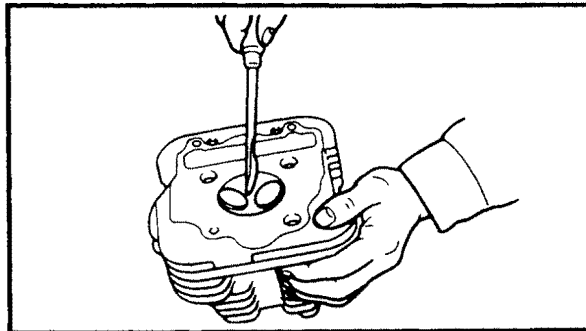
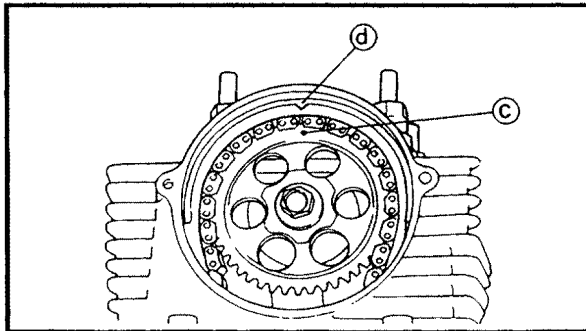
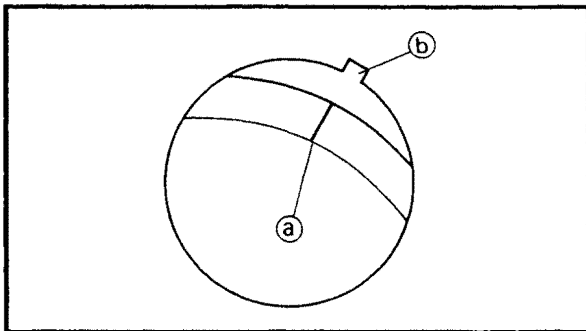

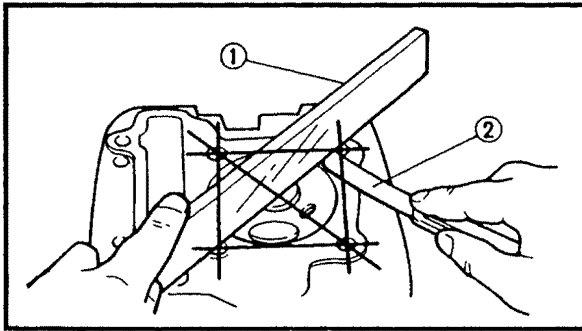

3.Measure:

- Cylinder head warpage
Out of specification → Resurface.

	<p>Cylinder head warpage: Less than 0.03 mm (0.001 in)</p>
--	---

Warpage measurement and resurfacement steps:

- Place a straightedge ① and a feeler gauge ② across the cylinder head.
- Use a feeler gauge to measure the warpage.
- If the warpage is out of specification, resurface the cylinder head.
- Place a 400 ~ 600 grit wet sandpaper on the surface plate, and resurface the head using a figure-eight sanding pattern.

NOTE: _____

To ensure an even surface rotate the cylinder head several times.

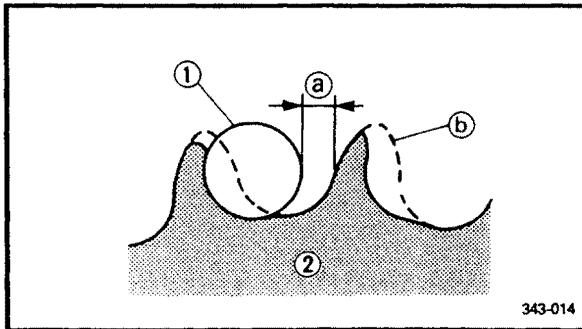

343-014

4.Inspect:

- Camshaft sprockets
Wear/damage → Replace the camshaft sprockets and the timing chain as a set.
- Ⓐ 1/4 tooth
- Ⓑ Correct
- ① Roller
- ② Sprocket

5.Check:

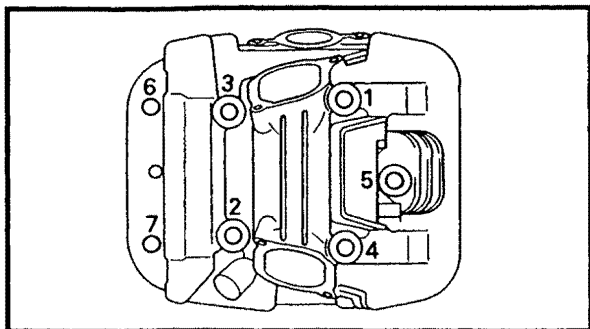

- One-way cam operation (tensioner)
Unsmooth operation → Replace.



CYLINDER HEAD INSTALLATION

Rear cylinder head

1.Install:

- Nuts (cylinder head) (M10:1~4)
 -  **35 Nm (3.5 m · kg, 25.3 ft · lb)**
- Bolts (cylinder head) (M8:5~7)
 -  **20 Nm (2.0 m · kg, 14.4 ft · lb)**

NOTE:

- Tighten the bolts and nuts in the proper sequence.
- Follow the numerical order shown in the illustration. Tighten the bolts and nuts in two stages.

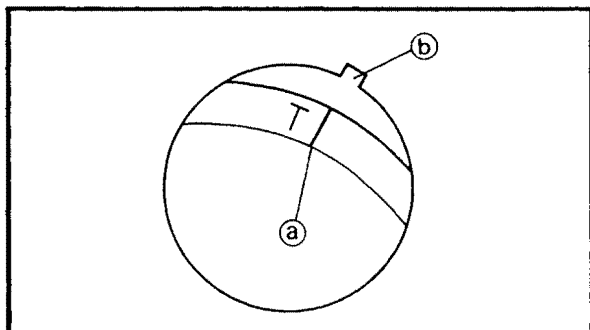

2.Install:

- Camshaft sprocket

Installation steps:

- Turn the crankshaft clockwise.
- Align the "T" mark ① with the stationary pointer ② on the crankcase cover (left).
- Install the camshaft sprocket with the timing mark ③ facing out.
- Turn the camshaft just enough to remove any slack from the exhaust side of the timing chain.
- Insert your finger into the hole and timing chain tensioner hole and push the timing chain guide inward.
- While pushing the timing chain guide, be sure that the timing mark ④ and the stationary pointer ⑤ are properly aligned at TDC.

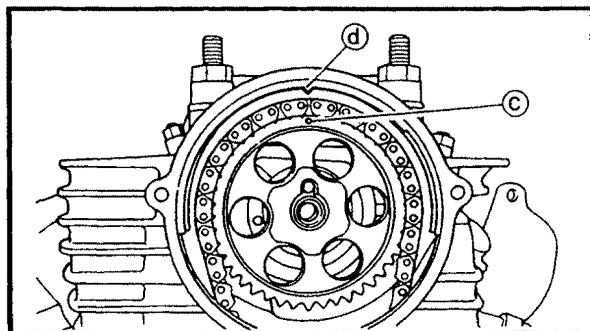

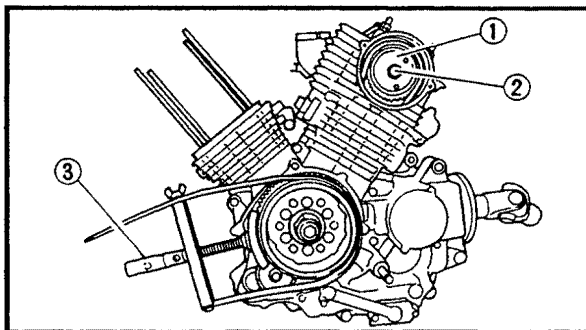
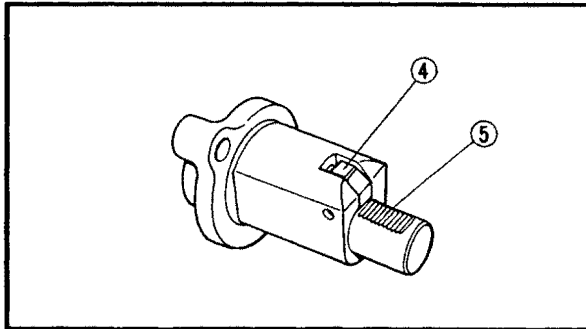
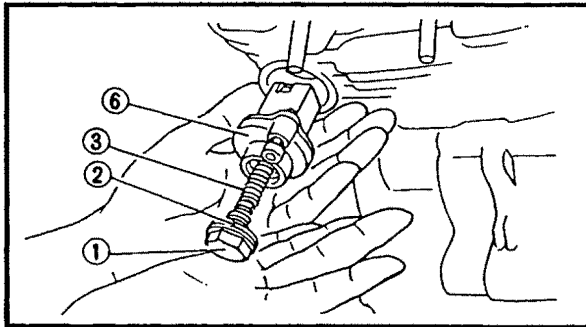

3.Install:

- Timing chain tensioner

Installation steps:

- Remove the tensioner cap bolt ①, washer ② and spring ③.
- Release the timing chain tensioner one-way cam ④ and push the tensioner rod ⑤ all the way in.
- Install the tensioner ⑥ with a new gasket into the cylinder.



Bolts (timing chain tensioner):
12 Nm (1.2 m · kg, 8.7 ft · lb)

⚠ WARNING

Always use a new gasket.

- Install the spring, washer and cap bolt.



Cap bolt (timing chain tensioner):
20 Nm (2.0 m · kg, 14.4 ft · lb)

4.Install:

- Camshaft sprocket plate ①
- Bolt (camshaft sprocket) ②

55 Nm (5.5 m · kg, 39.8 ft · lb)

NOTE:

- Be sure the projection on the camshaft sprocket plate is aligned with the hole in the sprocket.
- Use the sheave holder ③ to hold the rotor.



Sheave holder:
YS-01880, 90890-01701

5.Check:

- Alignment marks
If the marks do not align → Adjust.

6.Measure:

- Valve clearance
Out of specification → Adjust.
Refer to "VALVE CLEARANCE ADJUSTMENT" in CHAPTER 3.



Front cylinder head

NOTE:

When installing the front cylinder head camshafts, repeat the rear cylinder head camshafts installation procedure. However, note the following points.

1. Install:

- Camshaft sprocket

Installation steps:

- Turn the crankshaft clockwise 290°.
- Align the "I" mark ① with the stationary pointer ② on the crankcase cover (left).
- Install the camshaft sprocket with the timing mark ③ facing out.
- Turn the camshaft just enough to remove any slack from the intake side of the timing chain.
- Insert your finger into the hole and timing chain tensioner hole and push the timing chain guide inward.
- While pushing the timing chain guide, be sure that the timing mark ③ and the stationary pointer ④ are properly aligned at TDC.

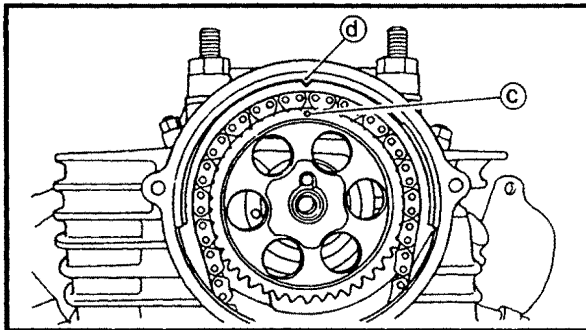
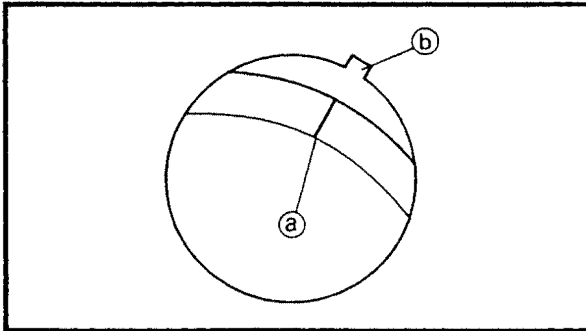

ROCKER ARMS AND CAMSHAFT

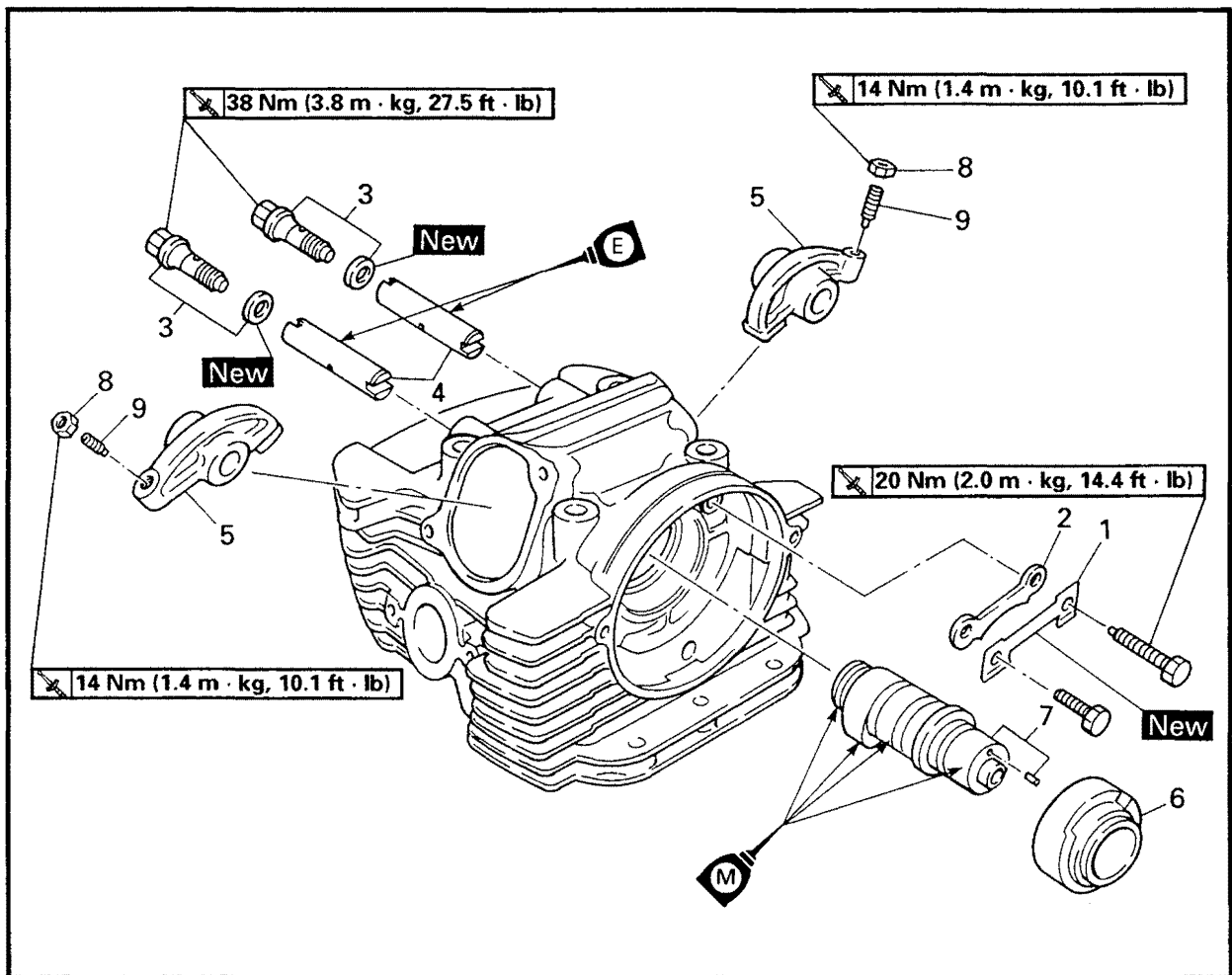

Order	Job name/Part name	Q'ty	Remarks
	Rocker arm and camshaft removal		Remove the parts in the order below. Refer to "CYLINDER HEAD".
	Cylinder heads		
1	Lock washer	1	Refer to "ROCKER ARM AND CAMSHAFT REMOVAL/INSTALLATION".
2	Stopper plate	1	
3	Union bolt/gasket	2/2	
4	Rocker arm shafts	2	
5	Rocker arms	2	
6	Camshaft bushing	1	
7	Camshaft/dowel pin	1/1	
8	Locknuts	2	
9	Valve adjusters	2	
			For installation, reverse the removal procedure.

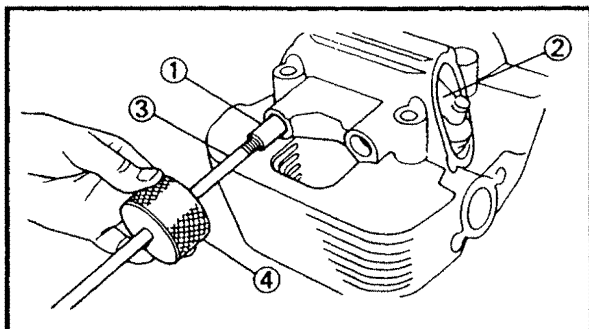

ROCKER ARM AND CAMSHAFT REMOVAL

1.Remove:

- Rocker arm shafts (intake and exhaust) ①
- Rocker arms ②

NOTE:

Use a slide hammer ③ to remove the rocker arm shafts.



Slide hammer bolt (M8):
YU-1083-2, 90890-01085
Weight:
YU-1083-3, 90890-01084

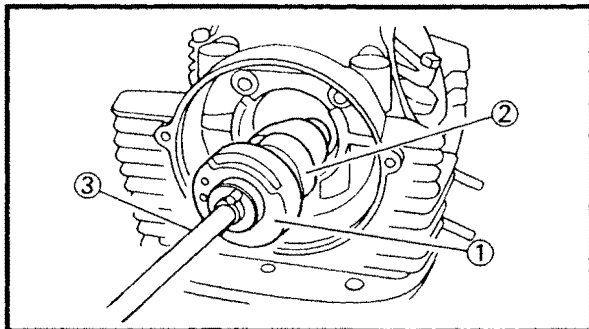

2.Remove:

- Camshaft bushing ①
- Camshaft ②

NOTE:

Screw a 10 mm bolt ③ into the threaded end of the camshaft and pull out the camshaft.

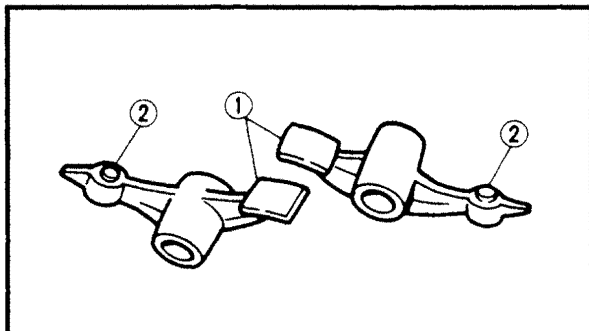

ROCKER ARM AND CAMSHAFT INSPECTION

1.Inspect:

- Camshaft bushings
 Damage/wear → Replace.

2.Inspect:

- Camshaft lobes ①
- Valve adjusters ②
 Blue discoloration/pitting/scratches → Replace.

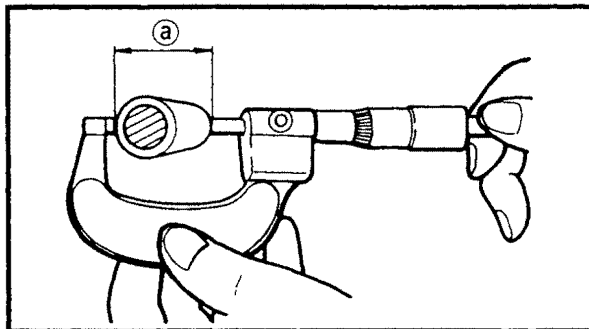

3.Measure:

- Camshaft lobe length ① and width ②
 Out of specification → Replace.

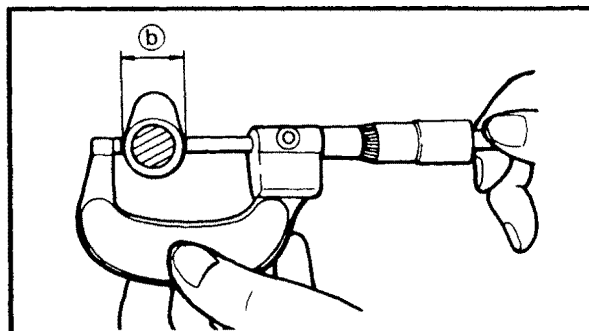

Camshaft lobe limit:

Intake

- ① 39.63 mm (1.56 in)
- ② 32.12 mm (1.265 in)

Exhaust

- ① 39.67 mm (1.562 in)
- ② 32.20 mm (1.268 in)



4. Inspect:

- Rocker arms
 - Rocker arm shafts
- Damage/wear → Replace.

Inspection steps:

- Inspect the two contact areas on the rocker arms for signs of abnormal wear.
 - 1) Rocker arm shaft hole.
 - 2) Camshaft lobe contact surface.

Excessive wear → Replace.
- Inspect the surface of the rocker arm shafts. Blue discoloration/pitting/scratches → Replace/check lubrication.
- Measure the inside diameter (a) of the rocker arm holes. Out of specification → Replace.

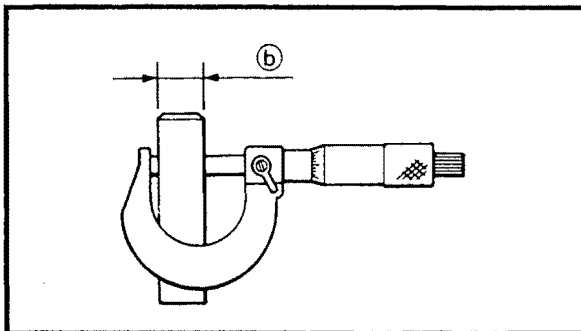
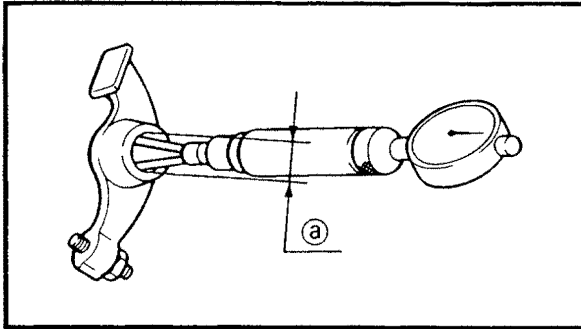

Rocker arm inside diameter:
 14.000 ~ 14.018 mm
 (0.5512 ~ 0.5519 in)

- Measure the outside diameter (b) of the rocker arm shafts. Out of specification → Replace.



Rocker arm outside diameter:
 13.980 ~ 13.991 mm
 (0.5504 ~ 0.5508 in)

- Calculate the clearance by subtracting the rocker arm shaft outside diameter from the rocker arm inside diameter. Clearance greater than 0.08 mm → Replace the defective part(s).



Rocker arm to shaft standard clearance:
 0.009 ~ 0.038 mm
 (0.0035 ~ 0.0015 in)

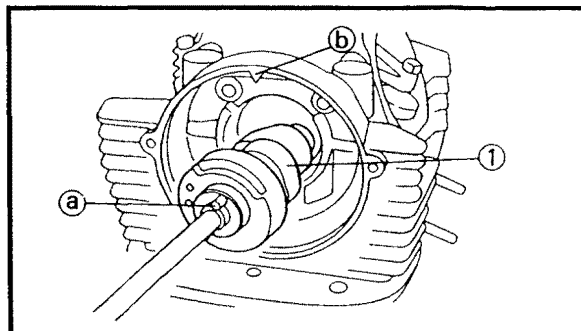

ROCKER ARM AND CAMSHAFT INSTALLATION

1. Apply:
 - Molybdenum disulfide oil (onto the camshaft journals)
2. Install:
 - Camshaft ①
 - Camshaft bushing ②
 - Stopper plate ③
 - Lock washer ④ **New**
 - Bolts (stopper plate) ⑤

20 Nm (2.0 m · kg, 14.4 ft · lb)

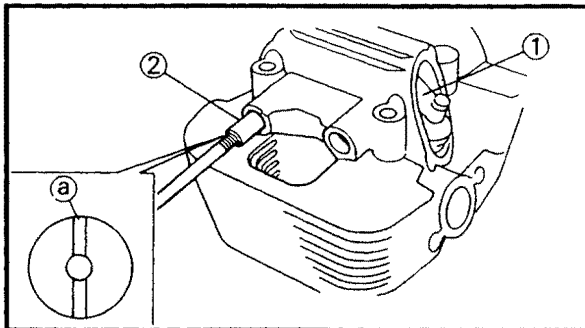
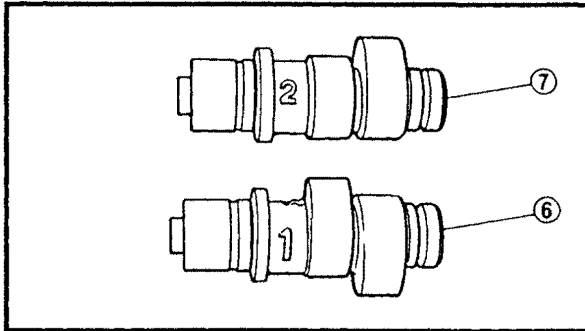
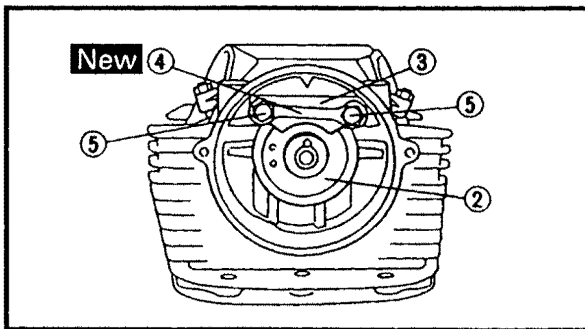

NOTE:

- The dowel pin (a) on the end of the camshaft must align with the timing mark (b) on the cylinder head.
- Make sure that the No.1 camshaft (6) is installed in the rear cylinder head and the No.2 camshaft (7) is installed in the front cylinder head.

3.Apply:

- Engine oil
(onto the rocker arm shafts)

4.Install:

- Rocker arms (1)
- Rocker arm shafts (intake and exhaust) (2)

NOTE:

- The thread hole (a) of the rocker arm shafts must face to the outside.
- After installation, make sure that the thread hole (a) of the rocker arm shaft is positioned correctly, as shown in the illustration.



VALVES AND VALVE SPRINGS

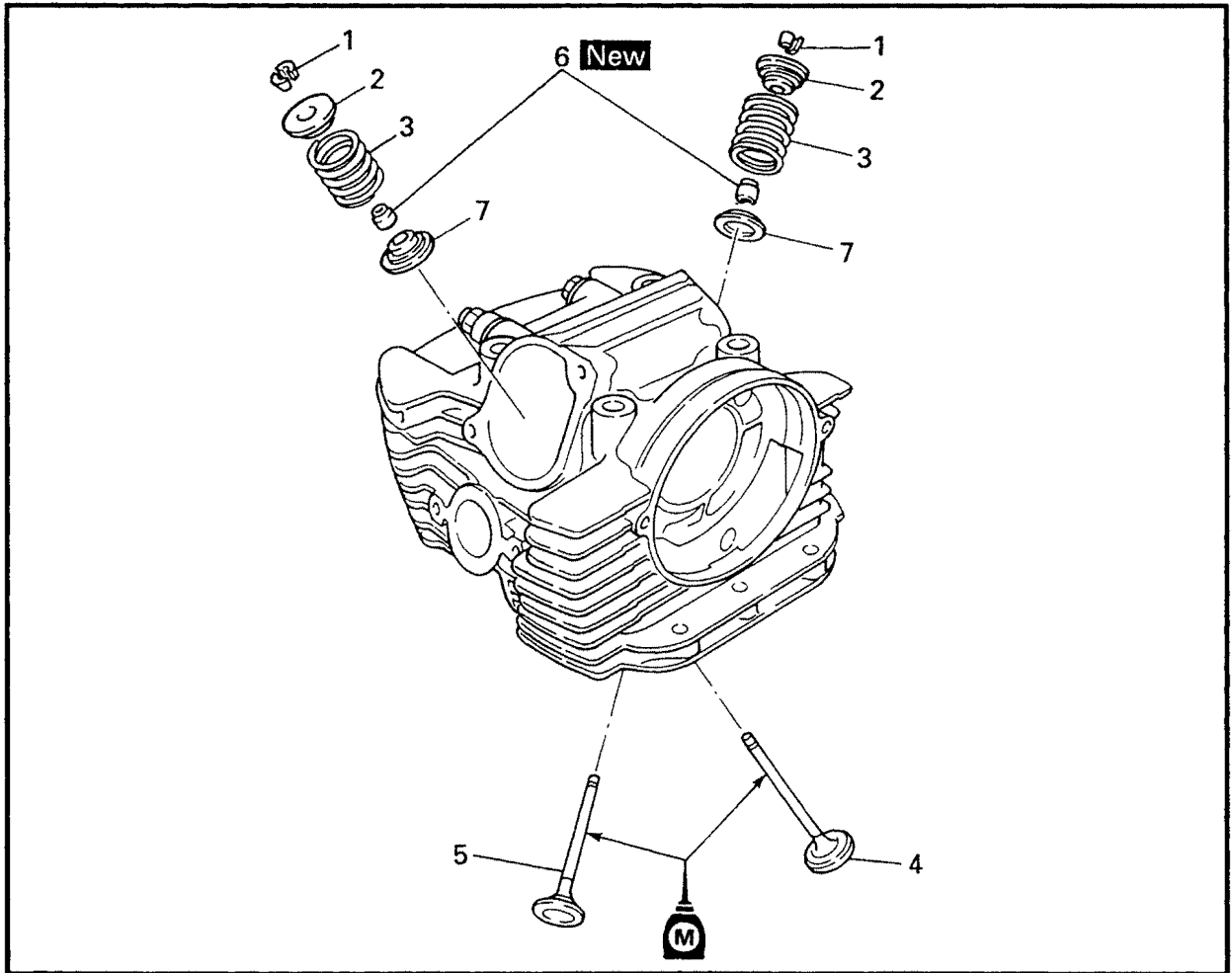

Order	Job name/Part name	Q'ty	Remarks
	Valve and valve spring removal		Remove the parts in the order below.
	Cylinder heads		Refer to "CYLINDER HEADS".
	Rocker arms and camshafts		Refer to "ROCKER ARMS AND CAM-SHAFT".
1	Valve cotters	4	Refer to "VALVE AND VALVE SPRING REMOVAL/INSTALLATION".
2	Valve spring retainers	2	Refer to "VALVE AND VALVE SPRING INSTALLATION".
3	Valve springs	2	
4	Valve (intake)	1	
5	Valve (exhaust)	1	
6	Valve stem seals	2	
7	Valve spring seats	2	

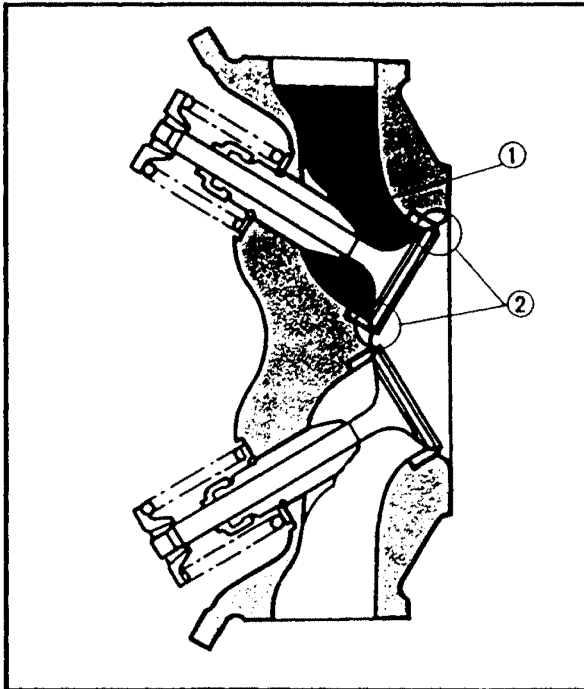

VALVE AND VALVE SPRING REMOVAL

1. Check:

- Valve sealing
Leakage at the valve seat → Inspect the valve face, valve seat and valve seat width.
Refer to "INSPECTION".

Checking steps:

- Pour a clean solvent ① into the intake and exhaust ports.
- Check that the valve seals properly.
There should be no leakage at the valve seat ②.

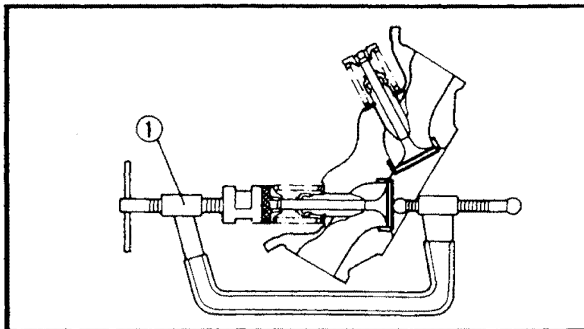

2. Remove:

- Valve cotter

NOTE:

Attach a valve spring compressor ① between the valve spring retainer and the cylinder head to remove the valve cotter.



Valve spring compressor:
YM-04019, 90890-04019

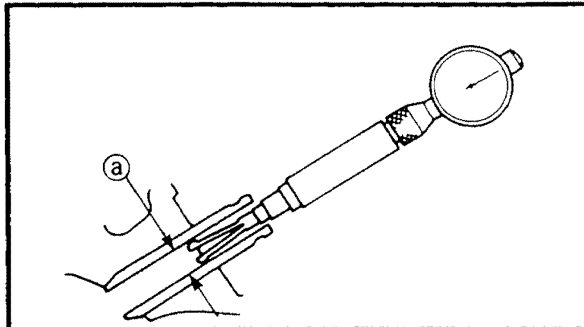

VALVE AND VALVE SPRING INSPECTION

1. Measure:

- Stem-to-guide clearance

Stem-to-guide clearance =
valve guide inside diameter ① -
valve stem diameter ②

Out of specification → Replace the valve guide.

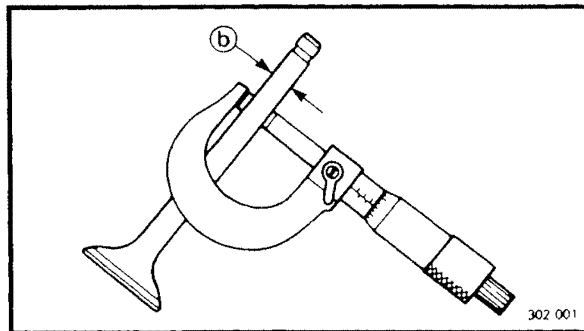

Clearance (stem to guide):

Intake:

0.010 ~ 0.037 mm
(0.0004 ~ 0.015 in)
<Limit>: 0.08 mm (0.003 in)

Exhaust:

0.025 ~ 0.052 mm
(0.001 ~ 0.002 in)
<Limit>: 0.10 mm (0.004 in)

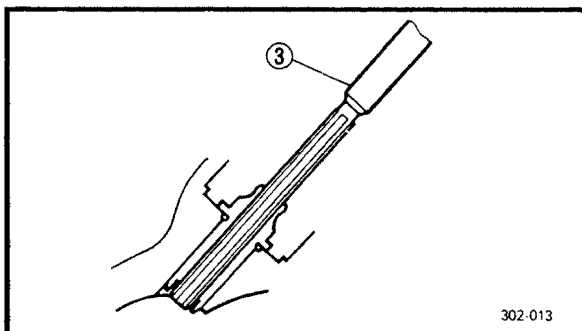
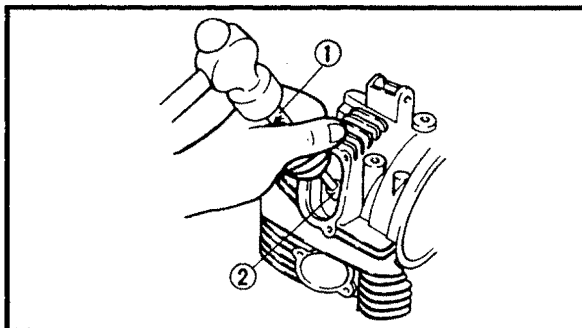
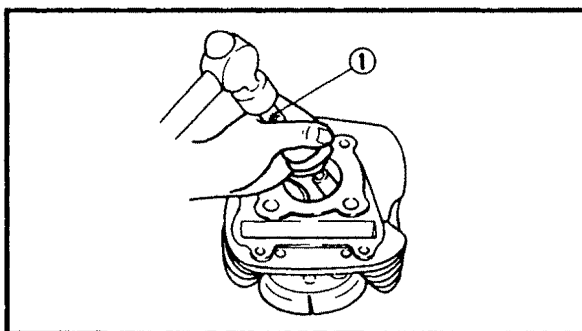

302-013

2. Replace:

- Valve guide

Replacement steps:

NOTE:

To ease guide removal, installation and to maintain correct fit heat the cylinder head in an oven to 100°C.

- Remove the valve guide using a valve guide remover (1).
- Install the new valve guide using a valve guide remover (1) and valve guide installer (2).
- After installing the valve guide, bore the valve guide using a valve guide reamer (3) to obtain proper stem-to-guide clearance.



Valve guide remover & installer (7.0 mm (0.28 in)):
 Remover YM-01225-A,
 Reamer YM-0127,
 Installer YM-04017,
 90890-04018

NOTE:

After replacing the valve guide reface the valve seat.

3. Inspect:

- Valve face
Pitting/wear → Grind the face.
- Valve stem end
Mushroom shape or diameter larger than the body of the stem → Replace.

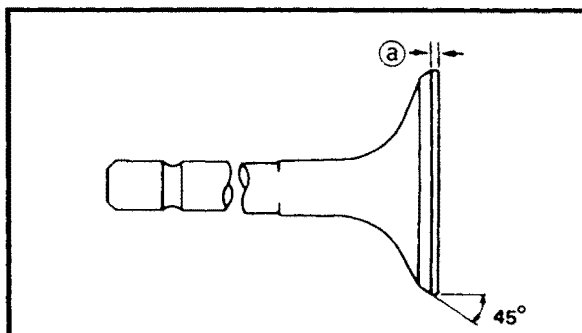

4. Measure:

- Margin thickness (a)
Out of specification → Replace.



Margin thickness:
Intake:
 1.0 ~ 1.4 mm (0.039 ~ 0.055 in)
 <Limit>: 0.8 mm (0.031 in)
Exhaust:
 1.0 ~ 1.4 mm (0.039 ~ 0.055 in)
 <Limit>: 0.8 mm (0.031 in)

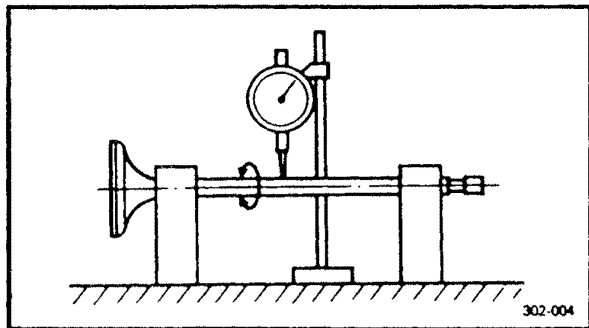

5.Measure:

- Runout (valve stem)
Out of specification → Replace.



Runout limit:
0.03 mm (0.001 in)

NOTE:

- When installing a new valve always replace the guide.
- If the valve is removed or replaced always replace the oil seal.

6.Eliminate:

- Carbon deposits
(from the valve face and valve seat)

7.Inspect:

- Valve seats
Pitting/wear → Reface the valve seat.

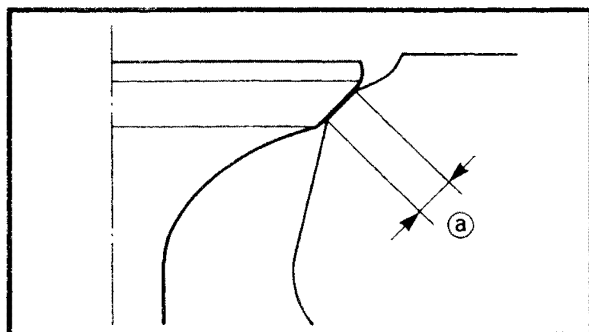

8.Measure:

- Valve seat width ①
Out of specification → Reface the valve seat.



Valve seat width:
Intake:
1.0 ~ 1.2 mm (0.039 ~ 0.047 in)
<Limit>: 1.8 mm (0.071 in)
Exhaust:
1.0 ~ 1.2 mm (0.039 ~ 0.047 in)
<Limit>: 1.8 mm (0.071 in)

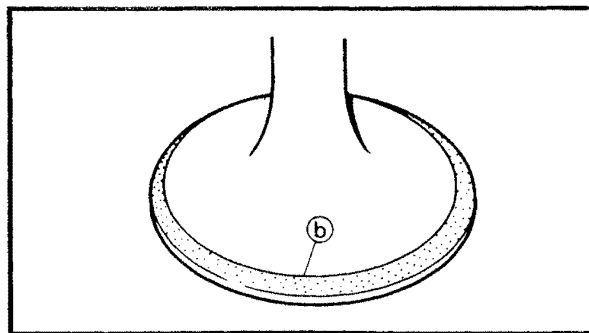

Measurement steps:

- Apply Mechanic's blueing dye (Dykem) ② to the valve face.
- Install the valve into the cylinder head.
- Press the valve through the valve guide and onto the valve seat to make a clear pattern.
- Measure the valve seat width. Where the valve seat and valve face made contact, blueing will have been removed.
- If the valve seat is too wide, too narrow, or the seat is not centered, the valve seat must be refaced.



9.Lap:

- Valve face
- Valve seat

NOTE:

After refacing the valve seat or replacing the valve and valve guide, the valve seat and valve face should be lapped.

Lapping steps:

- Apply a coarse lapping compound to the valve face.

CAUTION:

Do not let the compound enter the gap between the valve stem and the guide.

- Apply molybdenum disulfide oil to the valve stem.
- Install the valve into the cylinder head.
- Turn the valve until the valve face and valve seat are evenly polished, then clean off all of the compound.

NOTE:

For best lapping results, lightly tap the valve seat while rotating the valve back and forth between your hands.

- Apply a fine lapping compound to the valve face and repeat the above steps.

NOTE:

After every lapping operation be sure to clean off all of the compound from the valve face and valve seat.

- Apply Mechanic's blueing dye (Dykem) to the valve face.
- Install the valve into the cylinder head.
- Press the valve through the valve guide and onto the valve seat to make a clear pattern.
- Measure the valve seat width again. If the valve seat width is out of specification, reface and relap the valve seat.

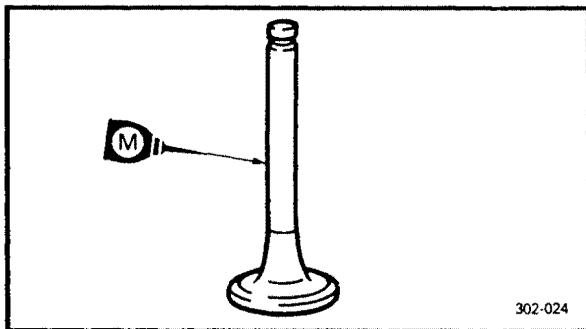
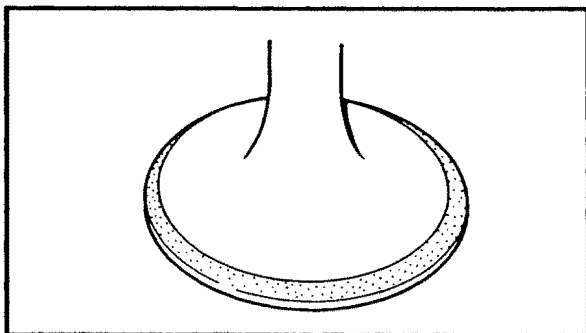

302-024

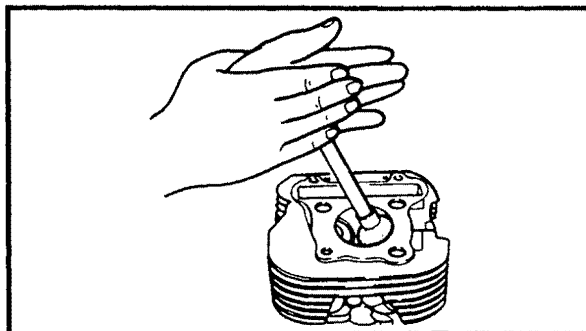

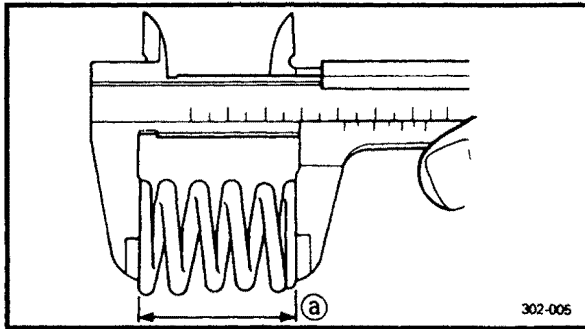

10.Measure:

- Valve spring free length ①
Out of specification → Replace.



Free length (valve spring):
43.2 mm (1.70 in)
<Limit>: 42.0 mm (1.65 in)

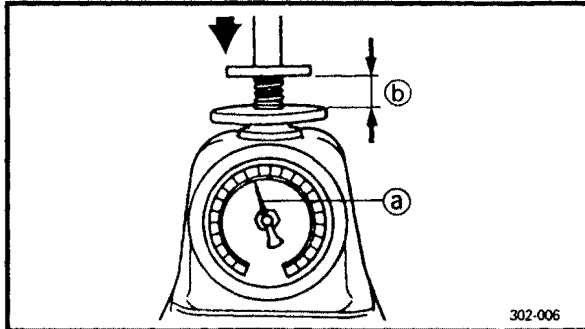

11.Measure:

- Compressed spring force ①
Out of specification → Replace.
- ② Installed length



Compressed spring force:
21.8 ~ 25.6 kg at 37.1 mm
(48.1 ~ 56.4 lb at 1.46 in)

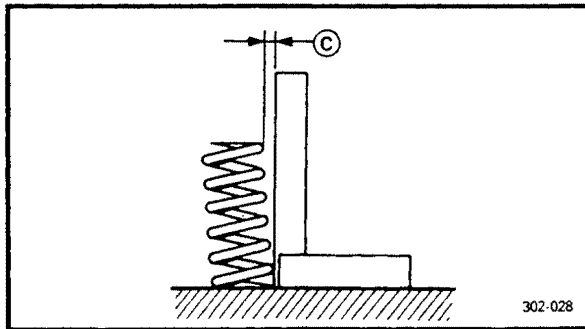

12.Measure:

- Spring tilt ①
Out of specification → Replace.



Spring tilt limit:
2.5°/1.9 mm (0.074 in)

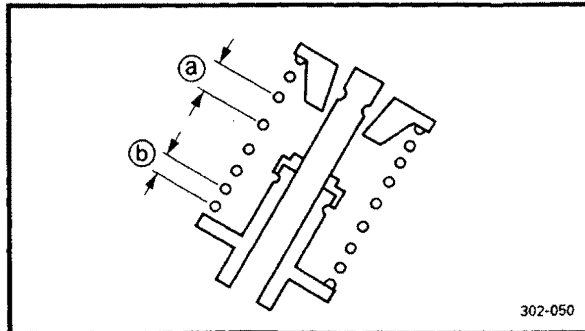

VALVE AND VALVE SPRING INSTALLATION

1.Apply:

- Molybdenum disulfide oil
(onto the valve stem and valve stem seal)

2.Install:

- Valve spring seats
- Valve stem seals **New**
- Valves
- Valve springs
- Valve spring retainers

NOTE:

Install the valve springs with the larger pitch ① facing upwards.

② Smaller pitch

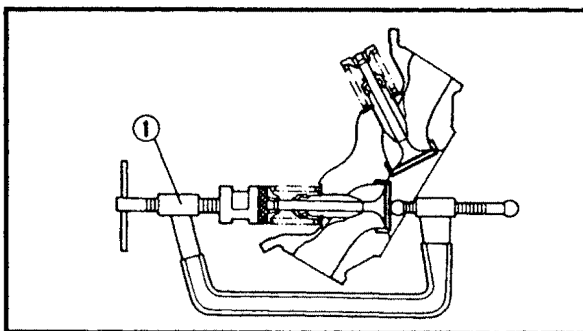

3. Install:

- Valve cotters

NOTE:

While compressing the valve spring with a valve spring compressor ① install the valve cotters.



Valve spring compressor:
YM-04019, 90890-04019

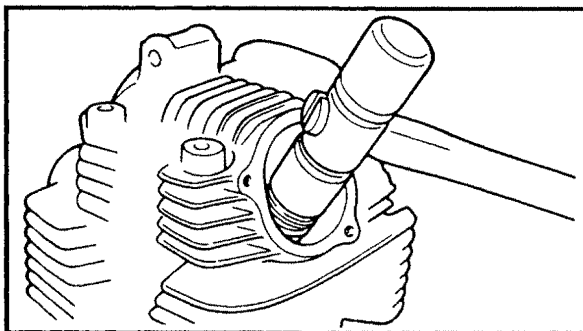

4. To secure the valve cotters onto the valve stem lightly tap the valve tip with a piece of wood.

CAUTION:

Hitting the valve tip with excessive force could damage the valve.

CYLINDERS AND PISTONS

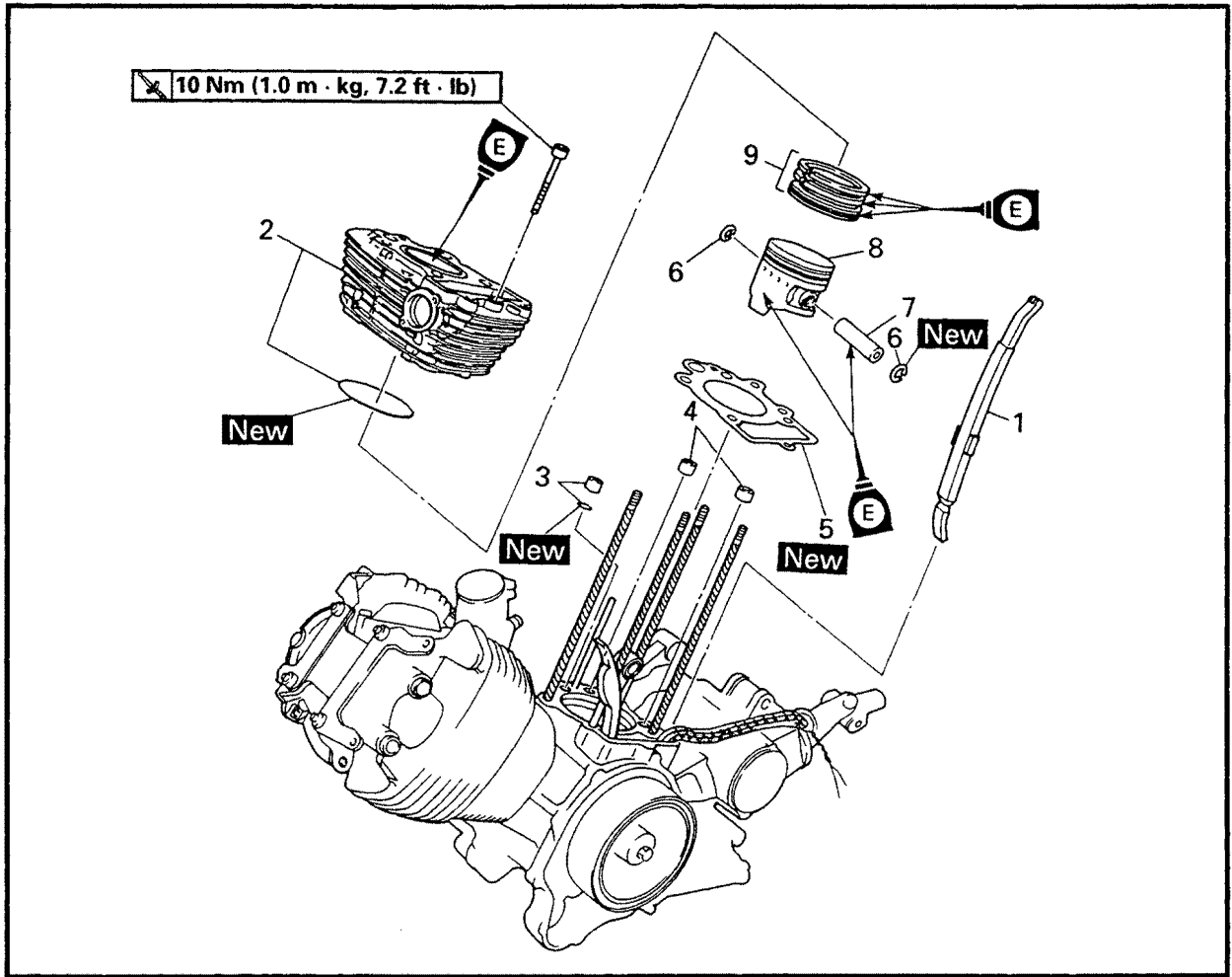

Order	Job name/Part name	Q'ty	Remarks
	Cylinder and piston removal		Remove the parts in the order below.
	Cylinder heads		Refer to "CYLINDER HEADS".
1	Timing chain guide	1	The "up" mark should face towards the cylinder head.
2	Cylinder/O-ring	1/1	Refer to "CYLINDER AND PISTON INSTALLATION".
3	O-ring/collar	1/1	
4	Dowel pins	2	
5	Cylinder gasket	1	
6	Piston pin clips	2	Refer to "PISTON REMOVAL/CYLINDER AND PISTON INSTALLATION".
7	Piston pin	1	
8	Piston	1	
9	Piston ring set	1	For installation, reverse the removal procedure.

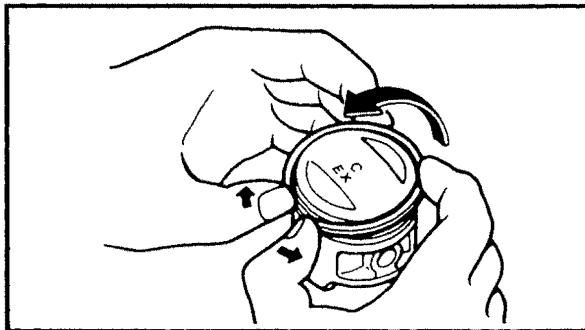
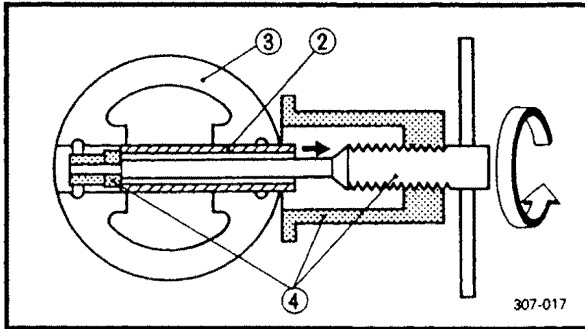
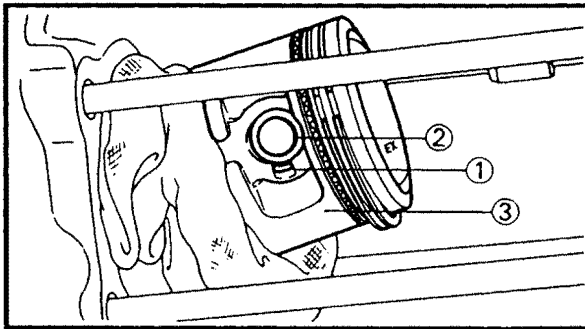

PISTON REMOVAL

1.Remove:

- Piston pin clips ①
- Piston pin ②
- Piston ③

NOTE:

- Put identification marks on each piston head for reference during reinstallation.
- Before removing each piston pin, deburr the clip groove and pin hole area. If the piston pin groove is deburred and the piston pin is still difficult to remove, use the piston pin puller ④.

	<p>Piston pin puller: YU-01304, 90890-01304</p>
--	--

CAUTION:

Do not use a hammer to drive the piston pin out.

2.Remove:

- Piston rings

NOTE:

Spread the end gaps apart while at the same time lifting the piston ring over the top of the piston crown, as shown in the illustration.

CYLINDER AND PISTON INSPECTION

1.Inspect:

- Cylinder and piston walls
Vertical scratches → Rebore or replace the cylinder and the piston.

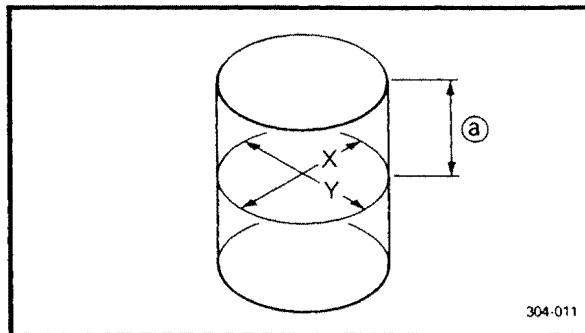

2.Measure:

- Piston-to-cylinder clearance

Measurement steps:

1st step:

- Measure the cylinder bore "C" with a cylinder bore gauge.
- ① 40 mm from the top of the cylinder

NOTE: _____
 Measure the cylinder bore "C" horizontally and laterally.

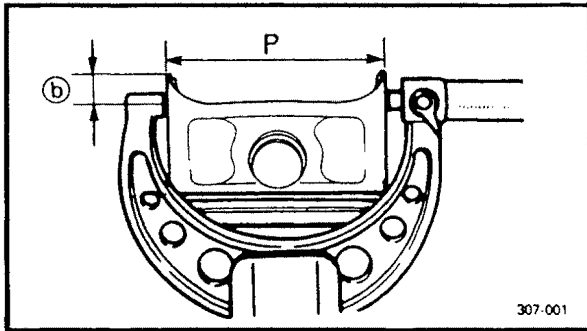

	Standard	Wear limit
Cylinder bore C:	80.965 ~ 81.015 mm (3.188 ~ 3.190 in)	81.1 mm (3.193 in)
$C = \frac{X + Y}{2}$		

- Find the average of the measurements.
- If out of specification, rebore or replace the cylinder and replace the piston and piston rings as a set.

2nd step:

- Measure the piston skirt diameter "P" with a micrometer.
- Ⓟ 6 mm from the piston bottom edge.

	Piston size P
Standard	80.92 ~ 80.97 mm (3.186 ~ 3.188 in)

- If out of specification, replace the piston and the piston rings as a set.

3rd step:

- Use the following formula to calculate the piston-to-cylinder clearance:

<p>Piston-to-cylinder clearance = Cylinder bore "C" – Piston skirt diameter "P"</p>
--

	Clearance (piston to cylinder):
	0.035 ~ 0.055 mm (0.0013 ~ 0.0022 in)
	<Limit>: 0.15 mm (0.006 in)

- If out of specification, rebore or replace the cylinder and replace the piston and the piston rings as a set.

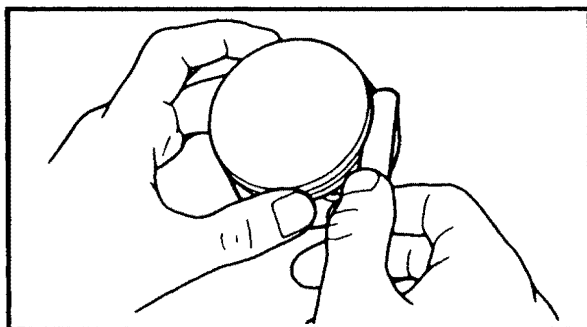

PISTON RING INSPECTION

1.Measure:

- Side clearance (piston to piston rings)
Out of specification → Replace the piston and the piston rings as a set.

NOTE:

Before measuring the side clearance remove the carbon deposits from the piston ring grooves and rings.



Side clearance (piston ring):

Top ring:

0.03 ~ 0.07 mm
(0.001 ~ 0.003 in)

<Limit>: 0.12 mm (0.005 in)

2nd ring:

0.02 ~ 0.06 mm
(0.0008 ~ 0.0024 in)

<Limit>: 0.12 mm (0.0047 in)

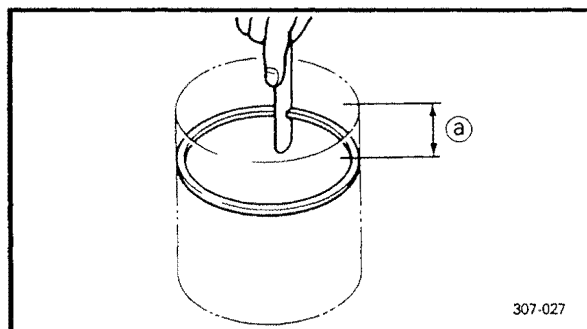

307-027

2.Position:

- Piston ring
(into the cylinder)

NOTE:

Using the piston crown push the ring into the cylinder so that the ring will be at a right angle to the cylinder bore.

Ⓐ 40 mm (1.57 in)

3.Measure:

- End gap
Out of specification → Replace.

NOTE:

You cannot measure the end gap on the expander spacer of the oil ring. If the oil ring rails show excessive gap, replace all three rings.



End gap:

Top ring:

0.15 ~ 0.30 mm
(0.006 ~ 0.012 in)

<Limit>: 0.55 mm (0.022 in)

2nd ring:

0.30 ~ 0.45 mm
(0.012 ~ 0.018 in)

<Limit>: 0.80 mm (0.003 in)

Oil ring:

0.2 ~ 0.7 mm (0.008 ~ 0.028 in)

PISTON PIN INSPECTION

1. Inspect:

- Piston pin
Blue discoloration/grooves → Replace, then inspect the lubrication system.

2. Measure:

- Piston pin-to-piston clearance

Measurement steps:

- Measure the piston pin outside diameter (a).

If out of specification, replace the piston pin.

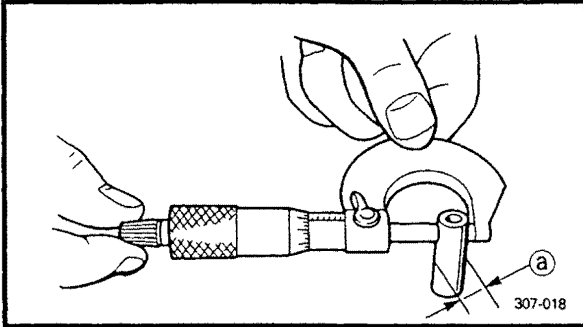



	Outside diameter (piston pin): 19.995 ~ 20.000 mm (0.7872 ~ 0.7874 in)
---	---

- Measure the piston inside diameter (b).
- Calculate the piston pin-to-piston clearance using the following formula:

Piston pin-to-piston clearance = Bore size (piston pins) (b) - Outside diameter (piston pins) (a)	
--	--

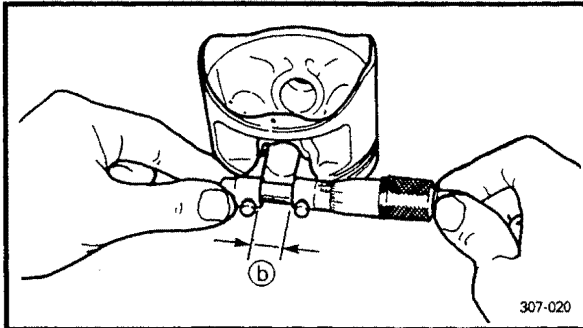
- If out of specification, replace the piston.



	Clearance (piston pin to piston): 0.004 ~ 0.020 mm (0.00016 ~ 0.0008 in)
---	---

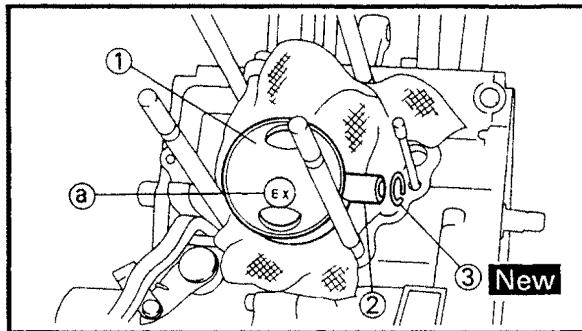
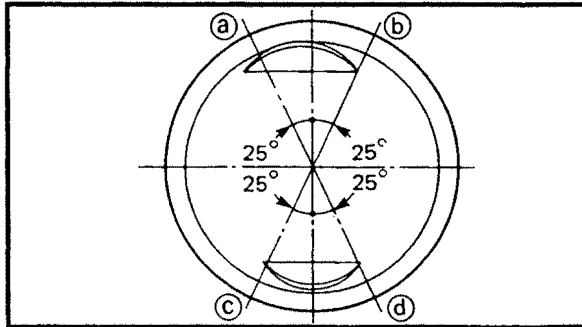
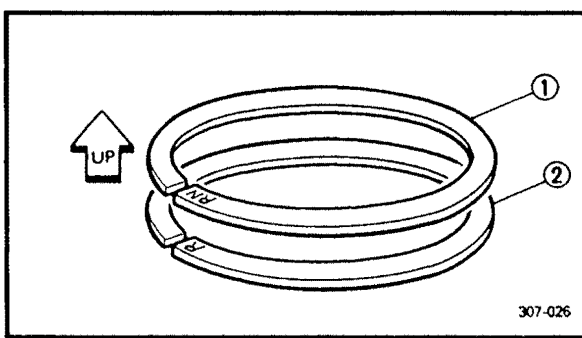

CYLINDER AND PISTON INSTALLATION

1.Install:

- Piston ring (top ring) ①
- Piston ring (second ring) ②

NOTE:

- Be sure to install the piston rings so that the manufacturer's marks or numbers are located on the upper side of the rings.
- Lubricate the piston and piston rings liberally with engine oil.

2.Position:

- Top ring ①
 - 2nd ring ②
 - Oil ring ③
- Offset the piston ring end gaps as shown.
- ① Top ring end
 - ② Oil ring end (lower)
 - ③ Oil ring end (upper)
 - ④ 2nd ring end

3.Install:

- Piston ①
- Piston pin ②
- Piston pin clips ③ **New**

NOTE:

- Apply engine oil onto the piston pin, piston ring and piston.
- Be sure that the piston is positioned correctly, as shown in the illustration.

① "EX" mark

4.Lubricate:

- Piston
- Piston rings
- Cylinder

NOTE:

Apply a liberal coating of engine oil.

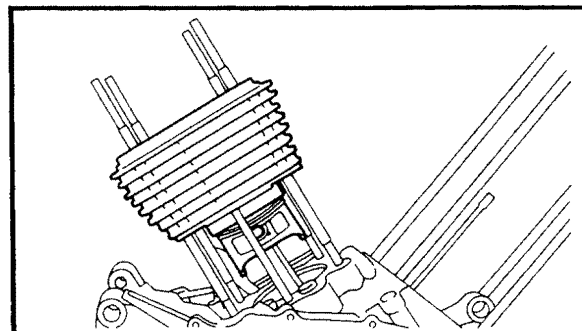

5.Install:

- Cylinder

NOTE:

Install the cylinder with one hand while compressing the piston rings with the other hand.



CLUTCH

CRANKCASE COVER (RIGHT)

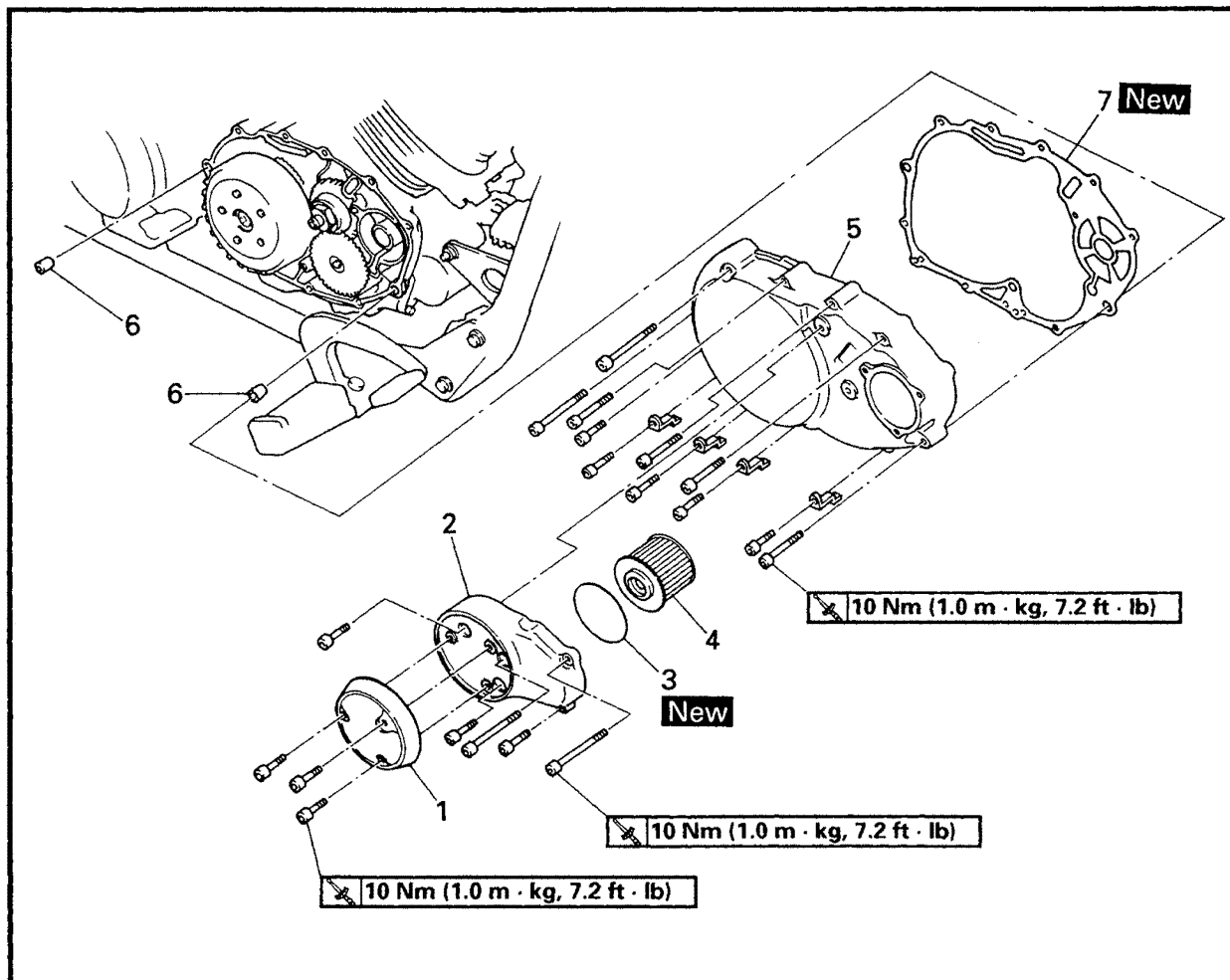

Order	Job name/Part name	Q'ty	Remarks
	Crankcase cover (right) removal		Remove the parts in the order below. Stand the motorcycle on a level surface.
	Engine oil		⚠ WARNING Securely support the motorcycle so there is no danger of it falling over.
	Muffler assembly 1,2		Refer to "ENGINE OIL REPLACEMENT" in CHAPTER 3.
	Brake pedal link		Refer to "ENGINE REMOVAL".
1	Oil filter cover plate	1	
2	Oil filter cover	1	L=70 mm × 1, 65 mm × 1, 25 mm × 3 (2.76 in × 0.065 in × 0.049 in × 3)
3	O-ring	1	
4	Oil filter	1	
5	Crankcase cover (right)	1	L=65 mm × 1, 55 mm × 1, 45 mm × 4, 30 mm × 4 (2.56 in × 0.061 in × 0.057 in × 4, 1.18 in × 4)

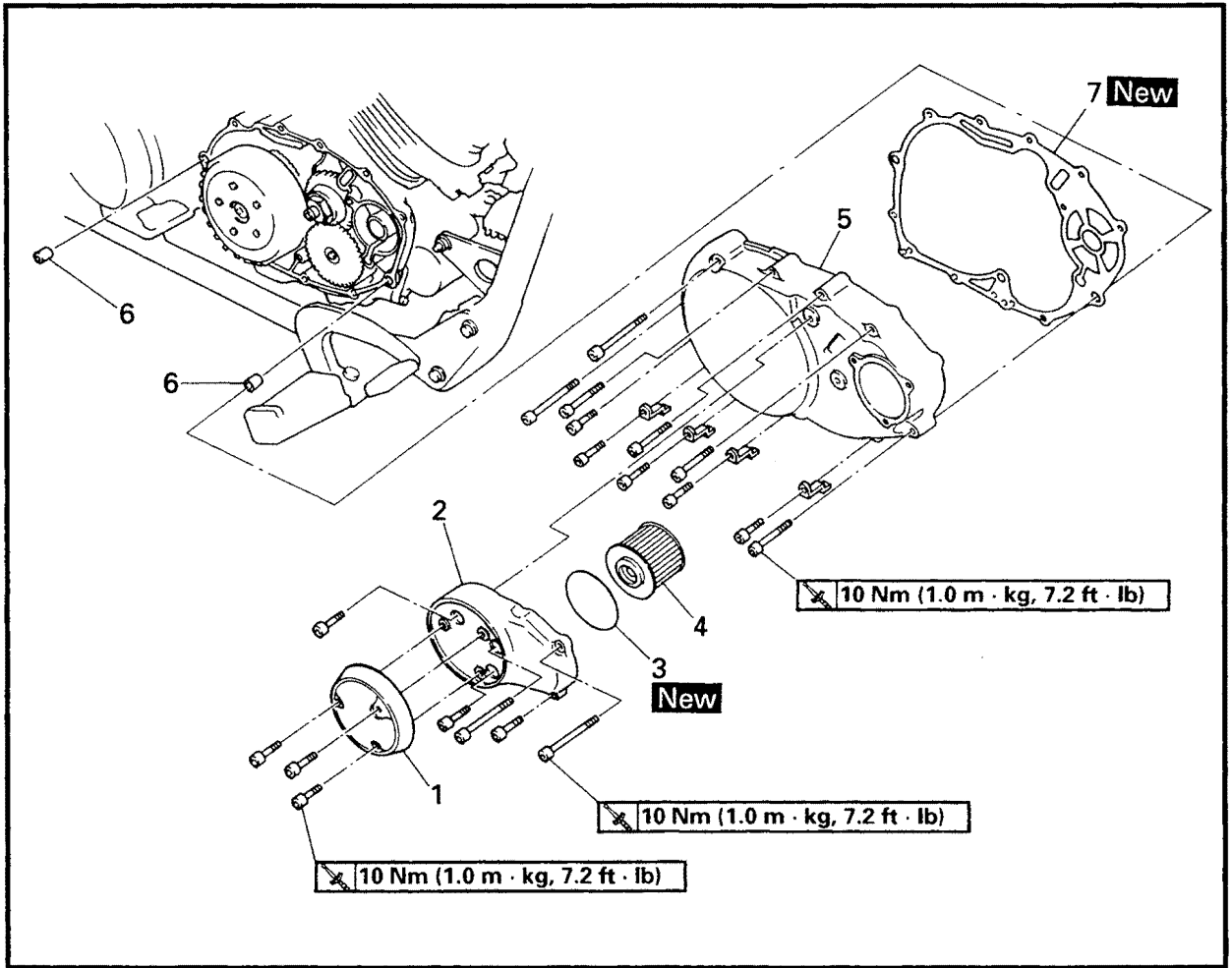

Order	Job name/Part name	Q'ty	Remarks
6	Dowel pins	2	For installation, reverse the removal procedure.
7	Crankcase cover gasket	1	



CLUTCH ASSEMBLY

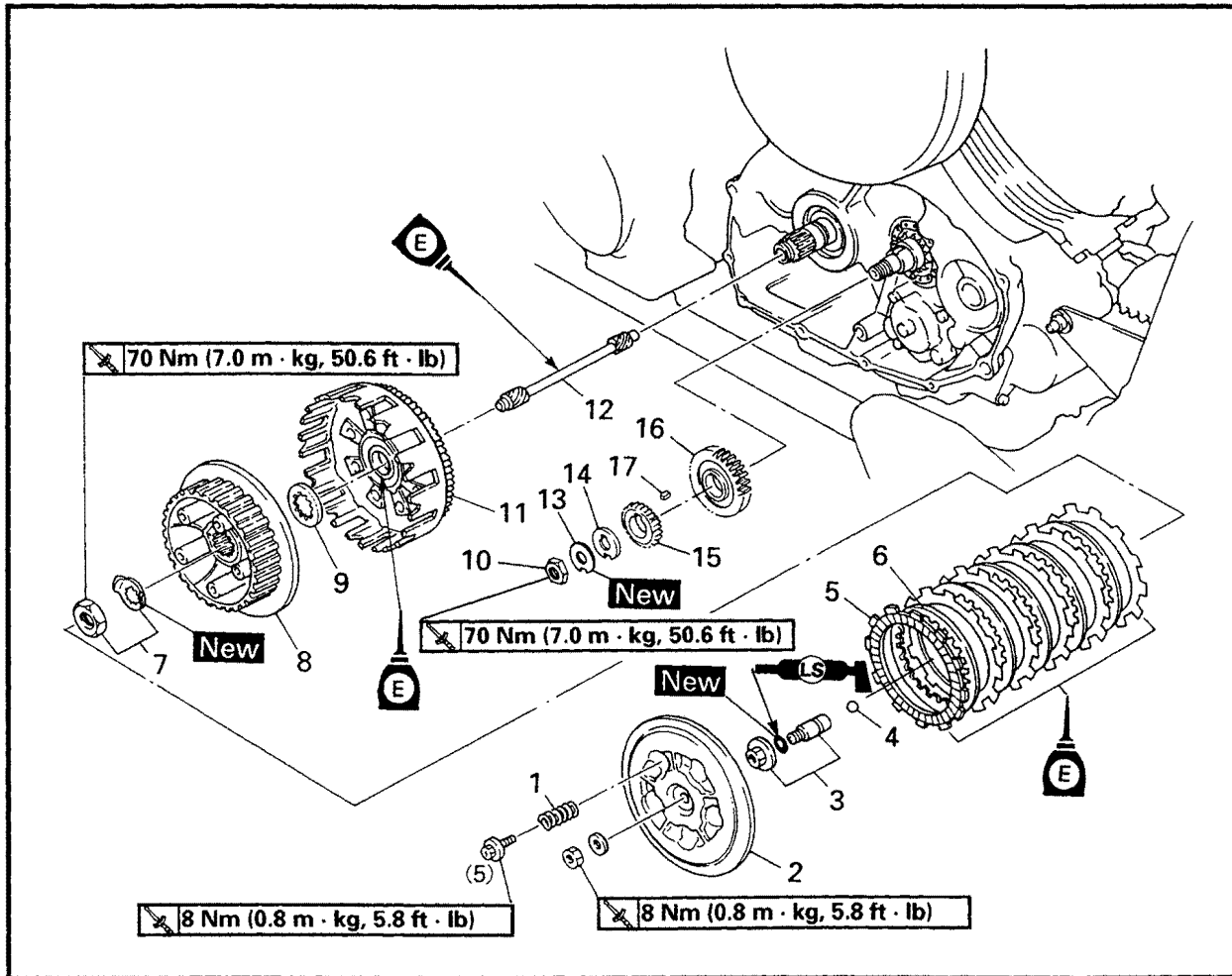

Order	Job name/Part name	Q'ty	Remarks
	Clutch assembly removal		Remove the parts in the order below. Refer to "OIL PUMP".
1	Oil pump driven gear		
1	Clutch springs	5	
2	Pressure plate	1	
3	Push plate/push rod #1	1/1	Refer to "CLUTCH INSTALLATION".
4	Ball	1	
5	Friction plates	6	
6	Clutch plates	5	
7	Nut/locknut	1/1	Refer to "CLUTCH REMOVAL/INSTALLATION".
8	Clutch boss	1	
9	Thrust washer	1	
10	Nut (primary drive gear)	1	Refer to "PRIMARY DRIVE GEAR REMOVAL/INSTALLATION".
11	Clutch housing	1	
12	Push rod #2	1	Refer to "INSTALLATION".

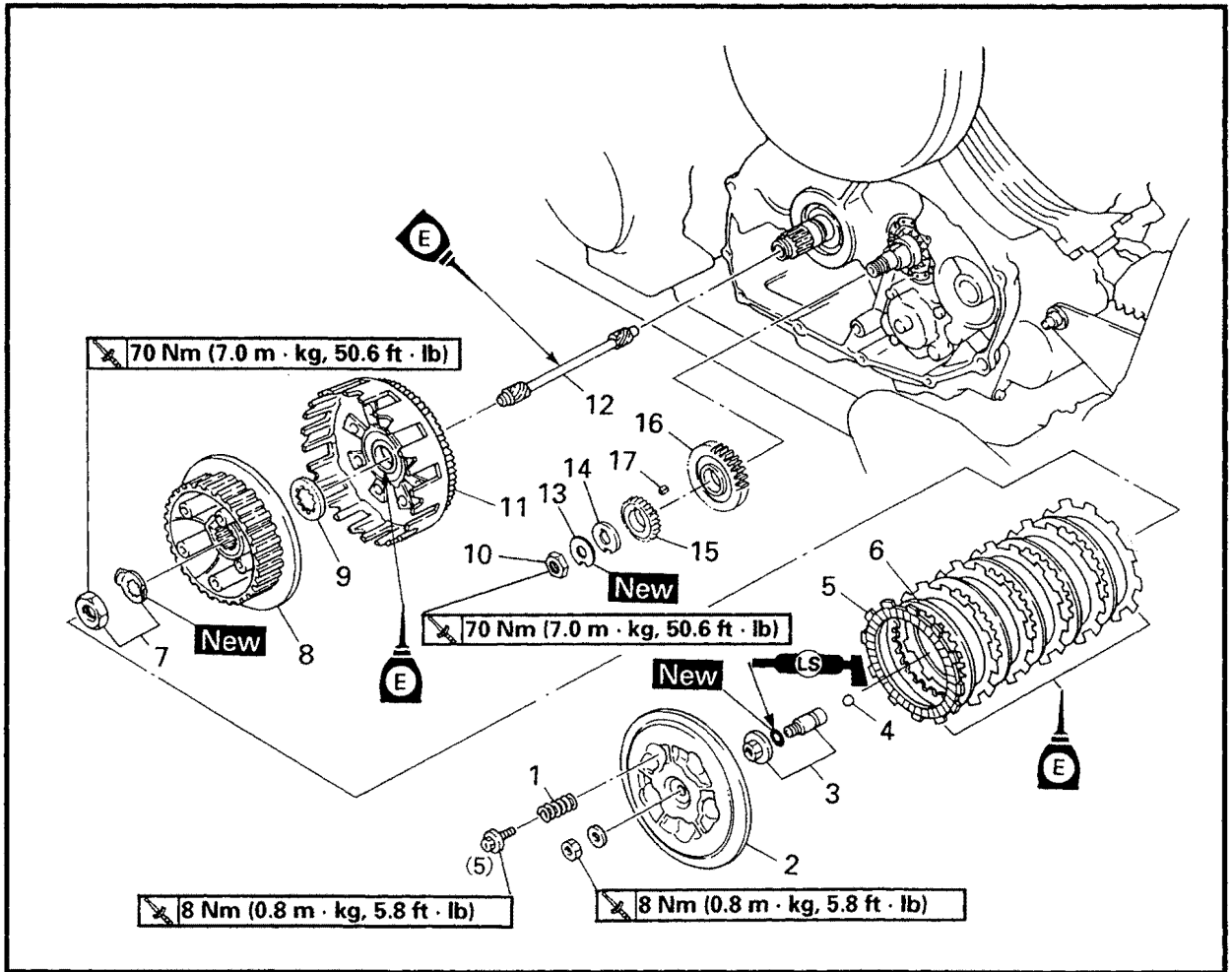

Order	Job name/Part name	Q'ty	Remarks
13	Lock washer	1	
14	Claw washer	1	
15	Drive gear (oil pump)	1	
16	Primary drive gear	1	
17	Straight key	1	
			For installation, reverse the removal procedure.

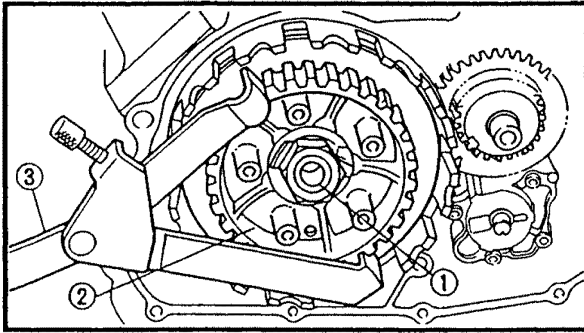
**CLUTCH REMOVAL**

1. Straighten:

- Lock washer tab

2. Loosen:

- Nut (clutch boss) ①

NOTE:

Loosen the nut (clutch boss) ① while holding the clutch boss ② with the clutch holding tool ③.

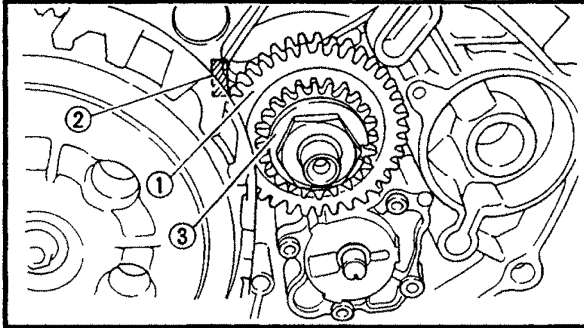

Clutch holding tool:
YM-91042, 90890-04086

**PRIMARY DRIVE GEAR REMOVAL**

1. Straighten:

- Lock washer tab

2. Loosen:

- Nut (primary drive gear) ①

NOTE:

Place a copper plate ② between the teeth of the primary drive gear ③ and primary driven gear to lock them.

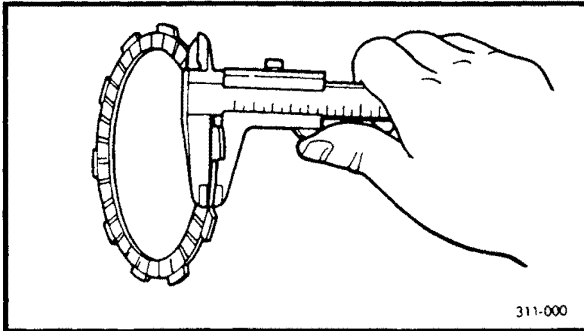

311-000

CLUTCH INSPECTION

1. Inspect:

- Friction plates
Wear/damage → Replace the friction plates as a set.

2. Measure:

- Friction plate thickness
Out of specification → Replace the friction plates as a set.
Measure at four places.



Thickness (friction plate):
2.9 ~ 3.1 mm (0.114 ~ 0.122 in)
<Wear limit>: 2.6 mm (0.102 in)

3. Inspect:

- Clutch plate
Damage → Replace the clutch plates as a set.

4. Measure:

- Clutch plate warpage
Out of specification → Replace the clutch plates as a set.
Use a surface plate and a feeler gauge ①.

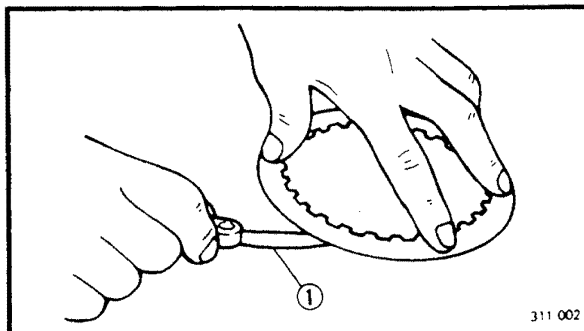

311 002



Warp limit (clutch plate):
Less than 0.2 mm (0.008 in)



5. Inspect:

- Primary drive gear teeth
Wear/damage → Replace the clutch housing.

6. Check:

- Circumferential play
Free play → Replace the clutch housing.

7. Inspect:

- Clutch spring
Damage → Replace the clutch spring.

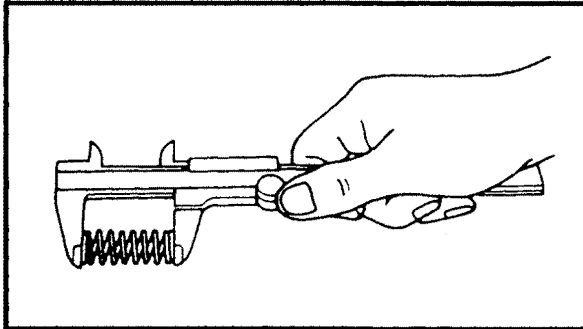

8. Measure:

- Clutch spring free length
Out of specification → Replace the clutch springs as a set.



Free length (clutch spring):

39.5 mm (1.555 in)

<Wear limit>: 38.5 mm (1.516 in)

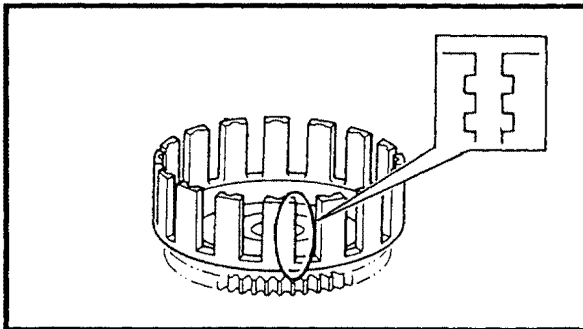

9. Inspect:

- Dogs (on the clutch housing)
Pitting/wear/damage → Deburr or replace.
- Clutch housing bearing
Wear/damage → Replace the clutch housing.

NOTE:

Pitting on the clutch housing dogs will cause erratic operation.

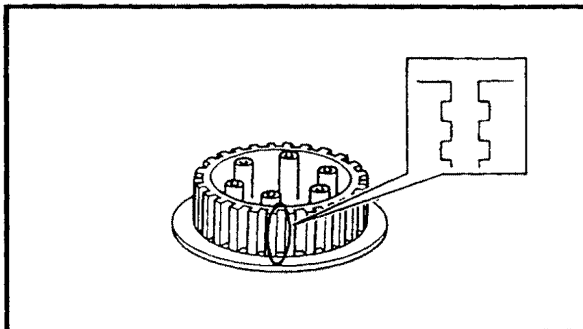

10. Inspect:

- Clutch boss splines
Pitting/wear/damage → Replace the clutch boss.

NOTE:

Pitting on the clutch boss splines will cause erratic operation.

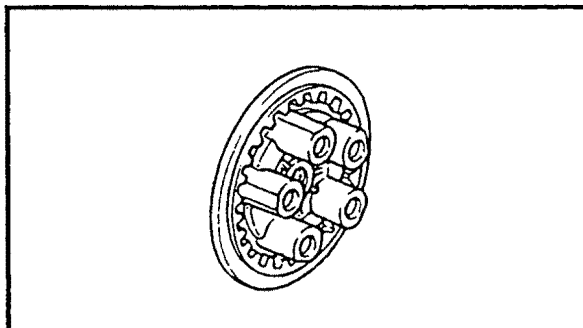

11. Inspect:

- Pressure plate
Cracks/damage → Replace.

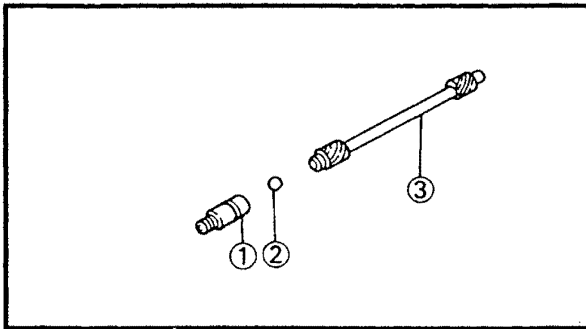

PUSH ROD INSPECTION

1. Inspect:

- Push rod #1 ①
 - O-ring **New**
 - Ball ②
 - Push rod #2 ③
- Cracks/wear/damage → Replace.

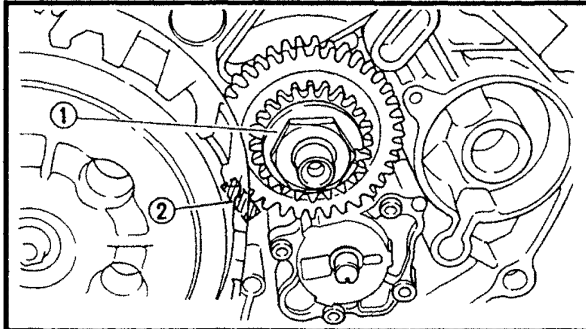

PRIMARY DRIVE GEAR INSTALLATION

1. Install:

- Drive gear (oil pump) ①
- Claw washer
- Lock washer **New**
- Nut (primary drive gear)

70 Nm (7.0 m · kg, 50.6 ft · lb)

NOTE:

- Place a copper plate ② between the teeth of the primary drive gear ③ and primary driven gear to lock them.

2. Bend:

- Lock washer tab (along a flat side of the nut)

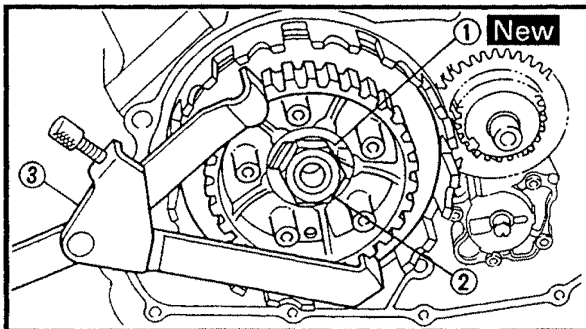

CLUTCH INSTALLATION

1. Install:

- Lock washer ① **New**
- Nut (clutch boss) ②

70 Nm (7.0 m · kg, 50.6 ft · lb)

NOTE:

Tighten the nut (clutch boss) ② while holding the clutch boss with a clutch holding tool ③.



**Clutch holding tool:
YM-91042, 90890-04086**

2. Bend:

- Lock washer tab (along a flat side of the nut)

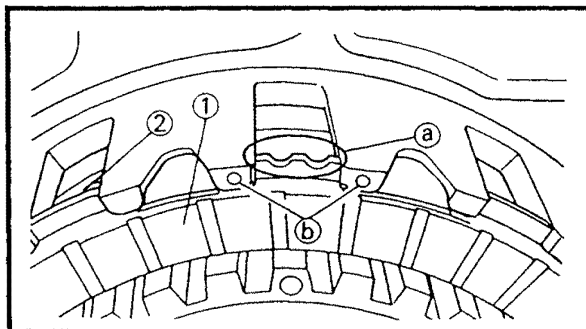

3. Install:

- Friction plates ①
- Clutch plates ②

Installation steps:

- Install one friction plate and one clutch plate alternately.



NOTE:

- Apply engine oil onto the friction plates.
- Align the two slots (a) on the friction plates with the two punch marks (b) on the clutch housing.

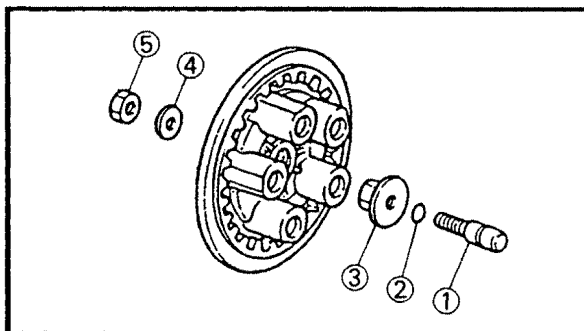

4.Install:

- Push rod #2
- Ball
- Push rod #1 (1)
- O-ring (2) **New**
- Push plate (3)
- Washer (4)
- Nut (5)

NOTE:

Apply lithium soap base grease onto the push rod and the ball.

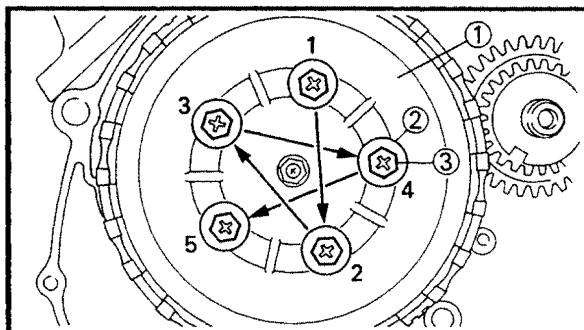

5.Install:

- Pressure plate (1)
- Clutch springs (2)
- Bolts (3) **8 Nm (0.8 m · kg, 5.8 ft · lb)**

NOTE:

Tighten the pressure plate bolts in stages, using a crisscross pattern.

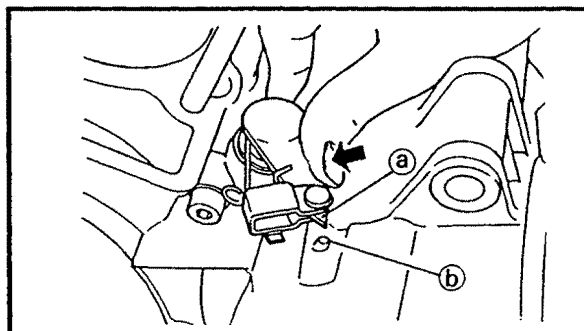

6.Check:

- Push lever position
- Push the push lever assembly in the direction of the arrow and make sure that the match marks are aligned.

Match marks not aligned. → Adjust.

- (a) Match mark on the push lever assembly
- (b) Match mark on the crankcase

7.Adjust:

- Push lever position

Adjustment steps:

- Loosen the nut (1).
- Turn the push rod #1 (2) clockwise or counterclockwise so that the match marks are aligned.
- Tighten the nut (1).

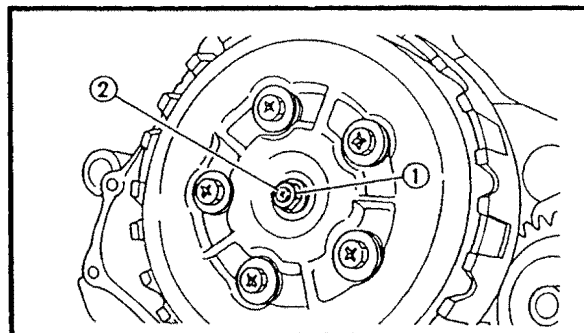

Nut (clutch adjuster):
8 Nm (0.8 m · kg, 5.8 ft · lb)



SHIFT SHAFT

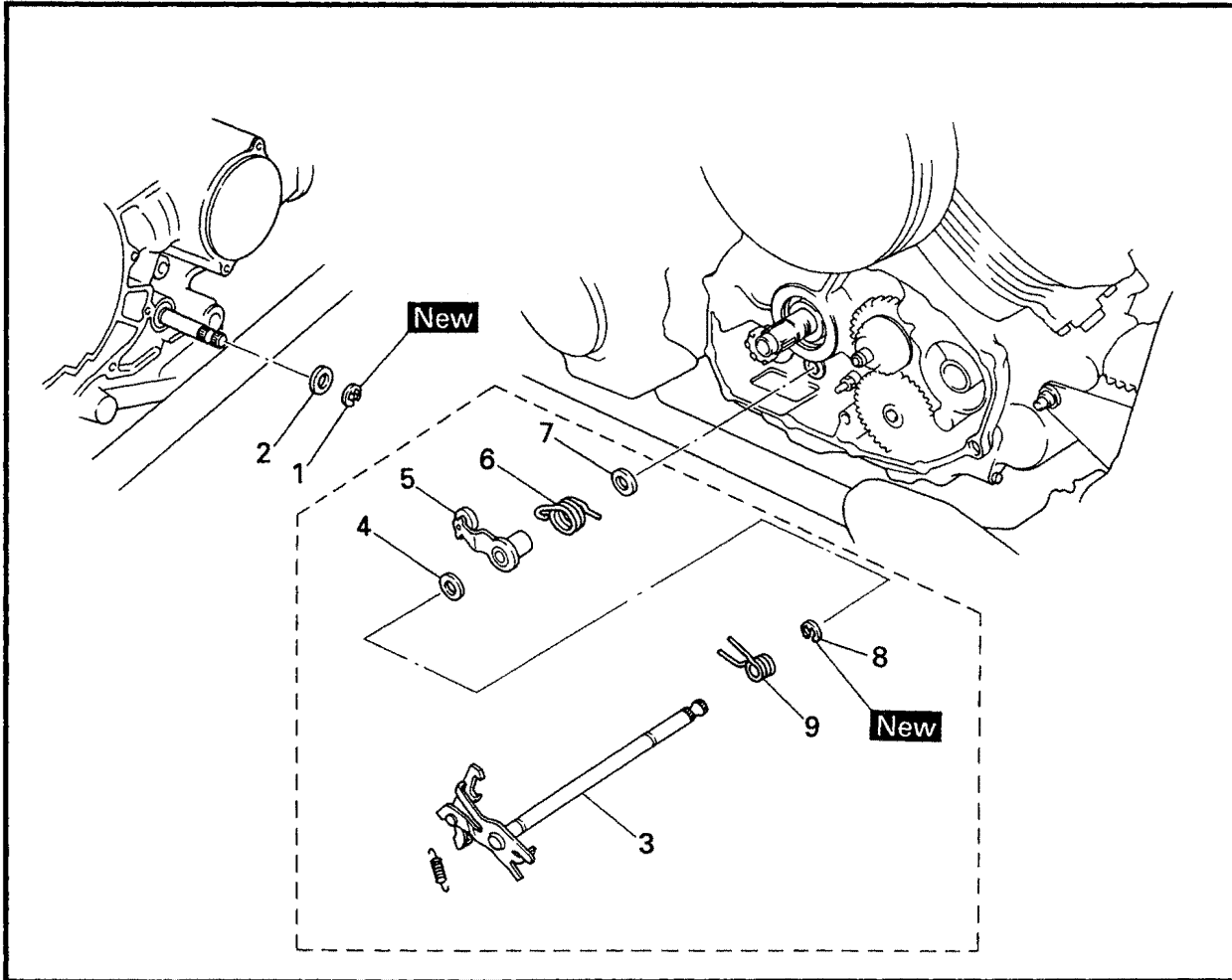

Order	Job name/Part name	Q'ty	Remarks
	Shift shaft removal		Remove the parts in the order below.
	Engine oil		Refer to "ENGINE OIL REPLACEMENT" in CHAPTER 3.
	Clutch assembly		Refer to "CLUTCH".
	Crankcase cover (left)		Refer to "ENGINE REMOVAL".
1	Circlip	1	Refer to "SHIFT SHAFT INSTALLATION".
2	Washer	1	
3	Shift shaft	1	
4	Washer	1	
5	Stopper lever	1	
6	Torsion spring (stopper lever)	1	
7	Washer	1	
8	Circlip	1	
9	Torsion spring (shift shaft)	1	
			For installation, reverse the removal procedure.

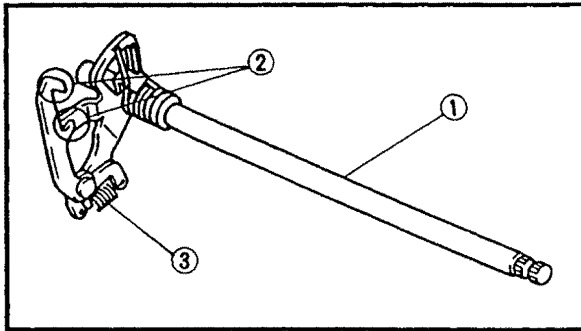

SHIFT SHAFT INSPECTION

1. Inspect:

- Shift shaft ①
 - Shift pawls ②
 - Return spring (shift arm) ③
- Bends/wear/damage → Replace.

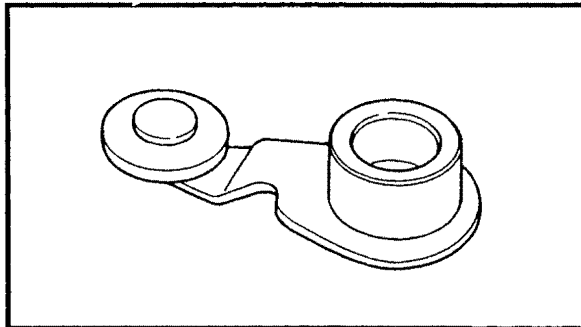

2. Inspect:

- Stopper lever
- Roller turns roughly → Replace.
Bends/damage → Replace.

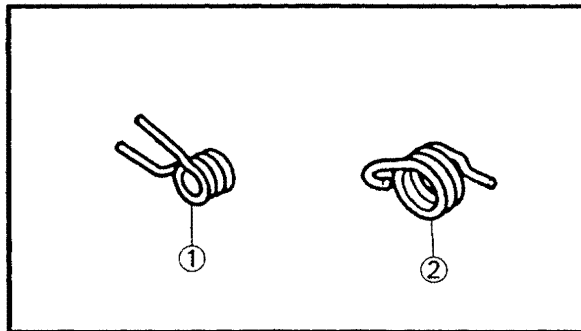

3. Inspect:

- Torsion spring (shift shaft) ①
 - Torsion spring (stopper lever) ②
- Wear/damage → Replace.

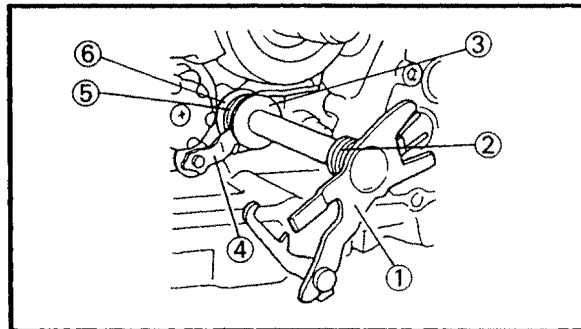

SHIFT SHAFT INSTALLATION

1. Install:

- Shift shaft ①
- Torsion spring (shift shaft) ②
- Washer ③
- Stopper lever ④
- Torsion spring (stopper lever) ⑤
- Washer ⑥

NOTE:

- Hook the spring end on the stopper lever and the crankcase boss.
- Mesh the stopper lever ⑦ with the shift cam stopper ⑧.

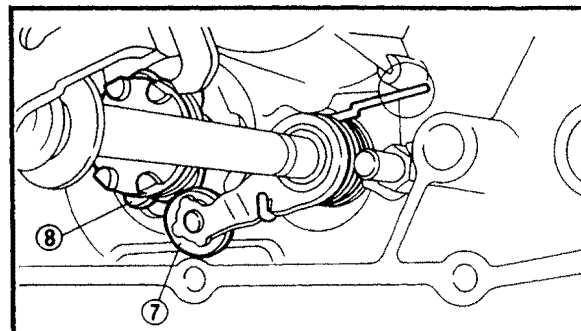

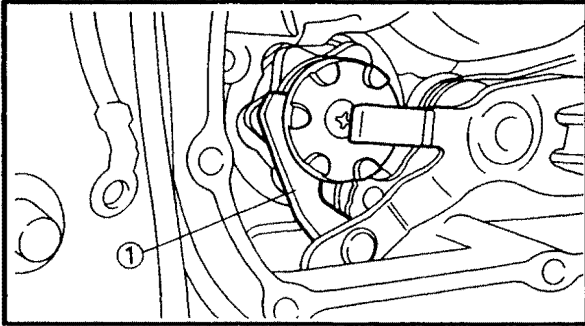

2.Install:

- Shift lever

NOTE:

Insert the shift arm ① between the pins on the shift cam segment.



OIL PUMP

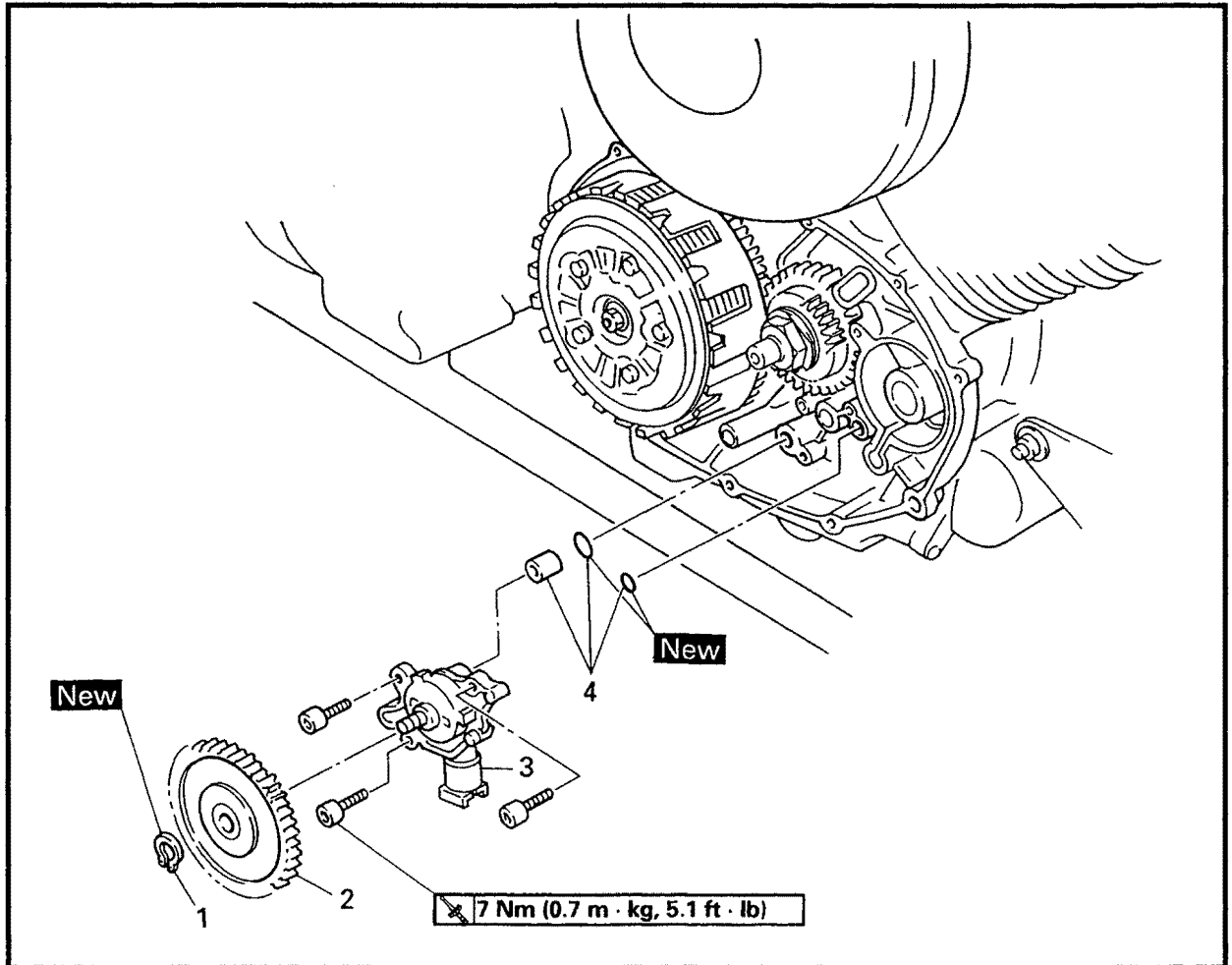

Order	Job name/Part name	Q'ty	Remarks
	Oil pump removal		Remove the parts in the order below. Refer to "CLUTCH".
	Crankcase cover (right)		
1	Circlip	1	
2	Driven gear (oil pump)	1	
3	Oil pump assembly	1	
4	O-rings/collar	2/1	For installation, reverse the removal procedure.

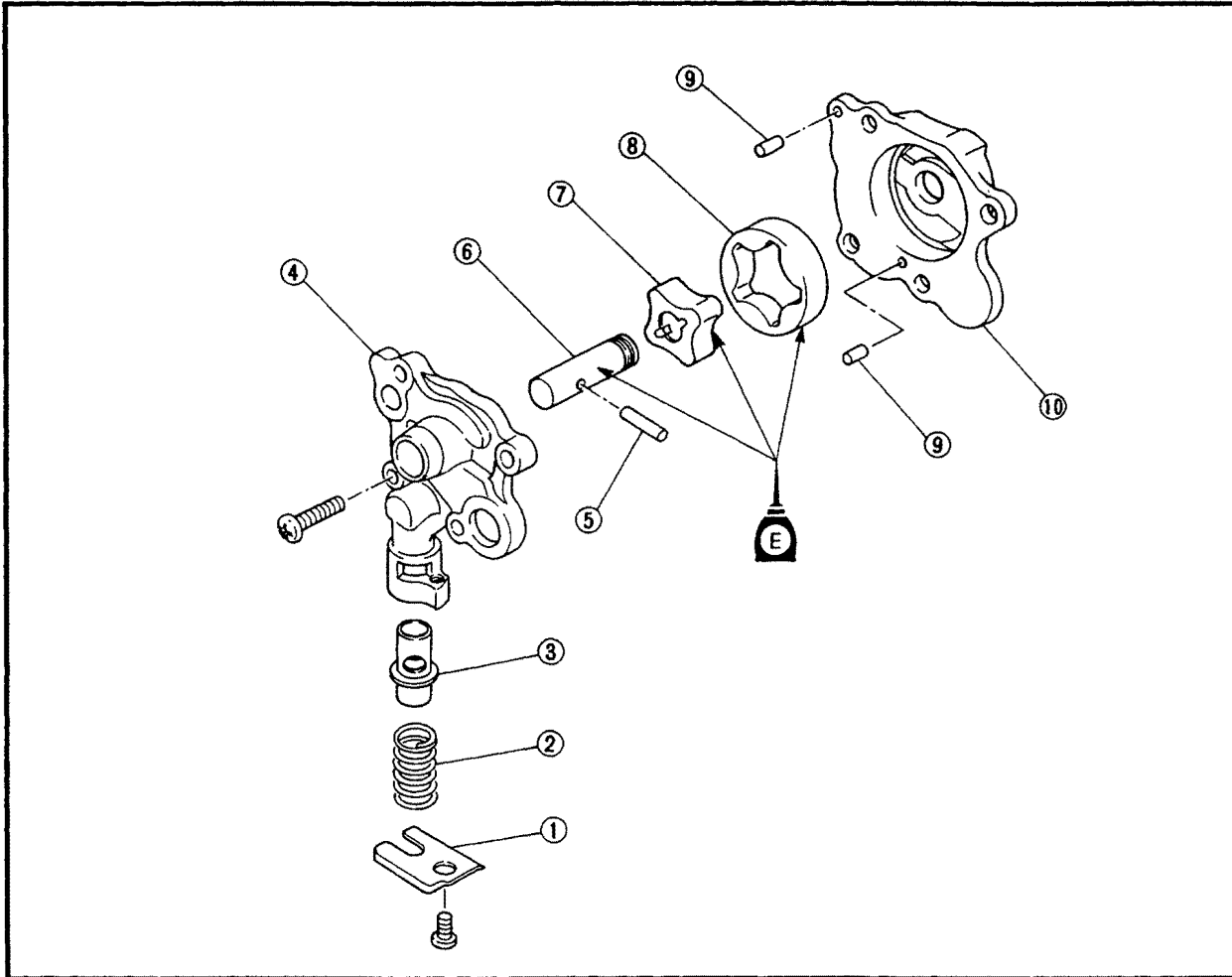

Order	Job name/Part name	Q'ty	Remarks
	Oil pump disassembly		Disassemble the parts in the order below.
①	Spring retainer	1	
②	Spring	1	
③	Relief valve	1	
④	Oil pump cover	1	
⑤	Pin	1	
⑥	Shaft	1	
⑦	Inner rotor	1	
⑧	Outer rotor	1	
⑨	Dowel pins	2	
⑩	Oil pump housing	1	
			For assembly, reverse the disassembly procedure.

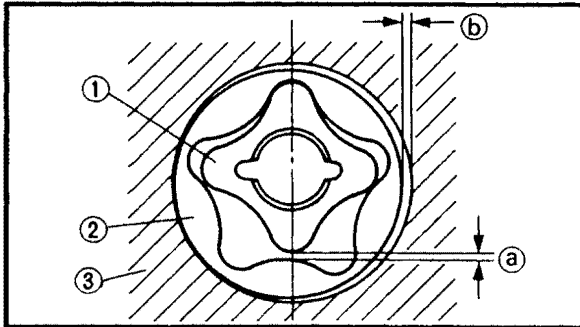
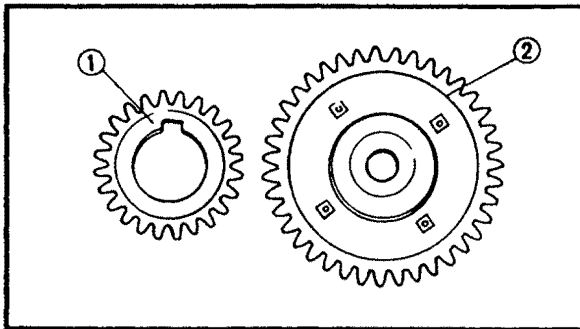
**OIL PUMP INSPECTION**

1. Inspect:

- Drive gear (oil pump) ①
 - Driven gear (oil pump) ②
- Cracks/wear/damage → Replace.

2. Measure:

- Tip clearance ③
(between the inner rotor ① and the outer rotor ②)
- Side clearance ④
(between the outer rotor ② and the pump housing ③)

Out of specification → Replace the oil pump assembly.

**Tip clearance:**

0.12 mm (0.005 in)

<Limit>: 0.2 mm (0.008 in)

Side clearance:

0.03 ~ 0.08 mm (0.001 ~ 0.003 in)

<Limit>: 0.15 mm (0.006 in)

3. Check:

- Oil pump operation
- Unsmooth operation → Replace.



AC MAGNETO AND STARTER CLUTCH
STATOR COIL AND PICKUP COIL

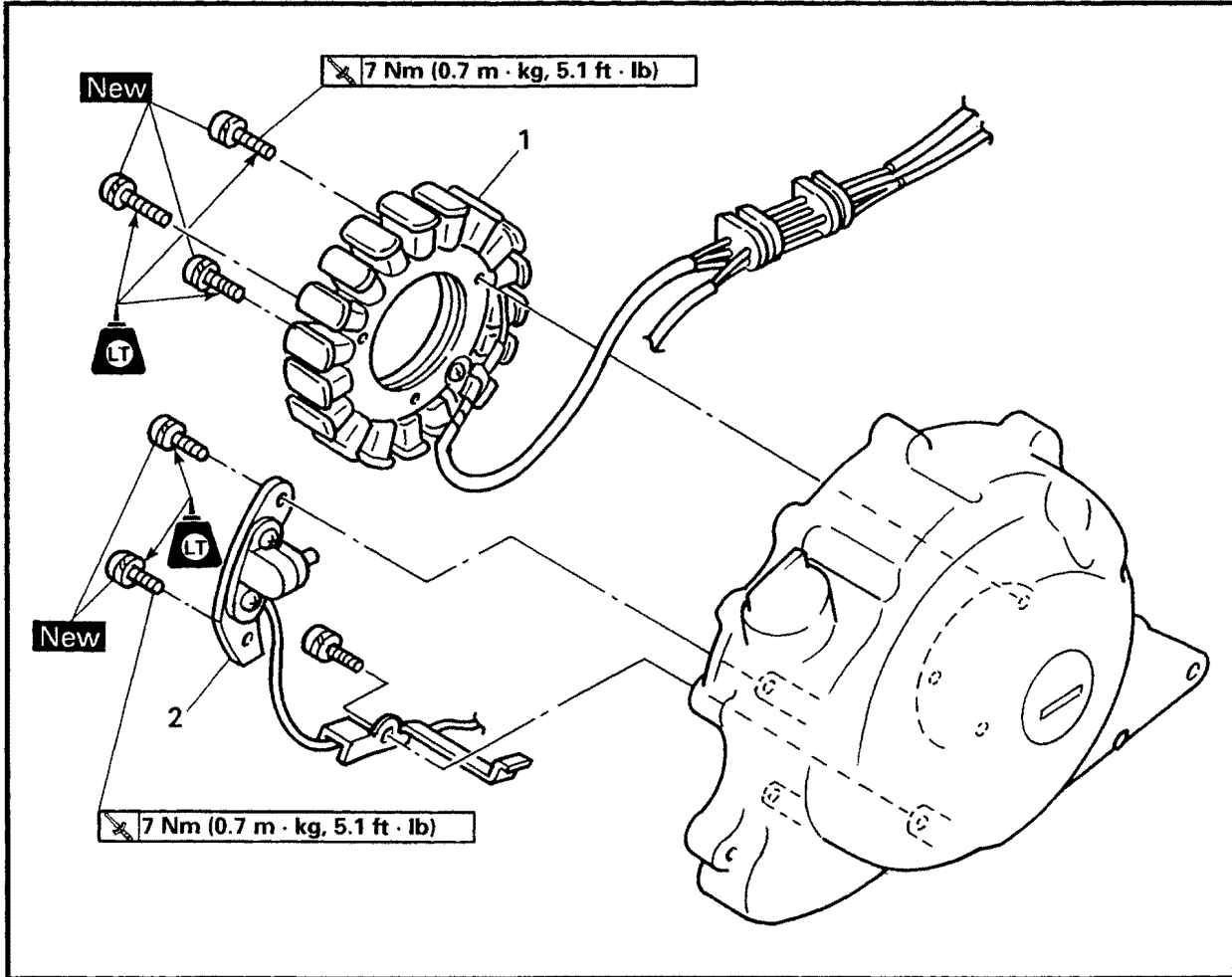

Order	Job name/Part name	Q'ty	Remarks
	Stator removal		Remove the parts in the order below.
	Engine oil		Refer to "ENGINE OIL REPLACEMENT" in CHAPTER 3.
	Crankcase cover (left)		Refer to "CLUTCH".
	Rider's seat		Refer to "FUEL TANK AND SEATS" in CHAPTER 3.
1	Stator coil	1	
2	Pickup coil	1	
			For installation, reverse the removal procedure.



AC MAGNETO AND STARTER CLUTCH

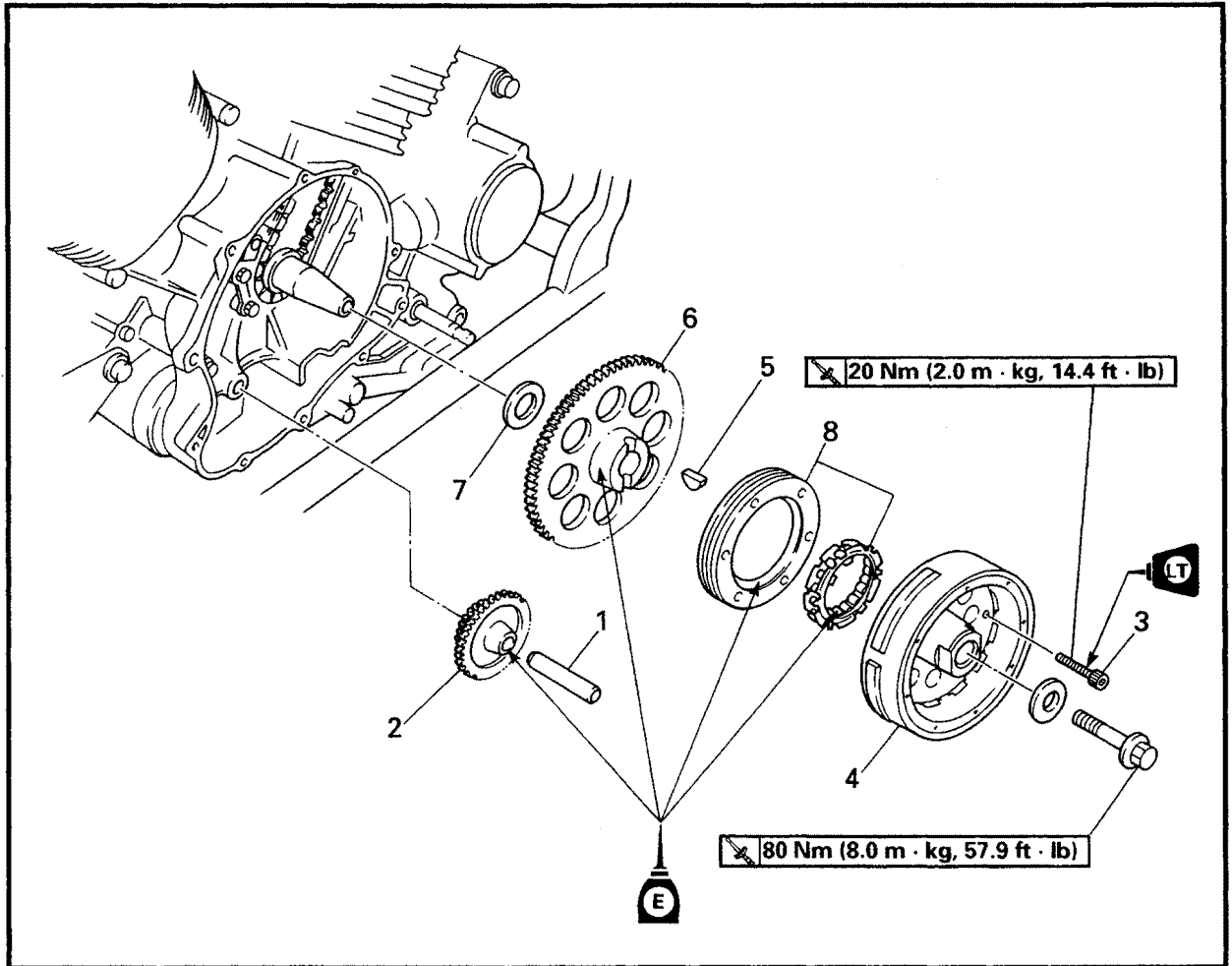

Order	Job name/Part name	Q'ty	Remarks
	AC magneto and starter clutch removal		Remove the parts in the order below.
1	Shaft	1	
2	Starter idler gear	1	
3	Bolts	3	Refer to "AC MAGNETO REMOVAL/INSTALLATION".
4	Rotor	1	
5	Woodruff key	1	
6	Starter wheel gear	1	Refer to "AC MAGNETO INSTALLATION".
7	Washer	1	
8	Starter clutch assembly	1	
			For installation, reverse the removal procedure.

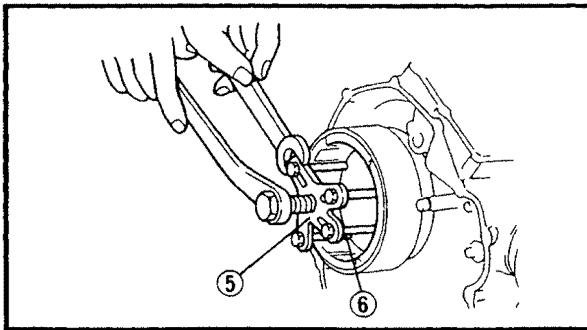
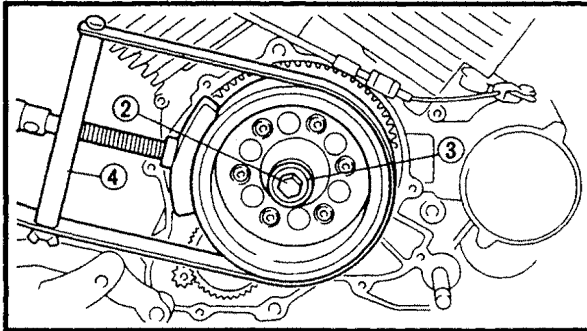
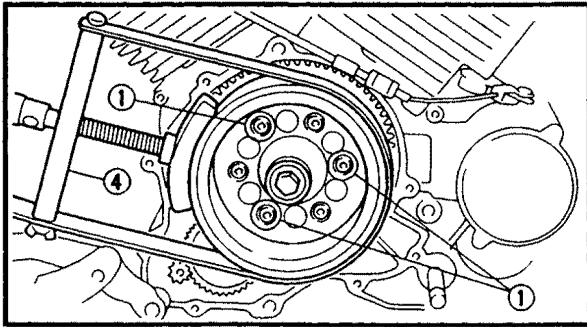

AC MAGNETO REMOVAL

1.Remove:

- Rotor
- Woodruff key

Removal steps:

- Remove the starter clutch bolts ①.
- Remove the rotor bolt ② and washer ③.

NOTE:

Loosen the starter clutch bolts ① and rotor bolt ② while holding the rotor with a sheave holder ④.



Sheave holder:

YS-01880, 90890-01701

Flywheel puller:

YU-33270, 90890-01362

Adapter:

YU-33282, 90890-04089

- Remove the rotor and the woodruff key.

NOTE:

- When installing the flywheel puller remove three of the starter clutch bolts.
- Remove the rotor by pushing back the rotor, the flywheel puller ⑤ and the adapter ⑥.
- Install the flywheel puller bolts and tighten the center bolt, making sure that the tool body stays parallel to the rotor. If necessary, one holding bolt may be backed out slightly for realignment of the tool.

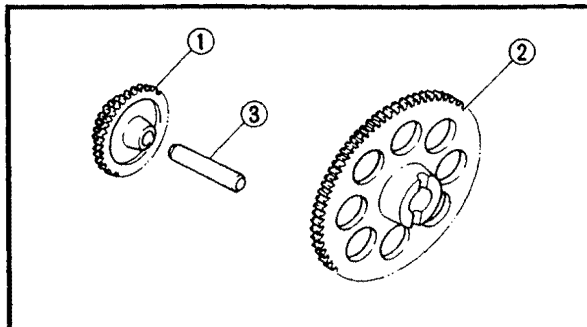

STARTER CLUTCH INSPECTION

1.Inspect:

- Gear teeth (idler) ①
- Gear teeth (starter wheel) ②
Burr/chips/roughness/wear → Replace.
- Shaft ③
Bends/damage → Replace.

2. Inspect:

- Oil passage (rotor bolt)
Clogged → Blow out with compressed air.

3. Inspect:

- Stator coil
Damage → Replace.

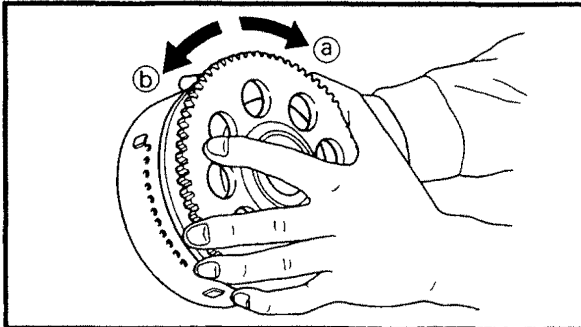

4. Check:

- Starter clutch assembly operation

Clutch operation checking steps:

- Install the starter wheel gear to the starter clutch, and hold the starter clutch.
- When turning the starter wheel gear clockwise (a), the starter clutch and the starter wheel gear should be engaged. If not, the starter clutch is faulty. Replace it.
- When turning the starter wheel gear counterclockwise (b), the starter wheel gear should turn freely. If not, the starter clutch is faulty. Replace it.

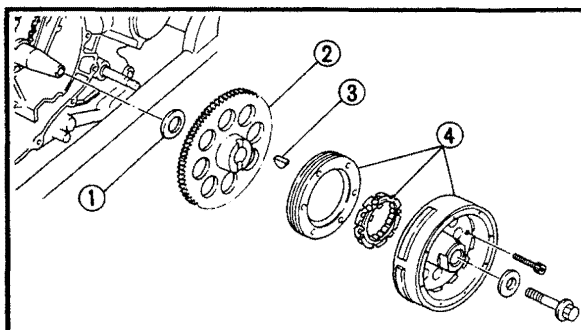

AC MAGNETO INSTALLATION

1. Install:

- Washer ①
- Starter wheel gear ②
- Woodruff key ③
- Rotor ④

NOTE:

- Clean the tapered portion of the crankshaft and the rotor hub.
- When installing the magneto rotor, make sure the woodruff key is properly seated in the key way of the crankshaft.

AC MAGNETO AND STARTER CLUTCH

ENG

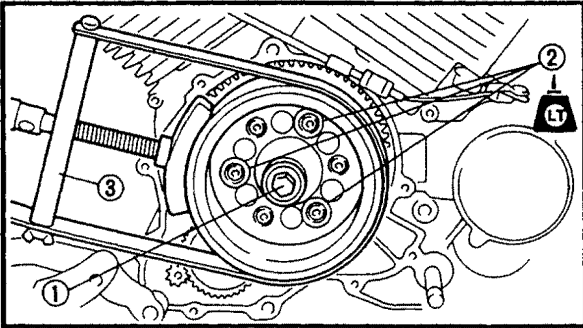

2.Tighten:

- Bolt (rotor) ①

✖ 80 Nm (8.0 m · kg, 57.9 ft · lb)

- Bolts (starter clutch) ②

✖ 20 Nm (2.0 m · kg, 14.4 ft · lb)

NOTE:

Tighten the rotor bolt ① and starter clutch bolts ② while holding the magneto rotor with a sheave holder ③.



Sheave holder:
YS-01880, 90890-01701



CRANKSHAFT AND CONNECTING RODS

CRANKCASE

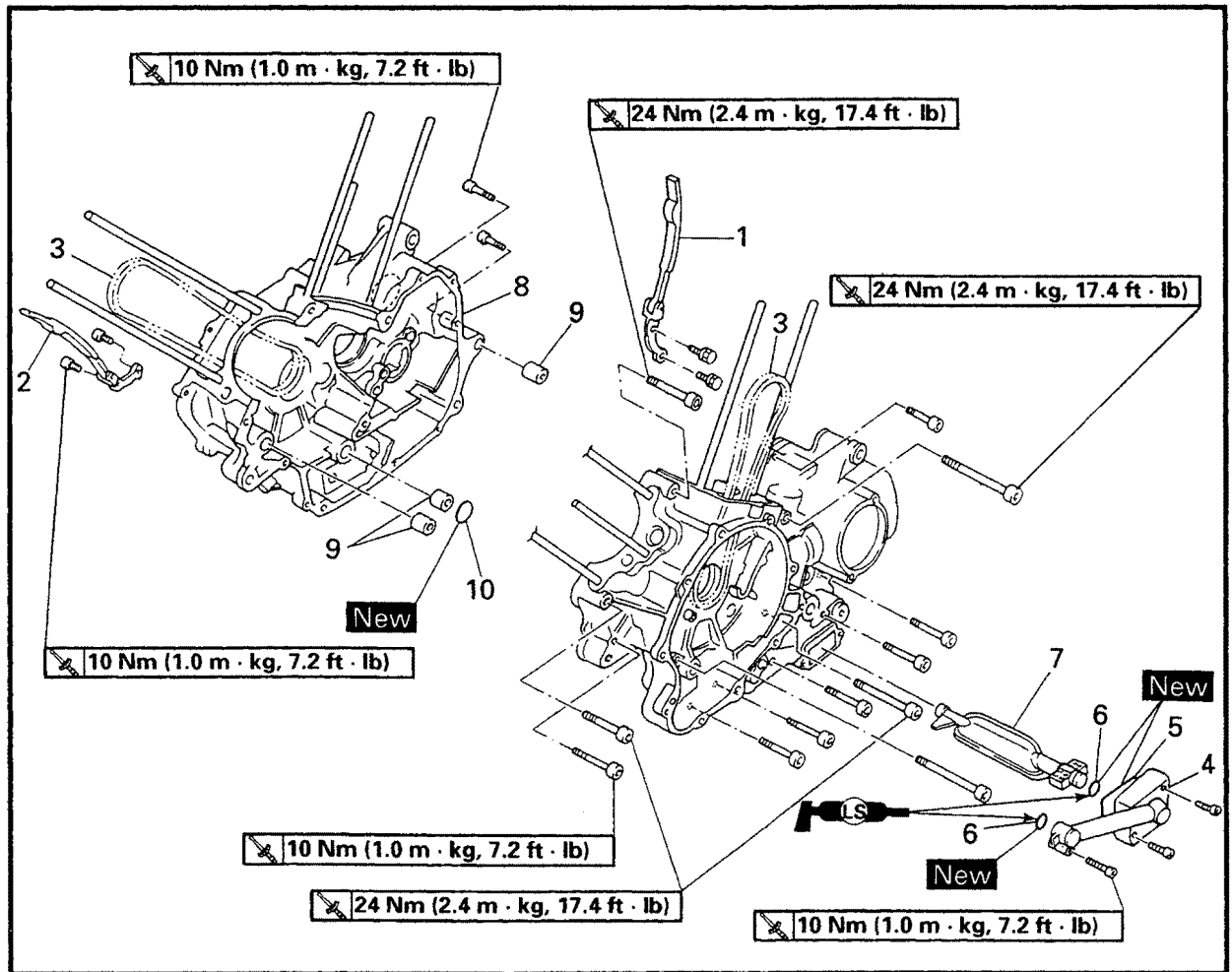

Order	Job name/Part name	Q'ty	Remarks
	Crankcase separation		Remove the parts in the order below.
	Engine assembly		Refer to "ENGINE REMOVAL".
	Cylinder head		Refer to "CYLINDER HEADS".
	Cylinder and piston		Refer to "CYLINDERS AND PISTONS".
	Clutch assembly		Refer to "CLUTCH".
	Shift shaft		Refer to "SHIFT SHAFT".
	Oil pump assembly		Refer to "OIL PUMP".
	AC magneto and starter clutch		Refer to "AC MAGNETO AND STARTER CLUTCH".
	Middle drive pinion gear		Refer to "MIDDLE GEAR".
1	Timing chain guide (rear-intake)	1	
2	Timing chain guide (front-exhaust)	1	
3	Timing chains	2	
4	Oil strainer cover	1	
5	Oil seal	1	

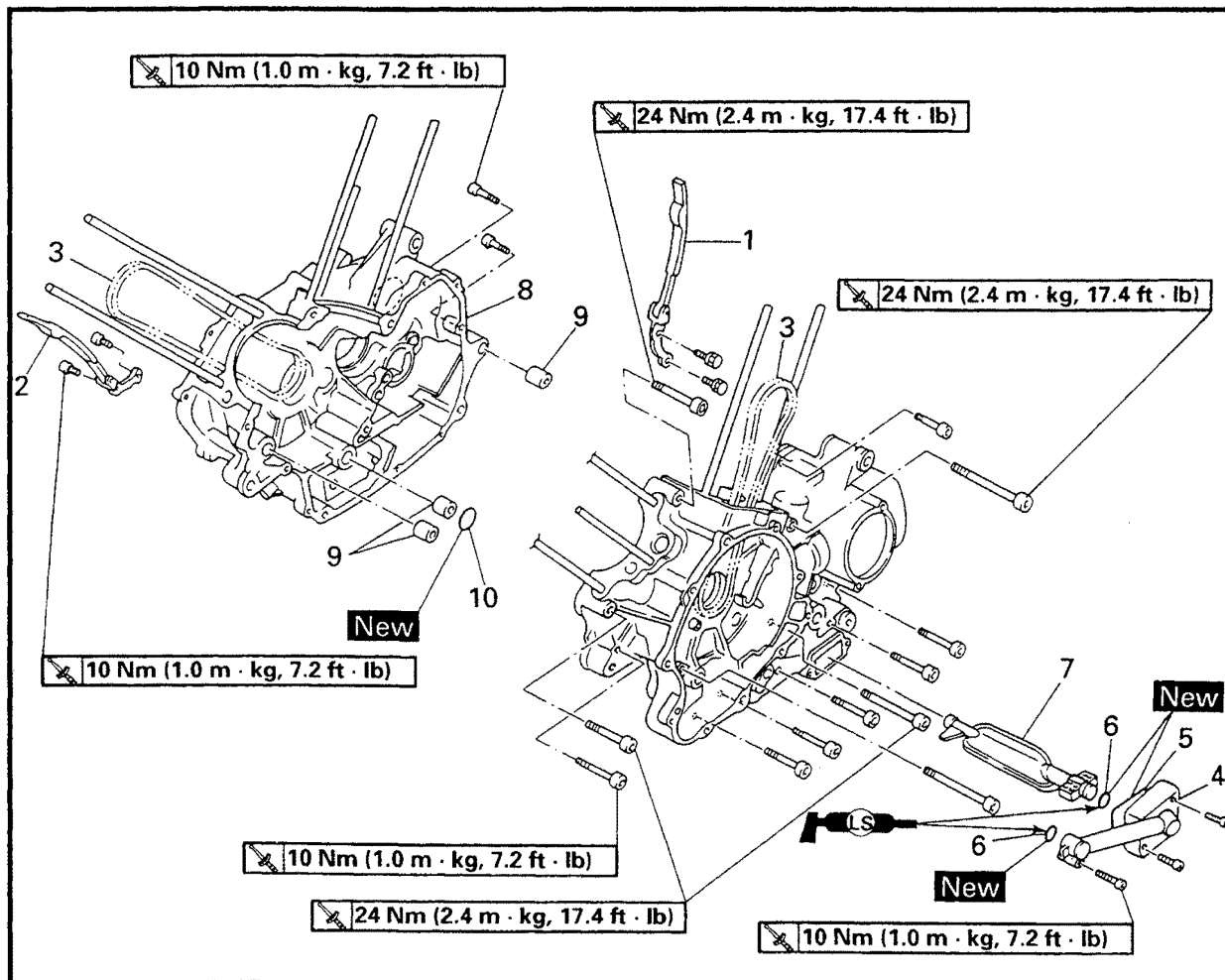

Order	Job name/Part name	Q'ty	Remarks
6	O-rings	2	
7	Oil strainer	1	
8	Crankcase (right)	1	Refer to "CRANKCASE SEPARATION/ASSEMBLY".
9	Dowel pins	3	
10	O-ring	1	
			For assembly, reverse the separation procedure.



CRANKSHAFT AND CONNECTING RODS

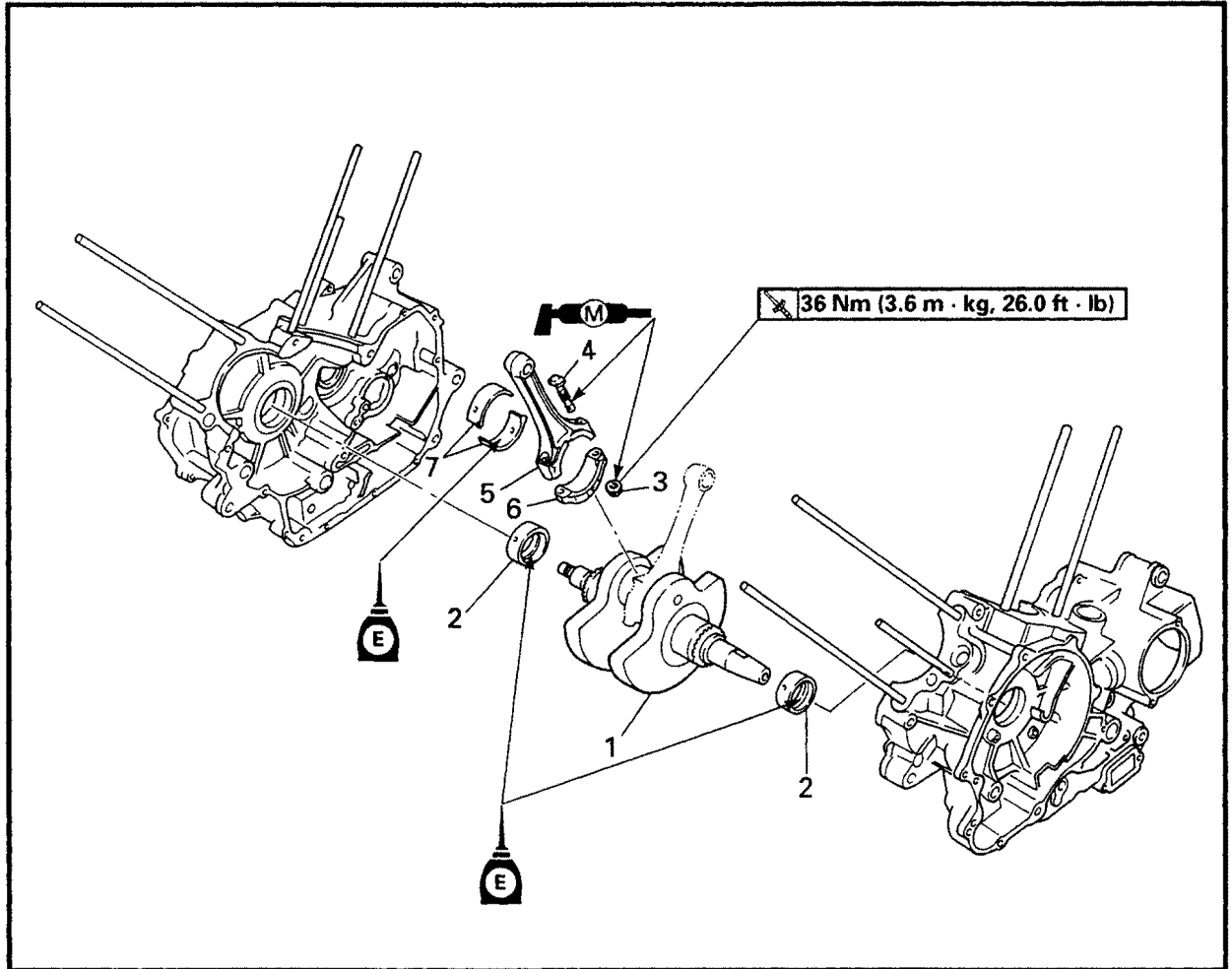

Order	Job name/Part name	Q'ty	Remarks
	Crankshaft and connecting rod removal		Remove the parts in the order below.
1	Crankshaft assembly	1	Refer to "CRANKSHAFT REMOVAL/INSTALLATION".
2	Main journal bearings	2	
3	Nuts (connecting rod caps)	4	
4	Connecting rod bolts	4	
5	Connecting rods	2	
6	Connecting rod caps	2	
7	Plain bearings	4	
			For installation, reverse the removal procedure.

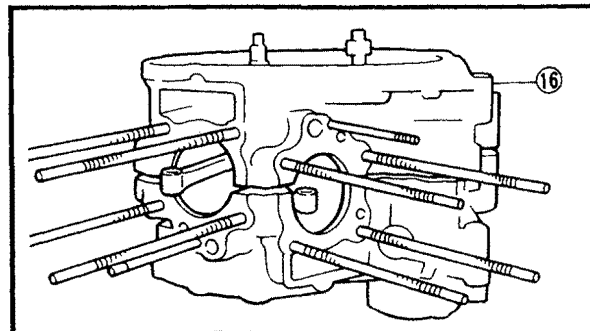
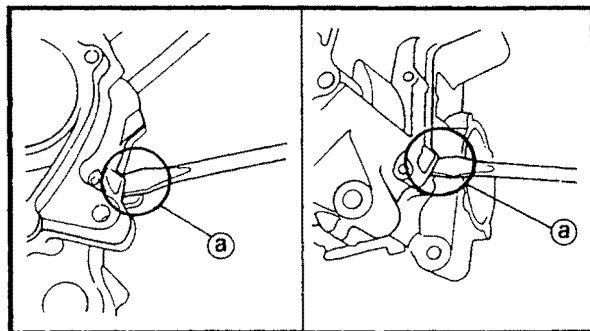
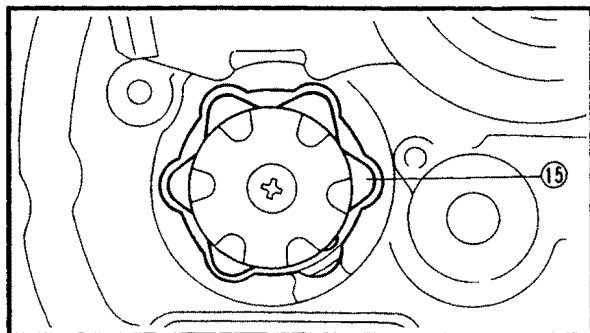
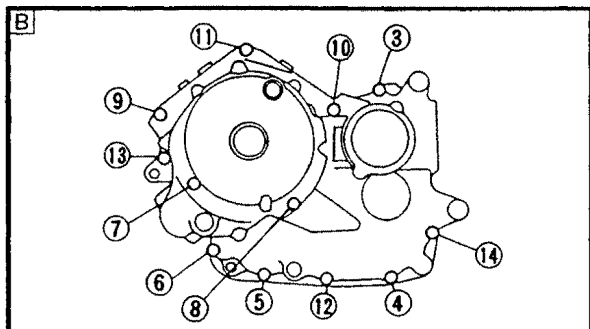
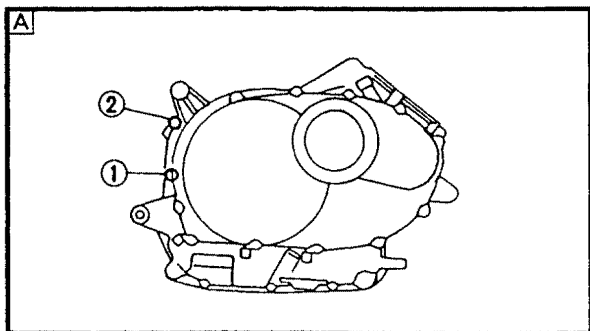

CRANKCASE SEPARATION

1. Separate:

- Left crankcase
- Right crankcase

Separation steps:

- Remove the crankcase bolts.

NOTE:

- Loosen each bolt 1/4 of a turn at a time and after all the bolts are loosened, remove them.
- Loosen the bolts in numerical order (see numbers on the illustration).
- Turn the shift cam (15) to the position shown in the figure so that it does not contact the crankcase when separating the crankcase.

A Right crankcase

B Left crankcase

- Remove the right crankcase (16).

NOTE:

For this removal, slits (a) in the crankcase can be use as shown.

CAUTION:

Use a soft hammer to tap on one side of the crankcase. Tap only on reinforced portions of the crankcase. Do not tap on the crankcase mating surfaces. Work slowly and carefully. Make sure that the crankcase halves separate evenly.

- Remove the dowel pins and O-ring.

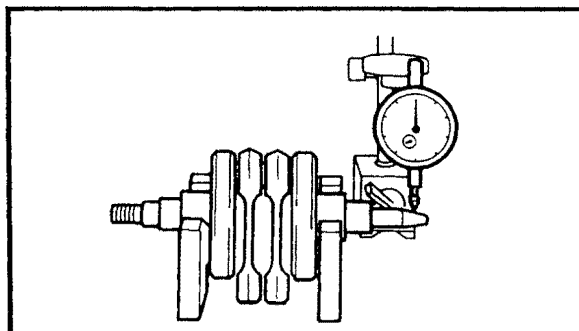
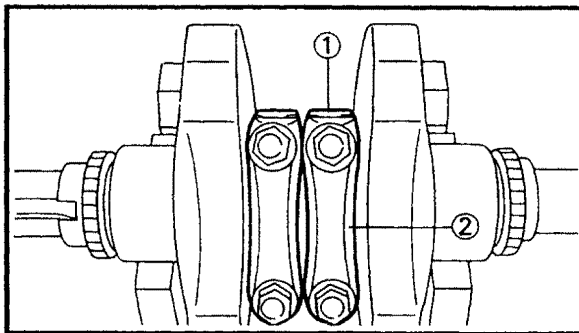
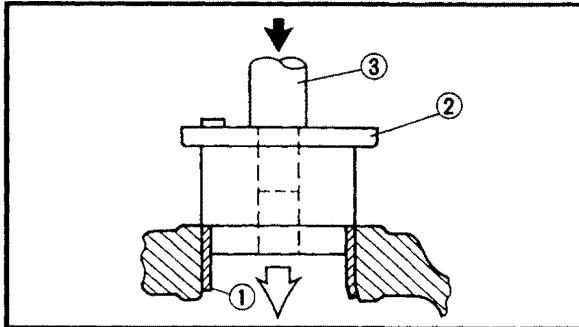
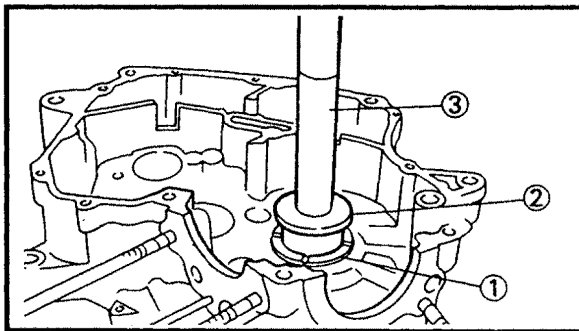

CRANKSHAFT REMOVAL

1.Remove:

- Main journal bearings ①

NOTE:

Remove the main journal bearings by the plane bearing installer/remover ② middle driven shaft bearing driver ③.



Plane bearing installer/remover:

YM-28898, 90890-04074

Middle driven shaft bearing driver:

YM-04058, 90890-04058

2.Remove:

- Connecting rod caps ①
- Connecting rod ②
- Plain bearings

NOTE:

Identify the position of each bearing very carefully so that it can be reinstalled in its original place.

CRANKSHAFT INSPECTION

- 1.Thoroughly wash the crankcase halves in mild solvent.
- 2.Thoroughly clean all the gasket mating surfaces and crankcase mating surfaces.
- 3.Inspect:
 - Crankcase
Cracks/damage → Replace.
 - Oil delivery passages
Blockage → Blow out the passages with compressed air.
- 4.Measure:
 - Runout (crankshaft)
Out of specification → Replace.



Runout limit:

0.02 mm (0.0008 in)

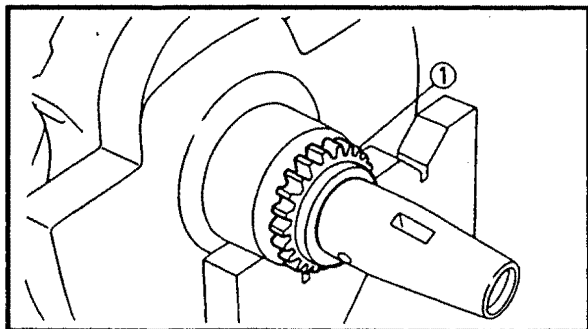

5. Inspect:
- Crank pin surfaces
 - Bearing surfaces
- Wear/scratches → Replace.
6. Inspect:
- Timing chain sprockets ①
- Damage/wear → Replace the crankshaft.

7. Measure:
- Oil clearance (crank pin)
- Out of specification → Replace the bearing.

	<p>Oil clearance (crank pin): 0.026 ~ 0.050 mm (0.001 ~ 0.002 in)</p>
---	---

Measurement steps:

CAUTION:

Do not interchange the bearings and connecting rods. To obtain the correct oil clearance and to prevent engine damage they must be installed in their original positions.

- Clean the bearings, crank pins and bearing portions of the connecting rods.
- Install the upper half of the bearing into the connecting rod and the lower half of the bearing into the connecting rod cap.

NOTE: Align the projection (a) of the bearing with the notch (b) of the connecting rod and its cap.

- Put a piece of Plastigauge® ① on the crank pin.
- Assemble the connecting rod halves.

NOTE: Do not move the connecting rod or crankshaft until the oil clearance measurement has been completed.

- Apply molybdenum disulfide grease to the bolts, threads and nut seats.

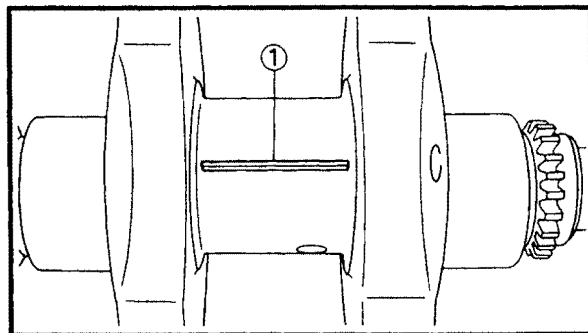
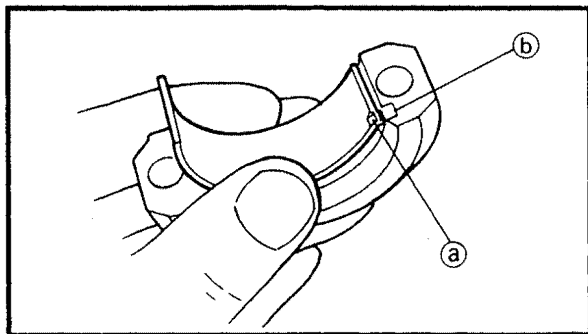

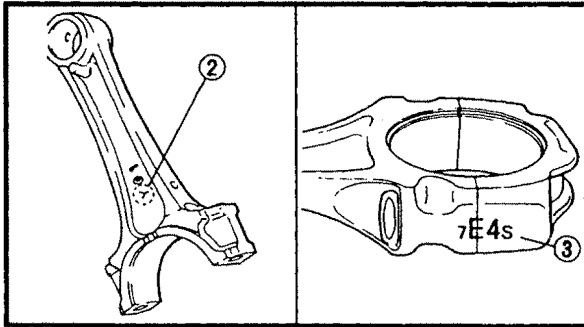

- The stamped "Y" mark ② on the connecting rods should face towards the left side of the crankcase.
- Be sure that the characters ③ on the side of the cap and connecting rod are aligned.

• Tighten the nuts.



Nuts (connecting rod caps):
36 Nm (3.6 m · kg, 26.0 ft · lb)

CAUTION:

- When tightening the nuts be sure to use an F-type torque wrench.
- Without pausing tighten to full torque specifications. Apply continuous torque between 3.0 and 3.6 m · kg. Once you reach 3.0 m · kg DO NOT STOP TIGHTENING until final torque is reached. If the tightening is interrupted between 3.0 and 3.6 m · kg, loosen the nut to less than 3.0 m · kg and start again.

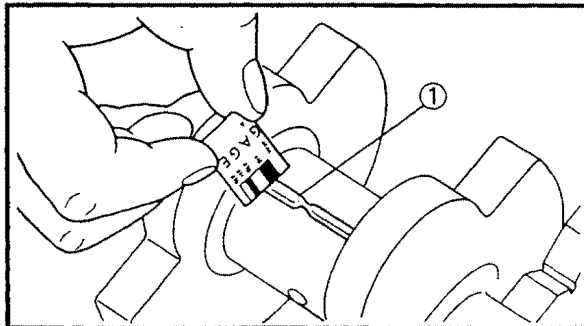

- Remove the connecting rods and bearings.
- On each crank pin measure the width of the compressed Plastigauge® ①. If the oil clearance is out of specification, select a replacement bearing.

8. Select:

- Crank pin bearing (P₁)

NOTE:

- The numbers ① indicate crankshaft journal sizes are stamped on the crankweb, as shown in the illustration.
- The numbers ② are stamped in ink on the connecting rod and connecting rod cap, as shown in the illustration.

Selection of crank pin bearings:

- If "P₁" on the connecting rod is "4" and "P₁" on the crankweb is "2", then the bearing size for "P₁" is:

Bearing size of P₁:
Connecting rod P₁ – Crankweb P₁ =
4 – 2 = 2 (black)

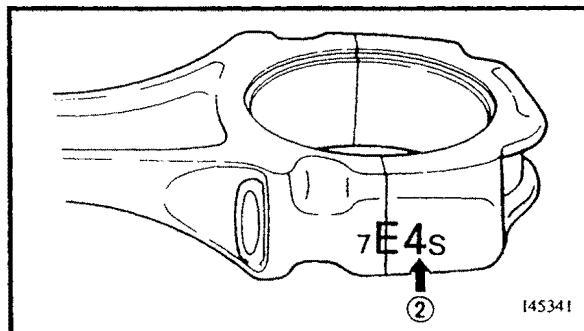
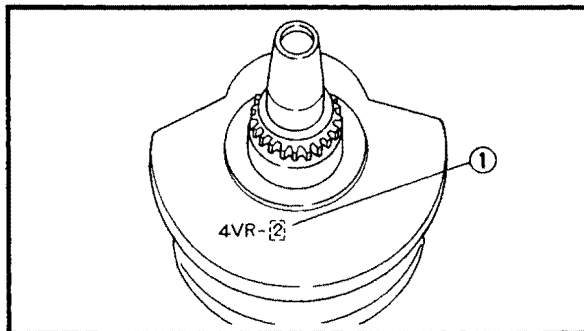

BEARING COLOR CODE	
1	blue
2	black
3	brown
4	green

9.Measure:

- Oil clearance (main journal)
Out of specification → Replace the bearing.



Oil clearance (main journal):
0.020 ~ 0.052 mm
(0.0008 ~ 0.002 in)

Measurement steps:

CAUTION: _____

On the journal, the larger value is used as a basis for calculation of the oil clearance, and on the journal bearing, the smaller value is used.

- Clean the surface of main journal and journal bearings.
- Check the bearing surface. If the bearing surface is worn or scratched, the bearings should be replace.

NOTE: _____

If either of the right or left journal bearing is worn or scratched, both bearings should be replaced as a set.

- Measure the outside diameter ① of each main journal at two places. If it is out of specification, replace the crankshaft.



Outside diameter limit (main journal):
44.95 mm (1.77 in)

- Measure the inside diameter ② of each journal bearing at two places.

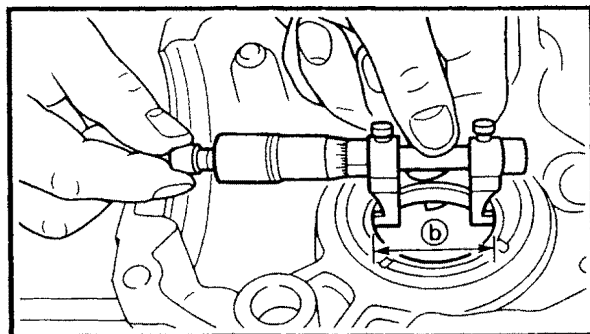
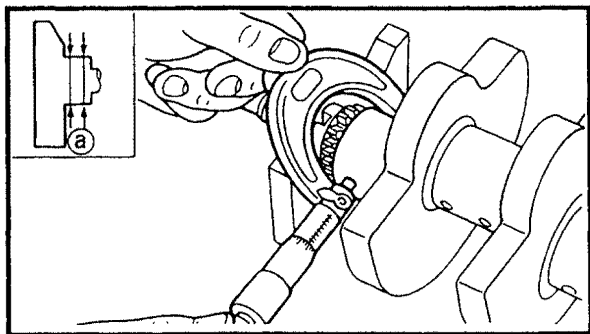

- If journal bearing inside diameter is “45.03 (1.7728 in)” and crankshaft journal outside diameter is “44.98 (1.7709 in)” then the main journal oil clearance is:

Main journal oil clearance:
Journal bearing inside diameter –
Main journal outside diameter =
45.03 – 44.98 = 0.05 mm
(1.7728 – 1.7709 = 0.0019 in)

If the oil clearance is out of specification, select a replacement bearings.

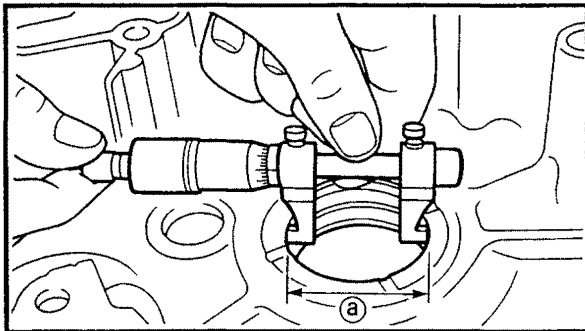

10. Select:

- Main journal bearing

Selection of main journal bearings:

- Remove the main journal bearings out of crankcase.
- Clean the bearing seat in the crankcase where the bearing is fitted.
- Measure the diameter ⓐ of the bearing seat at two places.

NOTE:

If the diameter of the bearing seat in the crankcase exceeds 49.02 mm, the crankcase should be replaced with a new one. The new crankcase includes new journal bearings. The each inside diameter of bearing is normally 45.000 ~ 45.012 mm.

CAUTION:

The average of the two values is used to choose the bearing.

- Select the proper oversized main journal bearing with the following table.

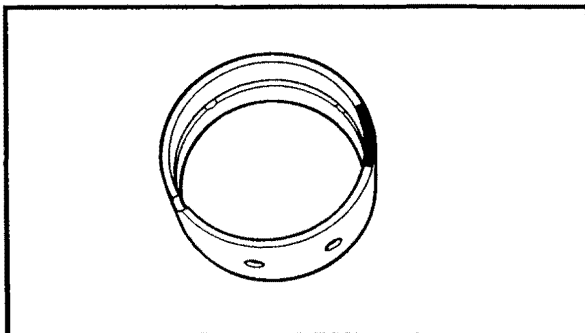

DIAMETER OF THE BEARING SEAT	COLOR CODE
49.000 ~ 49.010 mm (1.9291 ~ 1.9295 in)	blue
49.011 ~ 49.020 mm (1.9296 ~ 1.9299 in)	green

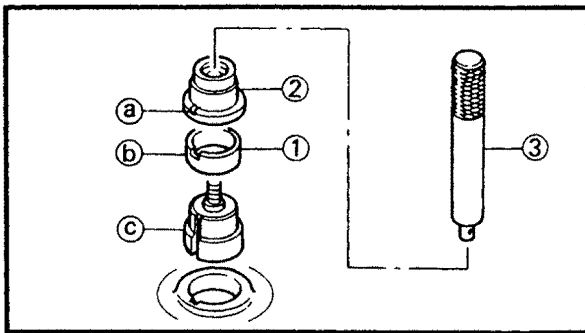

CRANKSHAFT INSTALLATION

1. Attach:

- Main journal bearings ①

NOTE:

- Attach the main journal bearing to the plane bearing installer/remover ② middle driven shaft bearing driver ③.
- Align the projection ① on the bearing with the projection ② and slot ③ on the special tools.



Plane bearing installer/remover:

YM-28898, 90890-04074

Middle driven shaft bearing driver:

YM-04058, 90890-04058

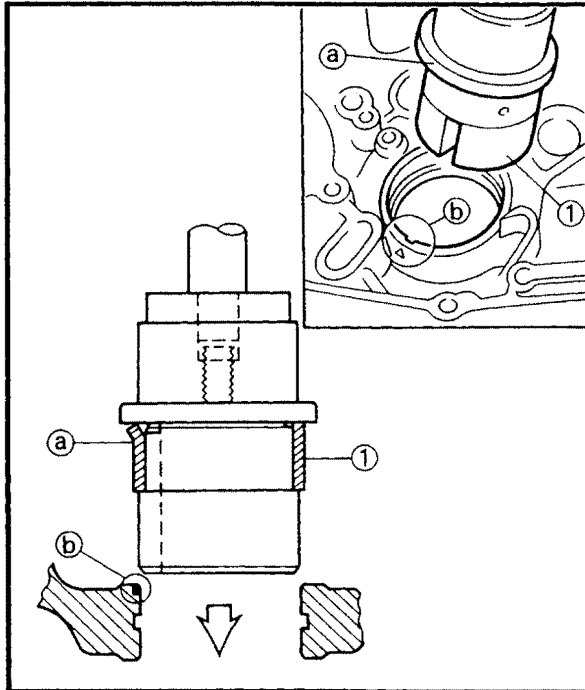

2. Install:

- Main journal bearings ①

NOTE:

Align the projection ① on the bearing with the slit ② on the crankcase.

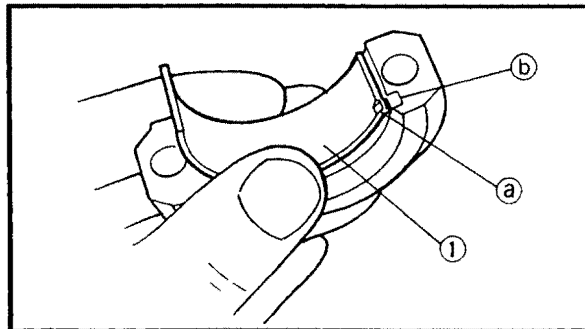

3. Install:

- Connecting rod bearings ①

NOTE:

- Align the projection ① of the bearings with the notches ② in the connecting rod cap.
- Install each bearing in its original place.

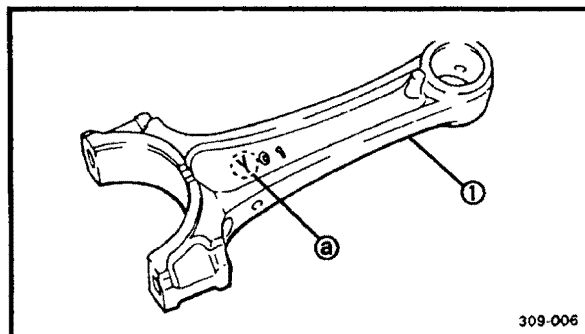

4. Install:

- Connecting rods ①

NOTE:

- The stamped "Y" mark ① on the connecting rods should face outward of the crankcase.
- Install each connecting rod in its original place.

309-006

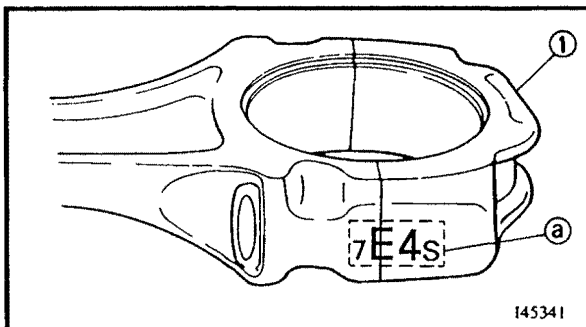

5. Install:

- Connecting rod cap ①

NOTE:

Be sure that the characters ② on the side of the cap and connecting rod are aligned.

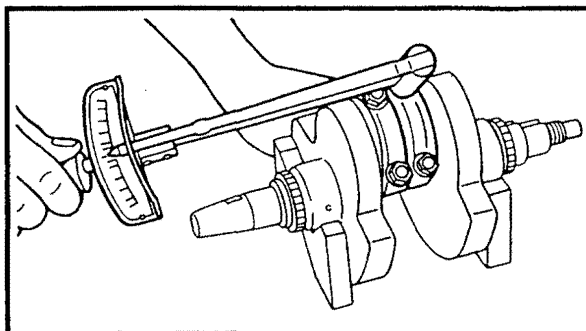

6. Tighten:

- Nuts (connecting rod cap)

36 Nm (3.6 m · kg, 26.0 ft · lb)

NOTE:

Apply molybdenum disulfide grease to the rod cap bolt threads and nut surfaces.

CAUTION:

- When tightening the nuts be sure to use an F-type torque wrench.
- Without pausing tighten to full torque specification. Apply continuous torque between 3.0 and 3.6 m · kg. Once you reach 3.0 m · kg DO NOT STOP TIGHTENING until final torque is reached. If the tightening is interrupted between 3.0 and 3.6 m · kg, loosen the nut to less than 3.0 m · kg and start again.

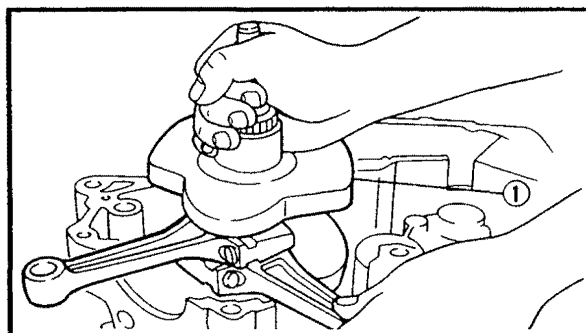

7. Install:

- Crankshaft ①

NOTE:

Align the left connecting rod with the rear cylinder sleeve hole.

CRANKCASE ASSEMBLY

1. Apply:

- Engine oil
(onto the main journal bearings)
- Sealant
(onto the crankcase mating surfaces)



**Yamaha Bond No. 1215:
ACC-1100-15-01, 90890-85505**

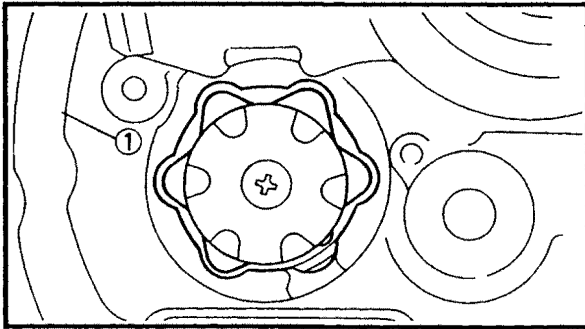

2. Install:
- Right crankcase
(onto the left crankcase)

NOTE: Turn the shift cam to the position shown in the figure so that it does not contact the crankcase when installing the crankcase.

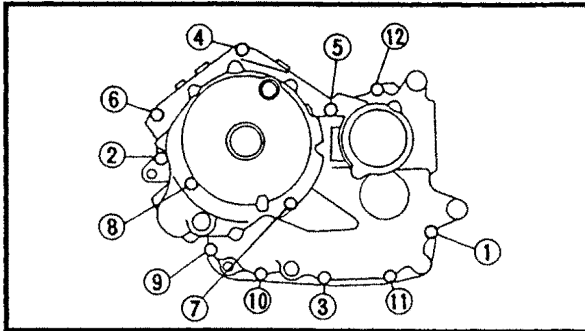

3. Tighten:
- Crankcase bolts
(follow the proper tightening sequence)

NOTE: The numbers embossed on the crankcase indicate the crankcase tightening sequence.

- ④ ~ ⑦ (M8) 24 Nm (2.4 m · kg, 17.4 ft · lb)
- ① ~ ③, ⑧ ~ ⑭ (M6) 10 Nm (1.0 m · kg, 7.2 ft · lb)

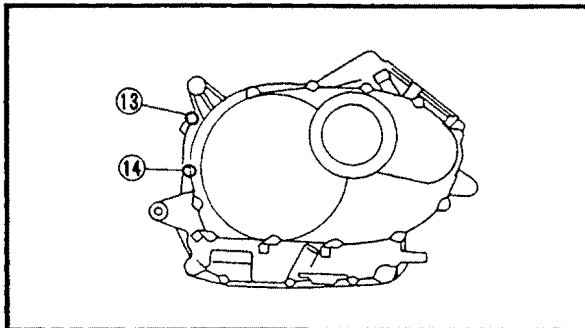

- NOTE:**
- Lubricate the bolt threads with engine oil.
 - Tighten the bolts in increasing numerical order.

M6 × 45 mm	①, ③, ⑨ ~ ⑭
M6 × 55 mm	②
M6 × 95 mm	⑧
M8 × 60 mm	④, ⑥
M8 × 80 mm	⑦
M8 × 100 mm	⑤



TRANSMISSION

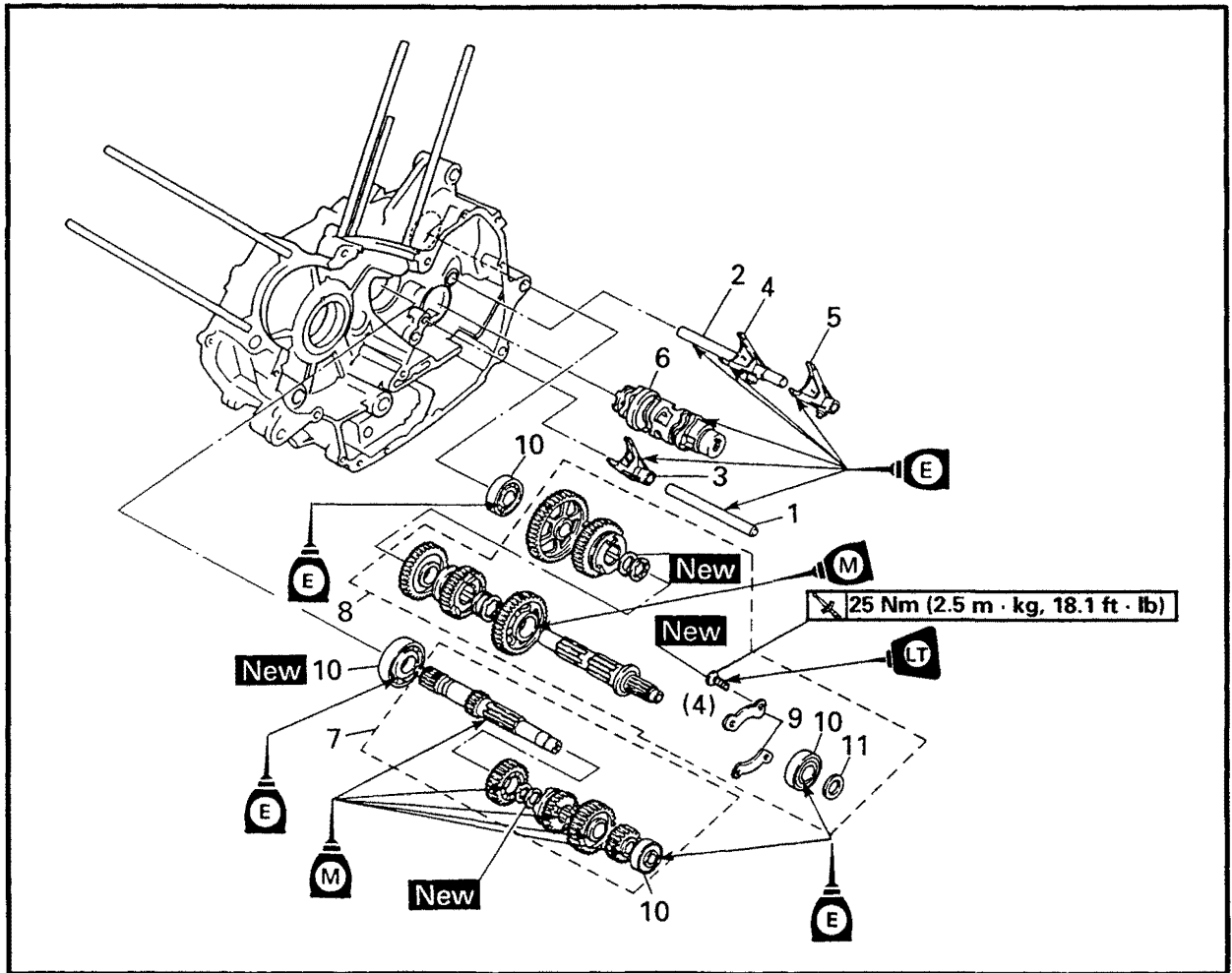

Order	Job name/Part name	Q'ty	Remarks
	Transmission removal		Remove the parts in the order below.
	Crankcase separation		Refer to "CRANKSHAFT".
1	Guide bar 1	1	Refer to "TRANSMISSION INSTALLATION".
2	Guide bar 2	1	
3	Shift fork 2 "C"	1	
4	Shift fork 3 "R"	1	
5	Shift fork 1 "L"	1	
6	Shift cam	1	
7	Main axle assembly	1	
8	Drive axle assembly	1	
9	Bearing retainer	2	
10	Bearings	4	
11	Shim	1	
			For installation, reverse the removal procedure.

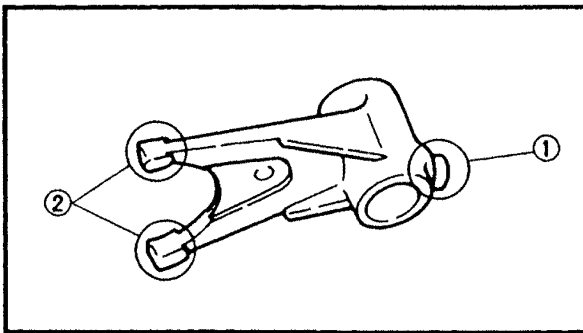

SHIFT FORK INSPECTION

1. Inspect:

- Shift fork cam follower ①
 - Shift fork pawl ②
- Scoring/bends/wear/damage → Replace.

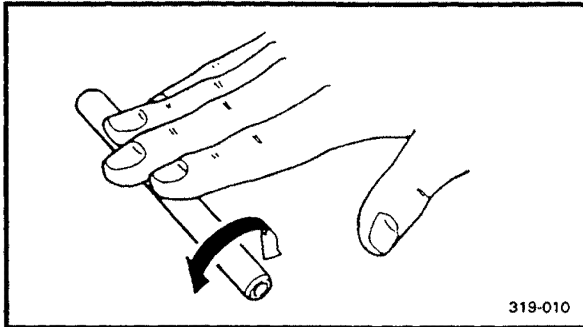

2. Inspect:

- Guide bar
- Roll the guide bar on a flat surface.
Bends → Replace.

⚠ WARNING

Do not attempt to straighten a bent guide bar.

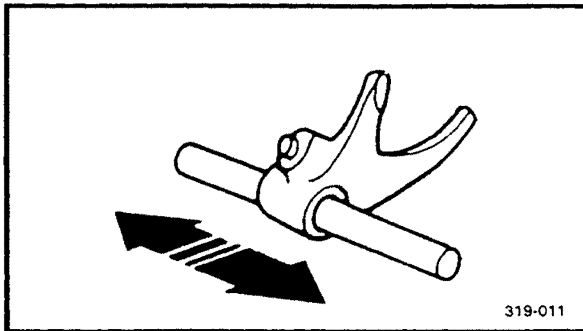

3. Check:

- Shift fork movement (on the guide bar)
- Unsmooth operation → Replace the shift fork and the guide bar.

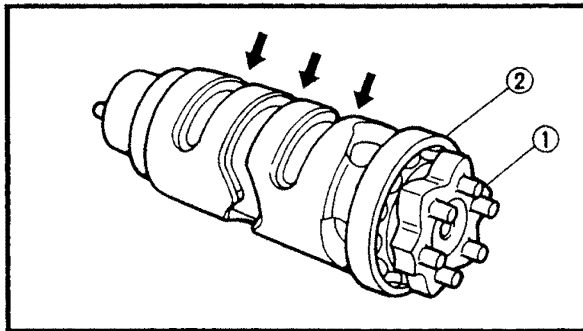

SHIFT CAM INSPECTION

1. Inspect:

- Shift cam grooves
 - Shift cam segment ①
 - Shift cam bearing ②
- Scratches/wear/damage → Replace.
Wear/damage → Replace.
Pitting/damage → Replace.

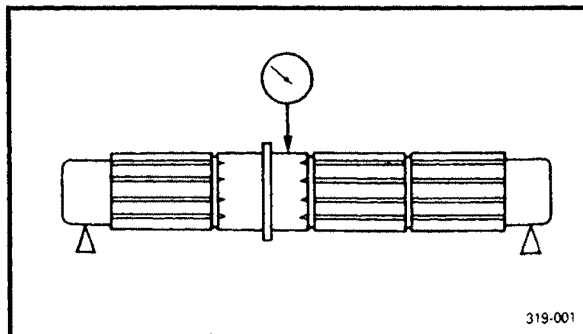

TRANSMISSION INSPECTION

1. Measure:

- Axle runout
- Use a centering device and a dial gauge.
Out of specification → Replace the bent axle.



Runout limit (main and drive axle):
0.06 mm (0.0024 in)

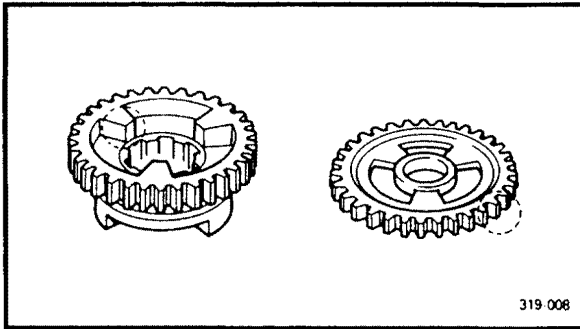

319.008

2. Inspect:

- Gear teeth
Blue discoloration/pitting/wear → Replace.
- Mated dogs
Rounded edges/cracks/missing portions → Replace.

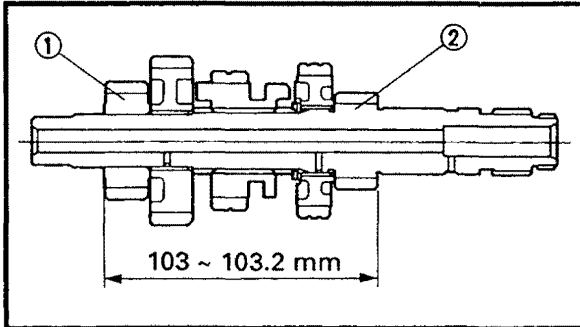

3. Check:

- Proper pinion gear engagement (each gear to its counter part)
Incorrect → Reassemble.
- Gear movement
Roughness → Replace.

Transmission gear reassembling point:

Press the 2nd pinion gear ① into the 1st pinion gear (main axle) ②.

4. Inspect:

- Circlip
Bends/looseness/damage → Replace.

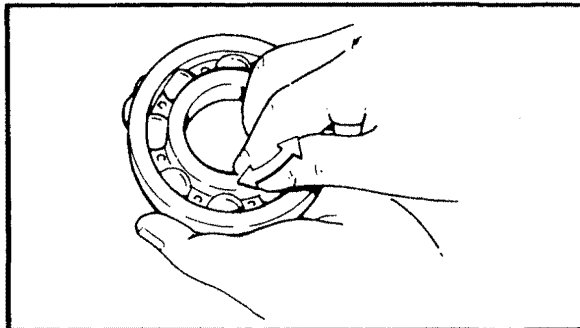

5. Inspect:

- Bearings
Unsmooth → Replace.

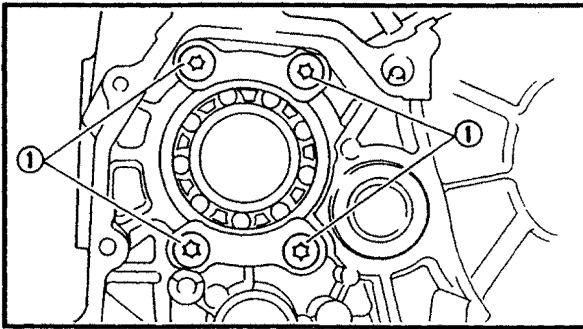
**TRANSMISSION INSTALLATION****1. Tighten:**

- Torx screws (bearing retainer) ① **New**

25 Nm (2.5 m · kg, 18.1 ft · lb)

Use #40 torx screw wrench.

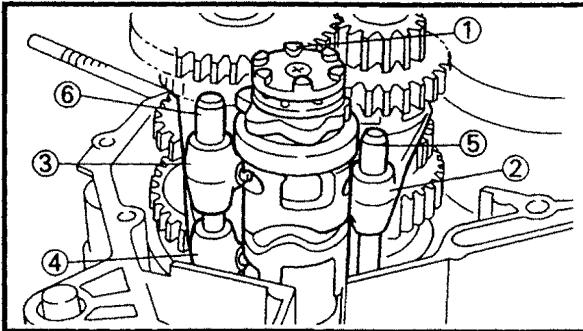
2. Lock the torx screw head with drift punch.**3. Install:**

- Shift cam ①
- Shift fork 2 "C" ②
- Shift fork 3 "R" ③
- Shift fork 1 "L" ④
- Guide bar 1 ⑤
- Guide bar 2 ⑥

NOTE:

The number stamped into the shift fork must always face towards the right side of the crankcase. Be sure that the shift fork guide pin is properly seated in the shift drum groove.

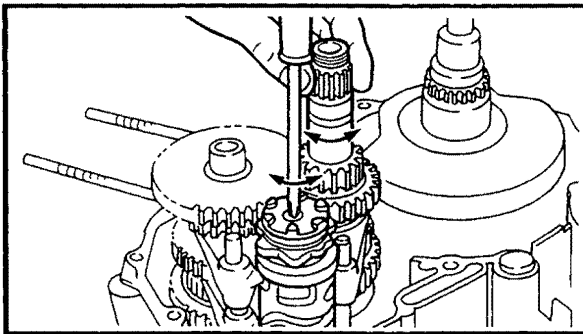
**4. Check:**

- Shift operation
Unsmooth operation → Repair.

NOTE:

- Oil each gear and bearing thoroughly.
- Before assembling the crankcase, be sure that the transmission is in neutral and that the gears turn freely.



MIDDLE GEAR
MIDDLE DRIVEN PINION GEAR

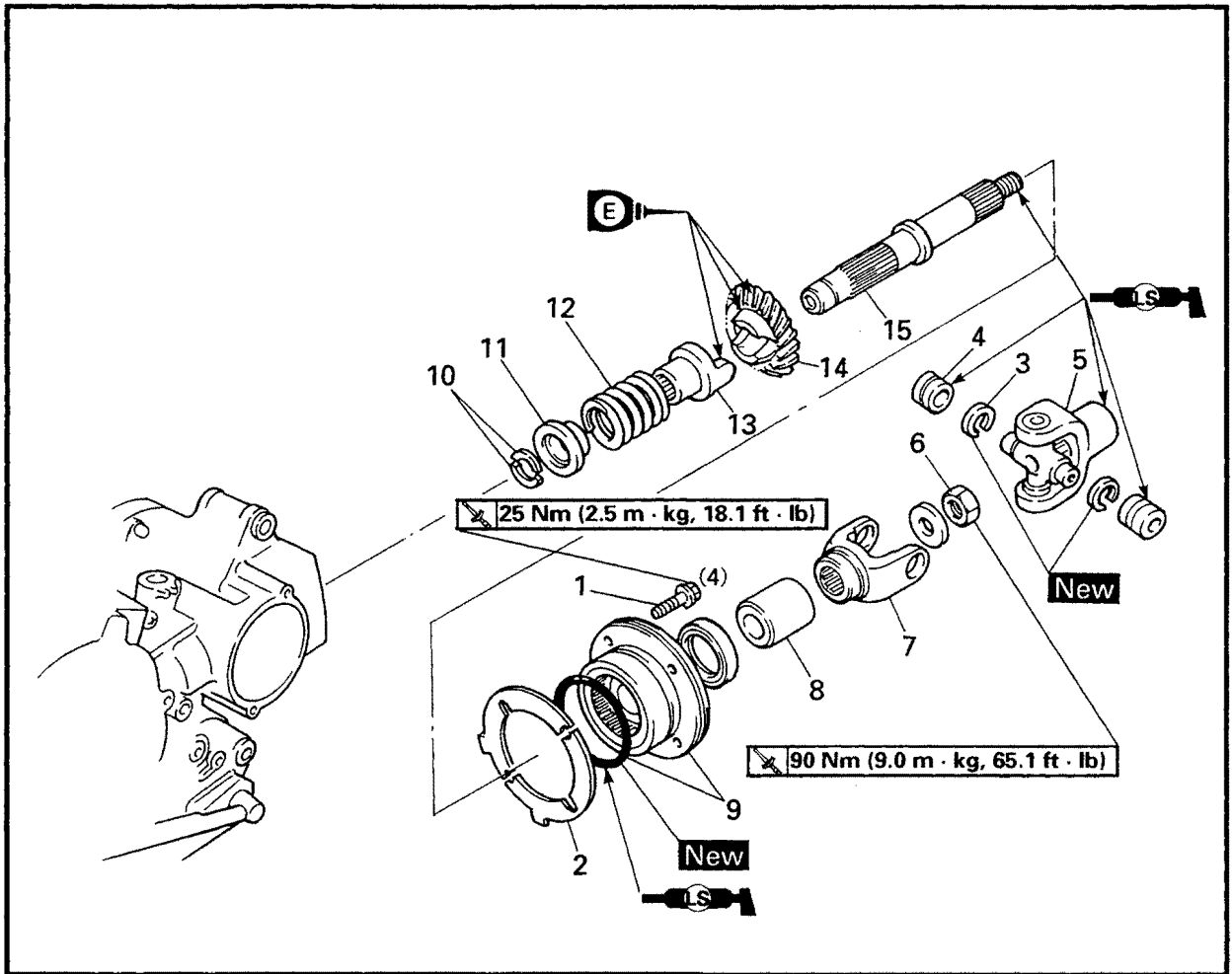

Order	Job name/Part name	Q'ty	Remarks
	Middle driven pinion gear removal		Remove the parts in the order below. Refer to "ENGINE REMOVAL". Refer to "MIDDLE DRIVEN PINION GEAR REMOVAL/INSTALLATION".
	Engine assembly		
1	Bolts	4	
2	Shim	1	
3	Circlips	4	
4	Bearings	4	
5	Yoke	1	
6	Nut	1	
7	Yoke	1	
8	Collar	1	
9	Bearing housing/O-ring	1/1	
10	Spring retainers	2	
11	Spring seat	1	
12	Damper spring	1	
13	Damper cam	1	

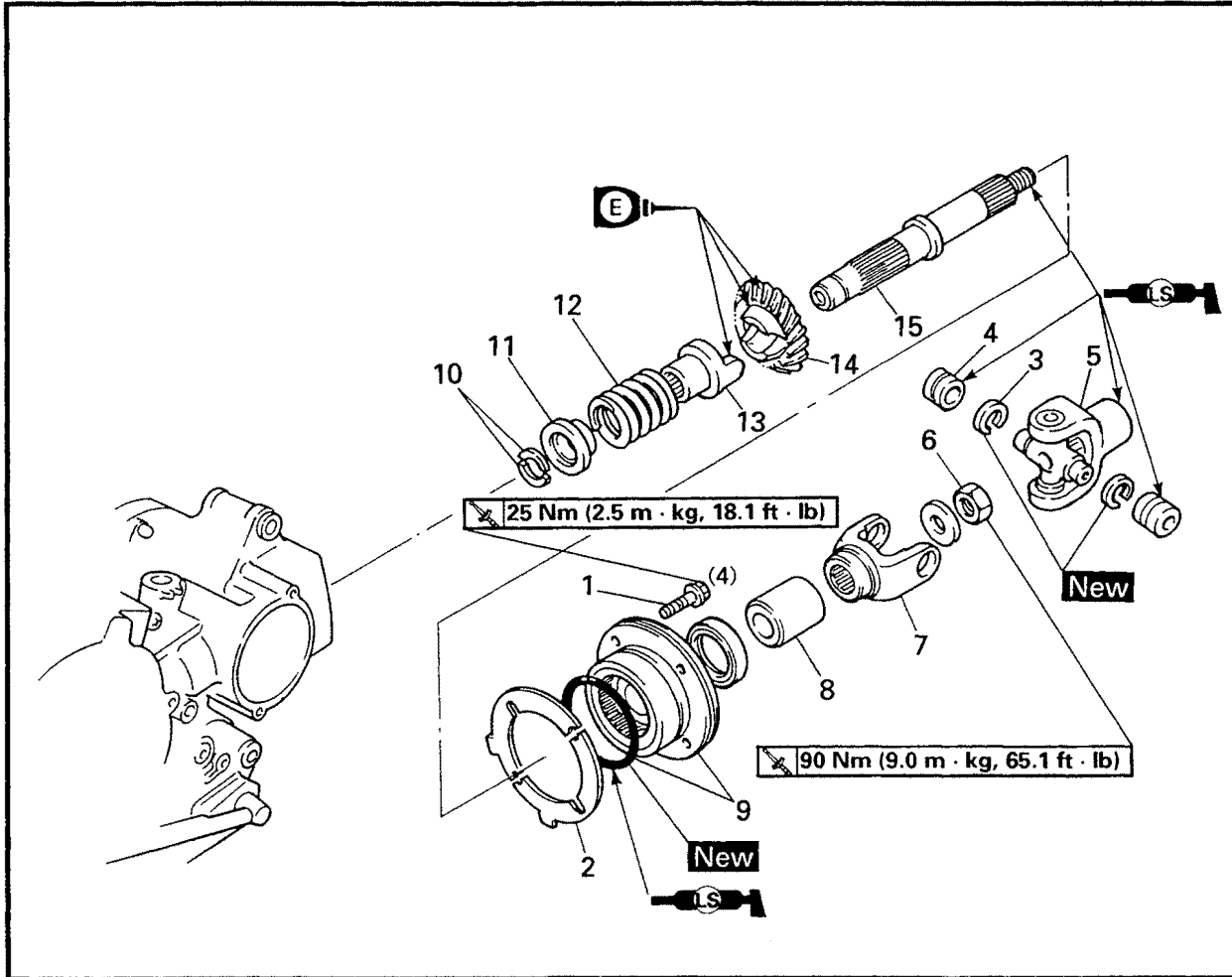

Order	Job name/Part name	Q'ty	Remarks
14	Middle driven pinion gear	1	Refer to "MIDDLE DRIVEN PINION GEAR REMOVAL/INSTALLATION". For installation, reverse the removal procedure.
15	Middle driven shaft	1	



MIDDLE DRIVE PINION GEAR

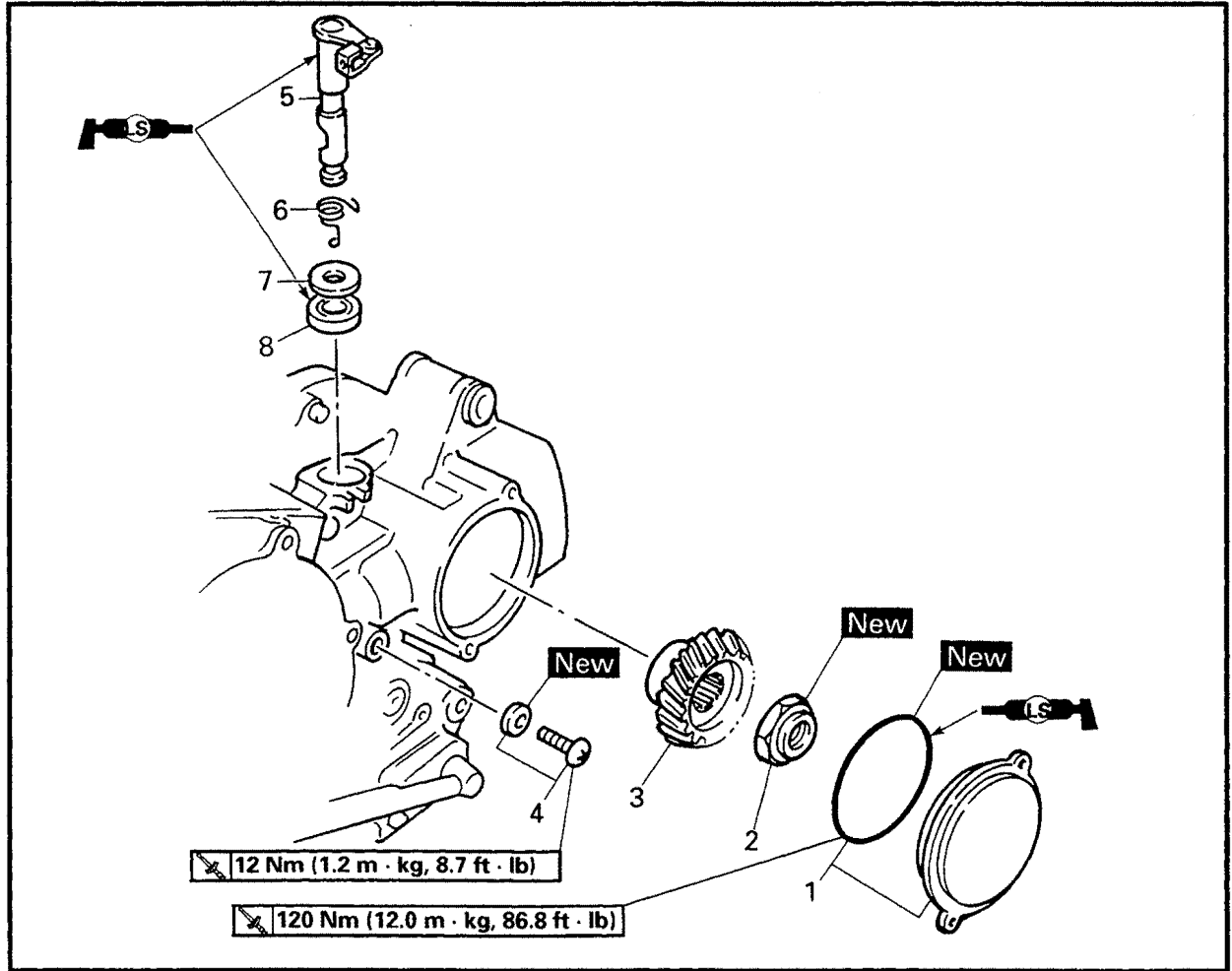

Order	Job name/Part name	Q'ty	Remarks
	Middle drive pinion gear removal		Remove the parts in the order below.
1	Middle gear cover/O-ring	1/1	Refer to "MIDDLE DRIVE PINION GEAR REMOVAL/INSTALLATION".
2	Nut	1	
3	Middle drive pinion gear	1	
4	Screw/gasket	1/1	
5	Push lever axle	1	
6	Torsion spring	1	
7	Washer	1	
8	Oil seal	1	
			For installation, reverse the removal procedure.

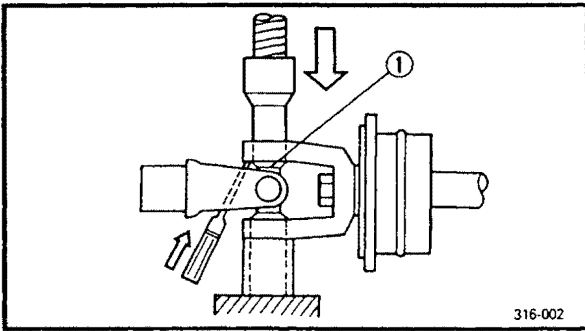

MIDDLE DRIVEN PINION GEAR REMOVAL

1.Remove:

- Universal joint

Disassembly steps:

- Remove the circlips ①.
- Place the universal joint in a press.
- Using a suitable diameter pipe beneath the yoke, press the bearing into the pipe as shown.

NOTE:

It may be necessary to lightly tap the yoke with a punch.

- Repeat the steps for the opposite bearing.
- Remove the yoke.

2.Loosen:

- Nut (middle driven shaft) ①

NOTE:

Use the universal joint holder ② to hold the yoke ③.

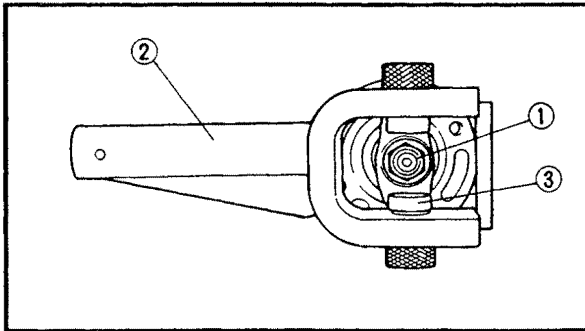

	Universal joint holder: YM-04062, 90890-04062
--	--

3.Remove:

- Bearing housing assembly ①

Removal steps:

- Clean the outside of the middle driven shaft.
- Place the middle driven shaft assembly onto a hydraulic press.

CAUTION:

- Never directly press the shaft end with a hydraulic press, this will result in damage to the shaft thread.
- Install the suitable socket ② on the shaft end to protect the thread from damage.

NOTE:

When the middle driven shaft is removed from the bearing housing assembly, always replace the bearing.

- Press the shaft end, and remove the bearing housing.

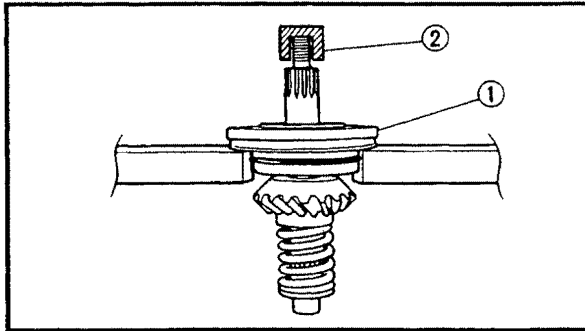

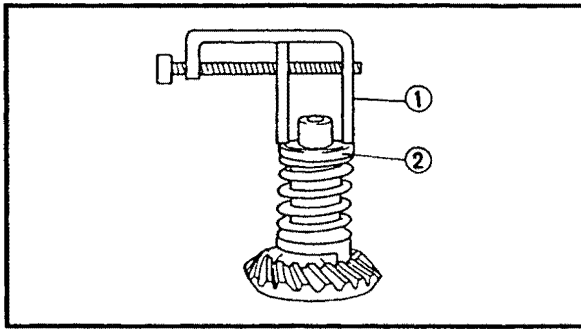

- 4.Remove:
- Spring retainers

NOTE: Attach the damper spring compressor ① on the spring seat ② and compress the damper spring, then remove the spring retainers.



Damper spring compressor:
YM-33286, 90890-04090

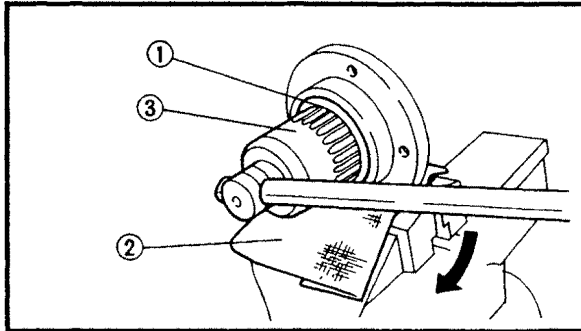

- 5.Remove:
- Bearing retainer ①
 - Bearing

Removal steps:

- Attach the folded rag ②.
- Secure the bearing housing edge in the vise.
- Attach the bearing retainer wrench ③.



Bearing retainer wrench:
YM-04057, 90890-04057

CAUTION:

The middle driven shaft bearing retainer has left-handed threads. To loosen the retainer turn it clockwise.

- Remove the bearing retainer and bearing.

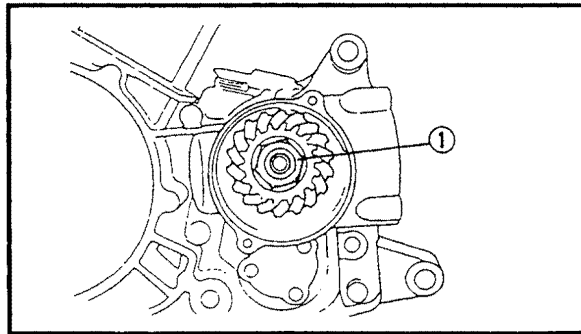

MIDDLE DRIVE PINION GEAR REMOVAL

- 1.Loosen:
- Nut (middle drive pinion gear) ①

NOTE:

- Flatten the punched position of the middle drive pinion gear nut using the drift punch.
- Put the engine in 1st, and carry out the operation.
- Loosen the nut (middle drive pinion gear) ① while holding the rotor with the sheave holder ②.

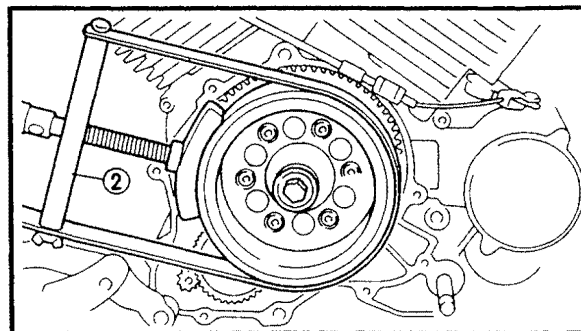

Sheave holder:
YS-01880, 90890-01701

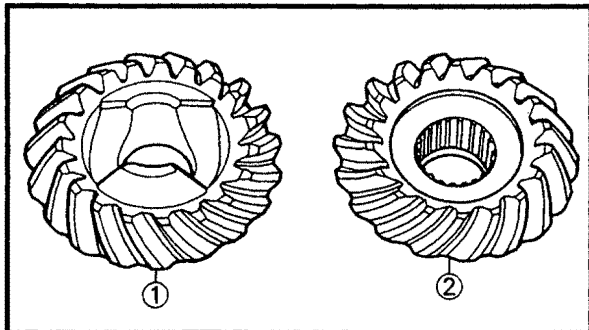
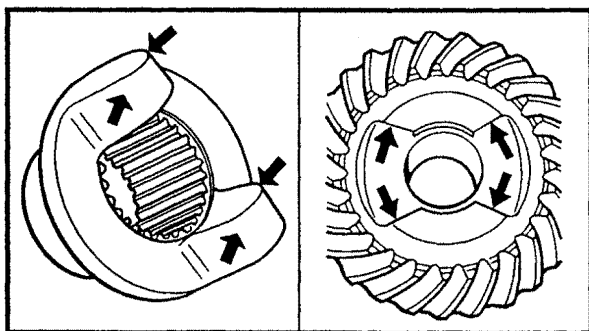

MIDDLE GEAR INSPECTION

1. Inspect:

- Damper cam surface
Wear/scratches → Replace the damper cam as a set.

2. Inspect:

- Damper spring
Damage/cracks → Replace.

3. Inspect:

- Middle driven pinion gear teeth ①
- Middle drive pinion gear teeth ②
Pitting/galling/wear → Replace the middle gear as a set.

4. Inspect:

- Bearing
Pitting/damage → Replace the bearing housing assembly.
- O-rings
Damage → Replace.

5. Check:

- Universal joint movement
Roughness → Replace the universal joint.

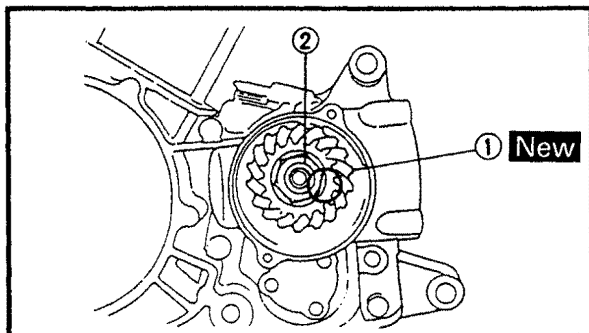

MIDDLE DRIVE PINION GEAR INSTALLATION

1. Install:

- Middle drive pinion gear ①
- Nut ② **New**

120 Nm (12.0 m · kg, 86.8 ft · lb)

NOTE:

- Tighten the nut (middle drive pinion gear) ② while holding the rotor with the sheave holder ③.
- To lock the threads stake them with a center punch.

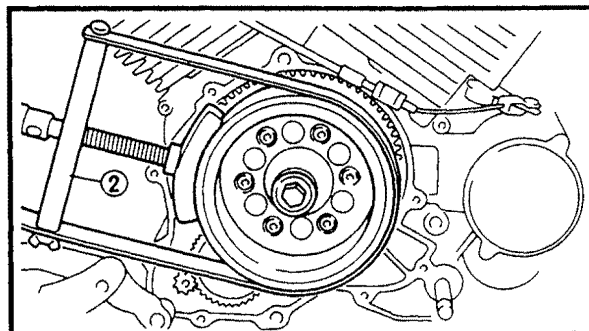

**Sheave holder:
YS-01880, 90890-01701**

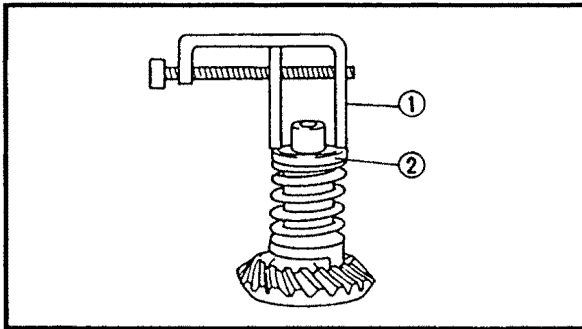

**MIDDLE DRIVEN PINION GEAR
INSTALLATION**

1. Install:
- Spring retainers

NOTE: _____
Attach the damper spring compressor ① on the spring seat ② and compress the damper spring, then install the spring retainers.

	Damper spring compressor: YM-33286, 90890-04090
--	---

2. Install:
- Bearing

Installation steps:

- Install the new bearing by reversing the removal steps.

NOTE: _____
Use a socket ① that matches the diameter of the outer bearing race and the oil seal.

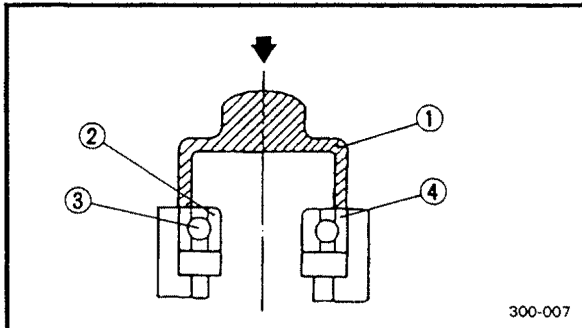

CAUTION: _____
Do not contact the bearing center race ② or balls ③. Contact should be made only with the outer race ④.

3. Install:
- Bearing retainer ①

Install steps:

- Attach the folded rag ②.
- Secure the bearing housing edge in the vise.
- Attach the bearing retainer wrench ③.

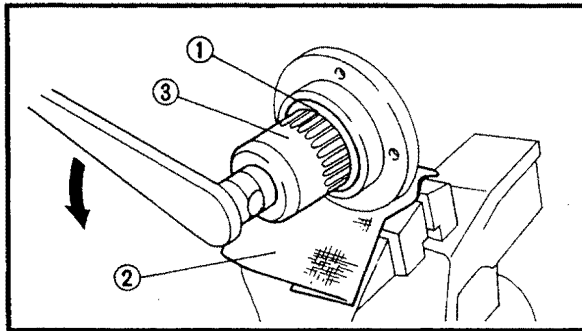

	Bearing retainer wrench: YM-04057, 90890-04057
--	--

- Tighten the bearing retainer.

CAUTION: _____
The middle driven shaft bearing retainer has left-handed threads. To tighten the retainer turn it counterclockwise.

	Bearing retainer: 110 Nm (11.0 m · kg, 79.6 ft · lb)
--	--

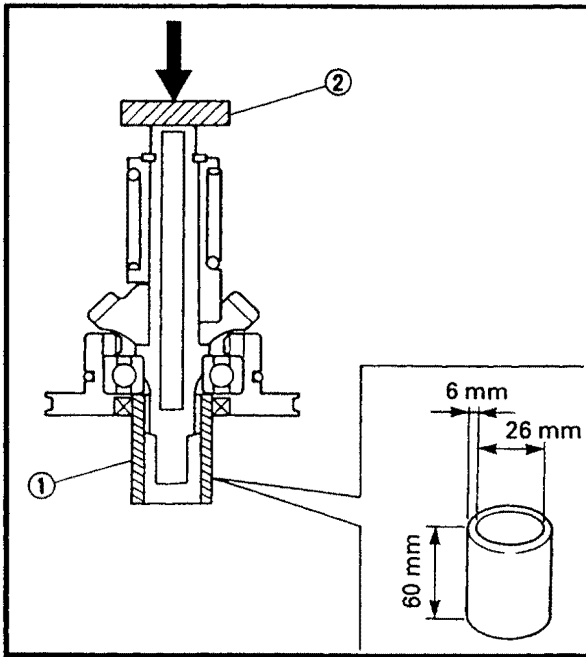

4. Install:

- Middle driven shaft assembly

Install steps:

- Clean the outside of the middle driven shaft and the inside of the bearing.
- Fit the middle driven shaft assembly onto the bearing housing.
- Place the middle driven shaft assembly onto a hydraulic press.

CAUTION:

- Never directly press the shaft end with a hydraulic press, this will result in damage to the shaft thread.
- Install the hand-made tool (1) to protect the bearing and bearing housing from damage.
- Install the wood piece (2) on the shaft end to protect the thread from damage.
- Press the wood piece and secure the middle driven shaft assembly.

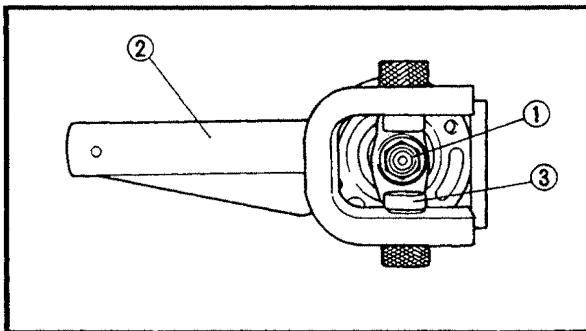

5. Tighten:

- Nut (middle driven pinion gear) (1)

90 Nm (9.0 m · kg, 65.1 ft · lb)

NOTE:

Use the universal joint holder (2) to hold the yoke (3).



**Universal joint holder:
YM-04062, 90890-04062**

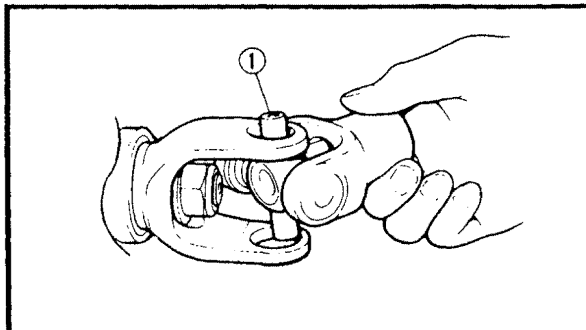

6. Install:

- Yoke (cross joint) (1)
(into the hole on yoke)

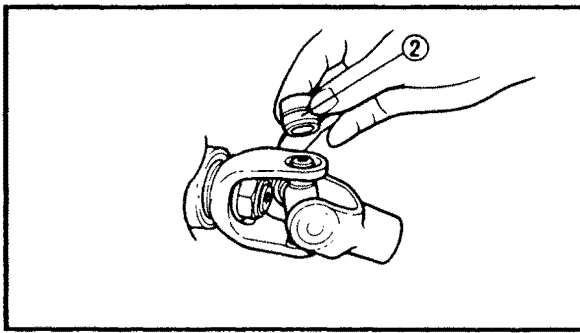

7. Install:

- Bearings ①
(onto the cross joint)

CAUTION:

The needles can easily fall out of their races, so check each bearing. Slide the universal joint yoke back and forth on the bearings. If a needle is out of place the yoke will not go all the way onto the bearing.

8. Using a suitable socket press each bearing into the hole on yoke.

NOTE:

The bearings must be inserted far enough into the cross joint so that the circlips can be installed.

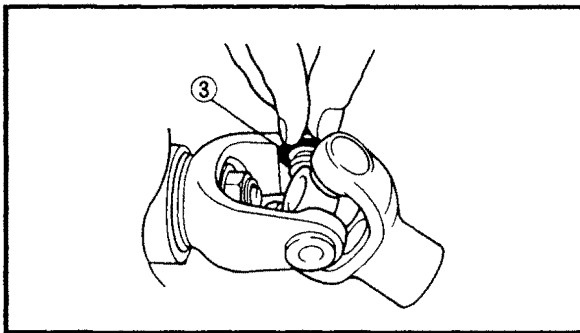

9. Install:

- Circlips ③
(into the groove of each bearing)

10. Install:

- Middle driven pinion gear assembly

NOTE:

Just finger tighten the bolts at this stage.

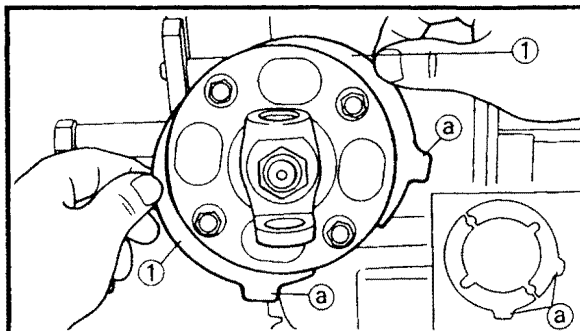

11. Install:

- Shims ①
- Bolts

25 Nm (2.5 m · kg, 18.1 ft · lb)

NOTE:

When installing the shims, make sure that the tabs ② are positioned correctly.

NOTE:

Before tightening the bolts:

1. Adjust the gear lash of the middle gear. Refer to "GEAR BACKLASH ADJUSTMENT".
2. Check the operation of the middle driven gear.

MIDDLE DRIVE GEAR SHIM SELECTION

NOTE:

Gear positioning is necessary when any of the following parts are replaced.

- Crankcase assembly
- Middle gear assembly

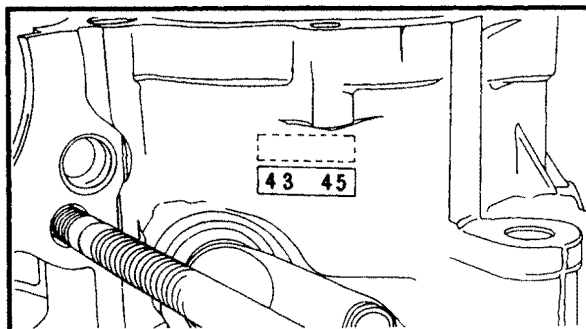
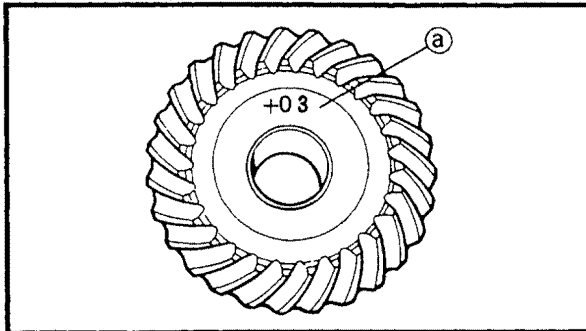
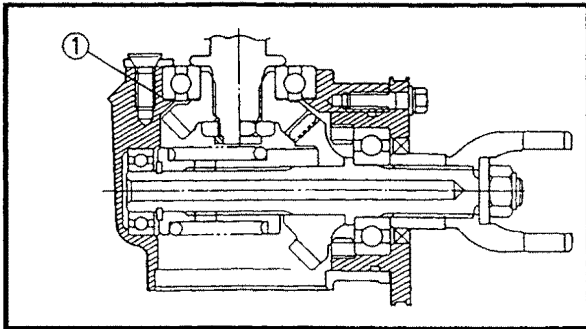

1. Select:

- Middle drive gear shim ①

Middle drive gear shim selection steps:

- Position middle drive gear by using shims ① with their respective thickness calculated from information marked on crankcase, bearing housing and drive gear end.

① Shim thickness "A"

- To find shim thickness "A" use following formula:

Middle drive pinion gear shim thickness:

$$"A" = \textcircled{a} - \textcircled{b}$$

Where:

① = a numeral (usually a decimal number) on the middle drive pinion gear is either added to or subtracted from "44".

② = a numeral (usually a decimal number) on the left crankcase specifies a thickness of "43.5".

Example:

- 1) If the middle drive pinion gear is marked "+03"
 ① is 44.03
- 2) If the crankcase (left) is marked "43.45"
 ② is 43.45
- 3) Therefore, the shim thickness is 0.58 mm



A = 44.03 – 43.45
= 0.58

6) Round off hundredths digit and select appropriate shim(s).

In the example above, the calculated shim thickness is 0.58 mm. The chart instructs you, however, to round off 8 to 10.

Hundredths	Round value
0, 1, 2, 3, 4	0
5, 6, 7, 8, 9	10

Shims are supplied in the following thickness.

 Middle drive pinion gear shim		
Thickness (mm)	0.20 0.30	0.40

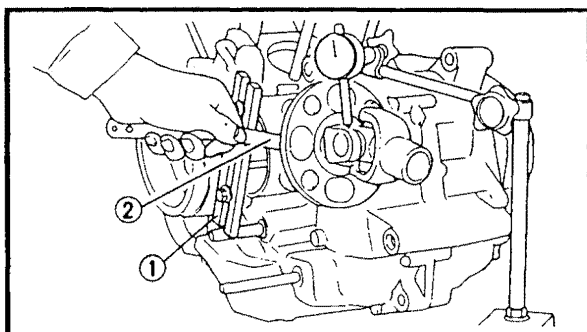

GEAR BACKLASH ADJUSTMENT

1.Install:

- Middle gear backlash tool ①

NOTE:

This tool will prevent the drive axle from turning.

 Middle gear backlash tool: YM-33222, 90890-04080
--

2.Install:

- Bolts (driven gear bearing housing)

NOTE:

- Just finger tighten the bolts at this stage.
- Clearance between the crankcase and the driven bearing housing should be about 2 mm.
- Measure the gap with a feeler gauge ②.



3.Position:

- Dial gauge
(onto the outside edge of the universal joint)

NOTE: _____

Be sure that the gauge is positioned over the centerline of the yoke bearing hole.

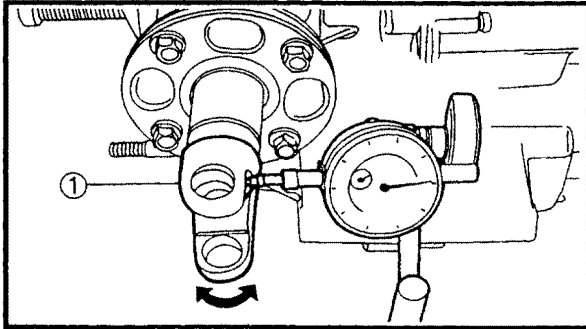

4.Rotate:

- Universal joint ①

NOTE: _____

Move the universal joint gently back and forth.

5.Measure:

- Gear backlash
Over specification → Follow the next steps
Under or same specification → Incorrect
Check for faulty parts and/or reassemble the bearing housing.



Backlash (gear):

0.05 ~ 0.10 mm (0.002 ~ 0.004 in)

CAUTION: _____

Do not hammer the universal joint or the collapsible collar of the driven pinion gear may be distorted. This will result in a change in the standard spinning torque, requiring replacement of the collapsible collar and reassembly of the driven gear assembly.

NOTE: _____

Check the gear backlash at four positions. Rotate the universal joint 90° each time and repeat the gear backlash check.

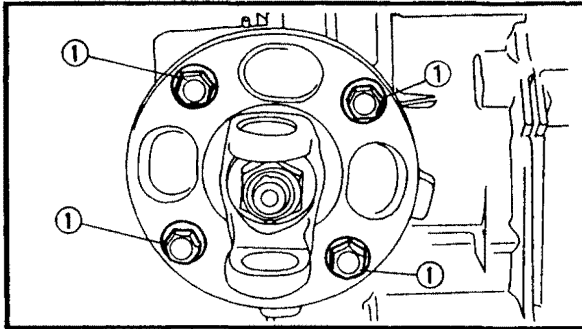

6. Tighten:

- Bolts (driven gear bearing housing) ①

25 Nm (2.5 m · kg, 18.1 ft · lb)

NOTE:

Tighten the bolts carefully, one thread turn at a time, only. Push in the bearing housing and tighten the bearing housing bolts.

CAUTION:

Do not overtighten the bearing housing bolts or you may obtain too little gear backlash and cause damage to the gears. If over tightened, loosen the three bolts so that the crankcase/bearing housing clearance is about 2 mm and repeat all previous steps.

7. Repeat steps #4 and #5 until the correct gear backlash is achieved.



Backlash (gear):
0.05 ~ 0.10 mm (0.002 ~ 0.004 in)

8. Measure:

- Crankcase/bearing housing clearance
Use a feeler gauge

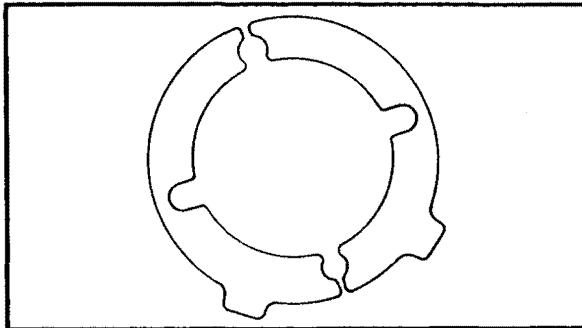

9. Select:

- Shim(s)

Selection steps:

- For example, the clearance between the crankcase and the bearing housing is 0.46 mm (0.018 in).
- The shim can only be selected in 0.05 mm (0.001 in) increments, round off the hundredths digit and select the appropriate shim(s).

Hundredths	Rounded value
0, 1, 2	0
3, 4, 5, 6,	5
7, 8, 9	10



- Shims are supplied in the following thicknesses.

	Middle drive pinion gear shim:
Thickness (mm)	0.10, 0.15, 0.20

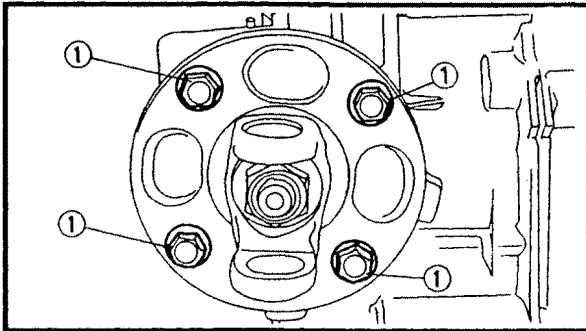

10. Tighten:

- Bolts (driven gear bearing housing) ①

 **25 Nm (2.5 m · kg, 18.1 ft · lb)**

11. Measure:

- Gear backlash



CARBURETION

CARBURETOR

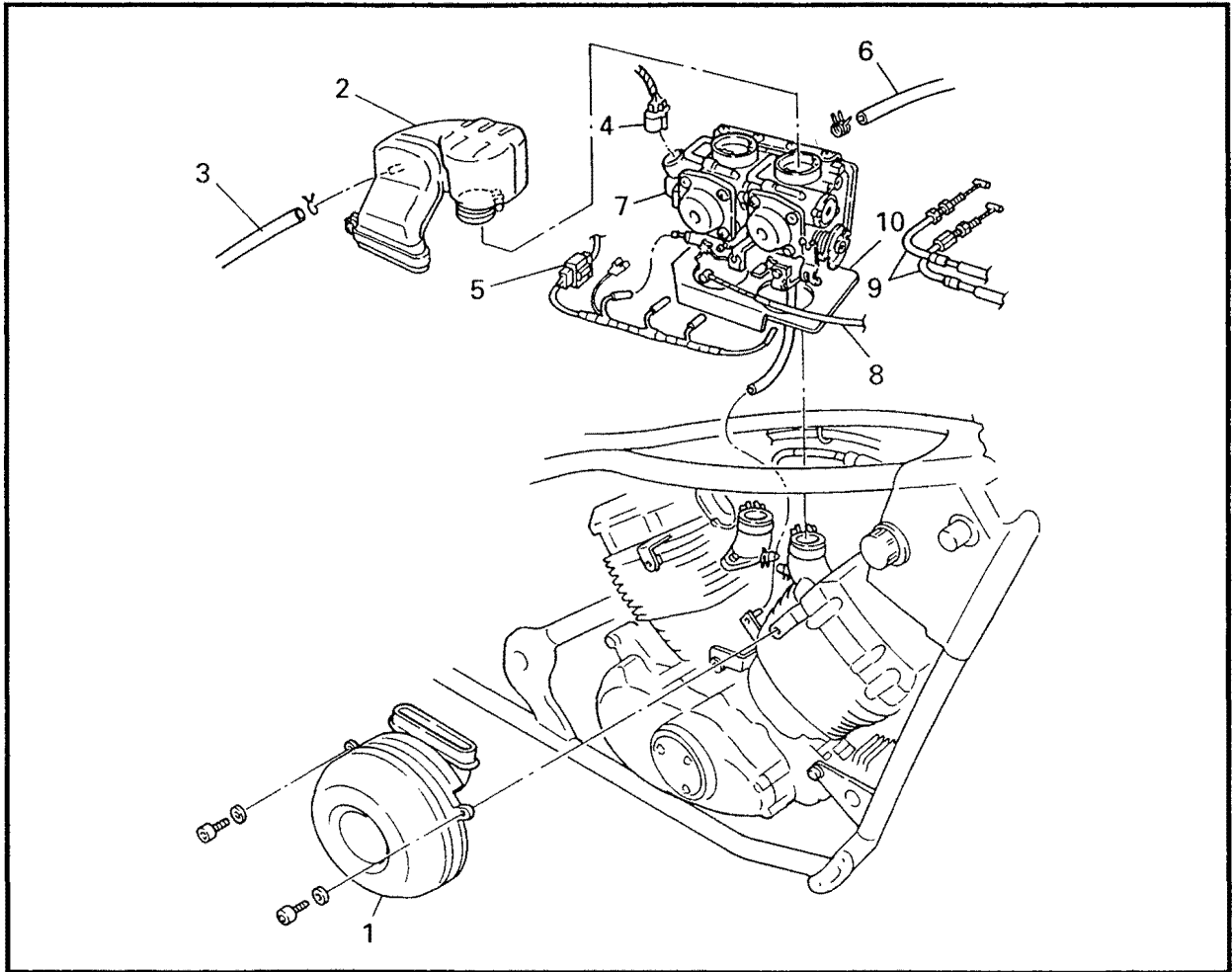

5

Order	Job name/Part name	Q'ty	Remarks
	Carburetor removal		Remove the parts in the order below. Refer to "FUEL TANK AND SEATS" in CHAPTER 3.
	Fuel tank		
1	Air filter case assembly	1	
2	Air duct	1	
3	Cylinder head breather hose	1	Disconnect
4	Throttle position sensor lead	1	
5	Thermo switch lead	1	
6	Fuel hose	1	
7	Carburetor assembly	1	
8	Starter cable	1	NOTE: _____
9	Throttle cables	2	After removing the carburetor assembly, remove the starter cable and throttle cables.
10	Cover	1	_____
			For installation, reverse the removal procedure.

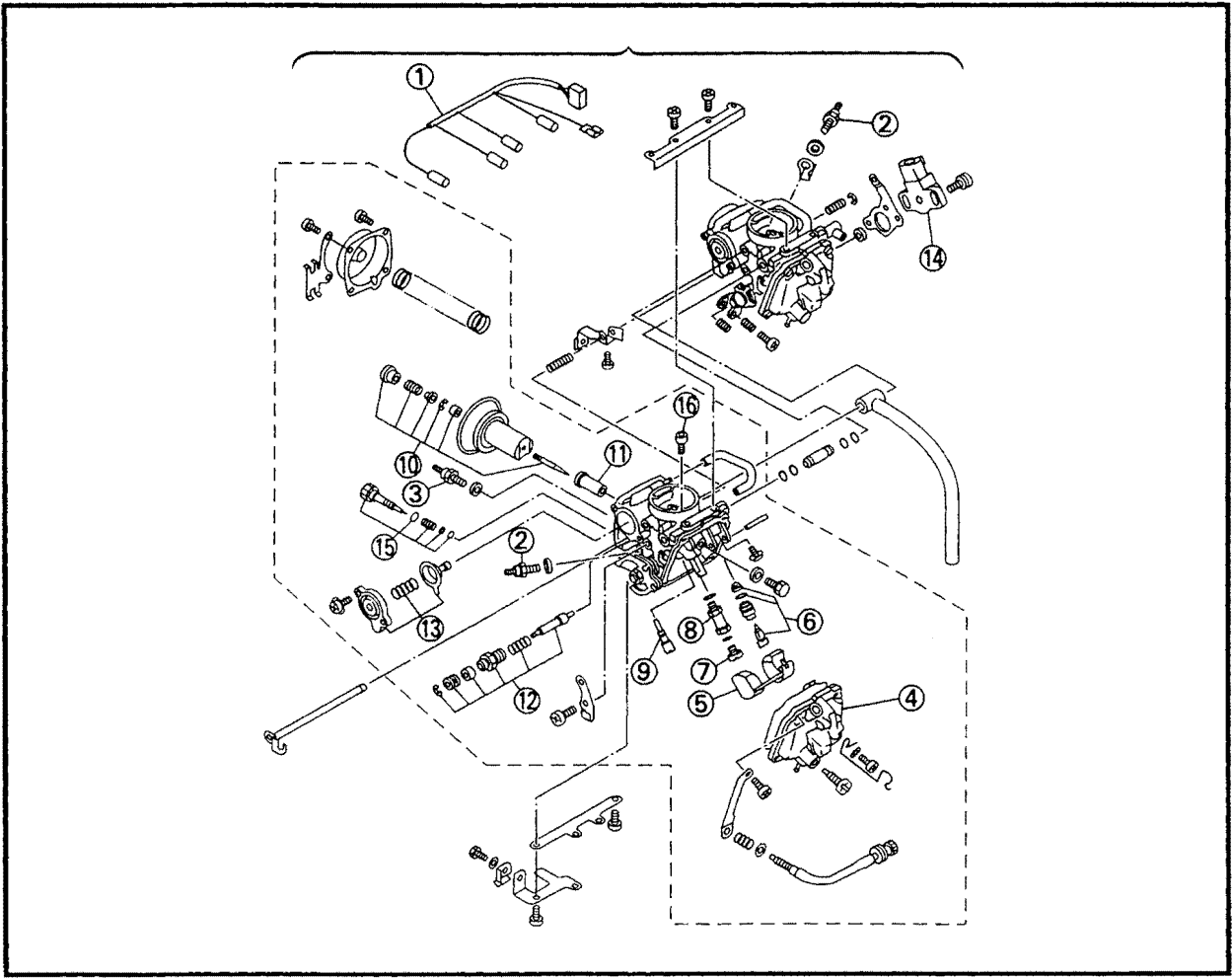

Order	Job name/Part name	Q'ty	Remarks
	Carburetor disassembly		Disassemble the parts in the order below.
①	Carburetor heater lead	1	
②	Carburetor heaters 1	2	12V 15W
③	Carburetor heaters 2	2	12V 30W
④	Float chamber	1	
⑤	Float	1	
⑥	Needle valve set	1	
⑦	Main jet	1	
⑧	Jet holder	1	
⑨	Pilot jet	1	
⑩	Jet needle set	1	Refer to "CARBURETOR ASSEMBLY".
⑪	Needle jet	1	
⑫	Starter plunger set	1	

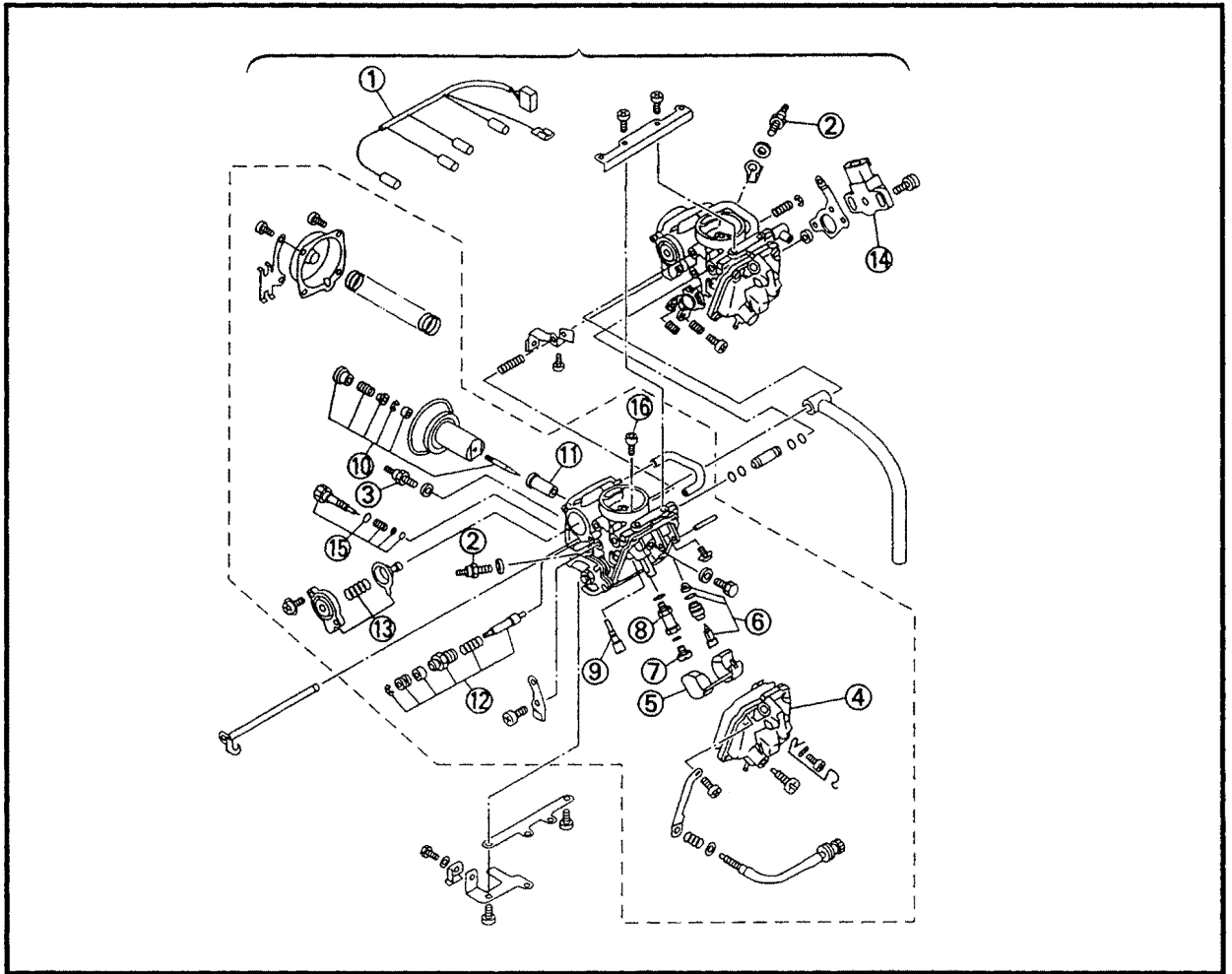

Order	Job name/Part name	Q'ty	Remarks
⑬	Diaphragm set	1	Refer to "CARBURETOR ASSEMBLY".
⑭	Throttle position sensor	1	Refer to "THROTTLE POSITION SENSOR (TPS) INSPECTION AND ADJUSTMENT".
⑮	Pilot screw	1	Refer to "CARBURETOR ASSEMBLY".
⑯	Main air jet	1	For assembly, reverse the disassembly procedure.

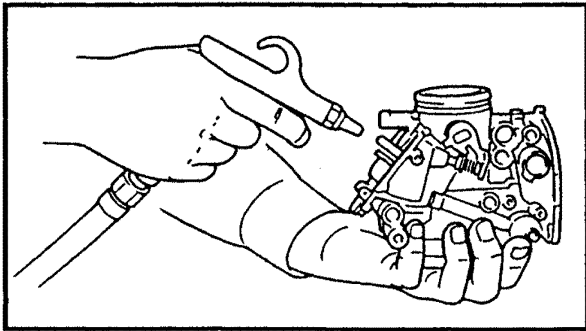

EB600030

CARBURETOR INSPECTION

1. Inspect:

- Carburetor body
- Float chamber
- Jet housing
 - Cracks/damage → Replace.
- Fuel passage
 - Blockage → Clean as indicated.
- Carburetor float chamber body
 - Contamination → Clean.

Cleaning steps:

- Wash the carburetor in a petroleum based solvent. (Do not use any caustic carburetor cleaning solution.)
- Blow out all of the passages and jets with compressed air.

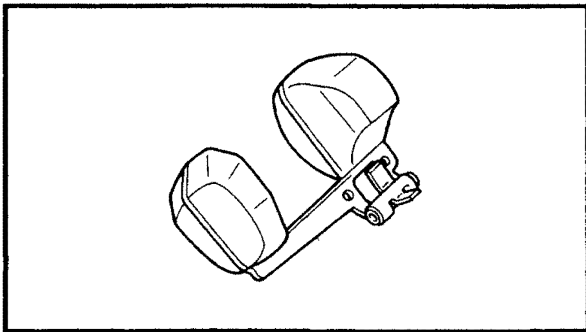

2. Inspect:

- Float
 - Damage → Replace.

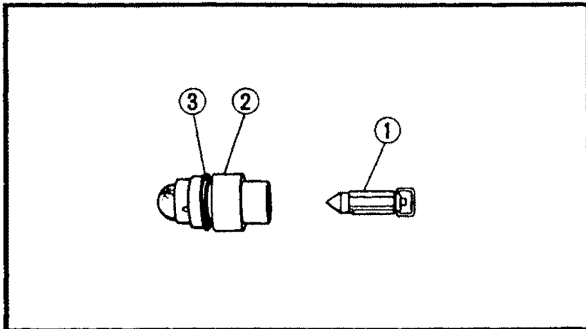

3. Inspect:

- Needle valve ①
- Valve seat ②
- O-ring ③
 - Contamination/wear/damage → Replace as a set.

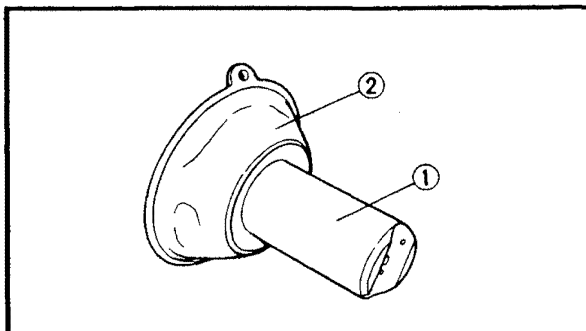

4. Inspect:

- Piston valve ①
 - Scratches/wear/damage → Replace.
- Rubber diaphragm ②
 - Tears → Replace.

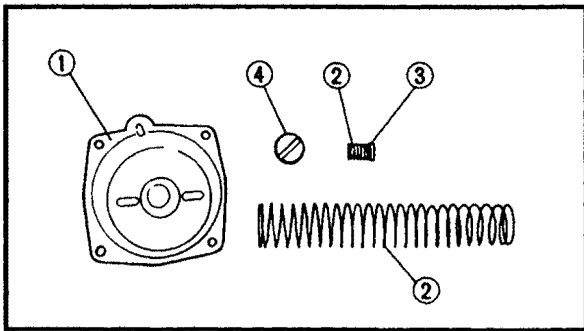

5. Inspect:
- Vacuum chamber cover ①
 - Springs ②
 - Plastic bushing ③
 - Plastic screw cap ④
- Cracks/damage → Replace.

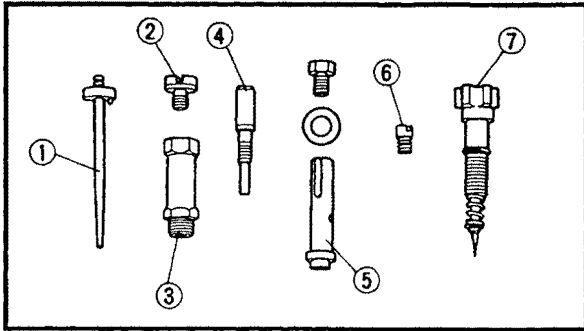

6. Inspect:
- Jet needle ①
 - Main jet ②
 - Main jet holder ③
 - Pilot jet ④
 - Needle jet ⑤
 - Pilot air jet ⑥
 - Pilot screw ⑦
 - Starter plunger
- Bends/wear/damage → Replace.
Blockage → Blow out the jets with compressed air.

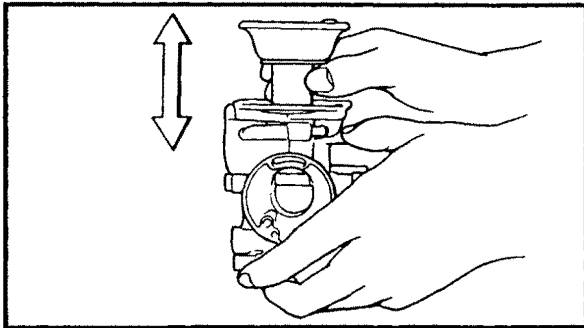

7. Check:
- Free movement
- Insert the throttle valve into the carburetor body and check for free movement.
Sticks/tight → Replace.

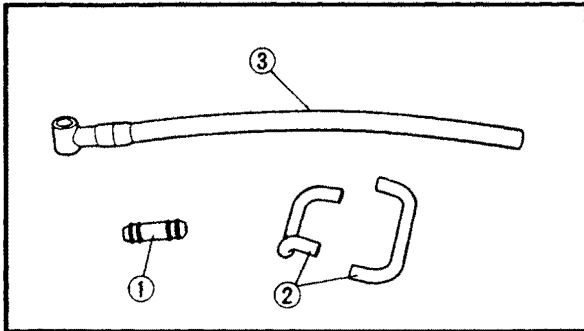

8. Inspect:
- Joints (fuel) ①
 - Joints (air vent hose-vacuum chamber) ②
 - Joints (carburetor breather hose) ③
- Cracks/damage → Replace.

CARBURETOR ASSEMBLY

CAUTION: Before reassembling, wash all of the parts in a clean petroleum based solvent.

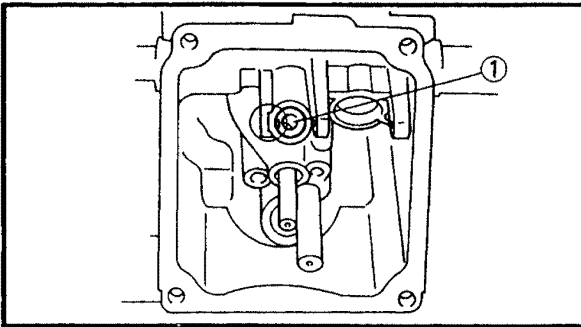

- 1.Install:
- Needle jet ①

NOTE:

- Align the groove on the needle jet with the projection on the carburetor body.
- Install the needle jet from the piston valve side.

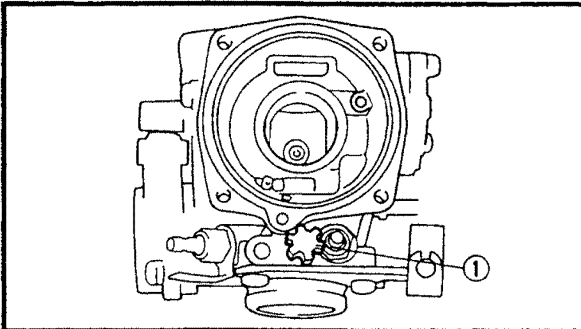

- 2.Install:
- Pilot screw ①



Pilot screw (turns out):
2-1/2

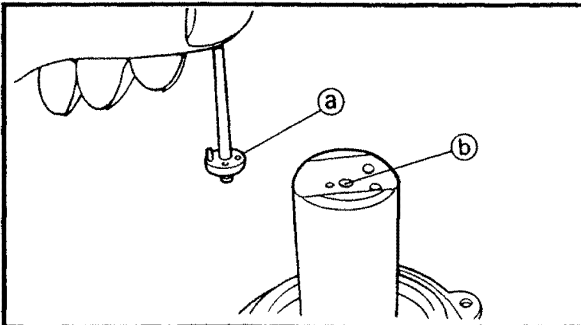

- 3.Install:
- Jet needle

NOTE:

Align the projection ① on the plastic stopper with the hole ② in the piston valve.

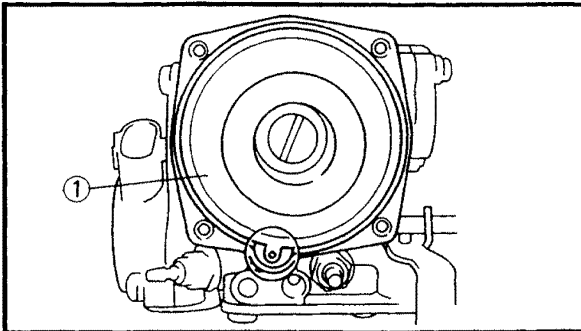

- 4.Install:
- Diaphragm ①

NOTE:

Match the tab on the diaphragm to the recess in the carburetor body.

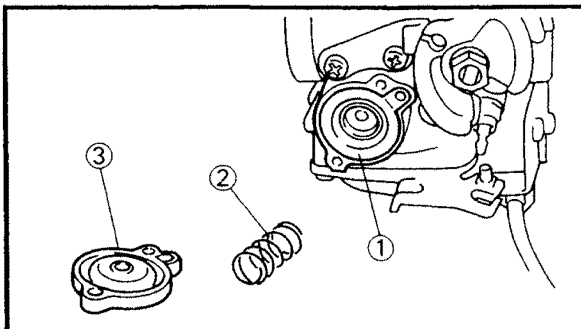

- 5.Install:
- Diaphragm ①
 - Compression spring ②
 - Cover ③

NOTE:

Match the tab on the diaphragm to the recess in the carburetor body.

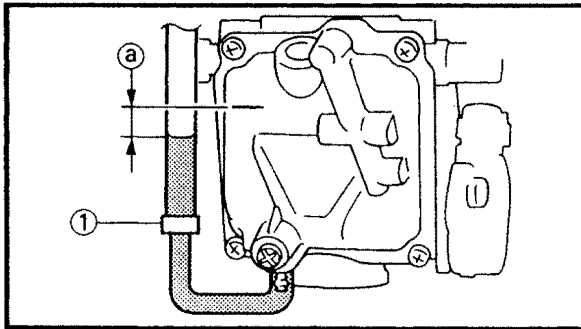

FUEL LEVEL ADJUSTMENT

1. Measure:

- Fuel level (a)
- Out of specification → Adjust

	<p>Fuel level: 7.5 ~ 8.5 mm (0.3 ~ 0.33 in) (below the float chamber line)</p>
--	---

Measurement and adjustment steps:

- Place the motorcycle on a level surface.
- Put the motorcycle on a suitable stand to ensure that the carburetor assembly is positioned vertically.
- Connect the fuel level gauge (1) to the drain pipe.

	<p>Fuel level gauge: YM-01312-A, 90890-01312</p>
--	---

- Loosen the drain screw (2).
- Hold the gauge vertically next to the float chamber line (b).
- Measure the fuel level with the gauge.
- If the fuel level is incorrect, adjust it.
- Remove the carburetor assembly.
- Inspect the valve seat and needle valve.
- If either is worn, replace them both.
- If both are fine, adjust the float level by slightly bending the float tang (3).
- Install the carburetor assembly.
- Check the fuel level again.

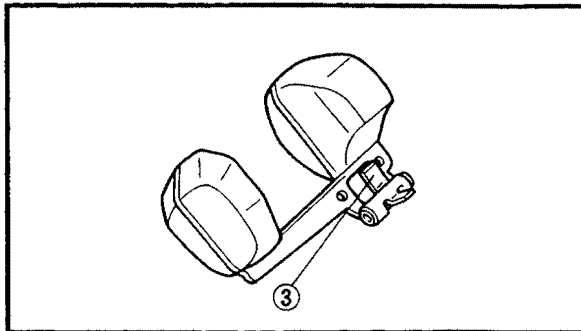
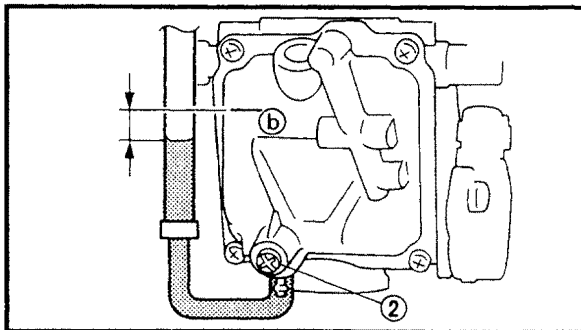

**THROTTLE POSITION SENSOR (TPS)
INSPECTION AND ADJUSTMENT**

NOTE: _____
Before adjusting the TPS, the idling speed should be properly adjusted.

1. Inspect:

- TPS resistance

Inspect steps:

- Disconnect the TPS coupler.
- Remove the TPS from the carburetor.
- Connect the pocket tester ($\Omega \times 1k$) to the TPS connector.

Tester (+) lead → Black terminal ①
Tester (-) lead → Blue terminal ②

- Check the TPS resistance.

 **TPS resistance "R₁":**
4.0 ~ 6.0 k Ω at 20°C
(Black — Blue)

Out of specification → Replace the TPS.

- Connect the pocket tester ($\Omega \times 1k$) to the TPS connector.

Tester (+) lead → Yellow terminal ③
Tester (-) lead → Black terminal ①

- While slowly turning the throttle check the TPS resistance.

 **TPS resistance "R₂":**
0 ~ 5 ± 1.0 k Ω at 20°C
(Yellow — Black)

Out of specification → Replace the TPS.

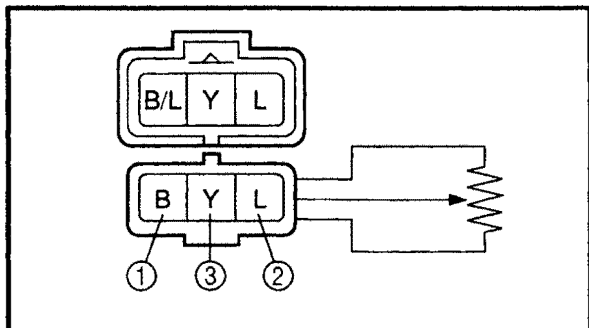

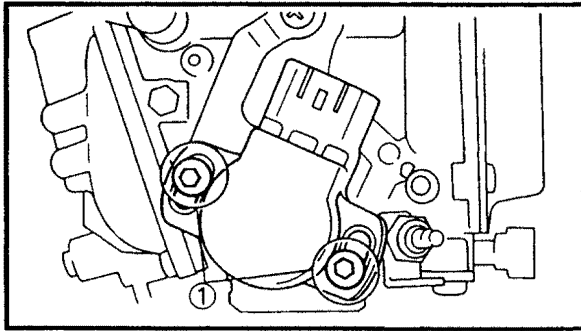

2.Adjust:

- TPS position

Adjustment steps:

- Loosen the TPS mounting screws ①.
- Adjust the TPS resistance by turning the sensor body to the right or left. Stop turning the sensor body when the specified resistance is indicated on the tester.

<p>Resistance when the throttle is closed = Resistance "R₁" × (0.13 ~ 0.15)</p>

Example:

- If "R₁" = 5 kΩ:
 $5 \times (0.13 \sim 0.15) = 0.65 \sim 0.75$
 The specified resistance when the throttle is closed is 650 ~ 750 Ω.
- Tighten the TPS mounting screws.
- Detach the pocket tester leads and connect the TPS connector.



EB601000

AIR INDUCTION SYSTEM (AIS)

AIR INJECTION

This system burns the unburned exhaust gases by injecting fresh air (secondary air) at the exhaust port. This is to reduce the output of the hydrocarbons.

When there is negative pressure around the exhaust port, the reed valve opens and the secondary air flows into the exhaust port. The required temperature for burning the unburned exhaust gases is approximately 600° to 700°C.

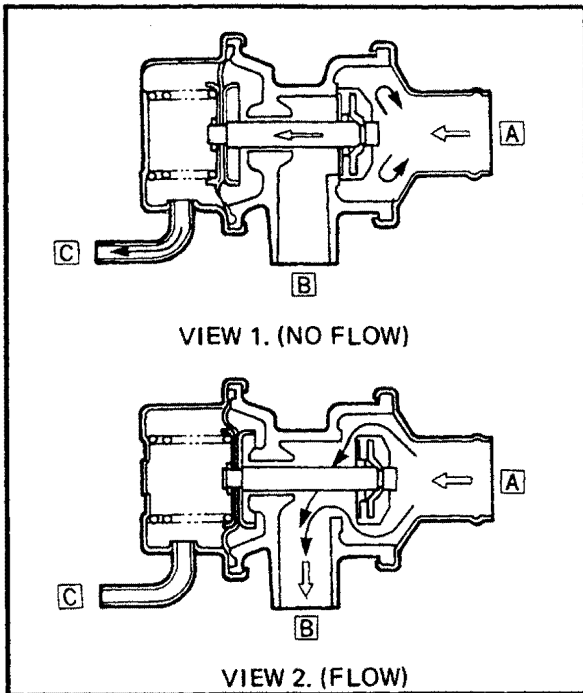

AIR CUT-OFF VALVE

The air cut-off valve is operated by intake gas pressure through the diaphragm. Normally, this valve is opened in order to allow fresh air to flow into the exhaust port. When the throttle is rapidly closed, negative pressure is generated and the valve closes in order to prevent after-burning.

VIEW 1. (NO FLOW)

When decelerating (the throttle closes), the valve will close.

VIEW 2. (FLOW)

During normal operation the valve is open.

- Ⓐ From the air filter
- Ⓑ To the reed valve
- Ⓒ To the carburetor joint

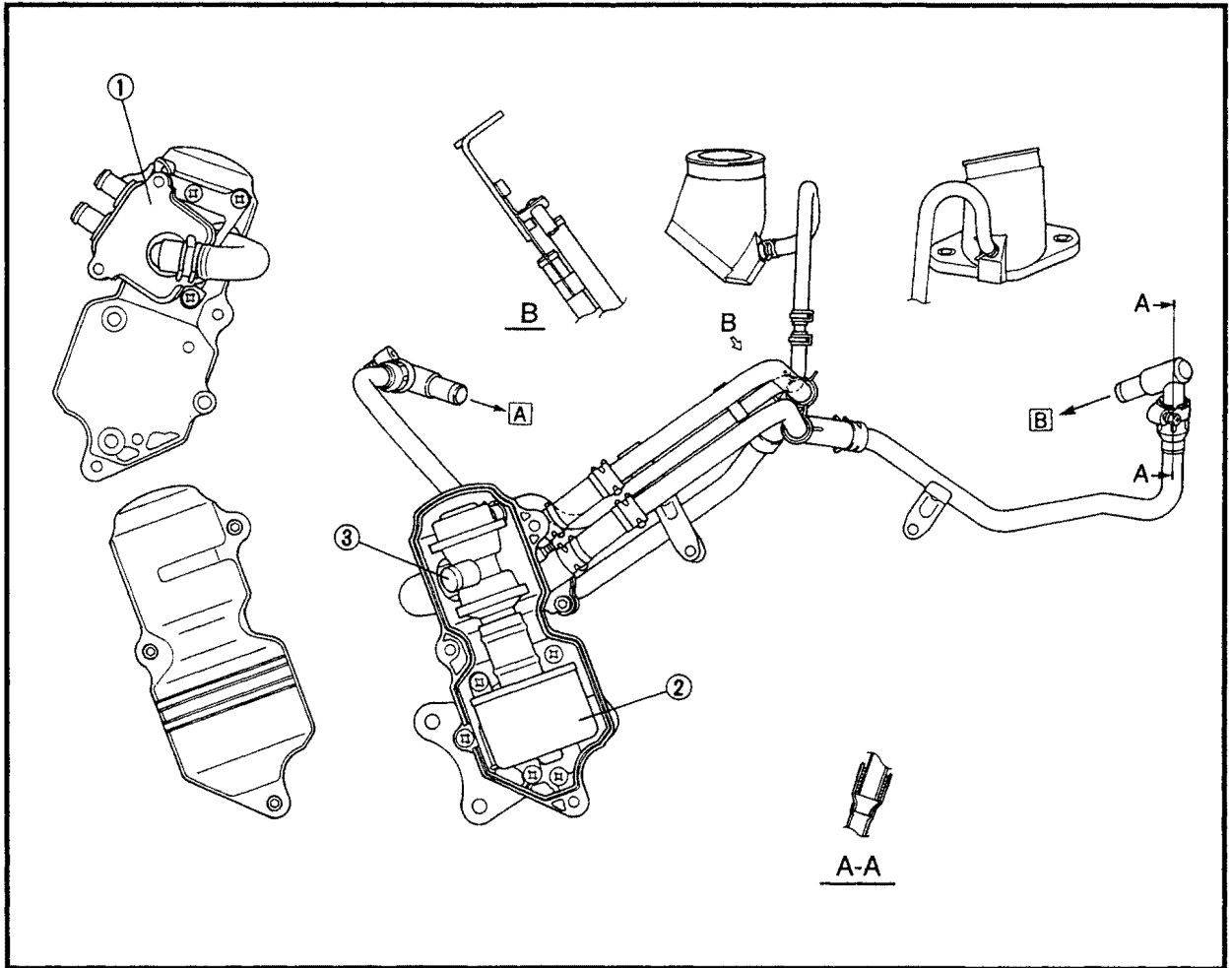

- ① Reed valve
 - ② Air filter
 - ③ Air cut-off valve
- A To the front cylinder head
B To the rear cylinder head

AIR INDUCTION SYSTEM INSPECTION

1. Inspect:
- Hose connections
Poor connections → Properly connect.
 - Hoses
 - Reed valves
 - Air cut-off valve
 - Air filter
Cracks/damage → Replace.
Clogged → Clean.

CHASSIS

FRONT WHEEL AND BRAKE DISC

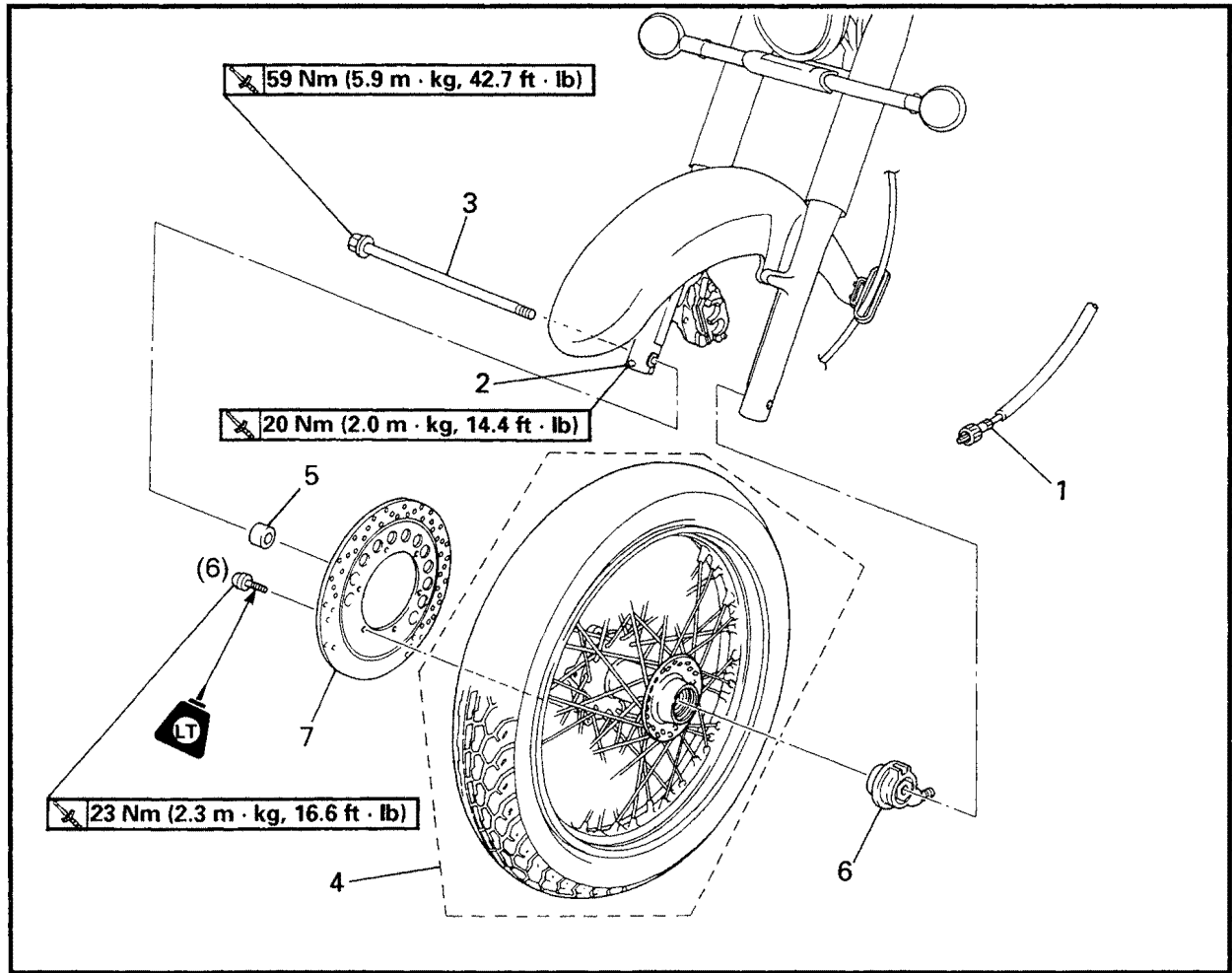

6

Order	Job name/Part name	Q'ty	Remarks
	Front wheel and brake disc removal		Remove the parts in the order below. Stand the motorcycle on a level surface.
			⚠ WARNING Securely support the motorcycle so there is no danger of it falling over.
1	Speedometer cable	1	Disconnect
2	Front wheel axle pinch bolt	1	Loosen
3	Front wheel axle	1	
4	Front wheel assembly	1	Refer to "FRONT WHEEL INSTALLATION".
5	Collar	1	
6	Speedometer gear unit	1	
7	Brake disc	1	
			For installation, reverse the removal procedure.

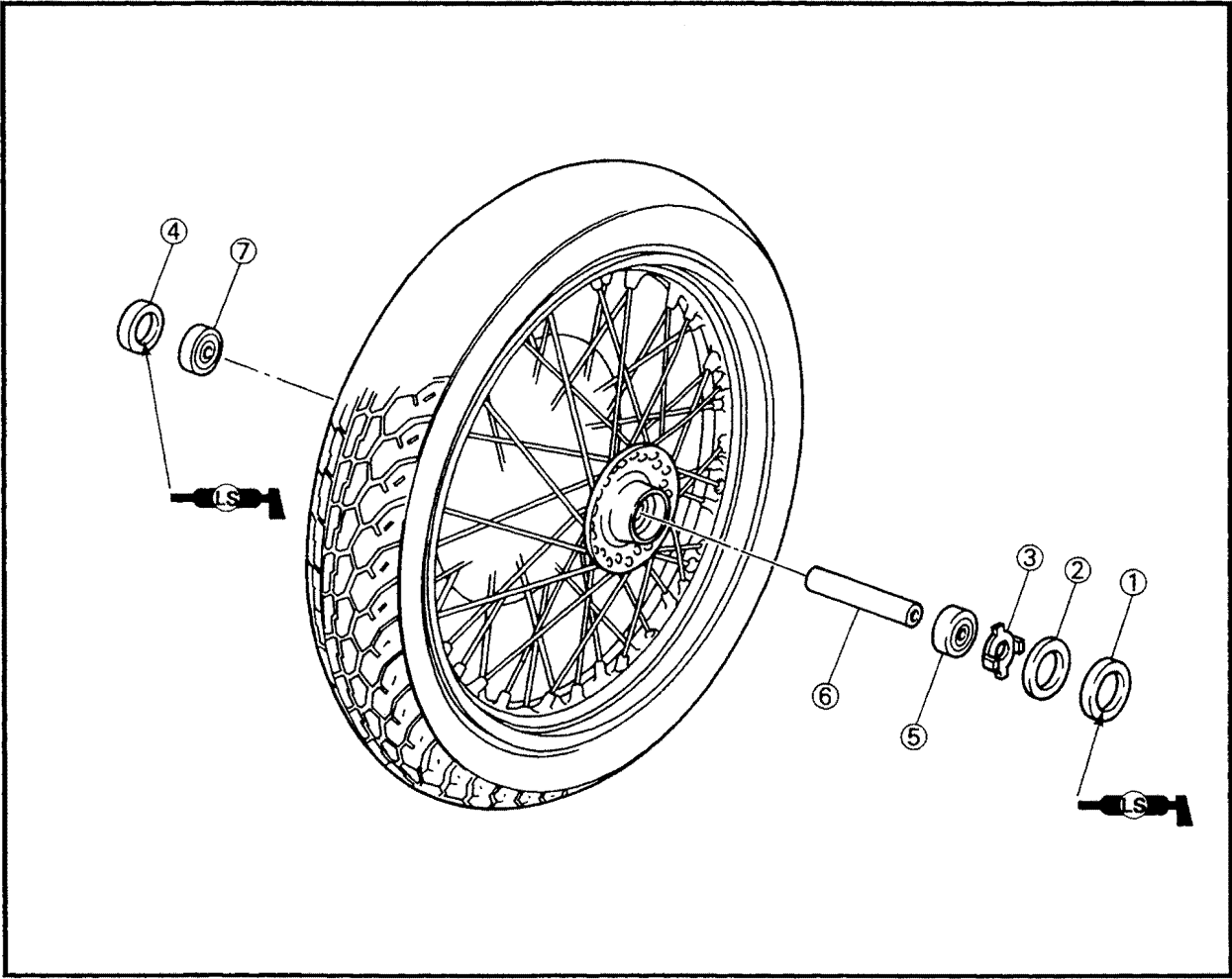

Order	Job name/Part name	Q'ty	Remarks
	Front wheel disassembly		Disassemble the parts in the order below.
①	Oil seals	1	Refer to "FRONT WHEEL DISASSEMBLY/ASSEMBLY". For assembly, reverse the disassembly procedure.
②	Clutch retainer	1	
③	Speedometer clutch	1	
④	Oil seal	1	
⑤	Bearing	1	
⑥	Collar	1	
⑦	Bearing	1	

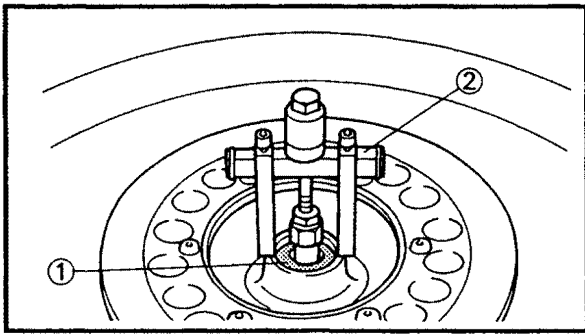

FRONT WHEEL DISASSEMBLY

1.Remove:

- Oil seals
- Bearings ①
- Collar

Removal steps:

- Clean the outside of the front wheel hub.
- Use a flat-head screwdriver to remove the oil seals.

NOTE:

To prevent damage place a rag between the screwdriver and the wheel surface.

- Remove the bearings using a standard bearing puller ②.

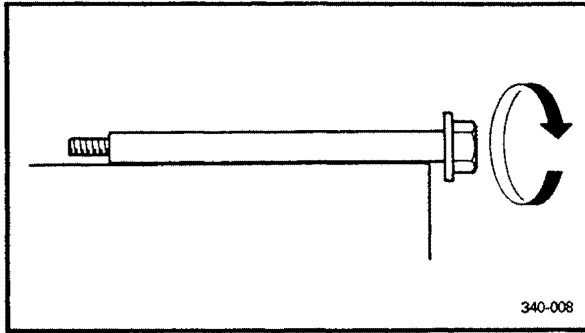

FRONT WHEEL INSPECTION

1.Inspect:

- Front wheel axle
(by rolling it on a flat surface)
Bent → Replace.

⚠ WARNING

Do not attempt to straighten a bent axle.

2.Inspect:

- Front tire
Refer to "TIRE INSPECTION" in CHAPTER 3.
- Front wheel
Refer to "WHEEL INSPECTION" in CHAPTER 3.

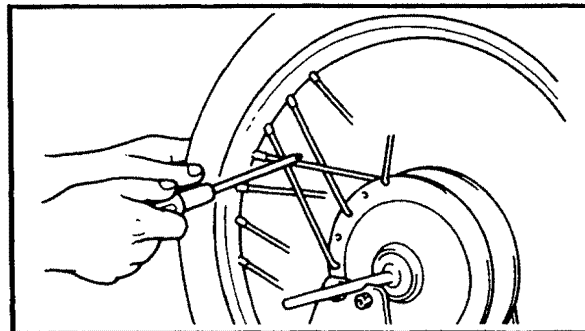

3.Check:

- Spokes
Bends/damage → Replace.
Loose spokes → Retighten.
Turn the wheel and tap the spokes with a screwdriver.

NOTE:

A tight spoke will emit a clear, ringing tone; a loose spoke will sound flat.

4. Tighten:

- Loose spokes  **3 Nm (0.3 m · kg, 2.2 ft · lb)**

NOTE:

After tightening the spokes check the front wheel runout.

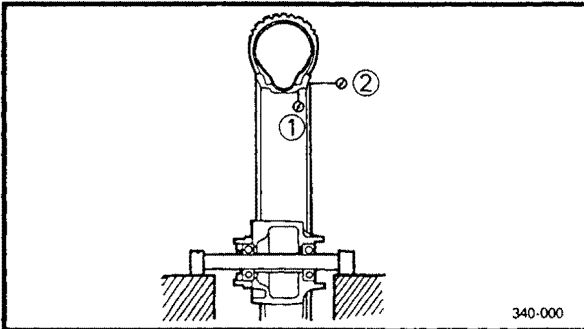

5. Measure:

- Front wheel runout
Over the specified limits → Replace.



Front wheel runout limits:
Radial ①: 2.0 mm (0.08 in)
Lateral ②: 2.0 mm (0.08 in)

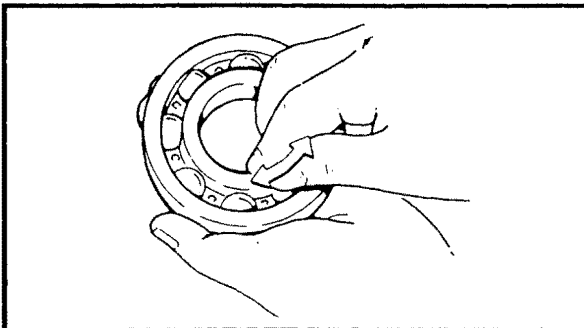

6. Inspect:

- Front wheel bearings
Bearings allow free play in the wheel hub or the wheel does not turn smoothly → Replace.
- Oil seals
Wear/damage → Replace.

BRAKE DISC INSPECTION

1. Inspect:

- Brake disc
Galling/damage → Replace.

2. Measure:

- Brake disc deflection ①
Out of specification → Inspect the wheel runout.
If wheel runout is within the limits, replace the brake disc.



Brake disc maximum deflection:
0.15 mm (0.006 in)

Measuring point 2 mm (0.08 in)

- Brake disc thickness ②
Out of specification → Replace.



Brake disc minimum thickness:
4.5 mm (0.177 in)

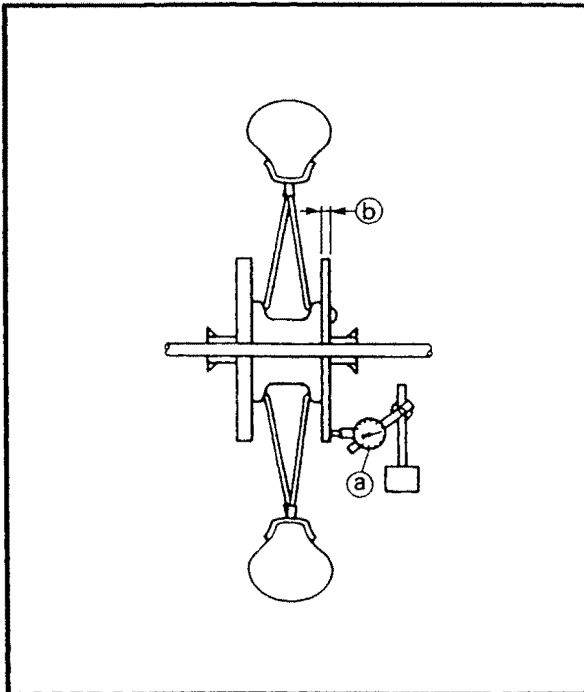

FRONT WHEEL ASSEMBLY

1. Install:

- Collar
- Bearings
- Oil seals

Installation steps:

- Install the new bearings and oil seals by reversing the removal steps.

NOTE:

Use a socket ① that matches the diameter of the outer bearing race and the oil seal.

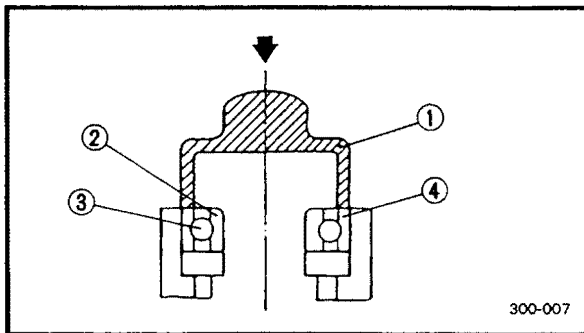

CAUTION:

Do not contact the bearing center race ② or balls ③. Contact should be made only with the outer race ④.

FRONT WHEEL INSTALLATION

1. Install:

- Brake disc ①

 23 Nm (2.3 m · kg, 16.6 ft · lb)

NOTE:

- Apply LOCTITE® to the threads of the brake disc bolts.
- Tighten the brake disc bolts in stages using a crisscross pattern.

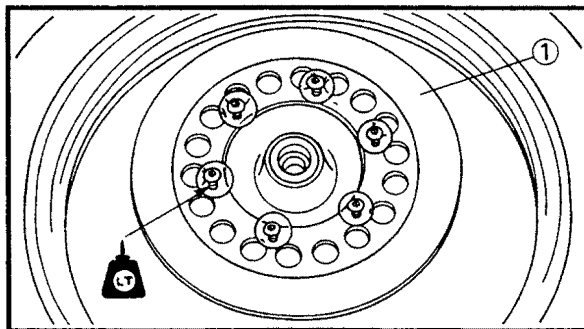

2. Install:

- Speedometer gear unit ①

NOTE:

Be sure that two projections ③ inside the wheel hub mesh with the two slots ② in the gear unit assembly.

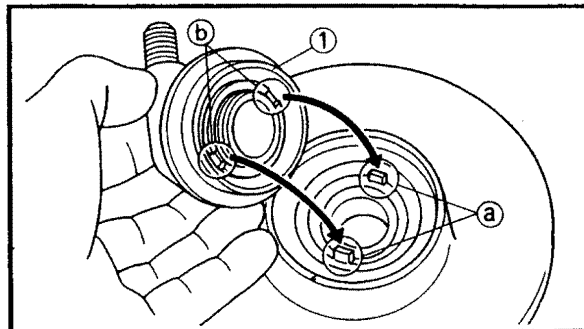

3. Tighten:

- Front wheel
- Front wheel axle

 59 Nm (5.9 m · kg, 42.7 ft · lb)

NOTE:

Be sure that the projection (torque stopper) ③ of the gear unit housing is positioned correctly.

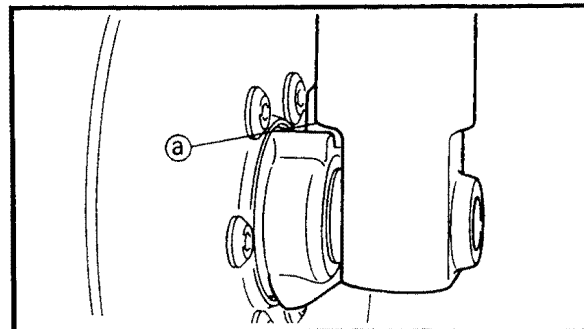

- Axle pinch bolt

 20 Nm (2.0 m · kg, 14.4 ft · lb)

EB700040

**FRONT WHEEL STATIC BALANCE
ADJUSTMENT**

NOTE:

- After replacing the tire and/or rim, the wheel static balance should be adjusted.
- Adjust the front wheel static balance with the brake discs installed.

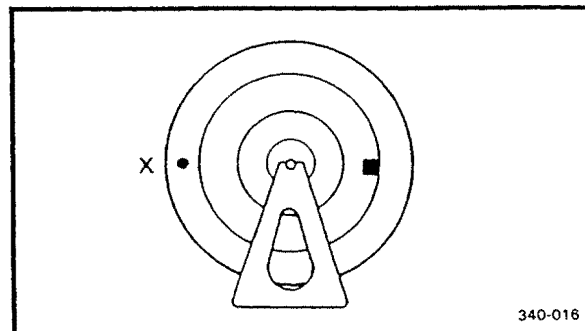
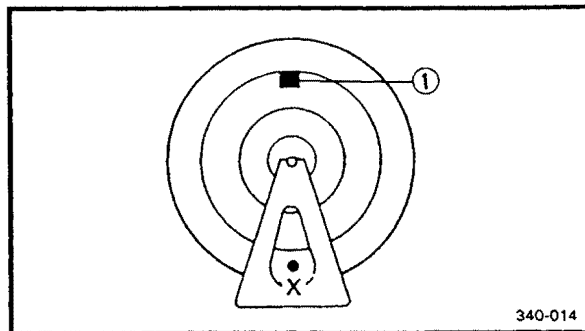
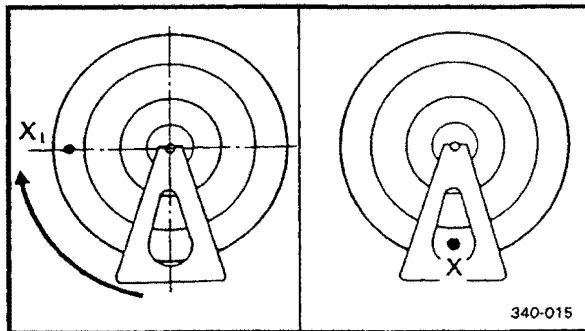
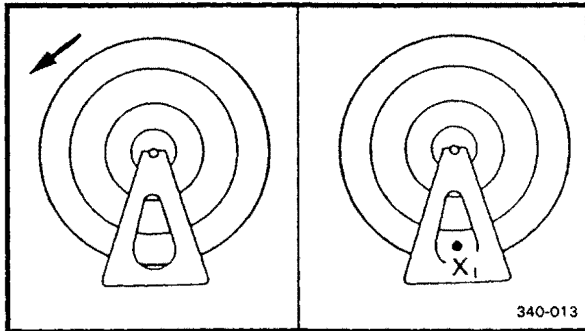

1.Remove:

- Balancing weight

2.Set:

- Front wheel (on a suitable stand)

3.Find:

- Heavy spot

Procedure:

- a. Spin the wheel and wait for it to rest.
- b. Put an "X₁" mark on the wheel's bottom spot.
- c. Turn the wheel so that the "X₁" mark is 90° up.
- d. Release the wheel and wait for it to rest. Put an "X₂" mark on the wheel's bottom spot.
- e. Repeat steps (b), (c) and (d) several times until all the marks come to the same spot.
- f. This spot is the wheel's heavy spot "X".

4.Adjust:

- Front wheel static balance

Adjusting steps:

- Install a balancing weight ① onto the rim exactly opposite to the heavy spot "X".

NOTE:

Start with the smallest weight.

- Turn the wheel so that the heavy spot is 90° up.
- Check that the heavy spot is at rest there. If not, try another weight until the wheel is balanced.

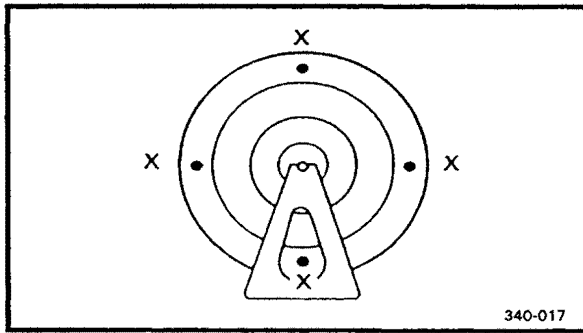

5.Check:

- Front wheel static balance

Checking steps:

- Turn the wheel so that it comes to each point as shown.
- Check that the wheel is at rest at each point. If not, readjust the front wheel static balance.

FRONT BRAKE
FRONT BRAKE PADS

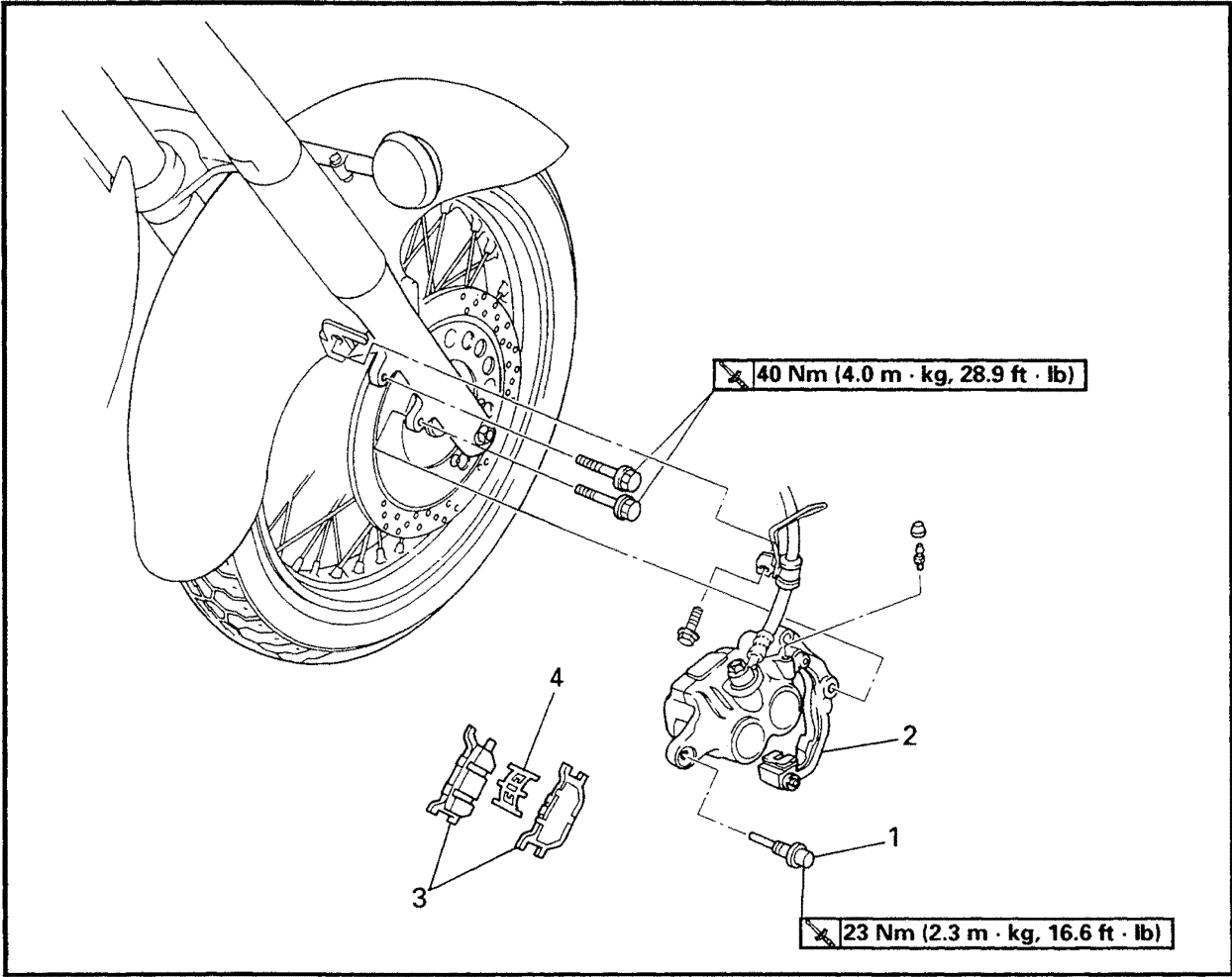

Order	Job name/Part name	Q'ty	Remarks
	Front brake pad removal		Remove the parts in the order below.
1	Retaining bolt	1	Refer to "BRAKE PAD REPLACEMENT".
2	Brake caliper	1	
3	Brake pads	2	
4	Pad spring	1	
			For installation, reverse the removal procedure.



CAUTION:

Disc brake components rarely require disassembly. **DO NOT:**

- disassemble components unless absolutely necessary;
- use solvents on internal brake components;
- use spent brake fluid for cleaning; (use only clean brake fluid)
- allow brake fluid to come in contact with the eyes, as this may cause eye injury;
- splash brake fluid onto painted surfaces or plastic parts, as this may cause damage;
- disconnect any hydraulic connection, as this would require the entire brake system to be disassembled, drained, cleaned, properly filled and bled after reassembly.

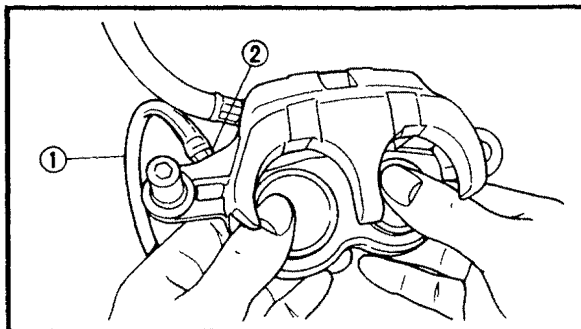
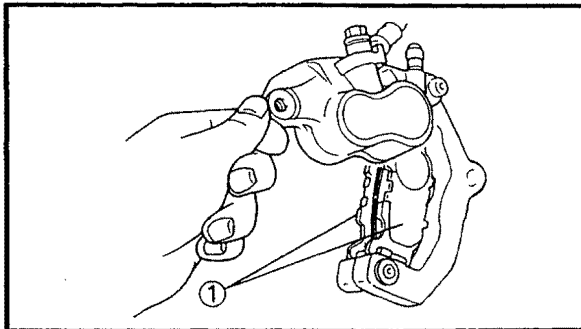
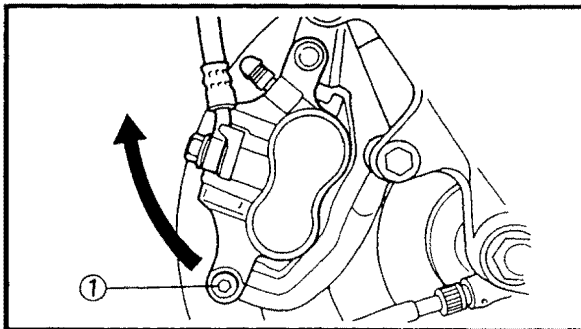

BRAKE PAD REPLACEMENT

NOTE:

It is not necessary to disassemble the brake caliper and brake hose to replace the brake pads.

1.Remove:

- Bolt (caliper support bolt) ①
Move the direction brake caliper to the arrow mark.

2.Remove:

- Brake pads ①

NOTE:

- Install new brake pad springs when the brake pads have to be replaced.
- Replace the brake pads as a set if either is found to be worn to the wear limit.

3.Install:

- Brake pads
- Brake pads spring

Installation steps:

- Connect a suitable hose ① tightly to the brake caliper bleed screw ②. Put the other end of this hose into an open container.

- Loosen the brake caliper bleed screw and using a finger push the caliper pistons into the brake caliper.
- Tighten the brake caliper bleed screw ②.

	<p>Brake caliper bleed screw: 6 Nm (0.6 m · kg, 4.3 ft · lb)</p>
---	---

- Install new brake pads and a new brake pad spring.
- Install the brake caliper ③ and retaining bolt ④.

	<p>Bolt (brake caliper): 40 Nm (4.0 m · kg, 28.9 ft · lb) Retaining bolt: 23 Nm (2.3 m · kg, 16.6 ft · lb)</p>
---	---

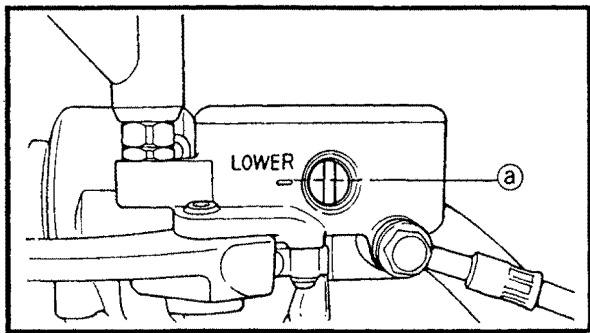
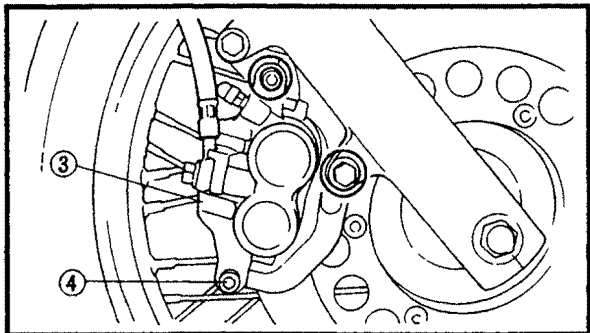

4. Inspect:
- Brake fluid level
Refer to "BRAKE FLUID INSPECTION" in CHAPTER 3.
 - ① "LOWER" level line

5. Check:
- Brake lever operation
Soft or spongy feeling → Bleed the brake system.
Refer to "AIR BLEEDING (HYDRAULIC BRAKE SYSTEM)" in CHAPTER 3.

MASTER CYLINDER

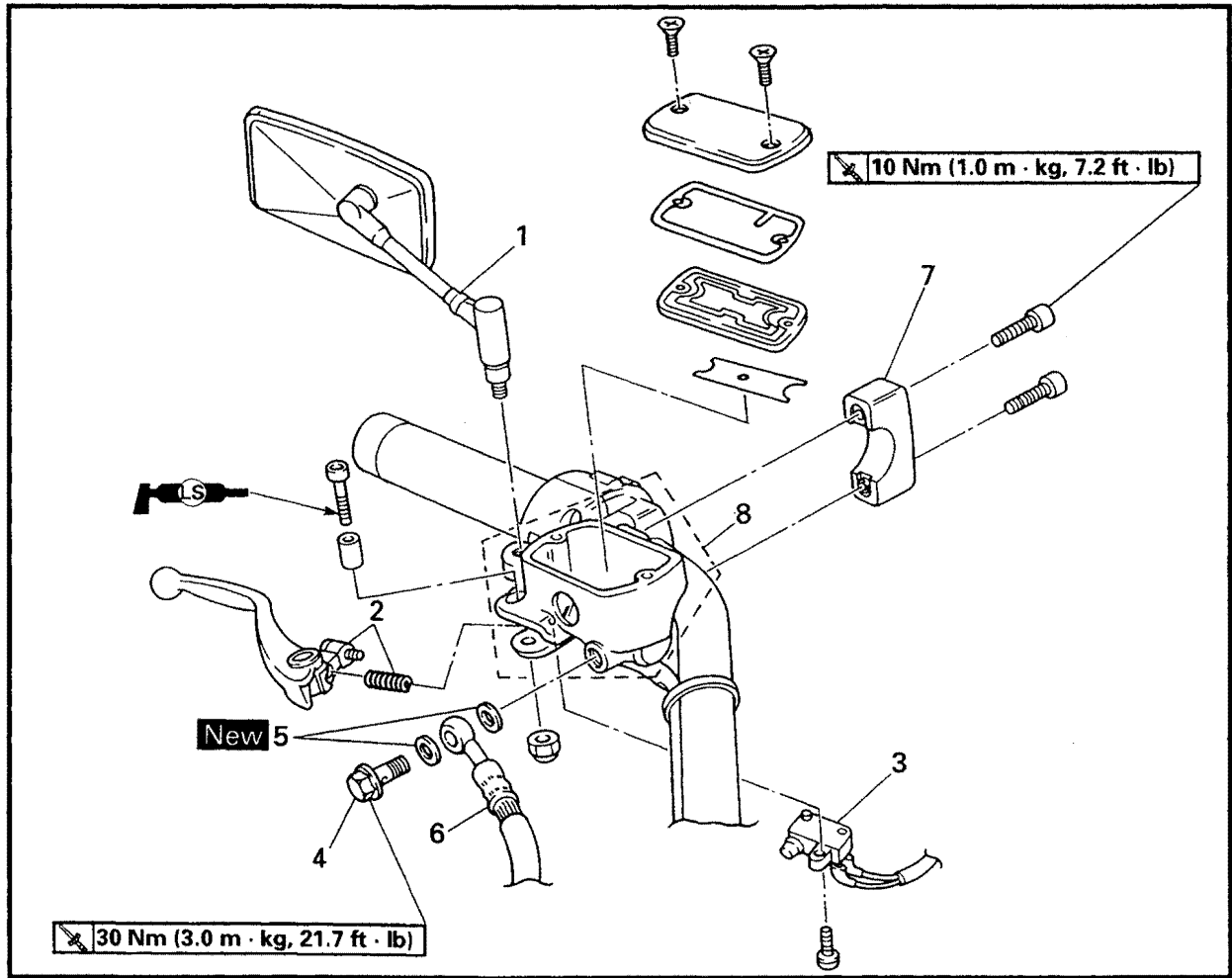

Order	Job name/Part name	Q'ty	Remarks
	Master cylinder removal		Remove the parts in the order below.
	Brake fluid		Drain
1	Rear view mirror (right)	1	
2	Brake lever/compression spring	1/1	
3	Front brake switch	1	
4	Union bolt	1	
5	Copper washers	2	Refer to "MASTER CYLINDER INSTALLATION".
6	Brake hose	1	
7	Master cylinder bracket	1	
8	Master cylinder	1	
			For installation, reverse the removal procedure.

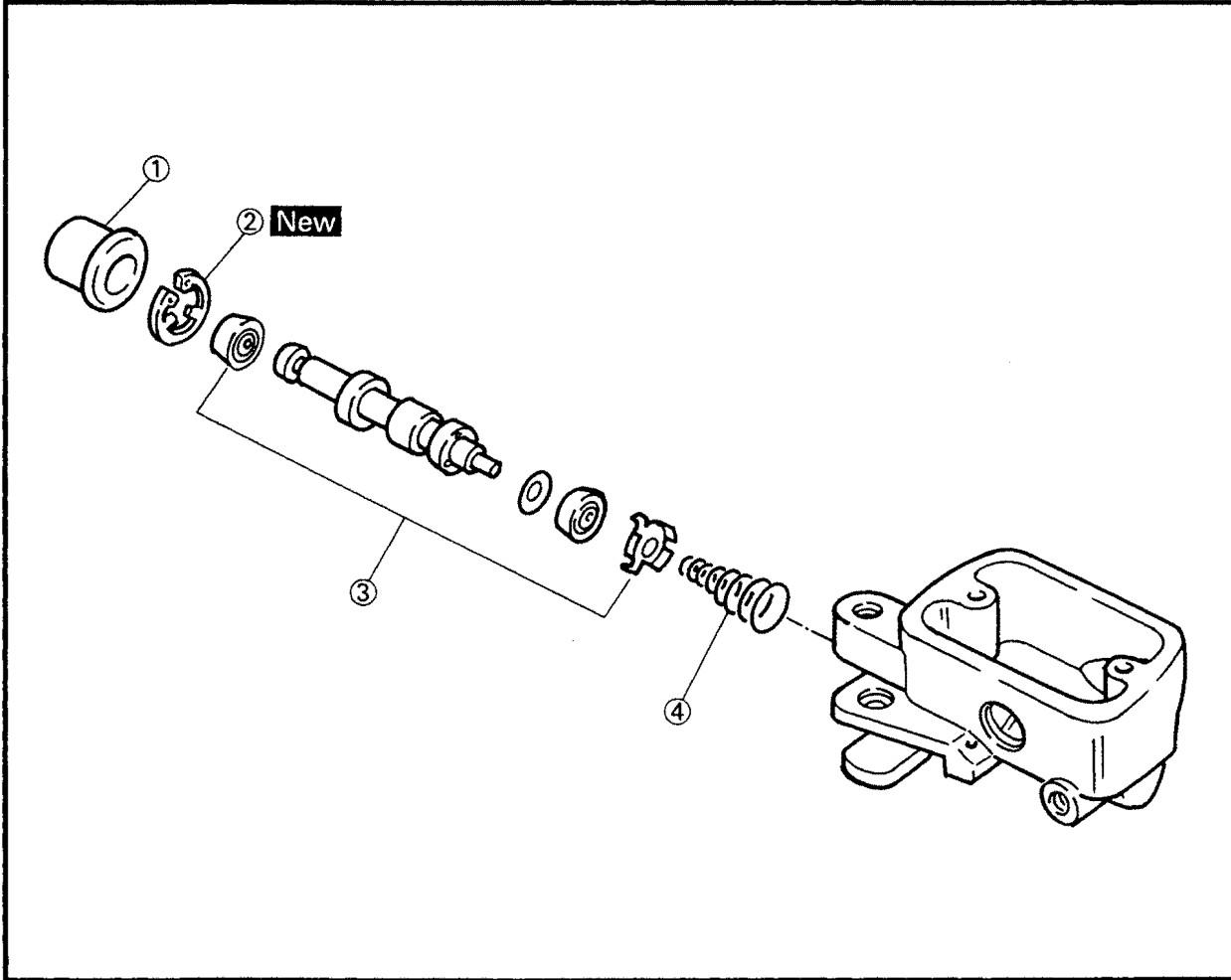

Order	Job name/Part name	Q'ty	Remarks
	Master cylinder disassembly		Disassemble the parts in the order below.
①	Dust boot	1	Refer to "MASTER CYLINDER ASSEMBLY".
②	Circlip	1	
③	Master cylinder cup kit	1	
④	Spring	1	
			For assembly, reverse the disassembly procedure.

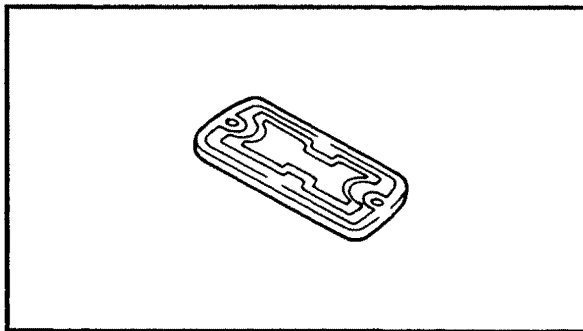
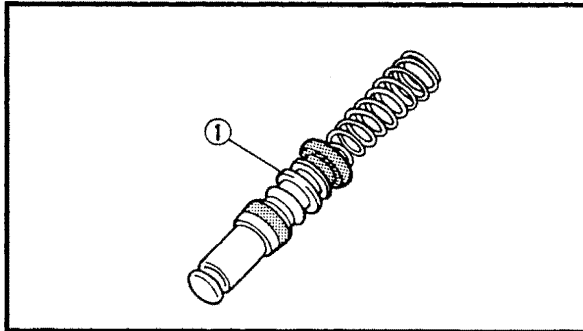
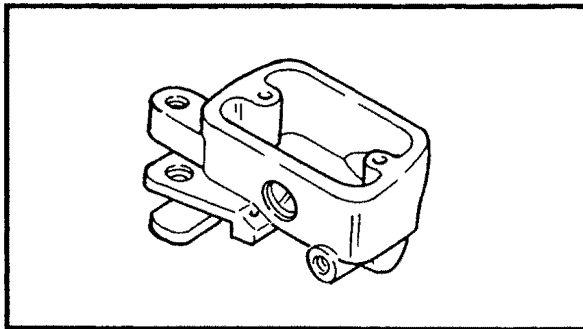

MASTER CYLINDER INSPECTION

1. Inspect:

- Master cylinder
Wear/scratches → Replace the master cylinder assembly.
- Master cylinder body
Cracks/damage → Replace.
- Oil delivery passage (master cylinder body)
Blockage → Blow out with compressed air.

2. Inspect:

- Master cylinder cup kit ①
Scratches/wear/damage → Replace as a set.

3. Inspect:

- Diaphragm
Wear/damage → Replace.

4. Inspect:

- Brake hose
Cracks/wear/damage → Replace.

EB702060

MASTER CYLINDER ASSEMBLY

⚠ WARNING

- All internal brake components should be cleaned and lubricated with new brake fluid only before installation.



Recommended brake fluid:
DOT 4

- Whenever a master cylinder is disassembled replace the piston seals and dust seals.

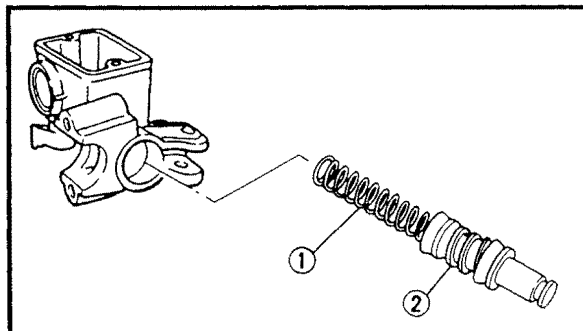

1. Install:

- Spring ①
- Master cylinder cup kit ②

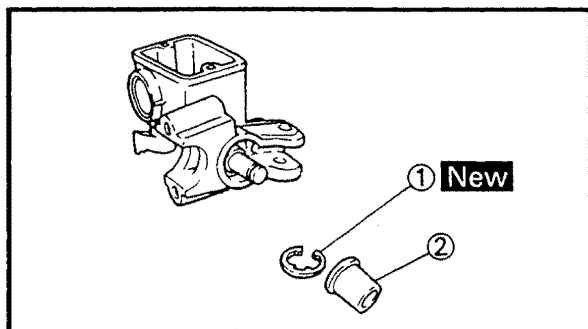

2.Install:

- Circlip ① **New**
- Dust boot ②

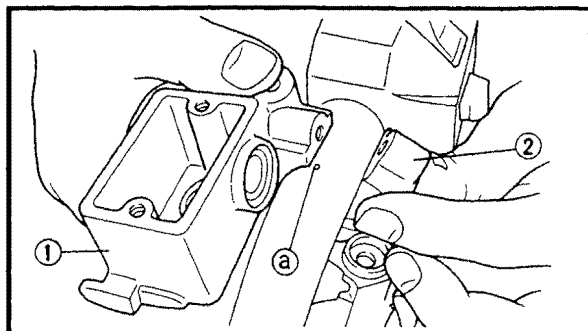

MASTER CYLINDER INSTALLATION

1.Install:

- Master cylinder ①
- Master cylinder bracket ②

 10 Nm (1.0 m · kg, 7.2 ft · lb)

CAUTION:

- Install the master cylinder holder with the "UP" mark facing upward.
- Align the end of the holder with the punch mark ① on the handlebar.
- First, tighten the upper bolt, then tighten the lower bolt.

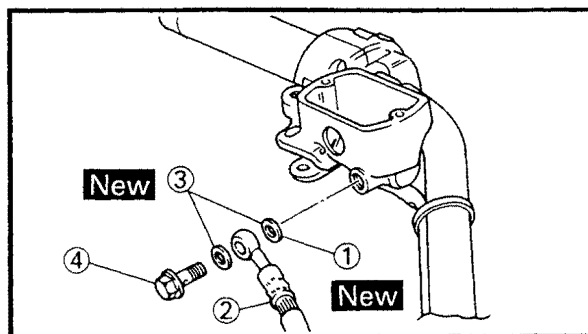

2.Install:

- Copper washers ① **New**
- Brake hose ②
- Union bolt ③

 30 Nm (3.0 m · kg, 21.7 ft · lb)

NOTE:

- Tighten the union bolt while holding the brake hose as shown.
- Turn the handlebar to the left and to the right to check that the brake hose does not touch other parts (throttle cable, wire harness, leads, etc.). Correct if necessary.

⚠ WARNING

- Proper brake hose routing is essential to insure safe motorcycle operation. Refer to "CABLE ROUTING".
- Always use new copper washers.



3.Fill:

- Reservoir tank



Recommended brake fluid:
DOT 4

CAUTION:

Brake fluid may damage painted surfaces or plastic parts. Always clean up spilled brake fluid immediately.

⚠ WARNING

- Use only the designated quality brake fluid: other brake fluids may deteriorate the rubber seals, causing leakage and poor brake performance.
- Refill with the same type of brake fluid: mixing brake fluids may result in a harmful chemical reaction and lead to poor brake performance.
- Be careful that water does not enter the master cylinder when refilling. Water will significantly lower the boiling point of the brake fluid and may result in vapor lock.

4.Air bleed:

- Brake system
Refer to "AIR BLEEDING (HYDRAULIC BRAKE SYSTEM)" in CHAPTER 3.

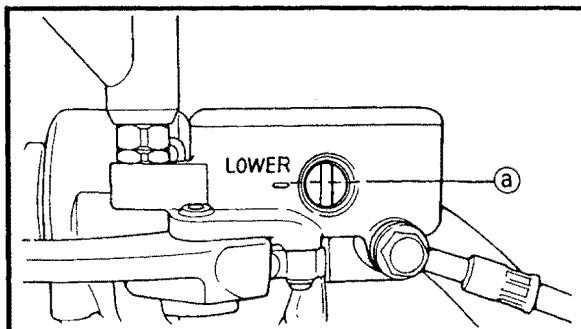

5.Inspect:

- Brake fluid level
Brake fluid level is under the "LOWER" level line → Fill up.
Refer to "BRAKE FLUID LEVEL INSPECTION" in CHAPTER 3.
- ① "LOWER" level line

FRONT BRAKE CALIPER

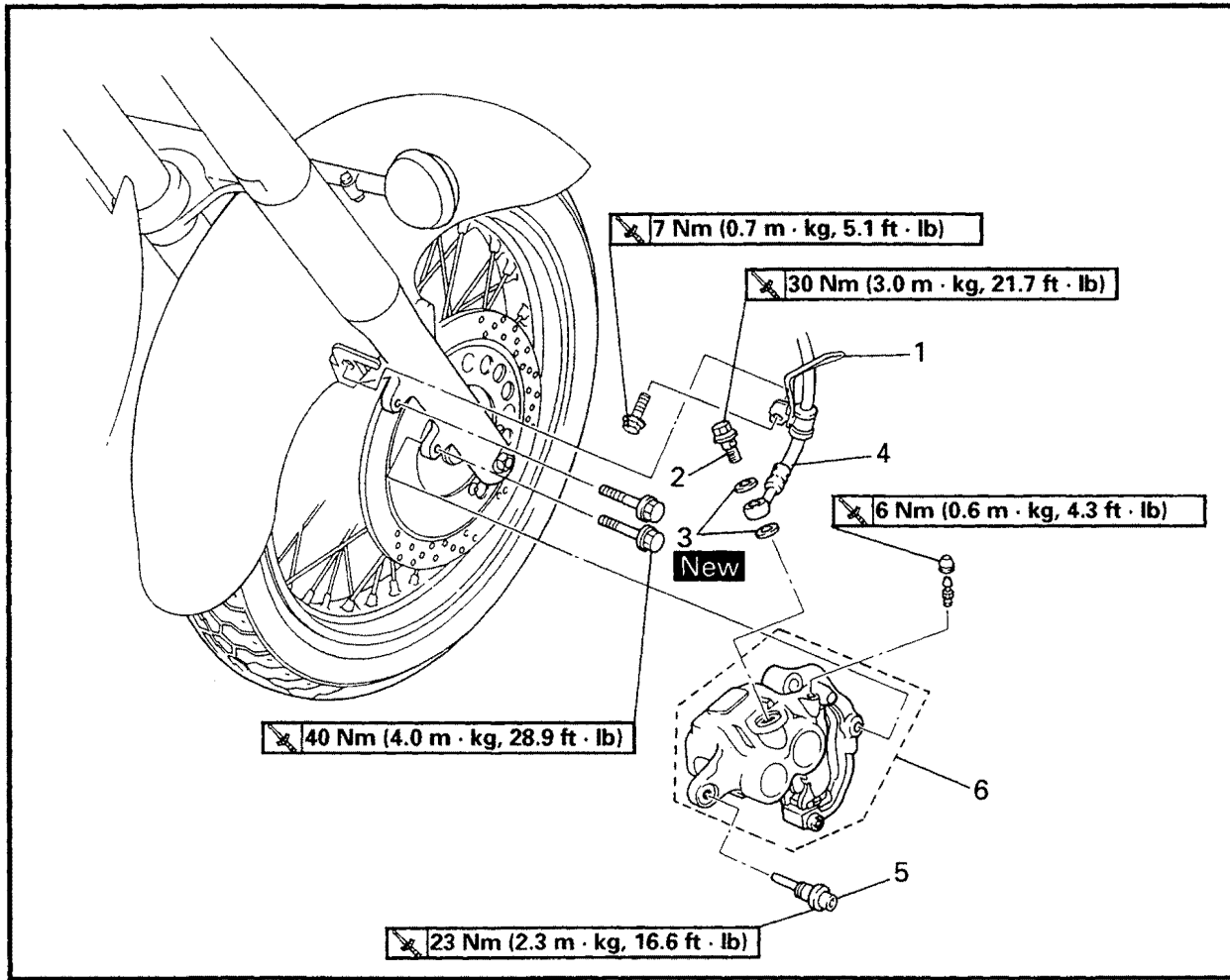

Order	Job name/Part name	Q'ty	Remarks
	Front brake caliper removal		Remove the parts in the order below.
	Brake fluid		Drain
1	Brake hose holder	1	Refer to "CALIPER INSTALLATION".
2	Union bolts	1	
3	Copper washers	2	
4	Brake hose	1	
5	Retaining bolt	1	
6	Brake caliper assembly	1	
			For installation, reverse the removal procedure.

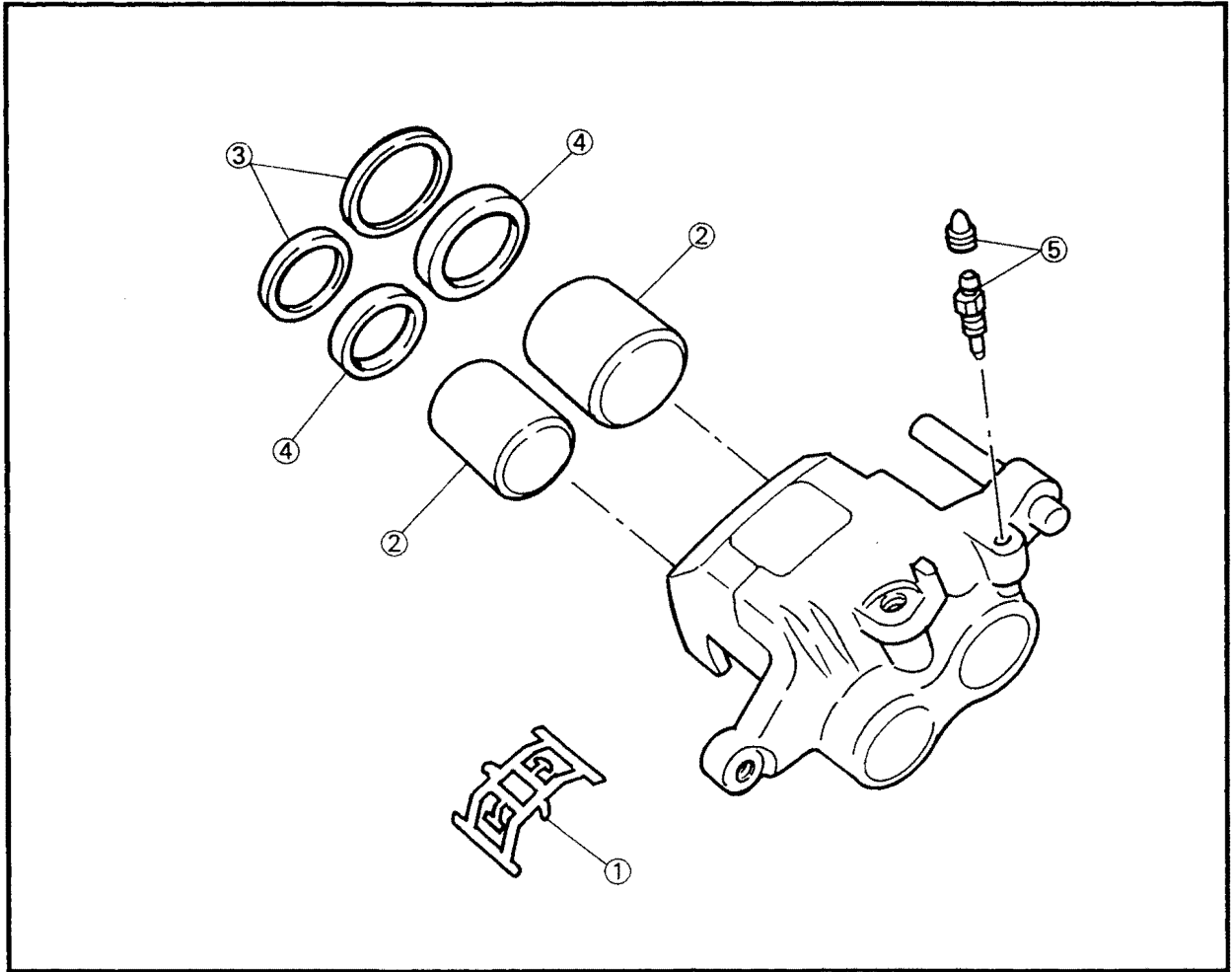

Order	Job name/Part name	Q'ty	Remarks
	Front brake caliper disassembly		Disassemble the parts in the order below.
	Brake pads		Refer to "FRONT BRAKE PADS".
①	Pad spring	1	Refer to "CALIPER DISASSEMBLY/ASSEMBLY".
②	Brake caliper pistons	2	
③	Dust seals	2	
④	Caliper piston seals	2	
⑤	Bleed screw	1	For assembly, reverse the disassembly procedure.

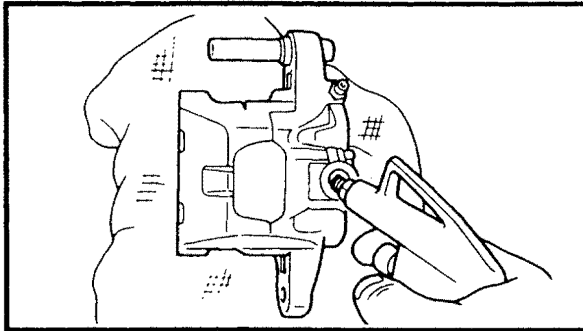
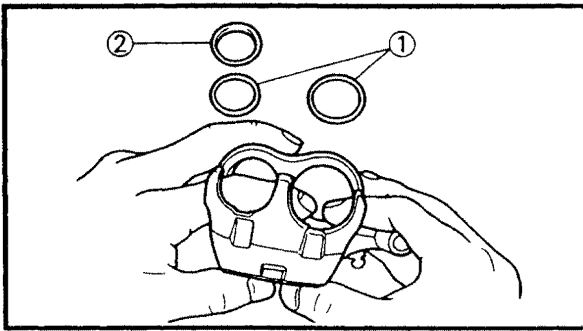

CALIPER DISASSEMBLY

1.Remove:

- Brake caliper pistons
- Dust seals ①
- Caliper piston seals ②

Removal steps:

- Blow compressed air into the hose joint opening to force out the caliper piston from the brake caliper body.

⚠ WARNING

- Never try to pry out the caliper pistons.
- Cover the caliper piston with a rag. Be careful not to get injured when the piston is expelled from the master cylinder.

- Remove the caliper piston seals.

EB702040

CALIPER INSPECTION

Recommended brake component replacement schedule:	
Brake pads	As required
Piston seals, dust seals	Every two years
Brake hoses	Every two years
Brake fluid	Replace when brakes are disassembled.

⚠ WARNING

All internal brake components should be cleaned in new brake fluid only. Do not use solvents as they will cause seals to swell and distort.

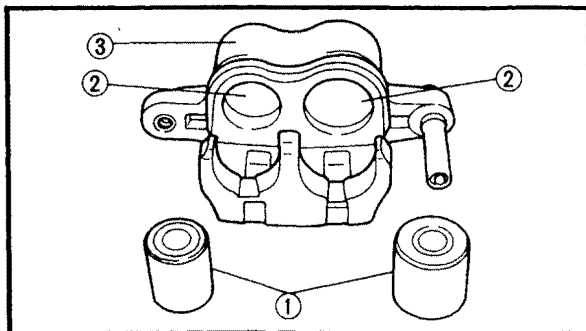

1.Inspect:

- Brake caliper piston ①
Scratches/rust/wear → Replace the brake caliper assembly.
- Brake caliper cylinder ②
Wear/scratches → Replace the brake caliper assembly.
- Brake caliper body ③
Cracks/damage → Replace.

- Oil delivery passage (brake caliper body) Blockage → Blow out with compressed air.

⚠ WARNING

Replace the caliper piston seal and dust seal whenever the brake caliper is disassembled.

CALIPER ASSEMBLY

⚠ WARNING

- All internal brake components should be cleaned and lubricated with new brake fluid only before installation.

	Recommended brake fluid: DOT 4
--	-----------------------------------

- Replace the caliper piston seals whenever a brake caliper is disassembled.

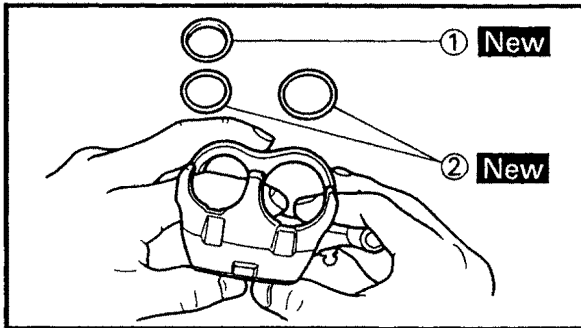

1.Install:

- Caliper piston seals ① **New**
- Dust seals ② **New**

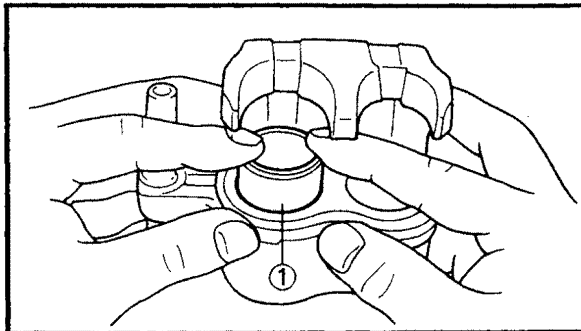

2.Install:

- Brake caliper pistons ①

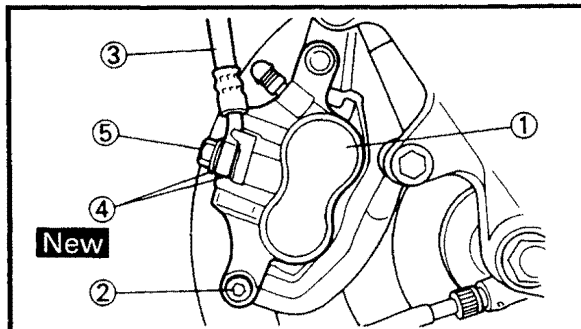

CALIPER INSTALLATION

1.Install:

- Brake caliper ①
- Retaining bolt ②

⚡ 23 Nm (2.3 m · kg, 16.6 ft · lb)

- Brake hose ③
- Copper washers ④ **New**
- Union bolt ⑤

⚡ 30 Nm (3.0 m · kg, 21.7 ft · lb)

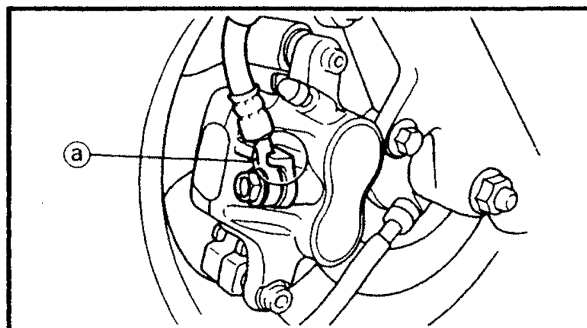
**CAUTION:**

When installing the brake hose on the brake caliper, make sure that the brake pipe touches the projection ① on the brake caliper.

⚠ WARNING

Proper brake hose routing is essential to insure safe motorcycle operation. Refer to "CABLE ROUTING".

2.Fill:

- Brake reservoir



Recommended brake fluid:
DOT 4

CAUTION:

Brake fluid may damage painted surfaces or plastic parts. Always clean up spilled brake fluid immediately.

⚠ WARNING

- Use only the designated quality brake fluid: other brake fluids may deteriorate the rubber seals, causing leakage and poor brake performance.
- Refill with the same type of brake fluid: mixing brake fluids may result in a harmful chemical reaction and lead to poor brake performance.
- Be careful that water does not enter the master cylinder when refilling. Water will significantly lower the boiling point of the brake fluid and may result in vapor lock.

3.Air bleed

- Brake system
Refer to "AIR BLEEDING" in CHAPTER 3.

4.Inspect:

- Brake fluid level
Brake fluid level is under the "LOWER" level line → Fill up.
Refer to "BRAKE FLUID INSPECTION" in CHAPTER 3.

① "LOWER" level line

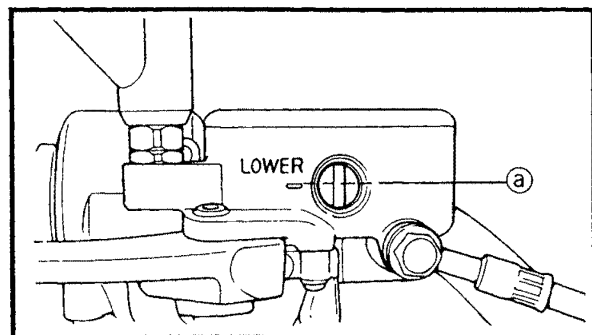

REAR WHEEL AND REAR BRAKE
MUFFLER AND REAR BRAKE ROD

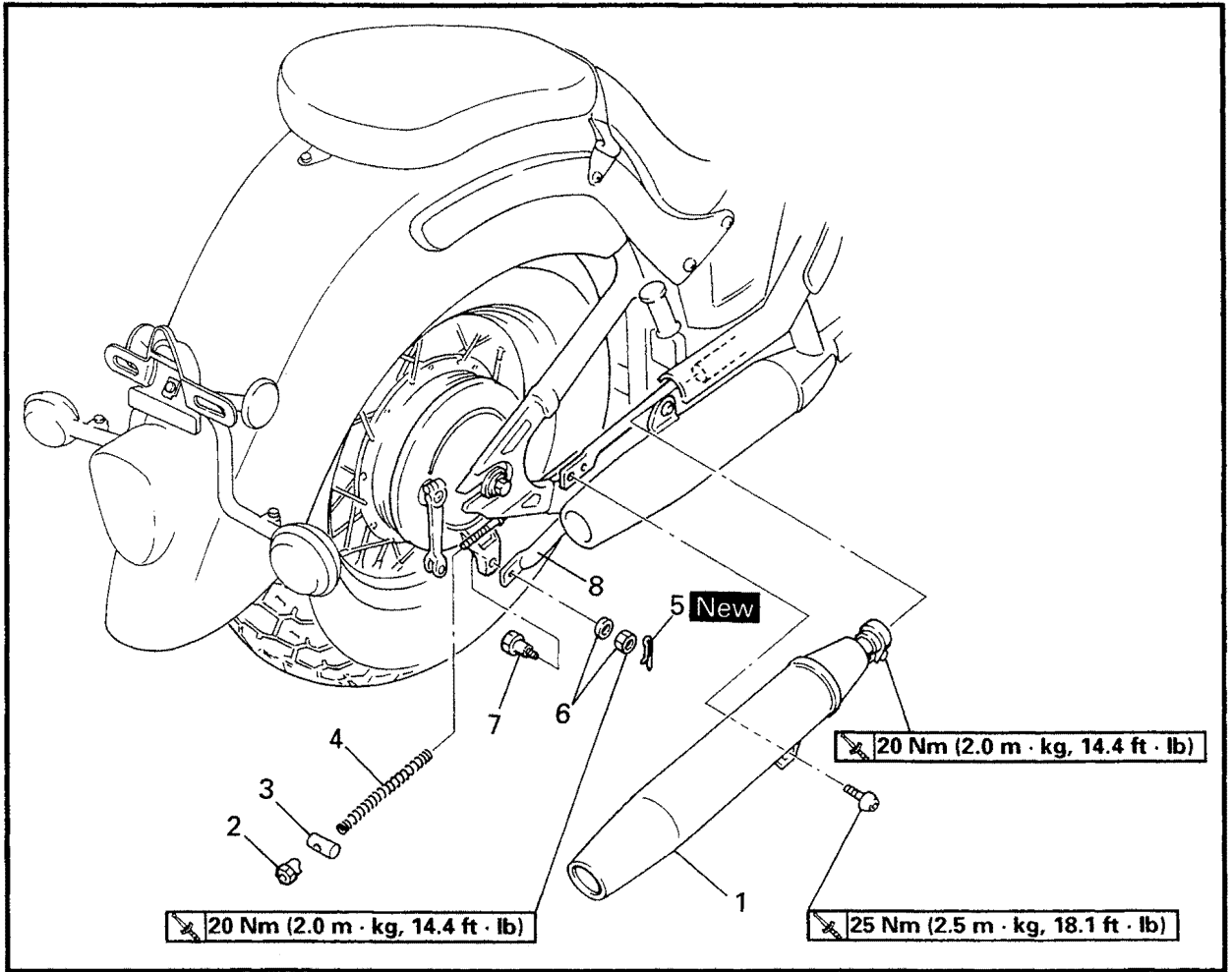

Order	Job name/Part name	Q'ty	Remarks
	Muffler and rear brake rod removal		Remove the parts in the order below.
1	Muffler	1	
2	Adjuster	1	
3	Pin	1	
4	Compression spring	1	
5	Cotter pin	1	
6	Nut/plate washer	1/1	
7	Bolt	1	
8	Tension bar	1	
			For installation, reverse the removal procedure.

REAR WHEEL

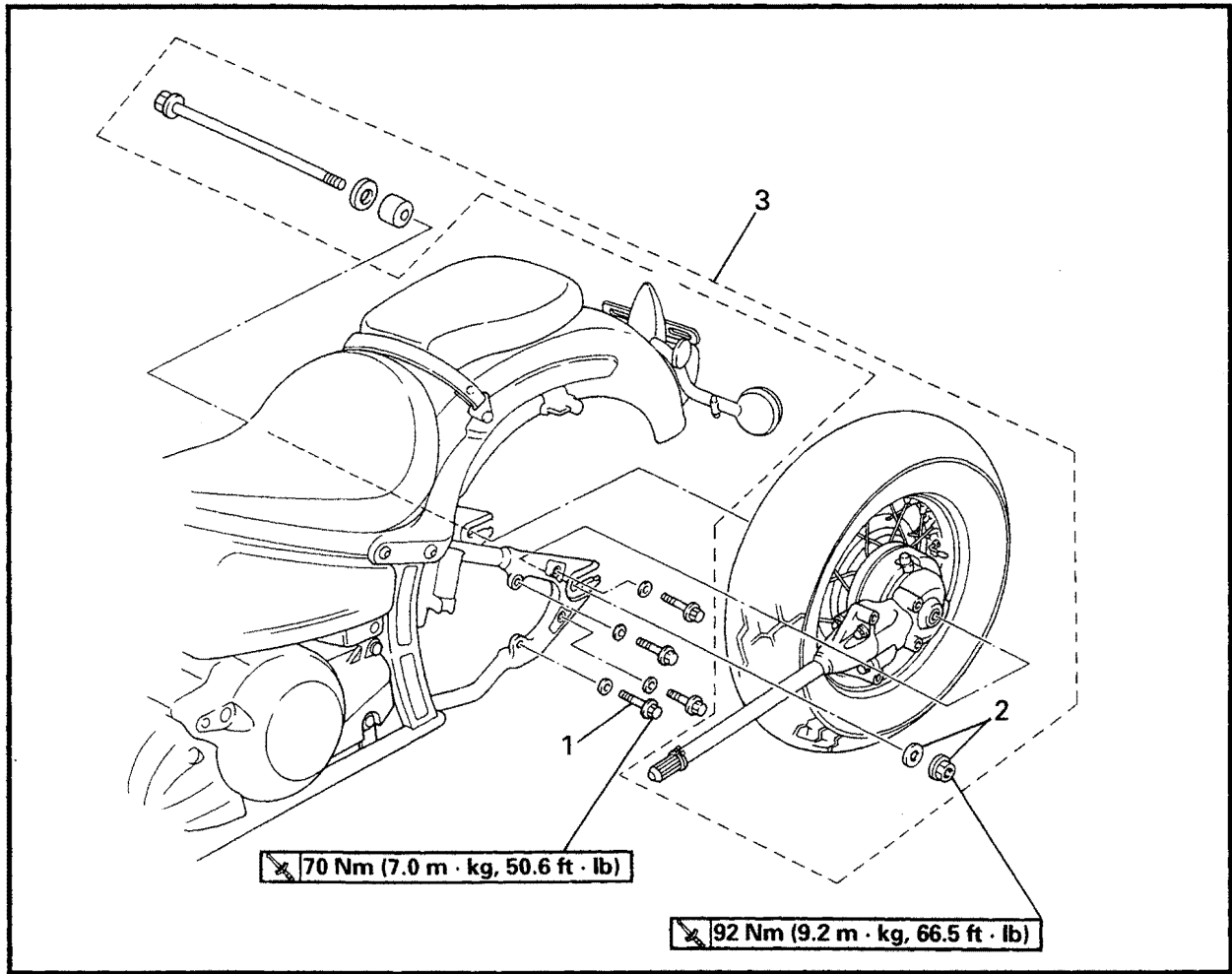

Order	Job name/Part name	Q'ty	Remarks
	Rear wheel removal		Remove the parts in the order below. Stand the motorcycle on a level surface.
	Final gear oil		⚠ WARNING Securely support the motorcycle so there is no danger of it falling over.
			Drain Refer to "FINAL GEAR OIL REPLACEMENT" in CHAPTER 3.
1	Bolts	4	Refer to "REAR WHEEL REMOVAL/INSTALLATION".
2	Rear axle nut/washer	1/1	
3	Rear wheel assembly	1	
			For installation, reverse the removal procedure.

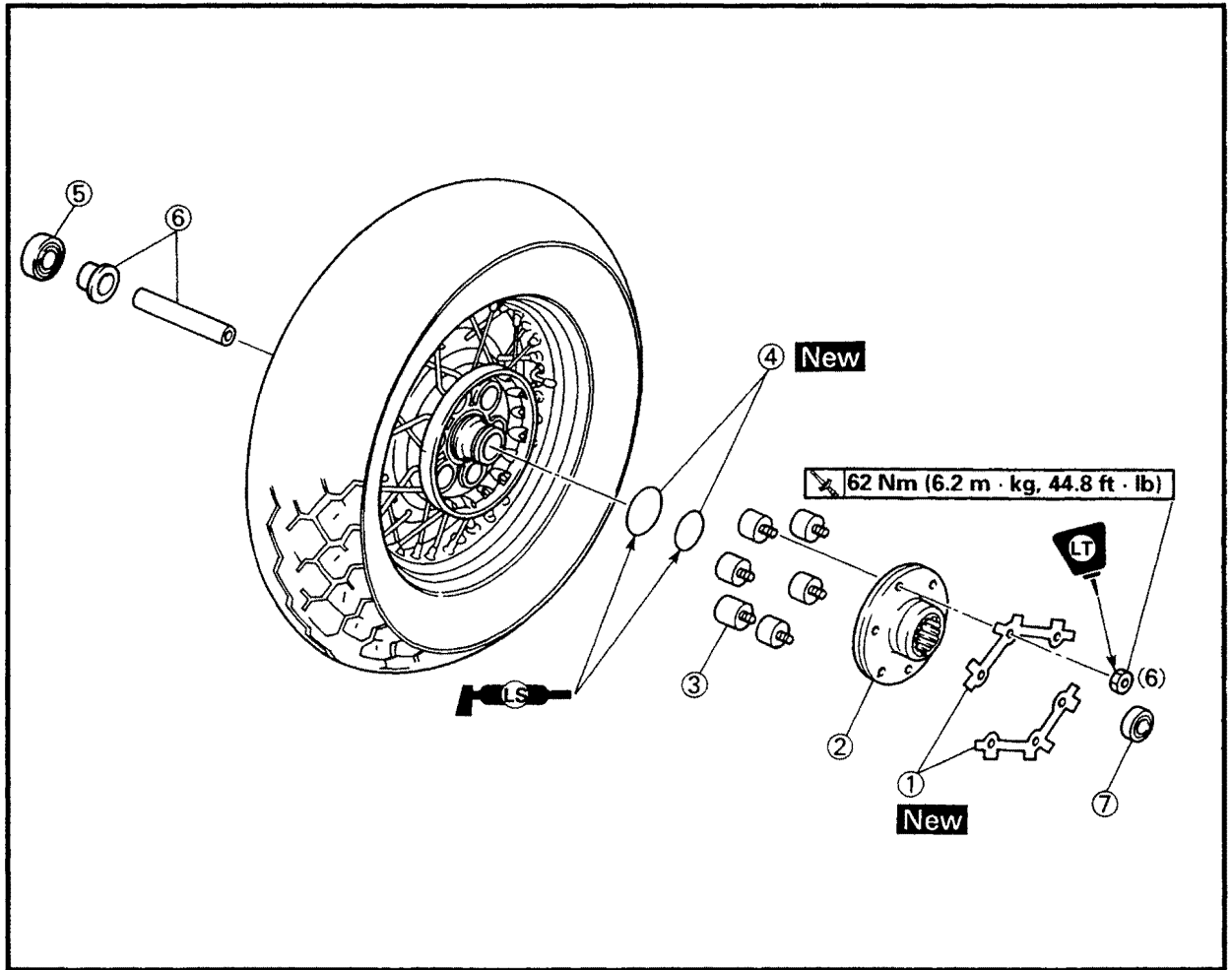

Order	Job name/Part name	Q'ty	Remarks
	Rear wheel disassembly		Disassemble the parts in the order below.
①	Lock washers	2	Refer to "REAR WHEEL DISASSEMBLY/ASSEMBLY". For assembly, reverse the disassembly procedure.
②	Clutch hub	1	
③	Dampers	6	
④	O-rings	2	
⑤	Bearing	1	
⑥	Spacer/collar	1/1	
⑦	Bearing	1	

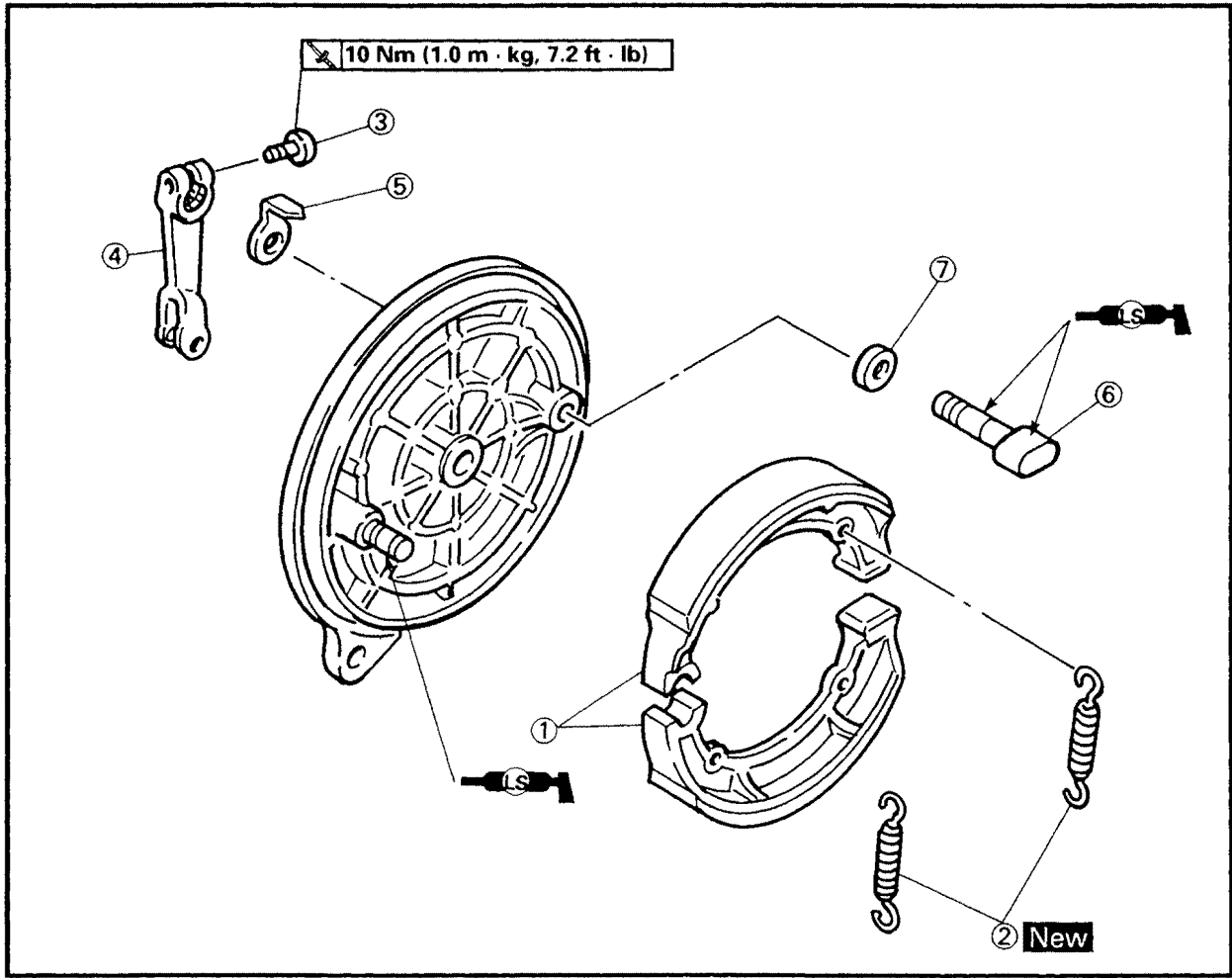

Order	Job name/Part name	Q'ty	Remarks
	Rear brake disassembly		Disassemble the parts in the order below.
①	Brake shoes	2	Refer to "REAR BRAKE ASSEMBLY".
②	Tension springs	2	
③	Bolt	1	
④	Camshaft lever	1	
⑤	Wear indicator	1	
⑥	Camshaft	1	
⑦	Washer	1	
			For assembly, reverse the disassembly procedure.

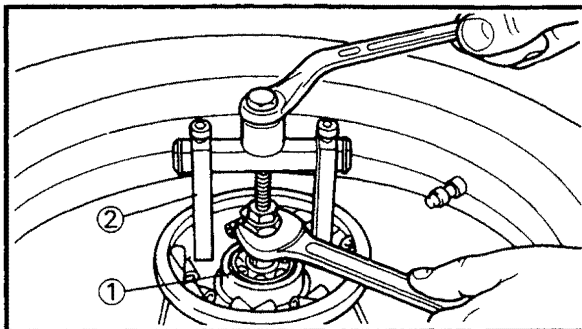
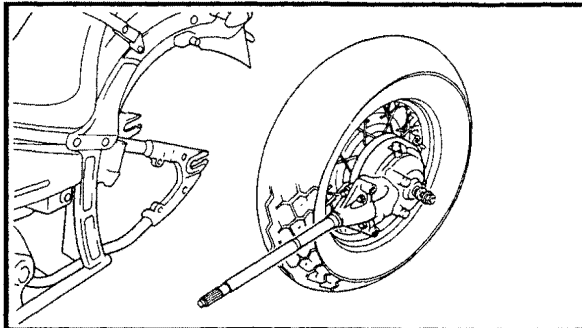
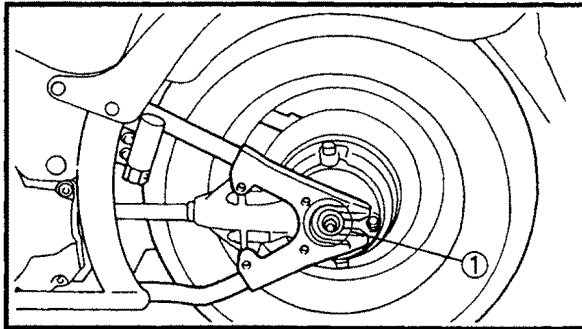
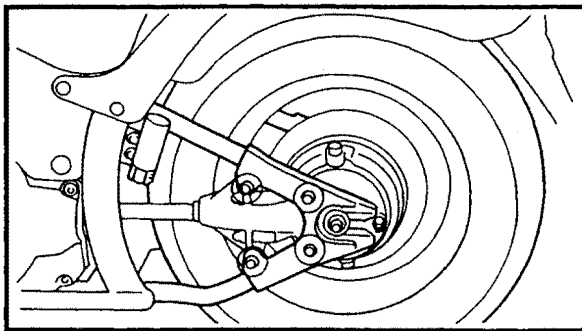

REAR WHEEL REMOVAL

1. Stand the motorcycle on a level surface.

⚠ WARNING

Securely support the motorcycle so there is no danger of it falling over.

2. Remove:

- Bolts (final gear case)

3. Loosen:

- Rear axle nut ①

4. Remove:

- Rear wheel assembly

NOTE:

Remove the rear wheel assembly, rear wheel axle and drive shaft by pulling back on the rear wheel assembly.

REAR WHEEL DISASSEMBLY

1. Remove:

- Bearings ①
Remove the bearings using a standard bearing puller ②.

REAR WHEEL INSPECTION

1. Inspect:

- Rear wheel axle
Refer to "FRONT WHEEL".
- Rear tire
Refer to "TIRE INSPECTION" in CHAPTER 3.
- Rear wheel
Refer to "WHEEL INSPECTION" in CHAPTER 3.

- 2. Check:
 - Spokes
Refer to "FRONT WHEEL".
- 3. Tighten:
 - Loose spokes
Refer to "FRONT WHEEL".
- 4. Measure:
 - Rear wheel runout
Refer to "FRONT WHEEL".
- 5. Inspect:
 - Rear wheel bearings
Refer to "FRONT WHEEL".

REAR BRAKE INSPECTION

- 1. Inspect:
 - Brake lining surface
 - Glazed areas → Polish.
Use coarse sandpaper.

NOTE: _____
Wipe the polished areas with a cloth.

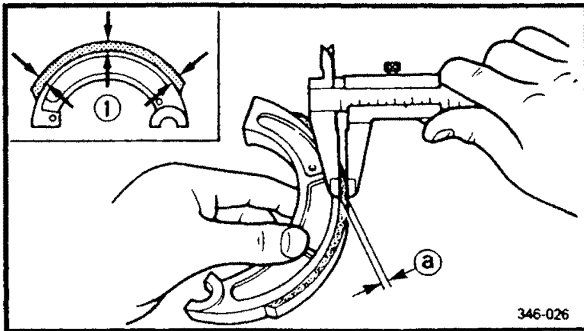

- 2. Measure:
 - Brake lining thickness (a)
Out of specification → Replace.
 - ① Measuring points

NOTE: _____
Replace the brake shoes as a set if either is found to be worn to the wear limit.

	Brake lining thickness:
	4.0 mm (0.16 in)
	Wear limit:
	2.0 mm (0.08 in)

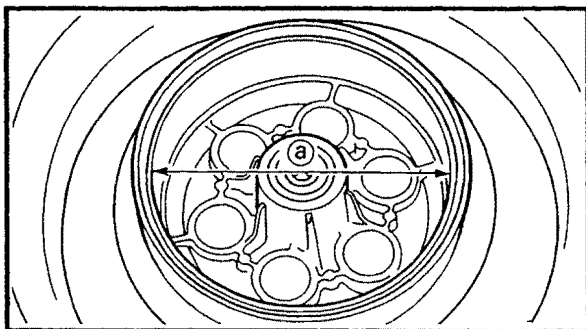

3.Measure:

- Brake drum inside diameter (a)
Out of specification → Replace the wheel.

	Brake drum inside diameter: 200 mm (7.87 in)
	Wear limit: 201 mm (7.91 in)

4.Inspect:

- Brake drum inner surface
Oil/scratches → Repair.

Oil	Use a rag soaked in lacquer thinner or solvent.
Scratches	Use an emery cloth (polish lightly and evenly)

5.Inspect:

- Camshaft face
Wear → Replace.

REAR WHEEL ASSEMBLY

1.Install:

- Spacer
- Collar
- Bearings

Installation steps:

- Install the new bearings by reversing the removal steps.

NOTE:

Use a socket ① that matches the diameter of the outer bearing race and the oil seal.

CAUTION:

Do not contact the bearing center race ② or balls ③. Contact should be made only with the outer race ④.

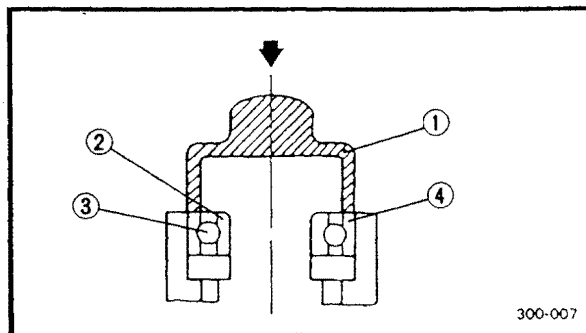

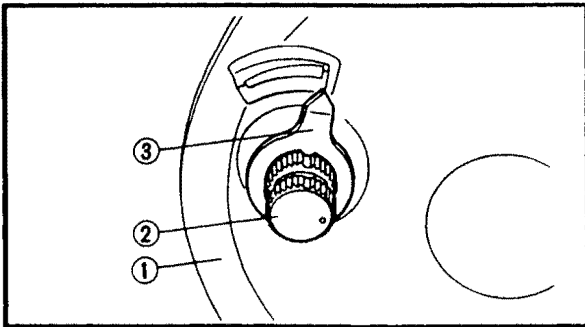

REAR BRAKE ASSEMBLY

1.Install:

- Brake shoe plate ①
- Camshaft ②
- Wear indicator ③
- Camshaft lever ④

 10 Nm (1.0 m · kg, 7.2 ft · lb)

NOTE: _____

Apply lithium soap base grease onto the camshaft and pin.

WARNING

After installing the spring and brake shoes, take care not to damage the spring.

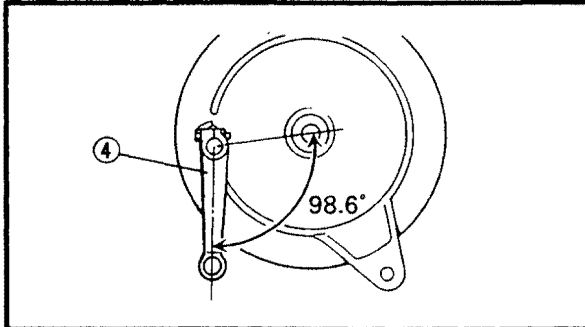

REAR WHEEL INSTALLATION

1.Install

- Rear wheel assembly

NOTE: _____

Make sure that the splines of the clutch hub fit correctly into the final gear case.

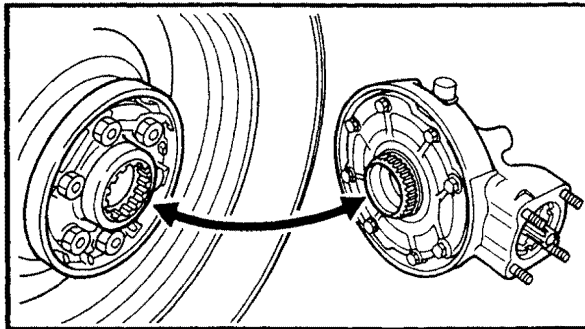

2.Install:

- Rear wheel axle
- Washer
- Rear wheel axle nut

 92 Nm (9.2 m · kg, 66.5 ft · lb)

- Bolt

 90 Nm (9.0 m · kg, 65.1 ft · lb)

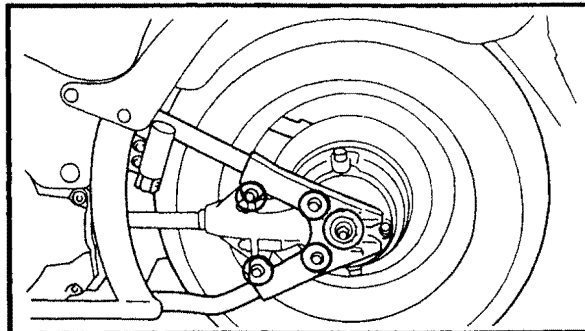

3.Adjust:

- Brake pedal free play
Refer to "REAR BRAKE ADJUSTMENT" in CHAPTER 3.



EB701040

**REAR WHEEL STATIC BALANCE
ADJUSTMENT**

NOTE: _____

- After replacing the tire and/or wheel, the static wheel balance should be adjusted.
- Adjust the static wheel balance with the rear brake disc and hub installed.

1.Adjust:

- Rear wheel static balance
Refer to "FRONT WHEEL".

FRONT FORK

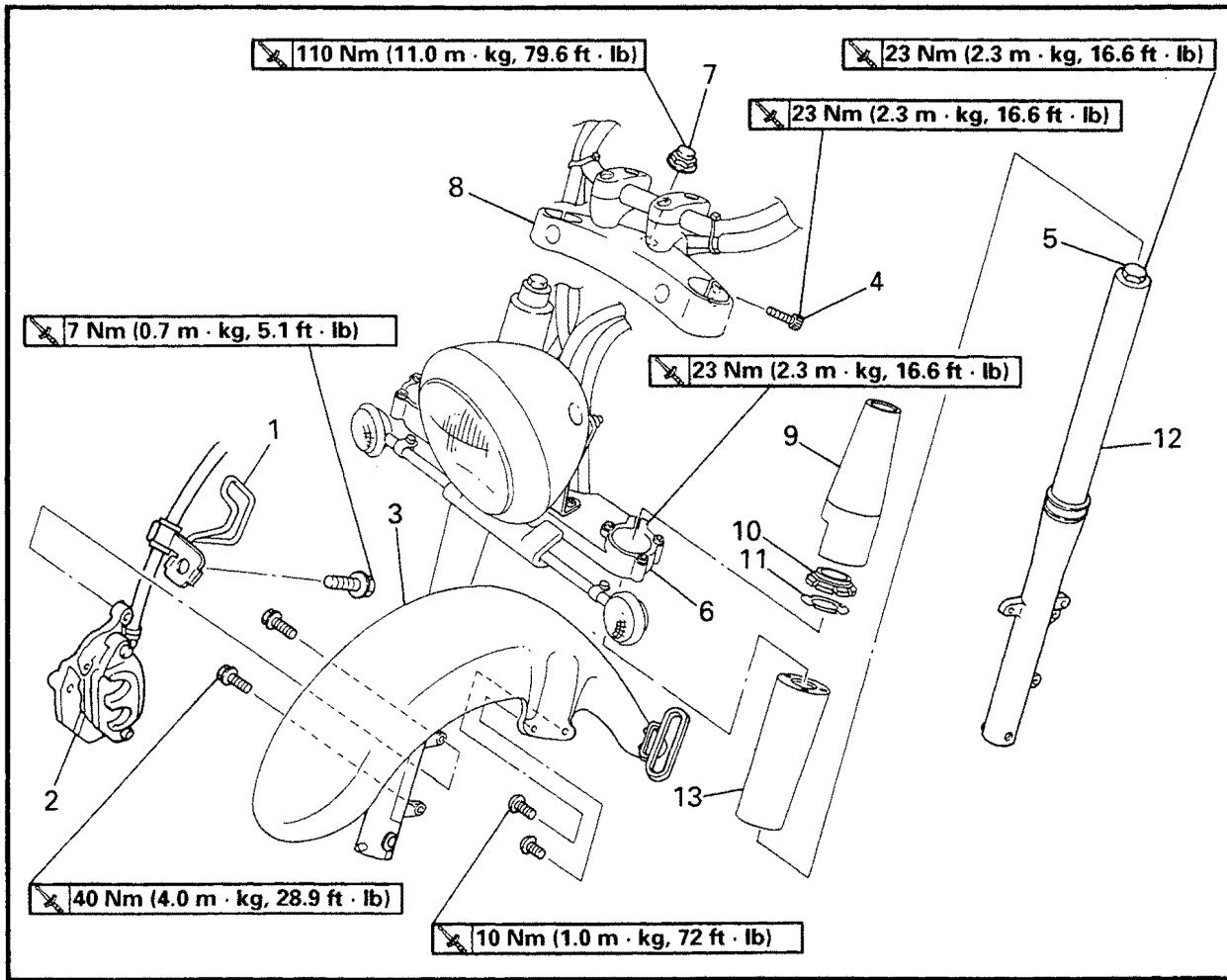

Order	Job name/Part name	Q'ty	Remarks
	Front fork removal		Remove the parts in the order below. Refer to "FRONT WHEEL".
	Front wheel		
1	Brake hose holder	1	
2	Brake caliper assembly	1	
3	Front fender	1	
4	Upper bracket bolts	2	Loosen Refer to "FRONT FORK INSTALLA- TION".
5	Cap bolts	2	
6	Lower bracket bolts	2	
7	Steering stem nut	1	
8	Upper bracket with handle	1	

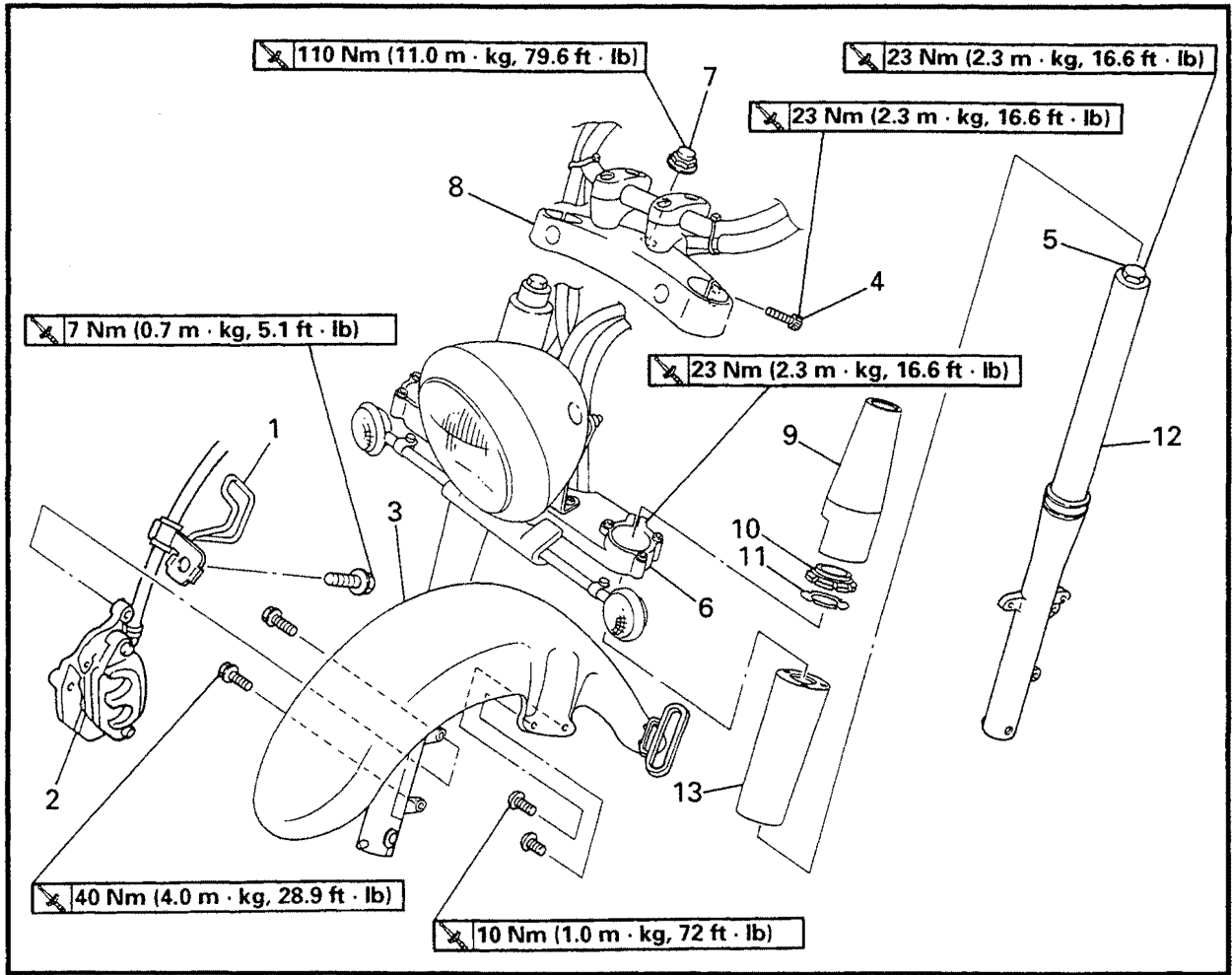

Order	Job name/Part name	Q'ty	Remarks
9	Upper fork covers	2	For installation, reverse the removal procedure.
10	Upper fork cover spacers	2	
11	Upper fork cover washers	2	
12	Front forks	2	
13	Lower fork covers	2	

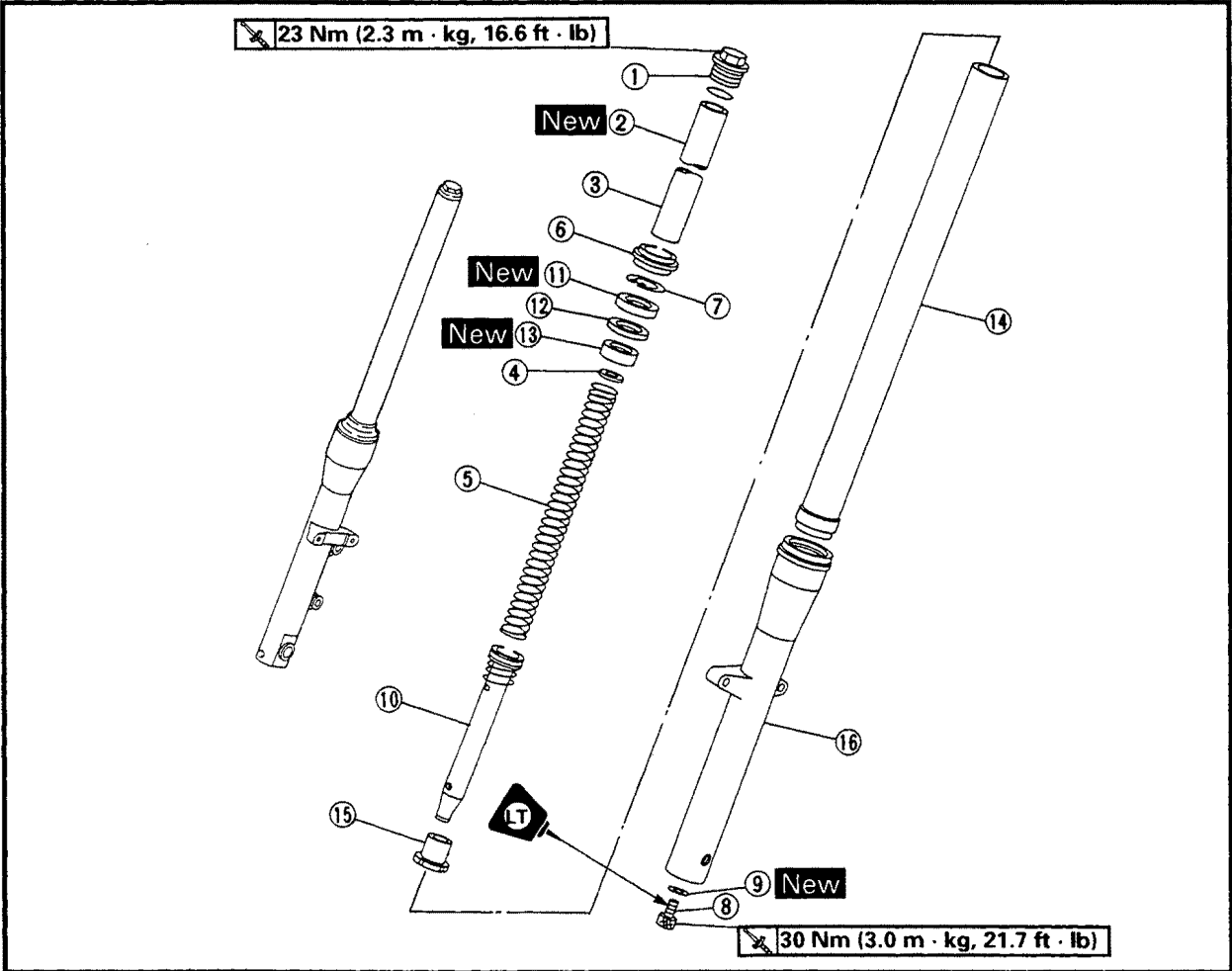

Order	Job name/Part name	Q'ty	Remarks	
	Front fork disassembly		Disassemble the parts in the order below.	
①	Cap bolt	1	Refer to "FRONT FORK ASSEMBLY".	
②	O-ring	1		
③	Spacer collar	1		
④	Spring seat	1		
⑤	Fork spring	1		
⑥	Dust seal	1		
⑦	Retaining clip	1		
⑧	Damper rod bolt	1		Refer to "FRONT FORK DISASSEMBLY/ASSEMBLY".
⑨	Gasket	1		
⑩	Damper rod/rebound spring	1/1		
⑪	Oil seal	1		

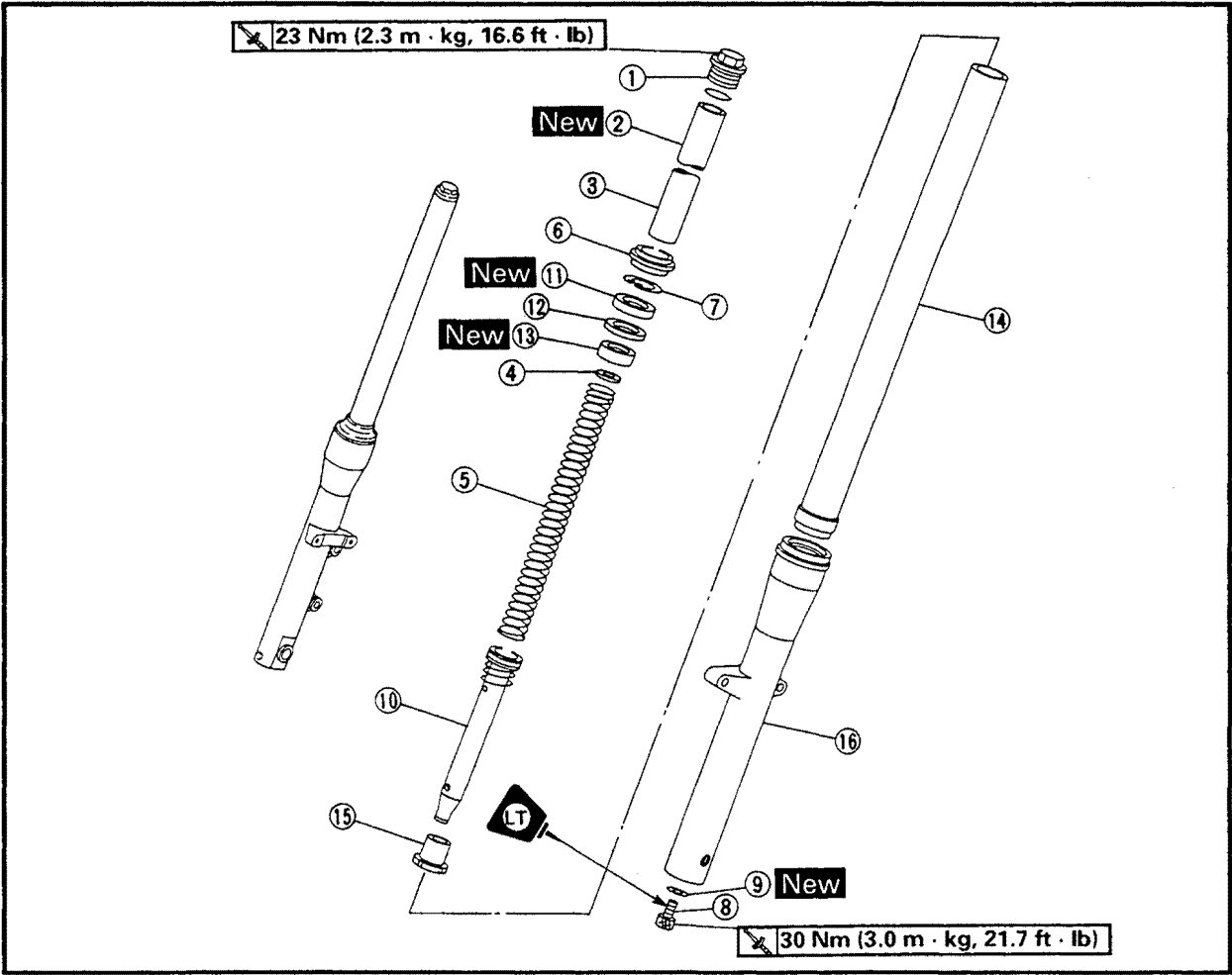

Order	Job name/Part name	Q'ty	Remarks
⑫	Seal spacer	1	Refer to "FRONT FORK ASSEMBLY".
⑬	Slide metal	1	
⑭	Inner tube/piston metal	1/1	
⑮	Oil lock piece	1	
⑯	Outer tube	1	
			For assembly, reverse the disassembly procedure.

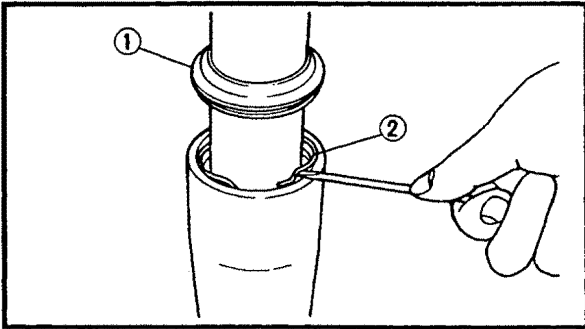

FRONT FORK DISASSEMBLY

1.Remove:

- Dust seal ①
- Retaining clip ②
(use a slotted-head screwdriver)

CAUTION:

Take care not to scratch the inner tube.

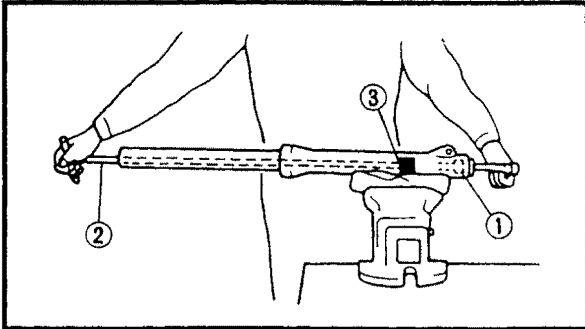

2.Remove:

- Damper rod bolt ①

NOTE:

Loosen the damper rod while holding the damper rod with the T-handle ② and the damper rod holder ③.



T-Handle:
YM-01326, 90890-01326
Damper rod holder:
YM-01388, 90890-01388

3.Remove:

- Damper rod
- Rebound spring

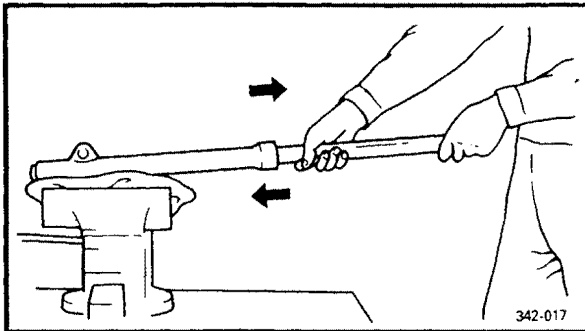

4.Remove

- Inner tube

Removal steps:

- Hold the fork leg horizontally.
- Securely clamp the caliper mounting boss of the outer tube in a vise with soft jaws.
- Separate the inner tube from the outer tube by pulling forcefully but carefully on the inner tube.

CAUTION:

- Excessive force will damage the oil seal and/or the slide metal. A damaged oil seal and metal must be replaced.
- Avoid bottoming the inner tube into the outer tube during the above procedure, as the oil lock piece will be damaged.

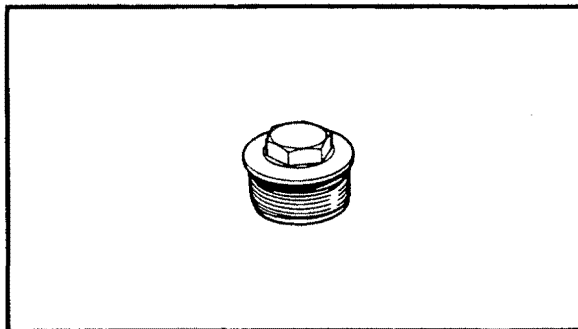
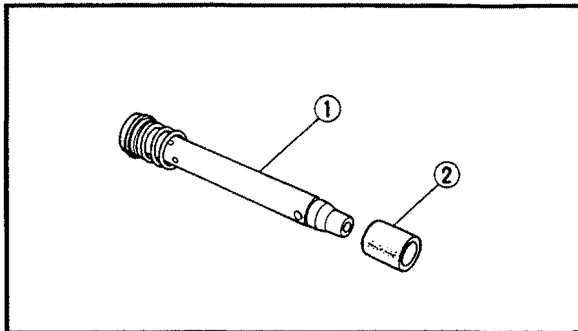
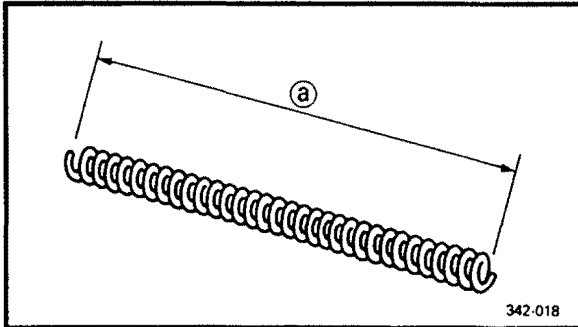
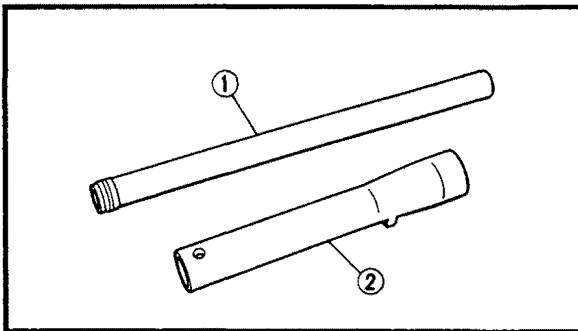

EB703030

FRONT FORK INSPECTION

1. Inspect:

- Inner tube ①
 - Outer tube ②
- Scratches/bends/damage → Replace.

⚠ WARNING

Do not attempt to straighten a bent inner tube as this may dangerously weaken the tube.

2. Measure:

- Fork spring length ③
- Over the specified limit → Replace.



**Fork spring free length (limit):
332.5 mm (13.1 in)**

3. Inspect:

- Damper rod ①
- Wear/damage → Replace.
Contamination → Blow out all of the oil passages with compressed air.
- Oil lock piece ②
- Damage → Replace.

4. Inspect:

- O-ring (cap bolt)
- Wear/damage → Replace.

FRONT FORK ASSEMBLY**NOTE:**

- When reassembling the front fork, replace the following parts.
 - *Piston metal
 - *Slide metal
 - *Oil seal
 - *Dust seal
- Before reassembly make sure that all the components are clean.

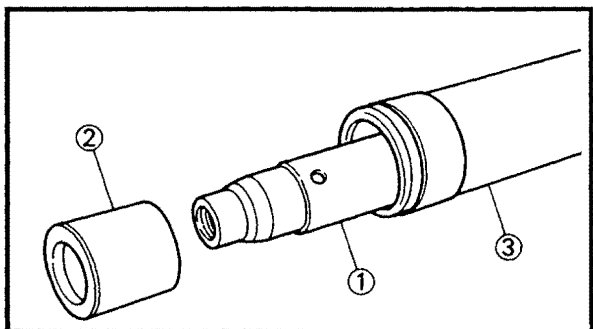

1. Install:
- Damper rod ①
 - Rebound spring
 - Oil lock piece ②
 - Inner tube ③

CAUTION:

Allow the damper rod to slide slowly down the inner tube until it protrudes from the bottom, being careful not to damage the inner tube.

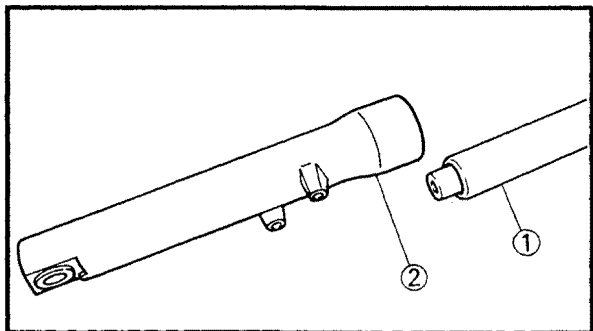

2. Lubricate:
- Inner tube (outer surface)



Recommended lubricant:
Yamaha fork oil 10WT or equivalent

3. Install:
- Inner tube ①
(to outer tube ②)

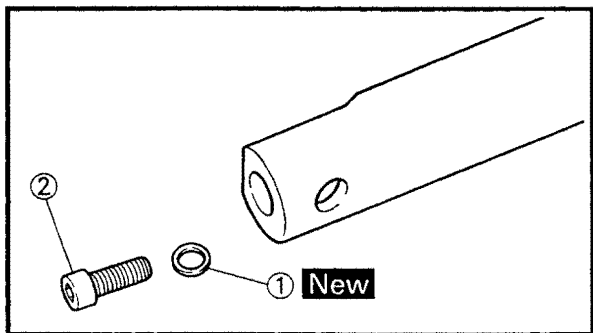

4. Install:
- Gasket ① **New**
 - Damper rod bolt ②

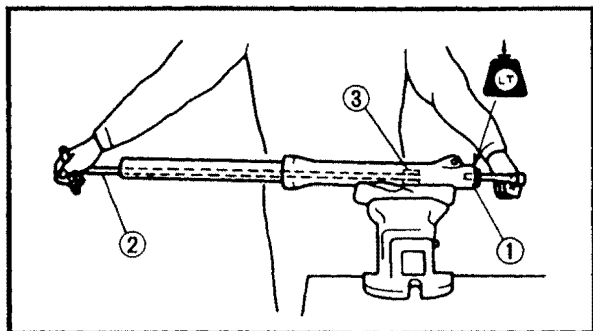

5. Tighten:
- Damper rod bolt ①

30 Nm (3.0 m · kg, 21.7 ft · lb)

NOTE:

Apply LOCTITE® to the threads of the damper rod holder. Tighten the damper rod bolt while holding the damper rod with a T-handle ② and a damper rod holder ③.



T-handle:
YM-01326, 90890-01326
Damper rod holder:
YM-01388, 90890-01388

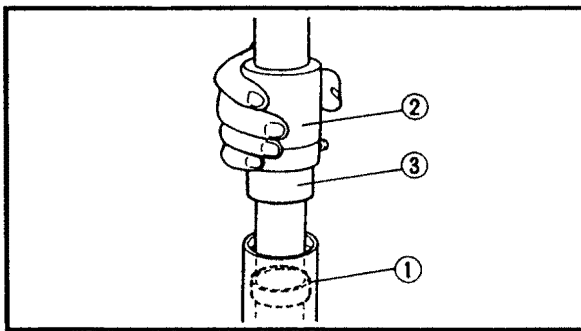

6.Install:

- Slide metal ① **New**
- Seal spacer

Use the fork seal driver weight ② and the adapter ③.

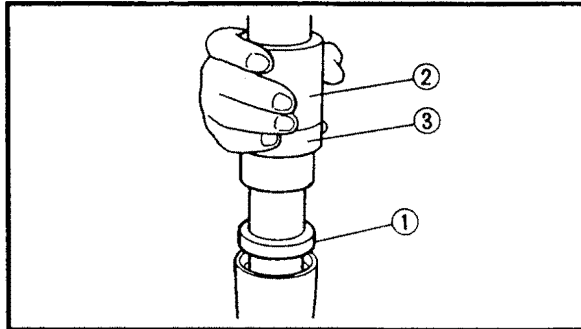

7.Install:

- Oil seal ① **New**

Use the fork seal driver weight ② and the adapter ③.



Fork seal driver weight:
YM-01326, 90890-01367
Adapter:
YM-01388, 90890-01381

NOTE:

Before installing the oil seal, apply lithium soap base grease onto the oil seal lips.

CAUTION:

Make sure that the numbered side of the oil seal faces up.

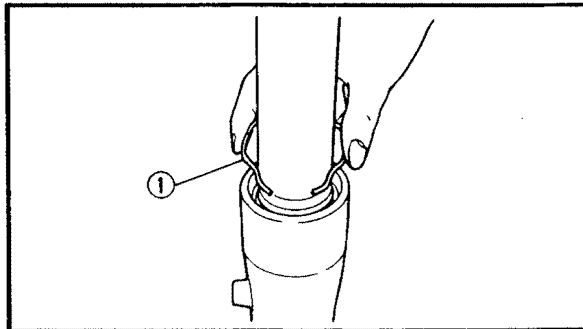

8.Install:

- Retaining clip ①

NOTE:

Adjust the retaining clip so that it fits into the outer tube groove.

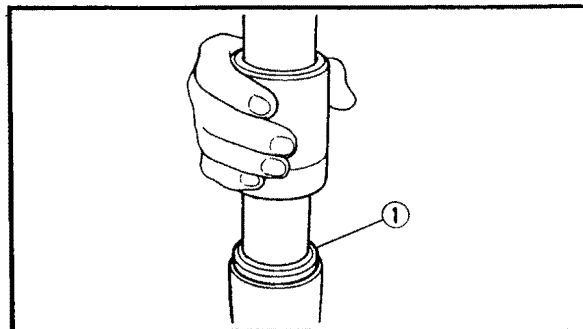

9.Install:

- Dust seal ①

Use the fork seal driver weight.



Fork seal driver weight:
YM-33963, 90890-01367

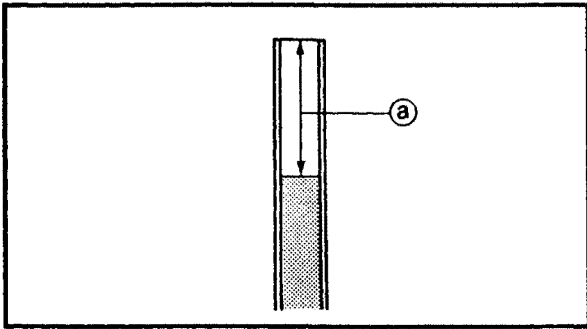

- 10.Fill:
 • Fork oil



Each fork:
 507 cm³ (17.8 Imp oz, 17.1 US oz)

Yamaha fork oil 10WT or equivalent. After filling up, slowly pump the fork up and down to distribute the fork oil.

Oil level ①:
 95 mm (3.74 in)
 (from the top of the inner tube fully compressed and without the fork spring)

NOTE: _____
 Hold the fork in an upright position.

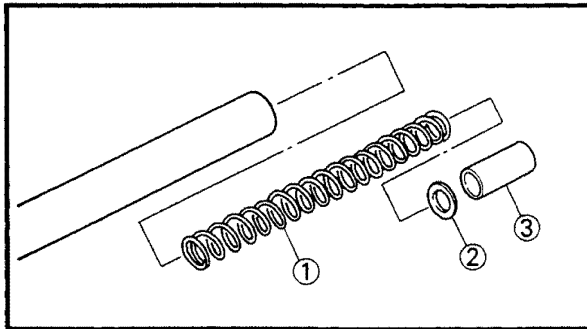

- 11.Install:
 • Fork spring ①
 • Spring seat ②
 • Spacer collar ③
 • O-ring
 • Cap bolt

NOTE: _____
 • Before installing the cap bolt, apply grease to the O-ring.
 • Temporarily tighten the cap bolt.

FRONT FORK INSTALLATION

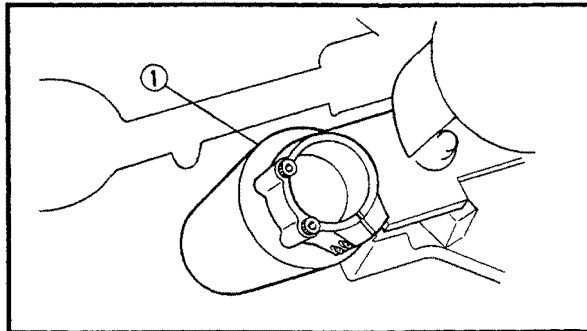

- 1.Install:
 • Lower fork covers ①
 • Front forks
 Temporarily tighten the lower bracket pinch bolts.

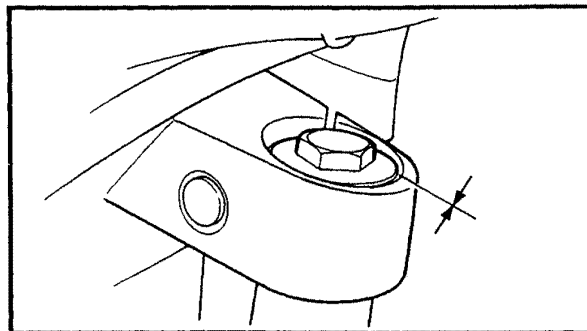

- 2.Install:
 • Upper bracket
 • Steering stem nut
110 Nm (11.0 m · kg, 79.6 ft · lb)

NOTE: _____
 • When aligning the fork tubes do not install the upper fork covers.
 • Make sure that the inner tube end is flush with the top of the handlebar crown.

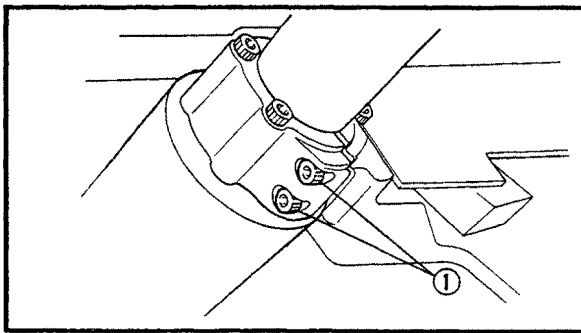

3. Tighten:

- Front fork pinch bolts (lower) ①

 23 Nm (2.3 m · kg, 17 ft · lb)

- Cap bolts

 23 Nm (2.3 m · kg, 17 ft · lb)

4. Remove:

- Steering stem nut
- Upper bracket

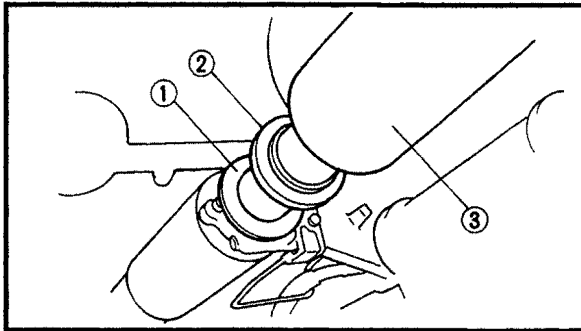

5. Install:

- Upper fork cover washers ①
- Upper fork cover spacers ②
- Upper fork covers ③

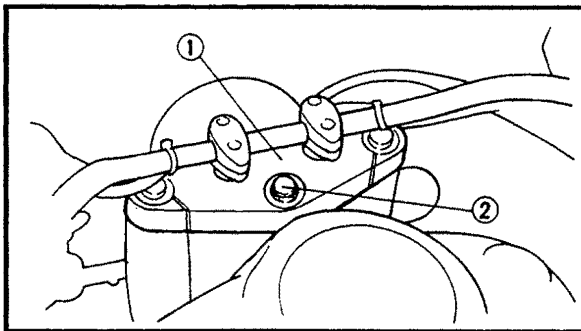

6. Install:

- Upper bracket ①
- Steering stem nut ②

 110 Nm (11.0 m · kg, 79.6 ft · lb)

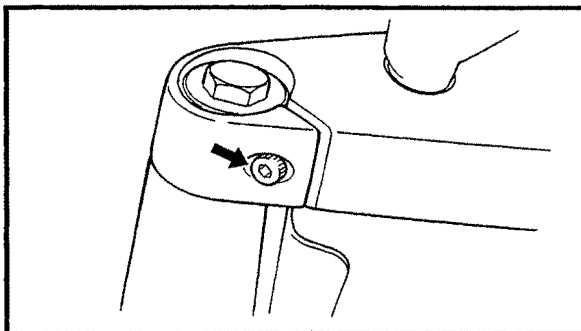

7. Tighten:

- Front fork pinch bolts (upper)

 23 Nm (2.3 m · kg, 17 ft · lb)

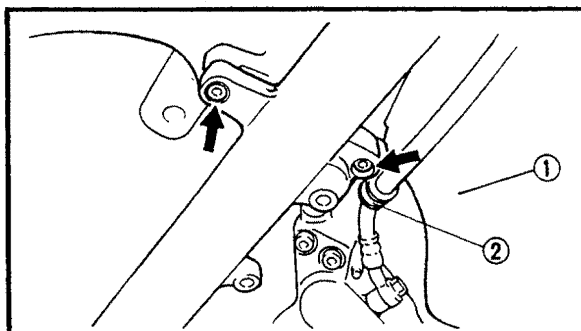

8. Install:

- Front fender ①
- Brake hose holders ②

HANDLEBAR

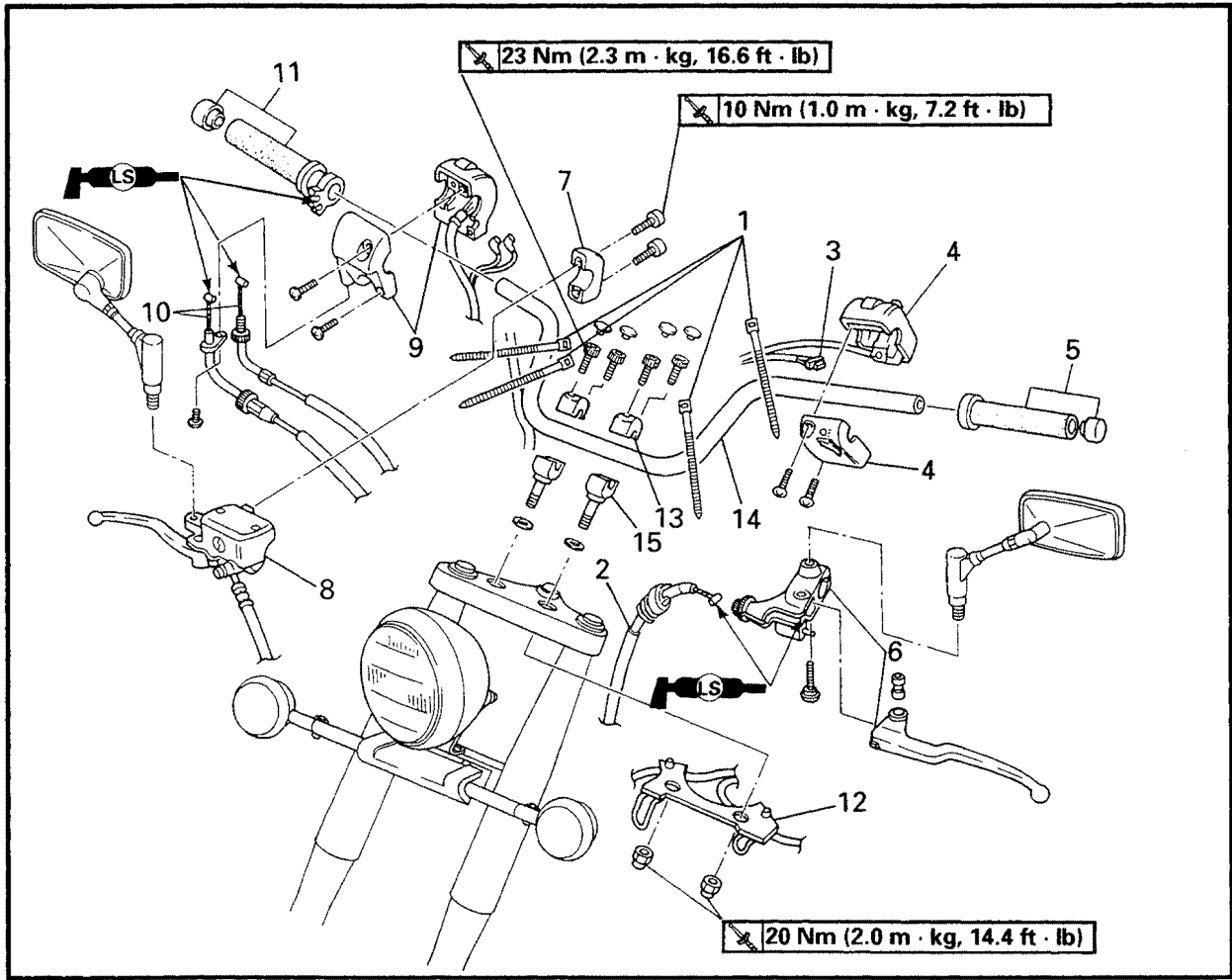

Order	Job name/Part name	Q'ty	Remarks
	Handlebar removal		Remove the parts in the order below. Stand the motorcycle on a level surface.
			⚠ WARNING Securely support the motorcycle so that there is no danger of it falling over.
1	Plastic locking ties	4	
2	Clutch cable	1	
3	Clutch switch lead	1	
4	Handlebar switch (left)	1	Refer to "HANDLEBAR INSTALLATION".
5	Grip (left)	1	
6	Clutch lever assembly	1	
7	Master cylinder bracket	1	
8	Master cylinder assembly	1	Refer to "HANDLEBAR INSTALLATION".
9	Handlebar switch (right)	1	
10	Throttle cables	2	

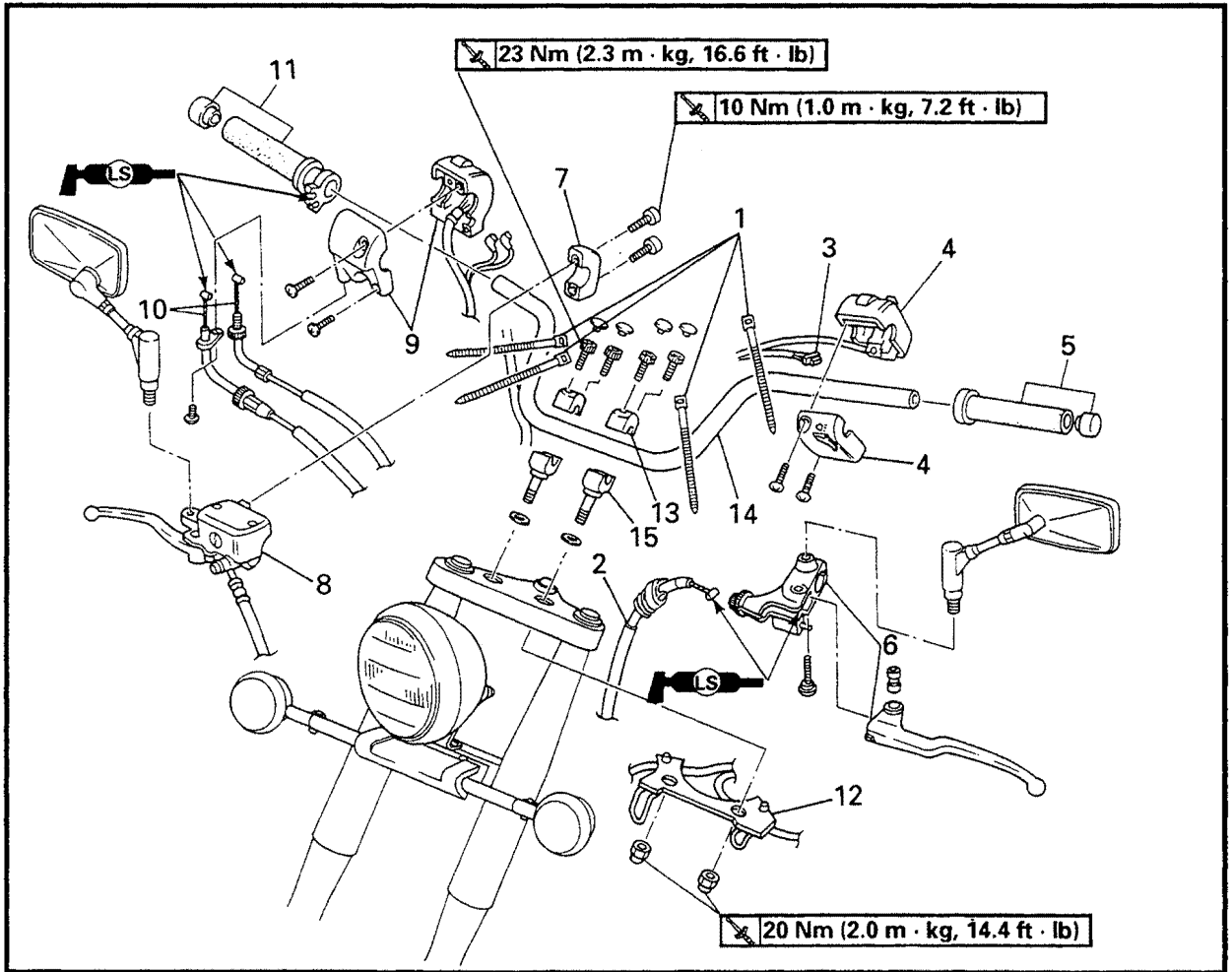

Order	Job name/Part name	Q'ty	Remarks
11	Throttle grip assembly	1	Refer to "HANDLEBAR INSTALLATION".
12	Cable guide	1	
13	Handlebar holder (upper)	2	
14	Handlebar	1	
15	Handlebar holder (lower)	2	
			For installation, reverse the removal procedure.

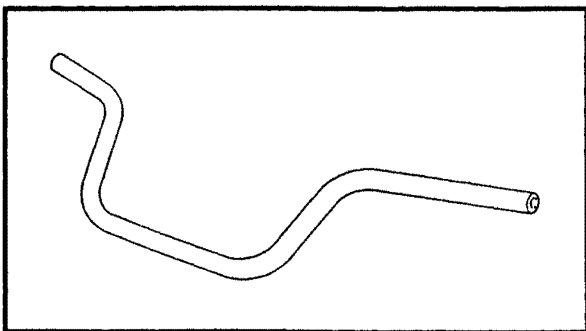

HANDLEBAR INSPECTION

1. Inspect:

- Handlebar
- Bends/cracks/damage → Replace.

CAUTION: _____
Do not attempt to straighten a bent handlebar as this may dangerously weaken it.

Left handlebar grip replacement steps:

- Remove the handlebar grip.
- Apply a light coat of rubber adhesive on the end of the handlebar.
- Install the handlebar grip.

NOTE: _____
 Wipe off excess adhesive with a clean rag.

⚠ WARNING _____
Do not touch the grip until the adhesive has set.

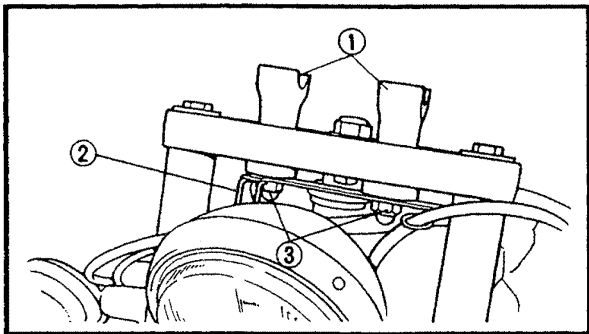

HANDLEBAR INSTALLATION

1. Install:

- Washers
- Handlebar holder (lower) ①
- Cable guide ②

NOTE: _____
 Temporarily tighten the nuts ③.

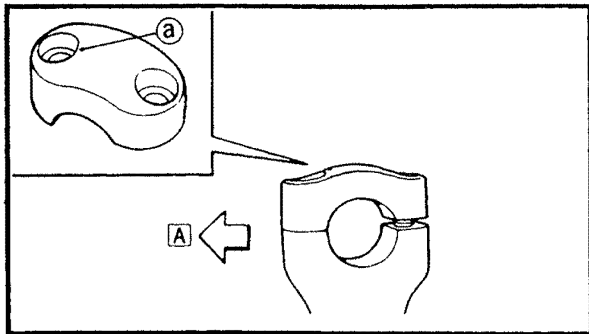

2. Install:

- Handlebar
- Handlebar holder (upper)

 **23 Nm (2.3 m · kg, 16.6 ft · lb)**

NOTE: _____
 ● The upper handlebar holder should be installed with the punch mark ① forward .

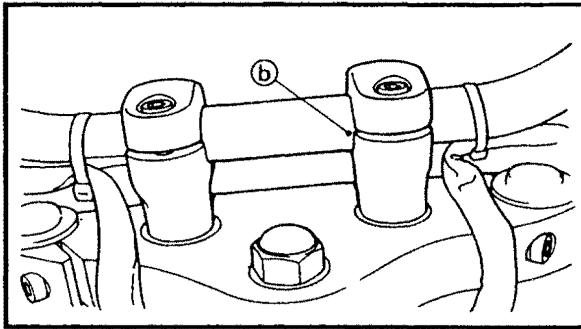

- Align the match marks (b) on the handlebar with the lower handlebar holder bolt hole.
- Apply a light coat of lithium soap base grease onto the right end of the handlebar.

CAUTION:

- First tighten the bolts on the front side of the handlebar holder, and then tighten the bolts on the rear side.
- Check the handlebar by turning it all the way to the left and then to the right. If there is any contact with the fuel tank, adjust the handlebar position.

3. Tighten:

- Nut (lower handlebar holder)

20 Nm (2.0 m · kg, 14.4 ft · lb)

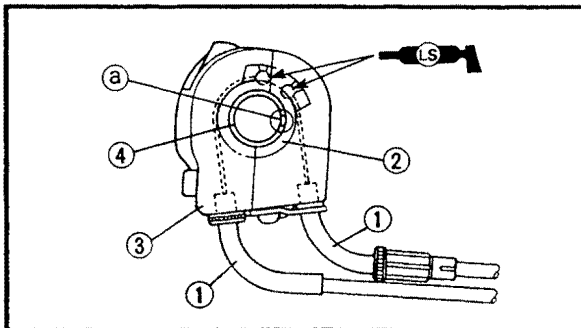

4. Install:

- Throttle cables (1)
- Throttle grip assembly (2)

NOTE:

Align the projection on the handlebar switch (right) (3) with the hole (a) in the handlebar (4).

5. Install:

- Master cylinder (front brake)
Refer to "MASTER CYLINDER (FRONT BRAKE)".

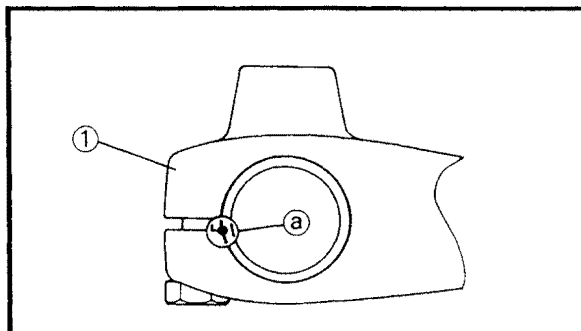

6. Install:

- Clutch lever holder (1)

NOTE:

Align the slit of clutch lever holder with the punch mark (a) on the handlebar.

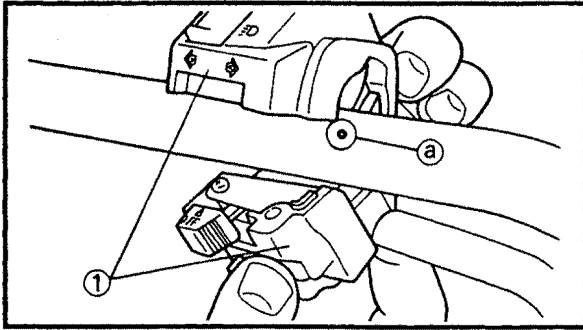
**7.Install:**

- Handlebar switch (left) ①

NOTE:

Align the matching surface of the handlebar switch (left) with the punch mark ② on the handlebar.

8.Adjust:

- Throttle cable free play
Refer to "THROTTLE CABLE ADJUSTMENT" in CHAPTER 3.

STEERING HEAD

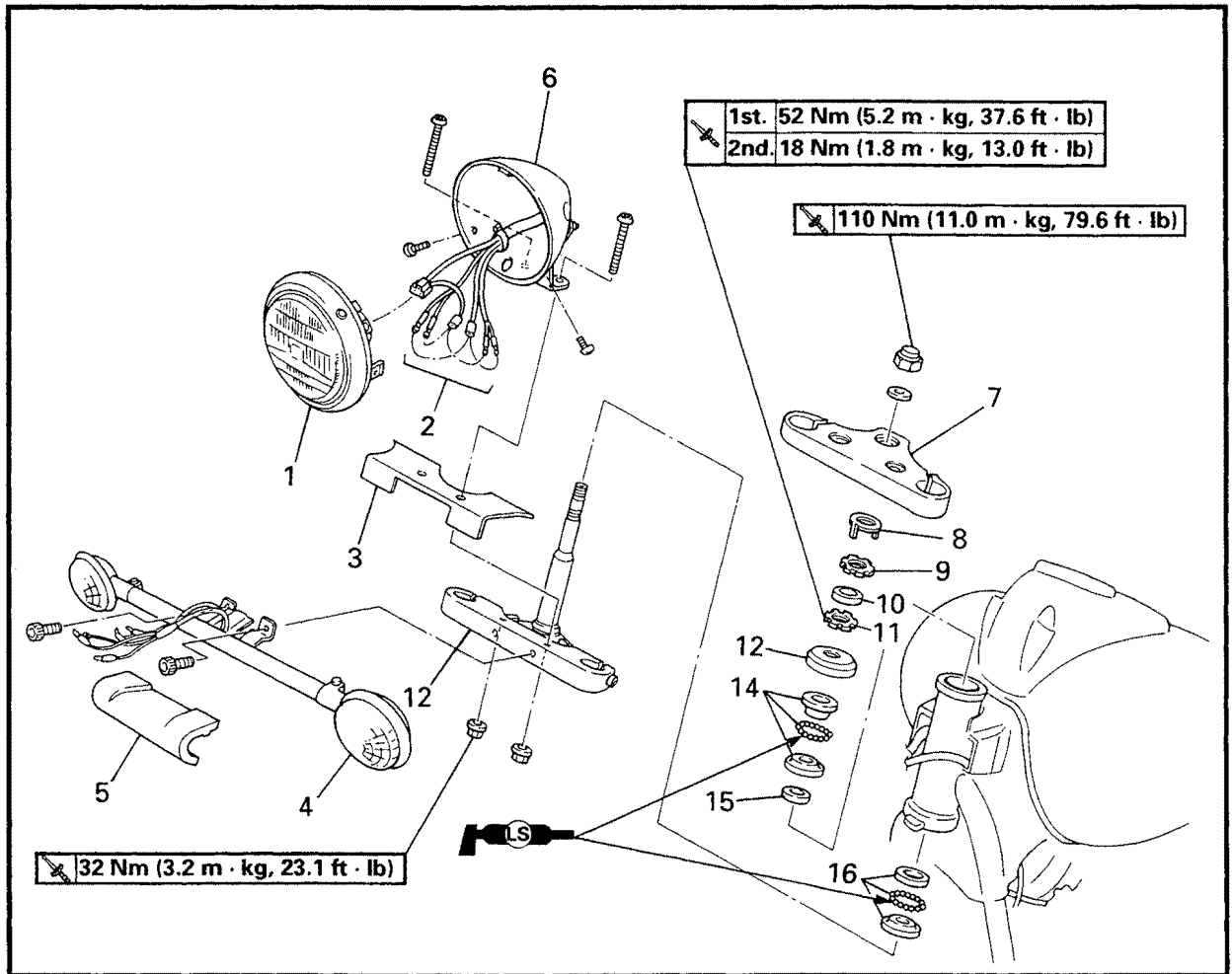

Order	Job name/Part name	Q'ty	Remarks
	Steering head removal		Remove the parts in the order below. Stand the motorcycle on a level surface.
			⚠ WARNING Securely support the motorcycle so that there is no danger of it falling over.
	Front forks		Refer to "FRONT FORK".
	Handlebar		Refer to "HANDLEBAR".
1	Headlight lens unit	1	
2	Leads (in the headlight body)	-	Disconnect
3	Front fork cover	1	
4	Front flasher light (left/right)	1/1	
5	Flasher bracket cover	1	
6	Headlight body	1	
7	Upper bracket	1	
8	Lock washer	1	
9	Upper ring nut	1	

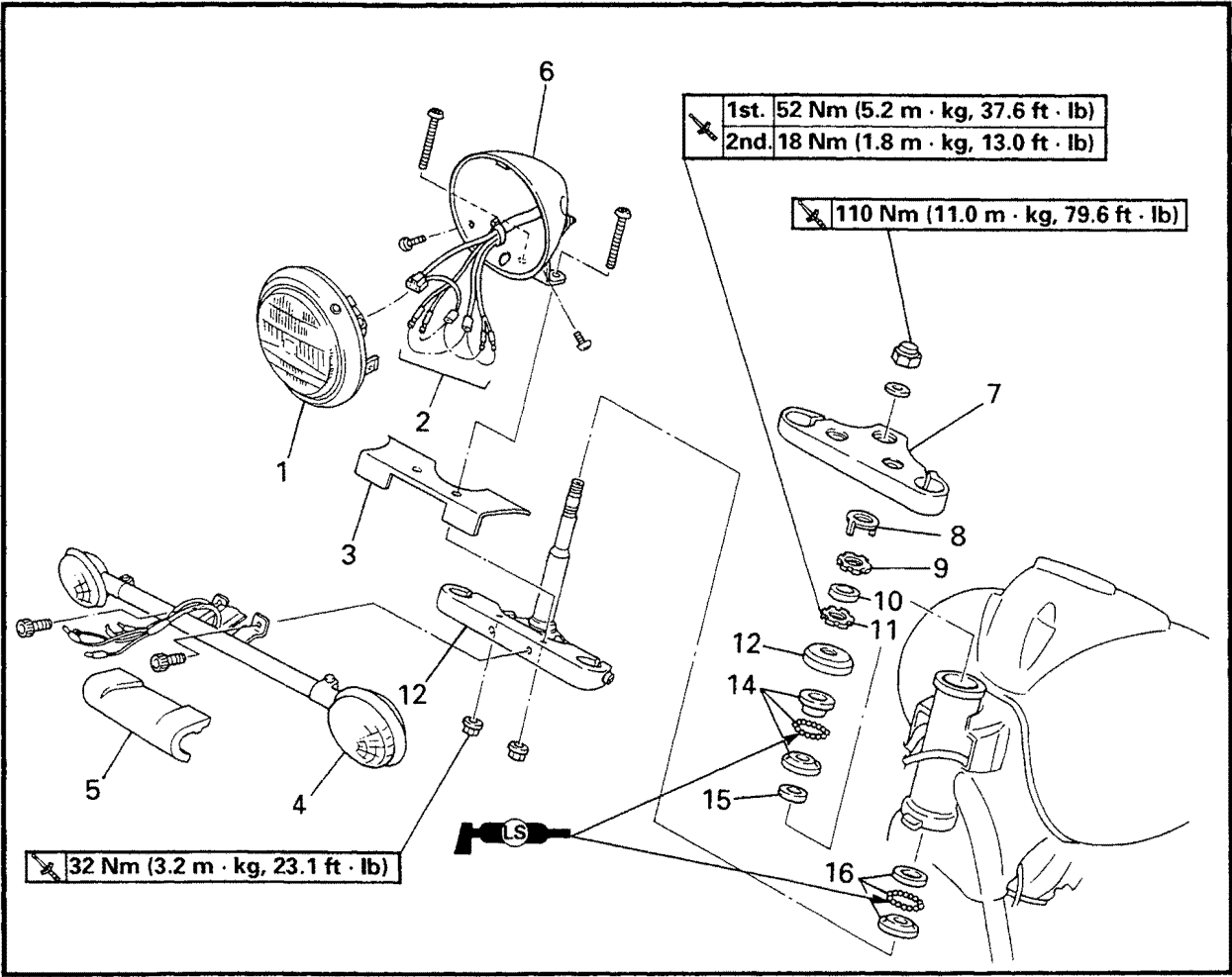

Order	Job name/Part name	Q'ty	Remarks
10	Rubber washer	1	Refer to "STEERING HEAD REMOVAL/INSTALLATION".
11	Lower ring nut	1	
12	Bearing cover	1	
13	Lower bracket	1	
14	Bearing (upper)	1	
15	Rubber seal	1	
16	Bearing (lower)	1	For installation, reverse the removal procedure.

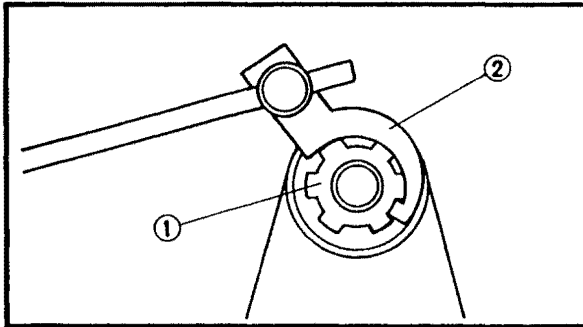

STEERING HEAD REMOVAL

1.Remove:

- Lower ring nut ①
Use the ring nut wrench ②.



Ring nut wrench:
YU-33975, 90890-01403

⚠ WARNING

Support the lower bracket so that it does not fall down.

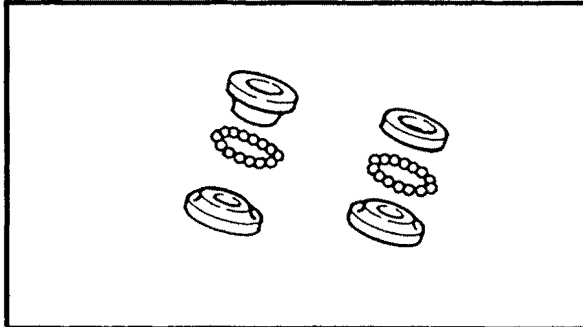

EB704020

STEERING HEAD INSPECTION

1.Wash the bearings and the bearing races with a solvent.

2.Inspect:

- Bearings
Pitting/damage → Replace.

Bearing and bearing race replacement steps:

- Remove the bearing races from the steering head pipe using a long rod ① and a hammer, as shown.
- Remove the bearing race on the lower bracket using a floor chisel ② and a hammer, as shown.
- Install the new rubber seal and races.

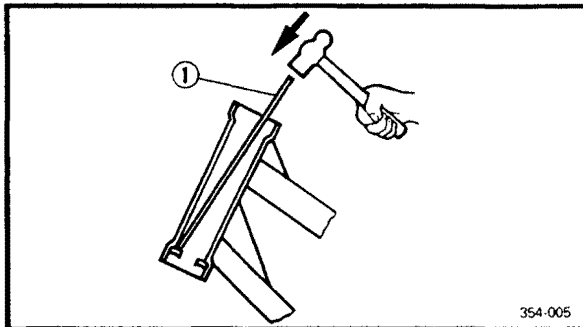

354-005

NOTE:

- Always replace the bearings and bearing races as a set.
- Whenever the steering head is disassembled replace the rubber seal.

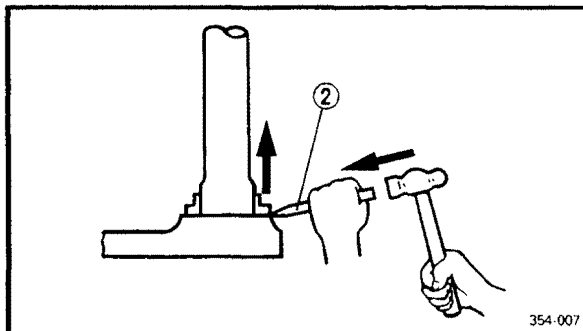

354-007

CAUTION:

If the bearing race is not fitted squarely, the steering head pipe could be damaged.

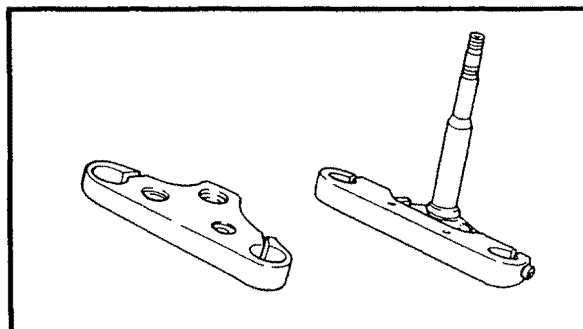

3.Inspect:

- Upper bracket
- Lower bracket
(with the steering stem)
Cracks/bends/damage → Replace.

EB704030

STEERING HEAD INSTALLATION

1.Tighten:

- Ring nuts (lower and upper)
Refer to "STEERING HEAD INSPECTION" in CHAPTER 3.

REAR SHOCK ABSORBER AND SWINGARM

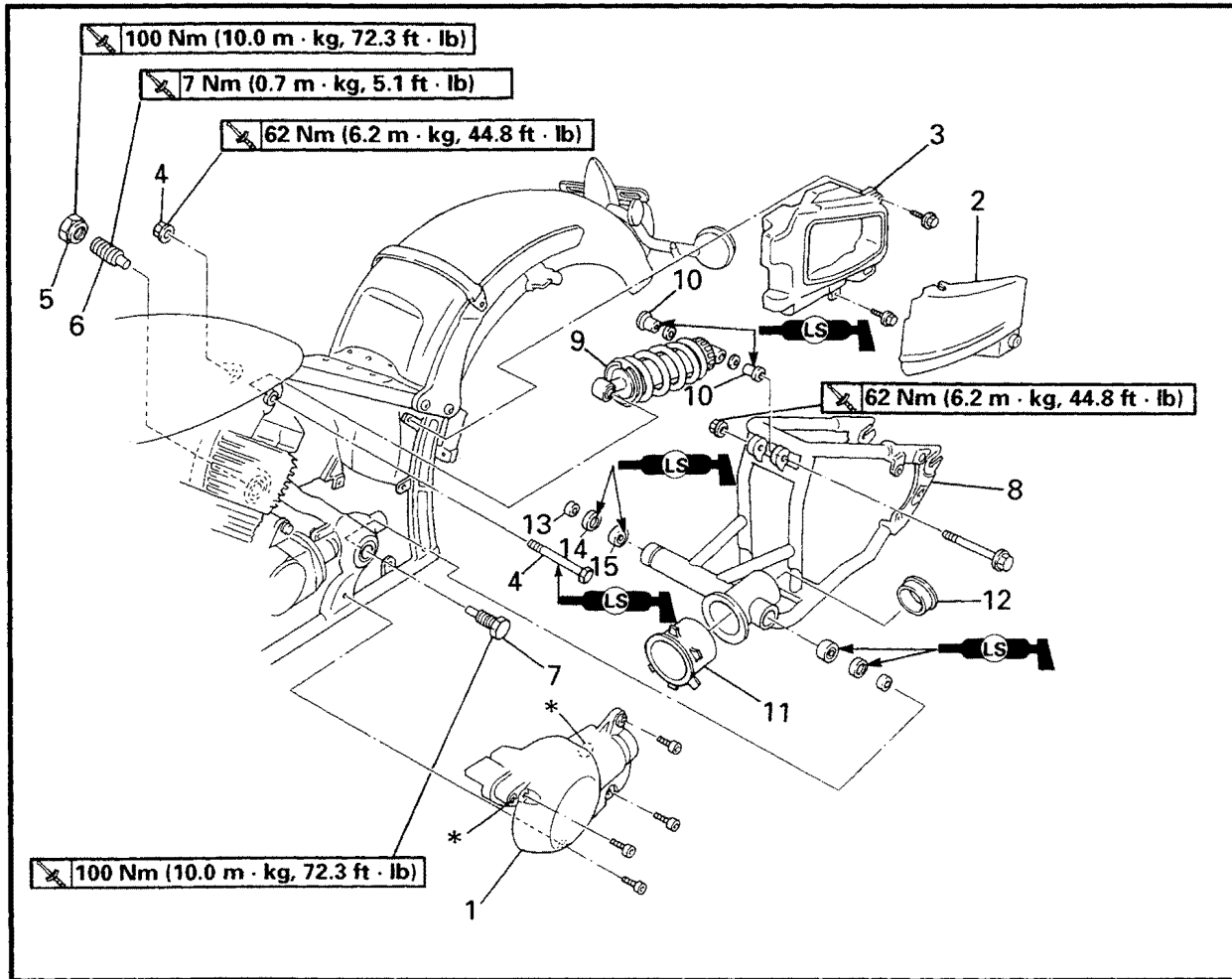

Order	Job name/Part name	Q'ty	Remarks
	Rear shock absorber and swingarm removal		Remove the parts in the order below. Stand the motorcycle on a level surface. ⚠ WARNING Securely support the motorcycle so there is no danger of it falling over.
	Seats		Refer to "FUEL TANK AND SEATS" in CHAPTER 3.
	Rear wheel		Refer to "REAR WHEEL".
	Final gear case		
	Muffler assembly		
	Battery cover		Refer to "ENGINE REMOVAL" in CHAPTER 4.
	Side cover (right)		
1	Side cover (left)	1	Do not remove the "*" bolts.
2	Tool box cover	1	

REAR SHOCK ABSORBER AND SWINGARM

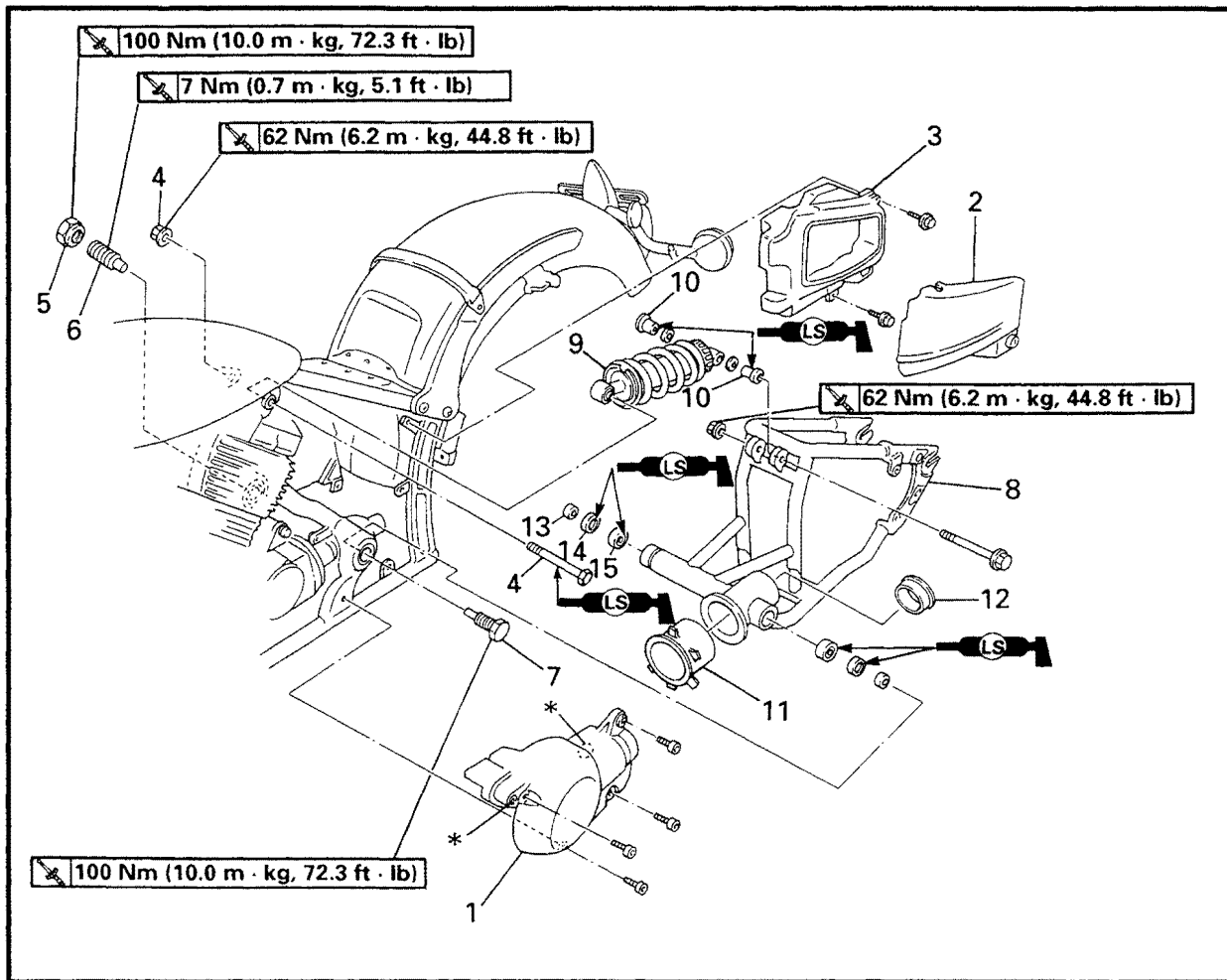

Order	Job name/Part name	Q'ty	Remarks
3	Tool box	1	
4	Bolt/nut (rear shock absorber - upper)	1/1	
5	Pivot shaft nut	1	Loosen
6	Pivot shaft (right)	1	Refer to "SWINGARM INSTALLATION".
7	Pivot shaft (left)	1	
8	Swingarm	1	
9	Rear shock absorber	1	Refer to "REAR SHOCK ABSORBER INSTALLATION".
10	Collars	2	
11	Rubber boot	1	
12	Bushing	1	
13	Collars	2	
14	Oil seals	2	
15	Bearings	2	
			For installation, reverse the removal procedure.

HANDLING NOTES

⚠ WARNING

This shock absorber contains highly compressed nitrogen gas. Read and understand the following information before handling the shock absorber. The manufacturer cannot be held responsible for property damage or personal injury that may result from improper handling.

1. Do not tamper or attempt to open the cylinder assembly.
2. Do not subject shock absorber to an open flame or other high heat. This may cause the unit to explode due to excessive gas pressure.
3. Do not deform or damage the cylinder in any way. Cylinder damage will result in poor damping performance.

NOTES ON DISPOSAL

Shock absorber disposal steps:

- Gas pressure must be released before disposing of the shock absorber. To do so, drill a 2 ~ 3 mm hole through the cylinder wall as shown.

⚠ WARNING

Wear eye protection to prevent eye damage from escaping gas and/or metal chips.

REAR SHOCK ABSORBER INSPECTION

1. Inspect:

- Rear shock absorber rod
Bends/damage → Replace the rear shock absorber assembly.
- Rear shock absorber
Oil leaks/gas leaks → Replace the rear shock absorber assembly.
- Spring
Wear/damage → Replace the rear shock absorber assembly.
- Bushings
Damage/scratches → Replace.
- Collars
Damage/scratches → Replace.
- Dust seals
Wear/damage → Replace.
- Bolts
Wear/bends/damage → Replace.

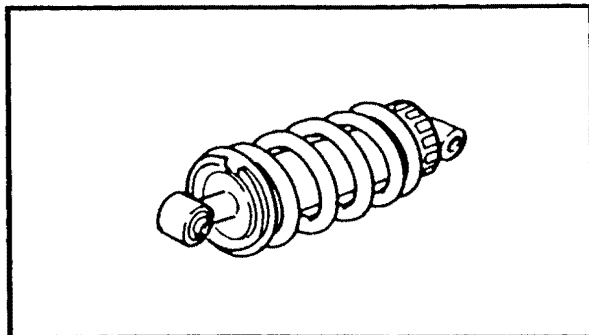
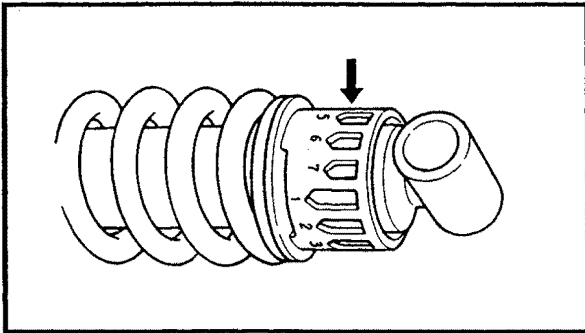

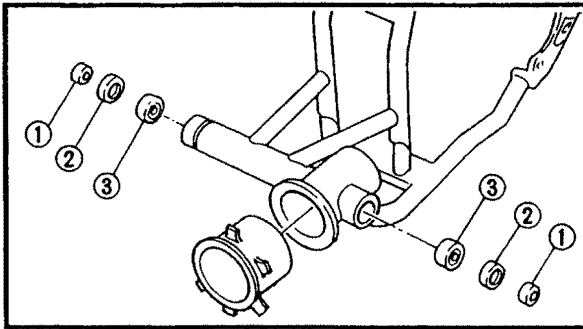

2. Inspect:

- Collars ①
 - Oil seals ②
 - Bearings ③
 - Rubber boot ④
- Wear/damage → Replace.

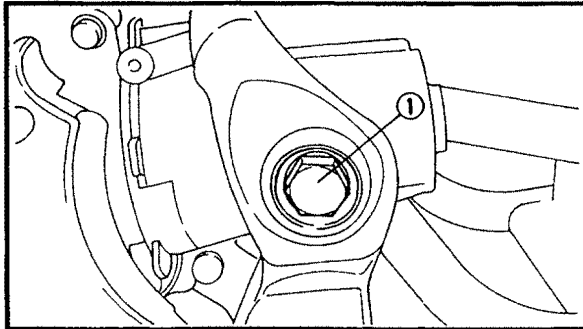

SWINGARM INSTALLATION

1. Install:

- Swingarm
- Pivot shaft (left) ①
- Pivot shaft (right) ②
- Pivot shaft nut ③

Tightening steps:

- Tighten the pivot shaft (left) ① to specification.

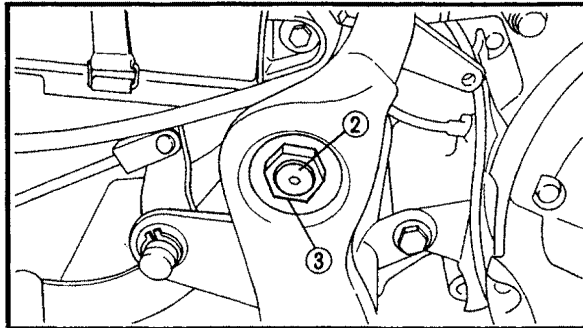

	<p>Pivot shaft (left): 100 Nm (10 m · kg, 72.3 ft · lb) LOCTITE®</p>
---	---

- Tighten the pivot shaft (right) ② until it contacts the collar.

	<p>Pivot shaft (right): 7 Nm (0.7 m · kg, 5.1 ft · lb)</p>
--	---

- Tighten the pivot shaft nut ③ to specification.

	<p>Pivot shaft nut: 100 Nm (10 m · kg, 72.3 ft · lb)</p>
--	---

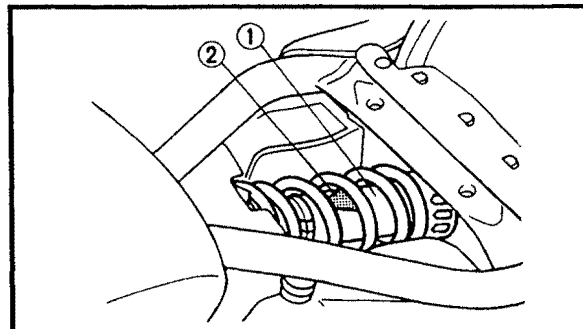

REAR SHOCK ABSORBER INSTALLATION

1. Install:

- Rear shock absorber ①

	<p>62 Nm (6.2 m · kg, 44.8 ft · lb)</p>
---	--

NOTE:

Install the rear shock absorber with the warning label ② facing up.

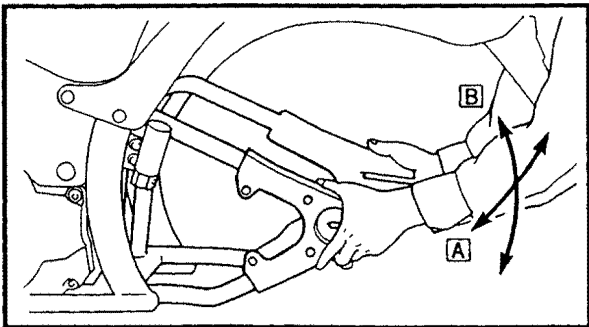

SWINGARM INSPECTION

1. Check:

- Swingarm free play

Inspection steps:

- Check the tightening torque of the swingarm pivot shaft securing nuts.



Securing nut (swingarm pivot shaft):

Left:

100 Nm (10 m · kg, 72.3 ft · lb)

Right:

7 Nm (0.7 m · kg, 5.1 ft · lb)

Right - nut:

100 Nm (10 m · kg, 72.3 ft · lb)

- Check the swingarm side play **A** by moving the swingarm from side to side. If side play is noticeable, check the inner collar, bearing, washer and thrust cover.



Side play (at swingarm end):
Zero mm

- Check the swingarm vertical movement **B** by moving it up and down. If vertical movement is not smooth or if there is binding, check the inner collar, bearing, washer and thrust cover.

2. Inspect:

- Swingarm
Cracks/bends/damage → Replace.

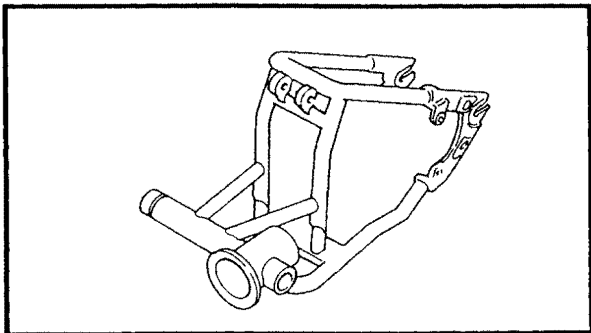

3. Inspect:

- Pivot shafts
Damage/wear → Replace.

NOTE: _____
Wash the swingarm pivoting parts in a solvent.

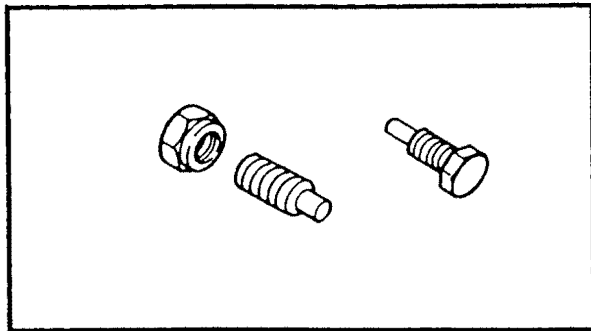



SHAFT DRIVE

EB707010

TROUBLESHOOTING

The following conditions may indicate damaged shaft drive components:

A	Symptoms	B	Possible causes
1.	A pronounced hesitation or jerky movement during acceleration, deceleration, or sustained speeds (This must not be confused with engine surging or transmission-related movements.)	A.	Bearing damage
2.	A rolling "rumble" noticeable at low speeds, a high-pitched whine, or a "clunk" from a shaft drive component or area	B.	Improper gear lash
3.	A locked-up condition of the shaft drive mechanism or no power transmitted from the engine to the rear wheel	C.	Damaged gear teeth
		D.	Broken drive shaft
		E.	Broken gear teeth
		F.	Seizure due to lack of lubrication
		G.	Small foreign objects lodged between moving parts

NOTE:

Causes A, B and C may be extremely difficult to diagnose. The symptoms are quite subtle and difficult to distinguish from normal operating noises. If there is reason to believe these components are damaged, remove them for individual inspection.

Inspection notes

1. Investigate any unusual noises.

The following noises may indicate a mechanical defect:

a. A rolling "rumble" during coasting, acceleration, or deceleration. The noise increases with rear wheel speed, but does not increase with higher engine or transmission speeds.

Diagnosis: Possible wheel bearing damage

b. A whining noise that varies with acceleration and deceleration.

Diagnosis: Possible incorrect reassembly, too little gear lash

CAUTION:

Insufficient gear lash is extremely destructive to the gear teeth. If a test ride following reassembly indicates this condition, stop riding immediately to minimize gear damage.

c. A slight "clunk" evident at low speed operation. This noise must be distinguished from normal motorcycle operation.

Diagnosis: Possible broken gear teeth

WARNING

Stop riding immediately if broken gear teeth are suspected. This condition could result in a locking of the shaft drive assembly, causing loss of control of the motorcycle and possible injury to the rider.

2. Inspect:

- Drained oil

Drained oil contains a large amount of metal particles → Check the bearing for seizure.

NOTE:

A small amount of metal particles in the oil is normal.

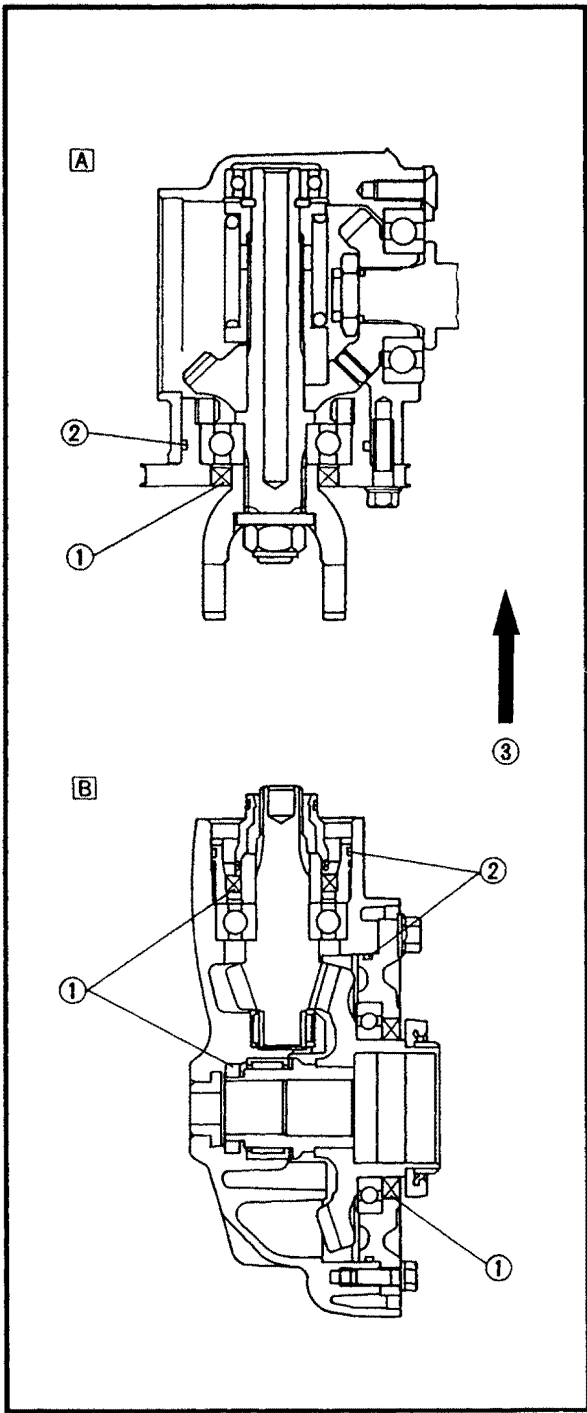

3. Inspect:

- Oil leakage

Inspection steps:

- Clean the entire motorcycle thoroughly, then dry it.
- Apply a leak-locating compound or dry powder spray to the shaft drive.
- Road test the motorcycle for the distance necessary to locate the leak.
Leakage → Inspect the component housing, gasket and/or seal for damage.
Damage → Replace the component.

- ① Oil seal
- ② O-ring
- ③ Forward
- Ⓐ Middle gear
- Ⓑ Final gear

NOTE:

- An apparent oil leak on a new or nearly new motorcycle may result from the application of a rust preventive coating or excessive seal lubrication.
- Always clean the motorcycle and recheck the suspected location of an apparent leak.

**Troubleshooting chart**

When causes A and B shown in the chart at the beginning of the "TROUBLESHOOTING" section exist, check the following points:

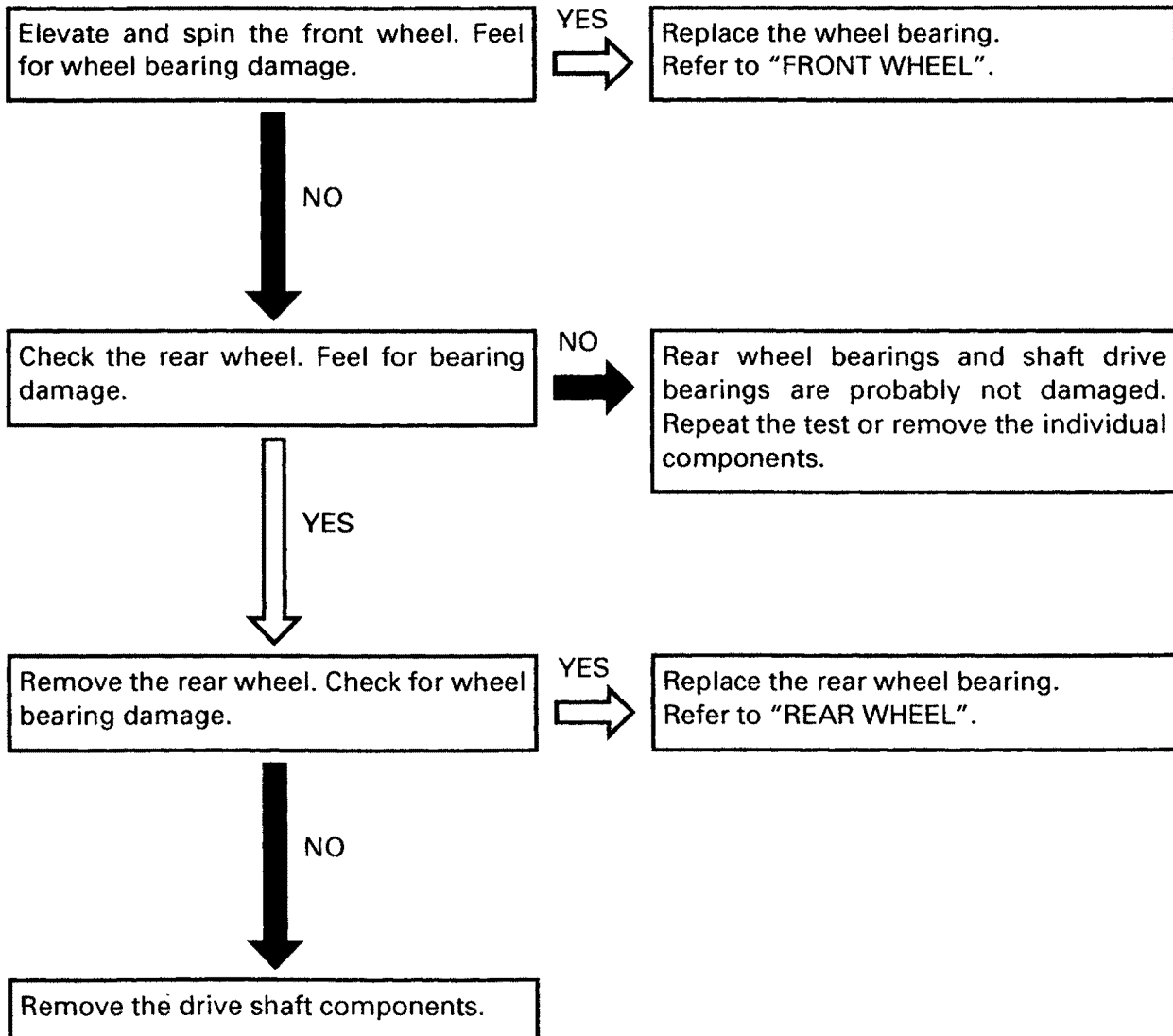

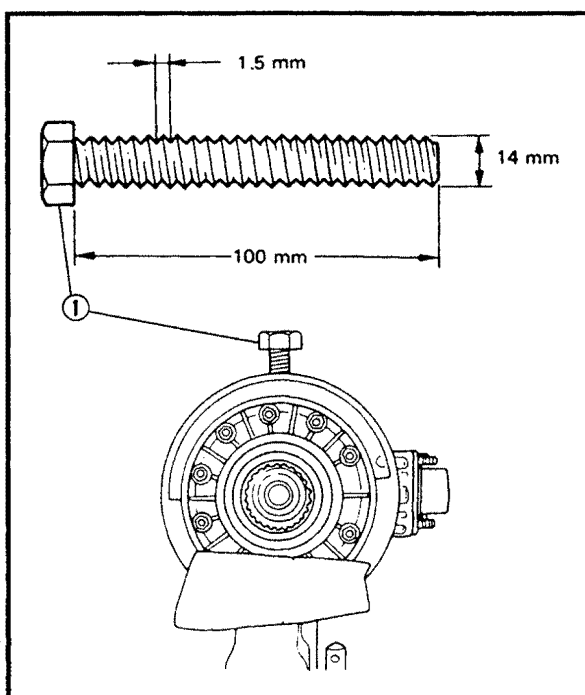

EB707030

FINAL GEAR BACKLASH MEASUREMENT

1. Secure the final drive gear case in a vise or a similar supporting device.
2. Remove:
 - Drain plug
 - Drain the oil.
3. Install:
 - Specified bolt ① (into the drain plug hole)
4. Finger tighten the bolt until it holds the ring gear.

NOTE:

Do not overtighten the bolt; just finger-tighten it.

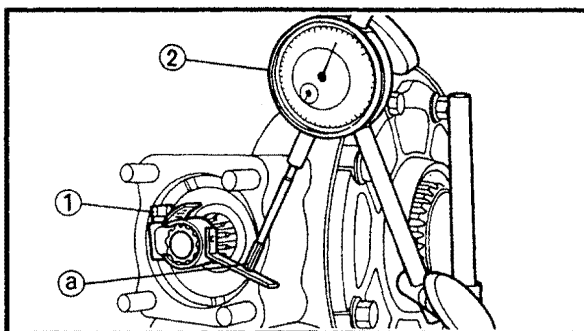

5. Attach:

- Final gear backlash band ①
- Dial gauge ②



Final gear backlash band:
YM-01231, 90890-01231

- Position mark ③

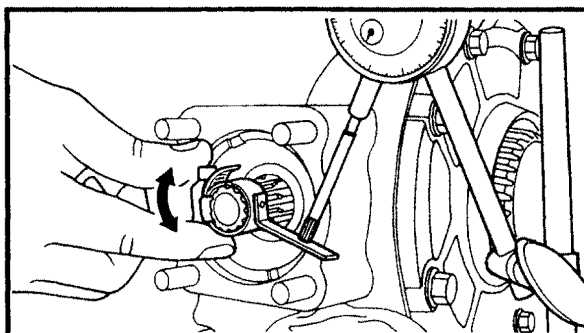

6. Measure:

- Final gear backlash
Gently rotate the final drive gear coupling from engagement to engagement.
Over the specified limit → Adjust.



Final gear backlash:
0.1 ~ 0.2 mm (0.004 ~ 0.008 in)

NOTE:

Measure the final gear backlash at four positions. Rotate the final drive shaft 90° each time.

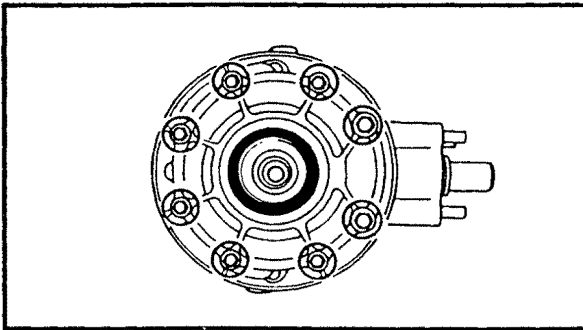

EB707031

FINAL GEAR BACKLASH ADJUSTMENT

1.Remove:

- Bolts (bearing housing)

NOTE:

Working in a crisscross pattern, loosen each nut 1/4 of a turn. After all the nuts are loosened, remove them.

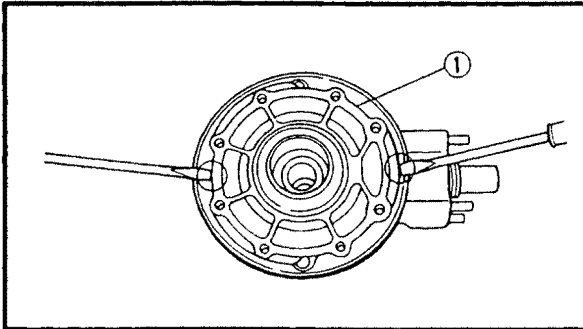

2.Remove:

- Bearing housing ①
- Ring gear ②
- Thrust washer ③
- Shim(s) ④

3.Adjust:

- Final gear backlash

Adjustment steps:

- Use the following chart to select the suitable shims and thrust washer.

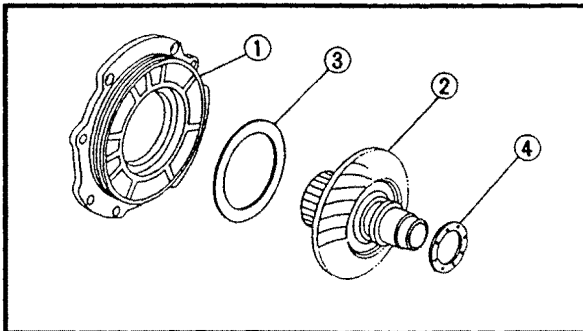

Reducing the shim thickness:	gear backlash is increased.
Increasing the shim thickness:	gear backlash is decreased.

- If it is necessary to increase the final gear backlash by more than 0.1 mm:
Reduce the thrust washer thickness by 0.1 mm for every 0.1 mm increase of ring gear shim thickness.
- If it is necessary to reduce the final gear backlash by more than 0.1 mm:
Increase the thrust washer thickness by 0.1 mm for every 0.1 mm decrease of ring gear shim thickness.

	Ring gear shim
Thickness (mm)	0.25, 0.30, 0.40

	Thrust washer
Thickness (mm)	1.2, 1.4, 1.6, 1.8, 2.0

DRIVE SHAFT

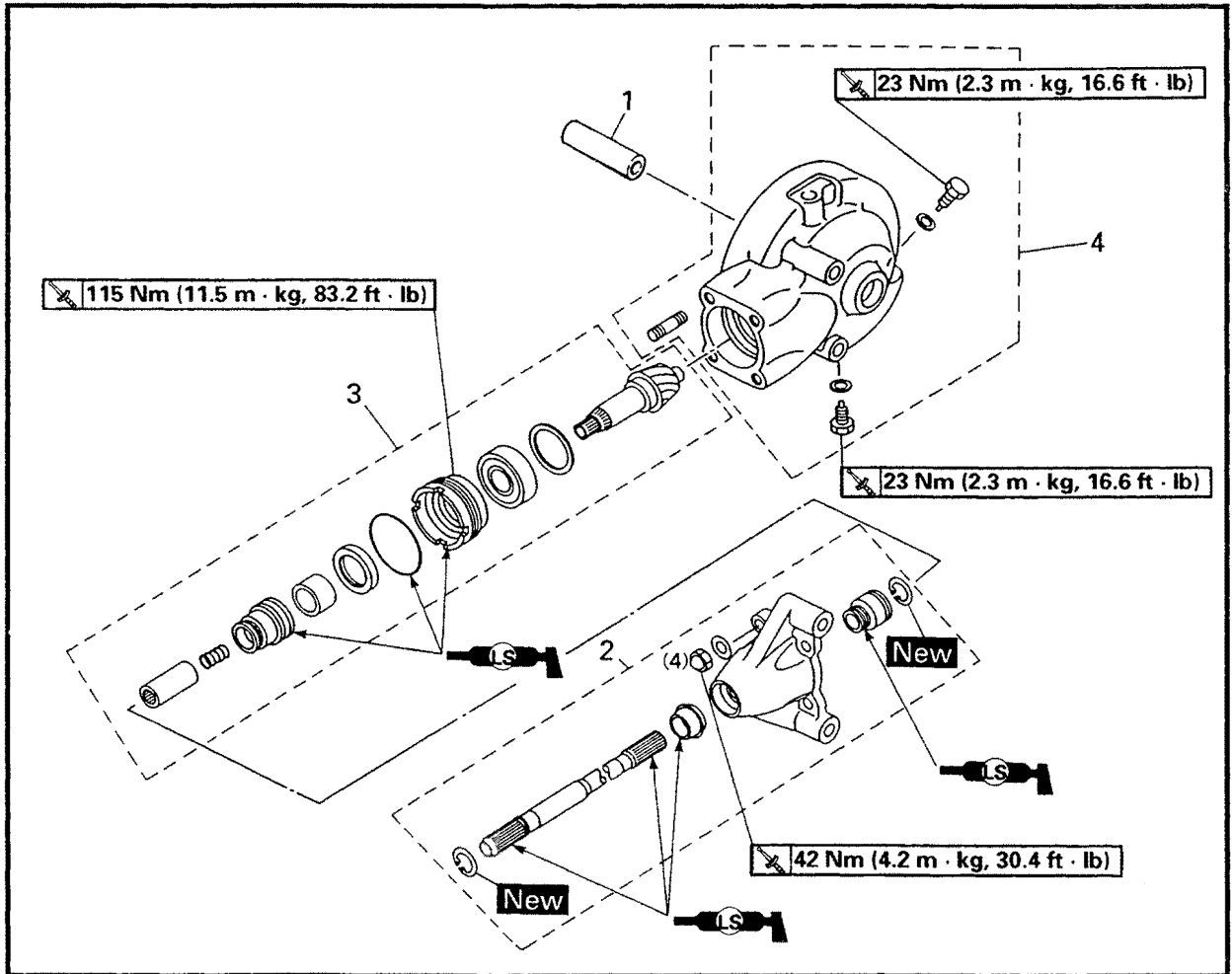

Order	Job name/Part name	Q'ty	Remarks
	Drive shaft removal		Remove the parts in the order below. Stand the motorcycle on a level surface. ⚠ WARNING _____ Securely support the motorcycle so there is no danger of it falling over.
	Rear wheel assembly		Refer to "REAR WHEEL".
1	Collar	1	
2	Drive shaft assembly	1	
3	Final drive pinion gear assembly	1	Refer to "FINAL DRIVE GEAR DISASSEMBLY".
4	Final gear assembly	1	For installation, reverse the removal procedure.

FINAL GEAR

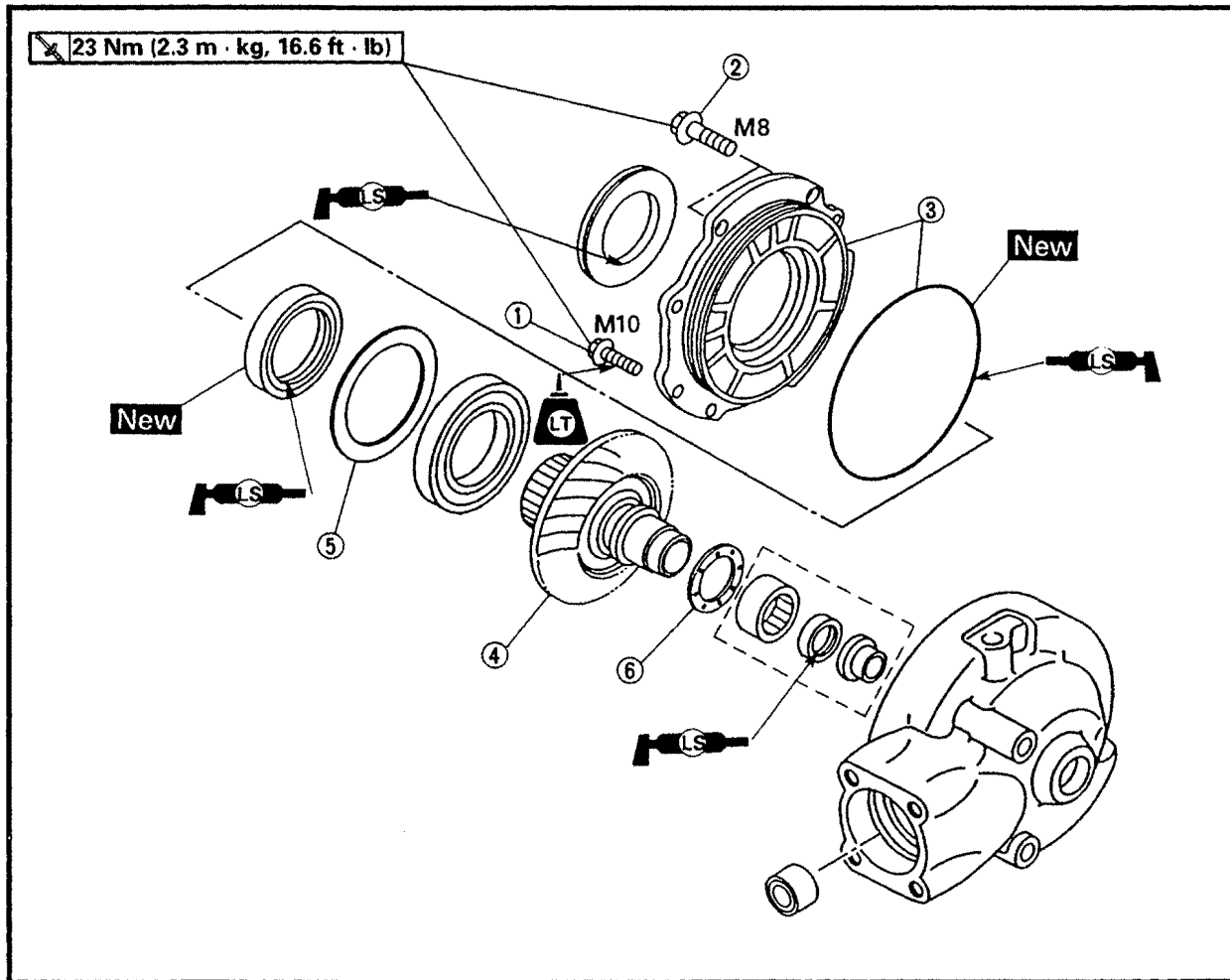

Order	Job name/Part name	Q'ty	Remarks
	Final gear disassembly		Disassemble the parts in the order below.
①	Bolts (bearing housing)	2	NOTE: _____ Working in a crisscross pattern, loosen each bolt 1/4 of a turn. After all the bolts are loosened, remove them.
②	Bolt (bearing housing)	6	
③	Bearing housing/O-ring	1/1	
④	Ring gear	1	
⑤	Thrust washer	1	
⑥	Shim(s)	1	
			For assembly, reverse the disassembly procedure.

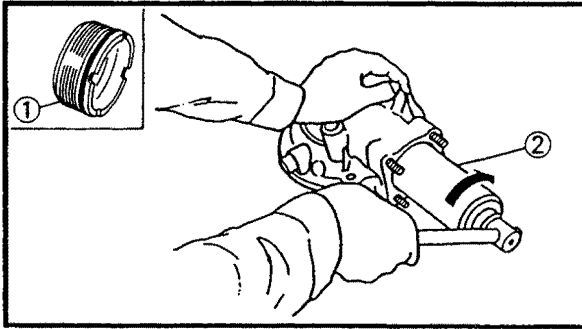

FINAL DRIVE GEAR DISASSEMBLY

1.Remove:

- Bearing retainer (final drive shaft)
Use a bearing retainer wrench ①.



Bearing retainer wrench:
YM-04050, 90890-04050

CAUTION:

The final drive shaft bearing retainer has left-handed threads. To loosen the retainer turn it clockwise.

2.Remove:

- Final drive shaft assembly
With a soft hammer lightly tap on the final drive shaft end.

CAUTION:

Removal of the final drive shaft should only be performed if gear replacement is necessary.

⚠ WARNING

Always use new bearings and races.

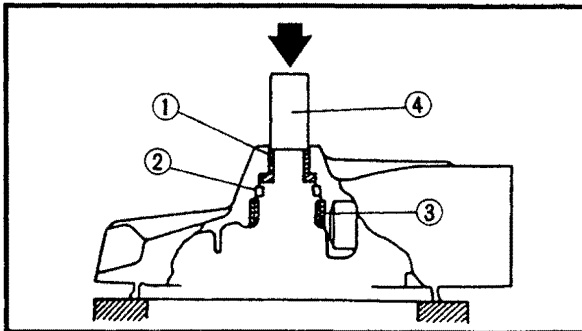

EB707033

FINAL DRIVE ROLLER BEARING REMOVAL AND REASSEMBLY

1.Remove:

- Guide collar ①
- Oil seal ②
- Roller bearing ③

Use a suitable press tool ④ and an appropriate support for the final gear case.

2.Inspect:

- Final drive roller bearing

NOTE:

The roller bearing can be reused, but Yamaha recommends installation of a new bearing. Do not reuse the oil seal.

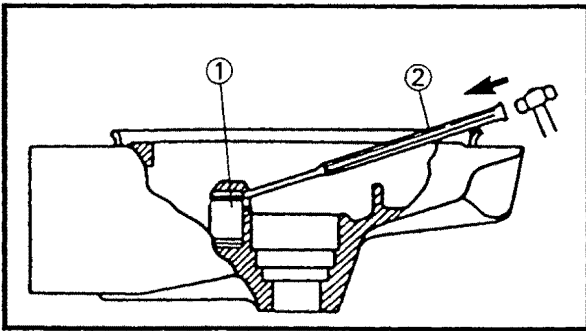

3.Remove:

- Final drive roller bearing ①

Removal steps:

- Heat the final gear case to 150°C (302°F).
- Using an appropriately shaped punch ② remove the roller bearing outer races.
- Remove the inner race from the final drive shaft.

NOTE:

The removal of the final drive shaft roller bearing is a difficult procedure and is rarely necessary.

4.Install:

- Final drive roller bearing (new)

Installation steps:

- Heat the final gear case to 150 °C (302°F).
- Install the roller bearing outer races using the proper adapter.
- Install the inner race onto the drive shaft.

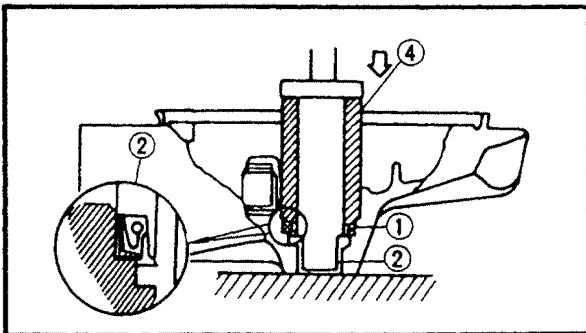

5.Install:

- Guide collar ①
- Oil seal ② **New**
- Roller bearing (outer race) ③

To install the above components into the final gear case use a suitable press tool ④ and a press.

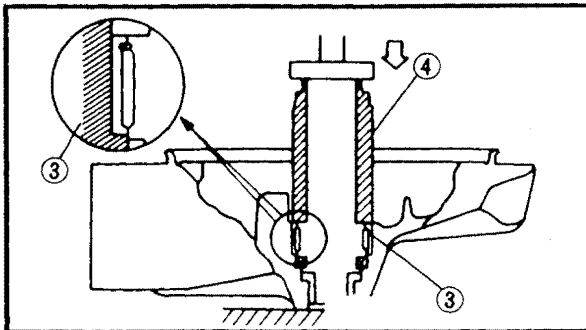

EB707034

FINAL DRIVE/RING GEAR POSITIONING

NOTE:

Ring gear positioning is necessary when any of the following parts are replaced:

- Final gear case
- Ring gear bearing housing
- Bearing(s)

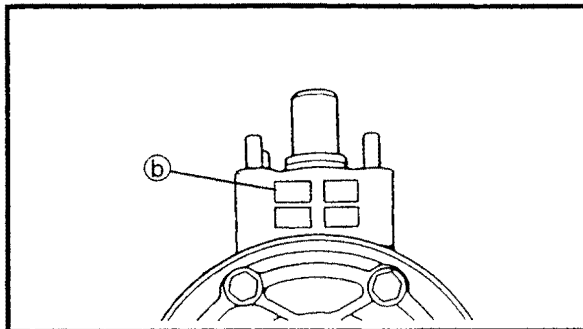
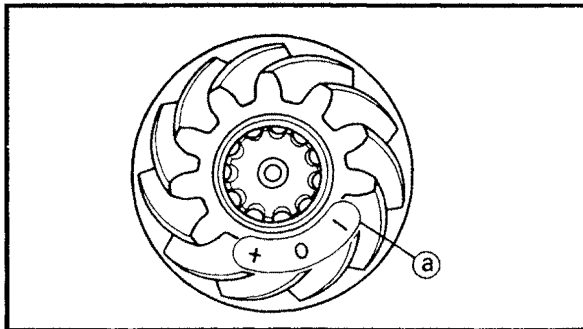
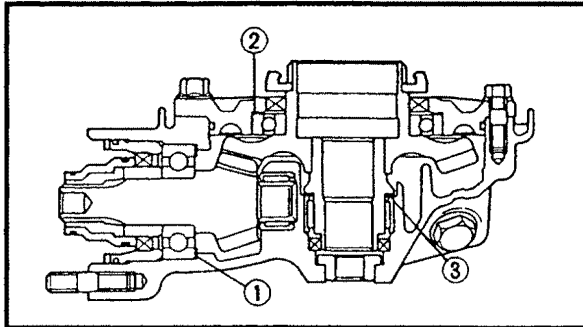

1. Select:

- Final drive gear shim ①
- Ring gear shim ②

Selection steps:

● Position the final drive gear and the ring gear by using shims ① and ② with their respective thicknesses calculated from information marked on the final gear case and the drive gear end.

- ① Final drive gear shim thickness "A"
- ② Ring gear shim thickness "B"
- ③ Thrust washer "C"

● To find the final drive gear shim thickness "A", use the following formula

Final drive gear shim thickness:
 $A = a - b$

Where:

① = a numeral (usually a decimal number) on the final drive pinion gear is either added to or subtracted from "80".

② = a numeral on the final drive gear case (i.e. 79.50)

Example:

① is 80.01

If the final gear case is marked "50".....② is 79.50.

$$\begin{aligned}
 "A" &= 80.01 - 79.50 \\
 &= 0.51
 \end{aligned}$$

Therefore, final drive gear shim thickness is 0.51 mm (0.02 in). Shim sizes are supplied in the following thickness.

 Final drive gear shim	
Thickness (mm)	0.40, 0.50
(in)	(0.016, 0.02)

Since final drive gear shims can only be selected in 0.10 mm (0.003 in) increments, round off the hundredths digit and select the appropriate shim(s).

Hundredths	Rounded value
0, 1, 2, 3, 4	0
5, 6, 7, 8, 9	10

In the example above, the calculated final drive gear shim thickness is 0.51 mm (0.02 in). The chart instructs you to round off the 1 to 0. Thus you should use a 0.50 mm (0.02 in) final drive gear shim.

● To find the ring gear shim thickness "B", use the following formula.

Ring gear shim thickness:
 $B = \text{C} + \text{d} - (\text{e} + \text{f})$

Where:

- Ⓒ = a numeral on the final gear case (i.e.45.55)
- Ⓓ = a numeral on the bearing housing (i.e. 1.35)
- Ⓔ = a numeral (usually a decimalnumber) on the inside of the ring gear either added to or subtracted from "35.40".
- Ⓕ = the ring gear bearing thickness (considered constant).

 **Ring gear bearing thickness Ⓕ:**
 11 mm (0.43 in)

Example:

If the final gear case is marked "55".....Ⓒ is 45.55

Ⓓ is 1.35

If the ring gear is marked "-05".....Ⓔ is 35.35

Ⓕ is 11.00

$$\begin{aligned}
 \text{"B"} &= 45.55 + 1.35 - (35.35 + 11.00) \\
 &= 46.9 - (46.35) \\
 &= 0.55
 \end{aligned}$$

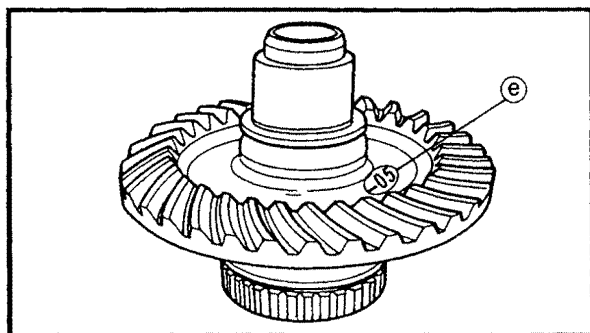
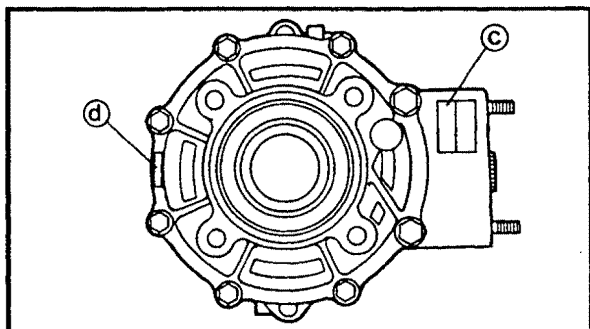

Therefore, the ring gear shim thickness is 0.55 mm (0.02 in). Shim sizes are supplied in the following thickness.

	Ring gear shim	
Thickness (mm)	0.25, 0.30, 0.40	

Since ring gear shims can only be selected in 0.10 mm (0.003 in) increments, round off the hundredths digit and select the appropriate shim(s).

Hundredths	Rounded value
0, 1, 2, 3, 4	0
5, 6, 7, 8, 9	10

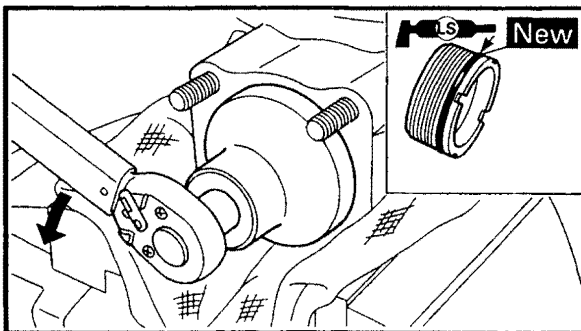

2.Install:

- Shims (proper size as calculated)
- Final drive shaft assembly
- Bearing retainer (final drive shaft)

 **115 Nm (11.5 m · kg, 83.2 ft · lb)**

Use a bearing retainer wrench.

CAUTION:

The final drive shaft bearing retainer has left-hand threads. Turn the retainer counterclockwise to tighten it.

	Bearing retainer wrench: YM-04050, 90890-04050
--	---

3.Adjust:

- Gear backlash
Refer to "FINAL GEAR BACKLASH MEASUREMENT" and "FINAL GEAR BACKLASH ADJUSTMENT".

4.Measure/select:

- Ring gear thrust washer clearance

Ring gear thrust washer clearance measurement steps:

- Remove the ring gear assembly.
- Place four pieces of Plastigauge® between the originally installed ring gear thrust washer and the ring gear.
- Install the ring gear assembly and tighten the bolts to specification.

	Bolt (bearing housing): 23 Nm (2.3 m · kg, 16.6 ft · lb)
---	--

NOTE:

When using Plastigauge® to measure the ring gear thrust washer clearance do not turn the shaft drive and ring gear.

- Remove the ring gear assembly.
- Measure the ring gear thrust washer clearance and the width of the flattened Plastigauge® ①.

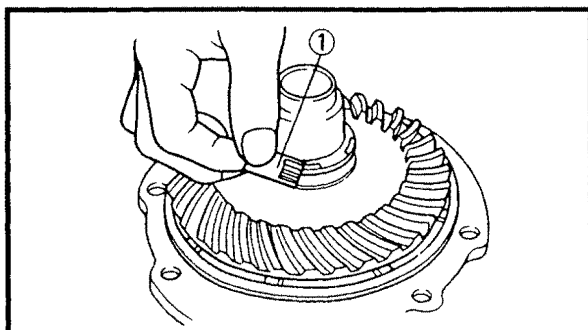

	Ring gear thrust washer clearance: 0.1 ~ 0.2 mm (0.004 ~ 0.008 in)
--	--

- If the clearance is correct, install the ring gear assembly.
- If out of specification, select the correct thrust washer.

Ring gear thrust washer selection steps:

- Using the following chart select the suitable thrust washer.

 Thrust washer	
Thickness (mm)	1.2, 1.4, 1.6, 1.8, 2.0

- Repeat the measurement steps until the ring gear thrust washer clearance is within the specified limits.

	Ring gear thrust washer clearance: 0.1 ~ 0.2 mm (0.004 ~ 0.008 in)
---	--

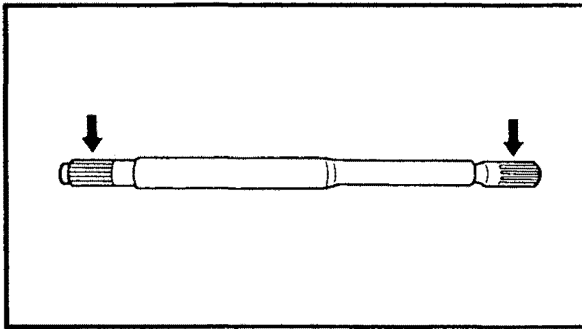

EB707040

DRIVE SHAFT INSPECTION

1. Inspect:

- Drive shaft splines
Wear/damage → Replace.

FINAL GEAR CASE INSTALLATION

1. Apply:

- Sealant
(onto the mating surface of both final gear case halves)



Yamaha Bond No. 1215:
ACC-1100-15-01, 90890-85505

EB800000

ELECTRICAL

ELECTRICAL COMPONENTS

- | | |
|---------------------------|-----------------------|
| ① Thermo switch | ⑨ Starter relay |
| ② Main switch | ⑩ Igniter unit |
| ③ Ignition coil | ⑪ Flasher relay |
| ④ Fuse | ⑫ Neutral switch |
| ⑤ Carburetor heater relay | ⑬ Rear brake switch |
| ⑥ Relay unit | ⑭ Side stand switch |
| ⑦ Battery | ⑮ Rectifier/regulator |
| ⑧ Headlight relay | ⑯ Horn |

IGNITION COIL:
 PRIMARY WINDING RESISTANCE:
 3.8 ~ 4.6 Ω at 20 °C (68°F)
 SECONDARY WINDING RESISTANCE:
 10.1 ~ 15.1 kΩ at 20 °C (68°F)

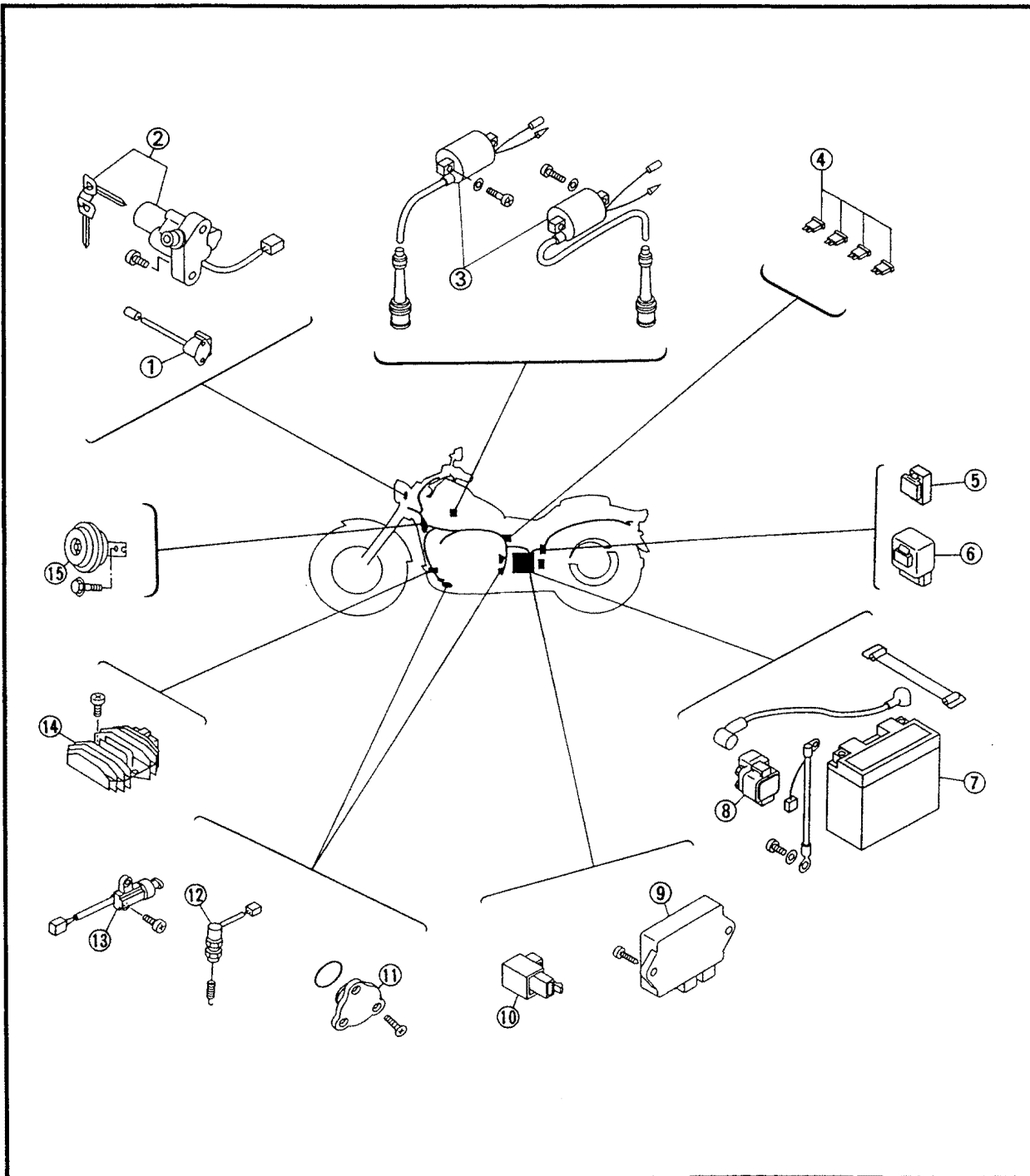

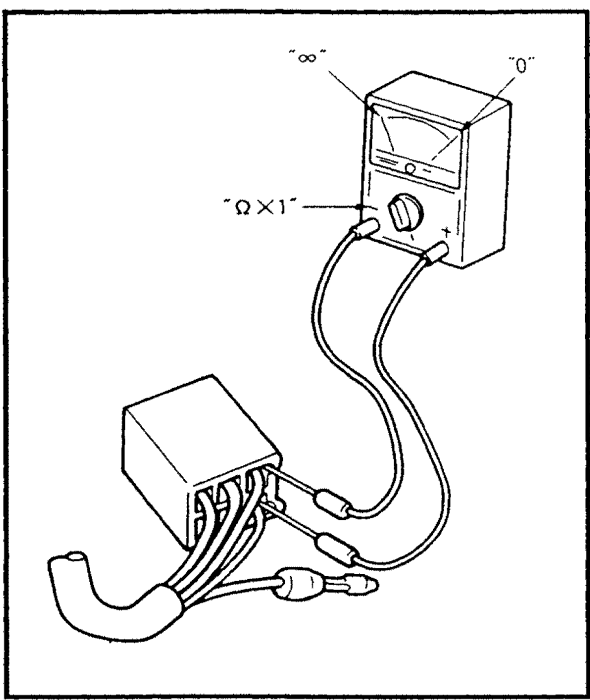

SWITCH INSPECTION

SWITCH INSPECTION

Use a pocket tester to check the terminals for continuity. If the continuity is faulty as any point, replace the switch.

	<p>Pocket tester: YU-03112, 90890-03112</p>
---	--

NOTE:

- Set the pocket tester to "0" before starting the test.
- The pocket tester should be set to the "x 1" Ω range when testing the switch for continuity.
- Turn the switch on and off a few times when checking it.

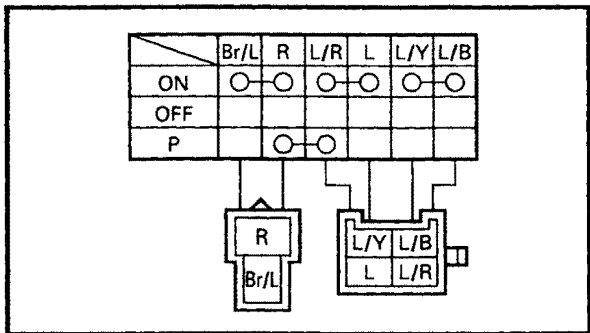

INSPECTING A SWITCH SHOWN IN THE MANUAL

The terminal connections for switches (main switch, handlebar switch, engine stop switch, light switch, etc.) are shown in a chart similar to the one on the left.

This chart shows the switch positions in the column and the switch lead colors in the top row.

For each switch position, "○—○" indicates the terminals with continuity.

The example chart shows that:

- ① There is continuity between the "Black and Black/White" leads when the switch is set to "OFF".
- ② There is continuity between the "Red and Brown" leads when the switch is set to "ON".



SWITCH CONTINUITY INSPECTION

Refer to "SWITCH INSPECTION" and check for continuity between lead terminals.

Poor connection, no continuity → Correct or replace.

* The coupler locations are circled.

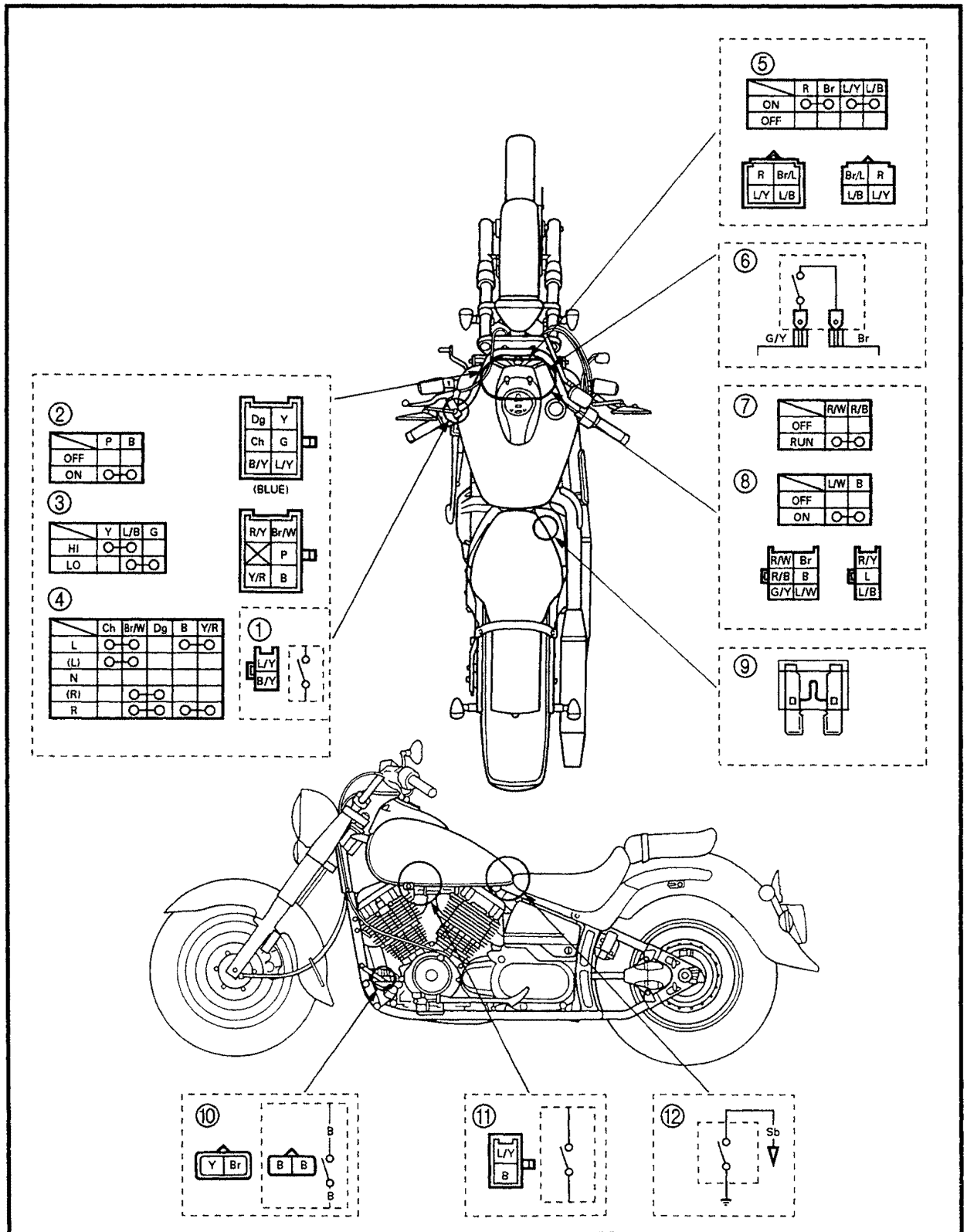

SWITCH INSPECTION

ELEC

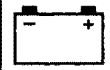

- ① Clutch switch
- ② Horn switch
- ③ Dimmer switch
- ④ Turn switch
- ⑤ Main switch
- ⑥ Front brake switch
- ⑦ Engine stop switch
- ⑧ Start switch
- ⑨ Fuse
- ⑩ Rear brake switch
- ⑪ Sidestand switch
- ⑫ Neutral switch

EB802010
TROUBLESHOOTING

IF THE IGNITION SYSTEM FAILS TO OPERATE (NO SPARK OR INTERMITTENT SPARK):

Procedure

Check:

- | | |
|--|---|
| <ul style="list-style-type: none"> 1.Fuses (main and ignition) 2.Battery 3.Spark plugs 4.Ignition spark gap 5.Spark plug cap resistance 6.Ignition coil resistance 7.Pickup coil resistance | <ul style="list-style-type: none"> 8.Main switch 9.Engine stop switch 10.Neutral switch 11.Sidestand switch 12.Relay unit (diode) 13.Wiring connection (the entire ignition system) |
|--|---|

NOTE:

- Remove the following part(s) before troubleshooting:
 - 1)Battery cover
 - 2)Rider's seat
 - 3)Fuel tank
 - 4)Steering head side covers
- Use the following special tool(s) for troubleshooting.



Dynamic spark tester:
YM-34487
Ignition checker:
90890-06754
Pocket tester:
YU-03112, 90890-03112

EB802011

1.Fuses (main and ignition)
Refer to "SWITCH INSPECTION".

CONTINUITY
↓

NO CONTINUITY
↓

Replace the fuses.

EB802012

2.Battery

- Check the battery condition.
Refer to "BATTERY INSPECTION" in CHAPTER 3.

Open-circuit voltage:
12.8 V or more at 20 °C (68°F)

CORRECT
↓
*

INCORRECT
↓

- Clean the battery terminals.
- Recharge or replace the battery.



EB802013

3. Spark plugs

- Check the spark plug condition.
- Check the spark plug type.
- Check the spark plug gap.
Refer to "SPARK PLUG INSPECTION" in CHAPTER 3.

Standard spark plug:
DPR7EA-9/NGK
X22EPR-U9/DENSO

 **Spark plug gap:**
0.8 ~ 0.9 mm (0.031 ~ 0.035 in)

INCORRECT



Repair or replace the spark plugs.

 CORRECT

EB802014

4. Ignition spark gap

- Disconnect the spark plug cap from the spark plug.
- Connect the ignition checker ① as shown.
- ② Spark plug cap
- Turn the main switch to "ON".

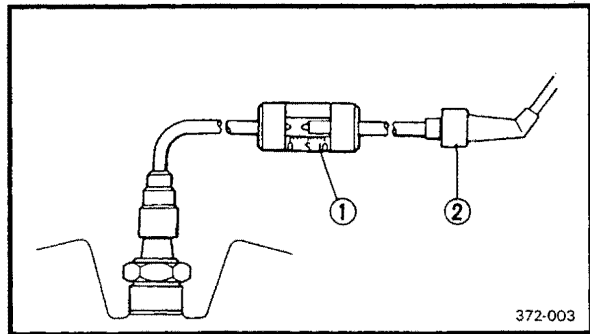



- Check the ignition spark gap ③.
- Crank the engine by pushing the starter switch, and increase the spark gap until a misfire occurs.

MEETS SPECIFICATION



The ignition system is not faulty.

 **Minimum spark gap:**
6.0 mm (0.24 in)

 OUT OF SPECIFICATION OR NO SPARK

EB802015

5. Spark plug cap resistance

- Remove the spark plug cap.
- Connect the pocket tester ($\Omega \times 1k$) to the spark plug cap.

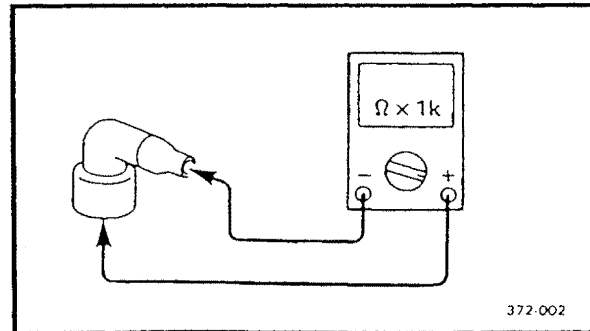

IGNITION SYSTEM

ELEC



- Check if the spark plug cap has the specified resistance.



Spark plug cap resistance:
10 k Ω at 20 °C (68°F)

MEETS SPECIFICATION

OUT OF SPECIFICATION

Replace the spark plug cap.

EB802016

6. Ignition coil resistance

- Disconnect the ignition coil connector from the wire harness.
- Connect the pocket tester ($\Omega \times 1$) to the ignition coil.

Tester (+) lead → Red/Black terminal
Tester (-) lead → Orange (Gray) terminal

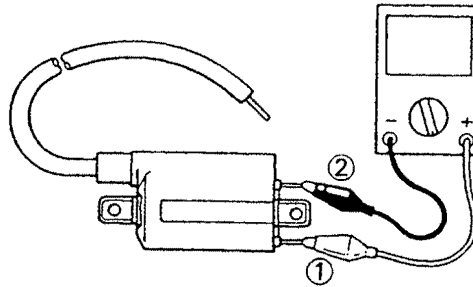

373-020

- Check if the primary coil has the specified resistance.



Primary coil resistance:
3.8 ~ 4.6 Ω at 20 °C (68°F)

- Connect the pocket tester ($\Omega \times 1k$) to the ignition coil.

Tester (+) lead → spark plug lead ①
Tester (-) lead → Red/Black terminal ②

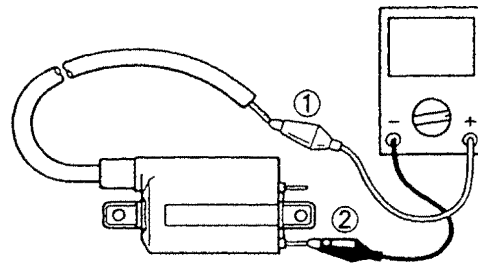

373-021

- Check if the secondary coil has the specified resistance.



Secondary coil resistance:
10.1 ~ 15.1 k Ω at 20 °C (68°F)

BOTH MEET SPECIFICATION
*

OUT OF SPECIFICATION

Replace the ignition coil.



EB80201C

7.Pickup coil resistance

- Disconnect the pickup coil coupler from the wire harness.
- Connect the pocket tester ($\Omega \times 100$) to the pickup coil terminal.

Tester (+) lead → **Gray terminal** ①
Tester (-) lead → **Black terminal** ②

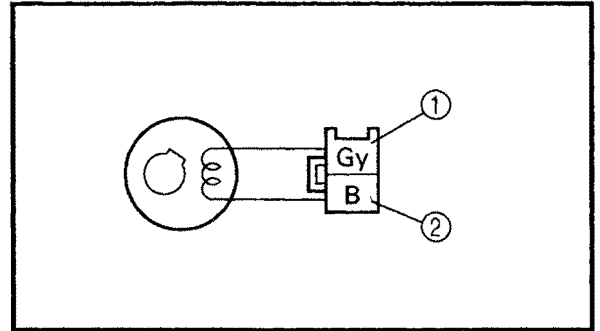

- Check if the pickup coil has the specified resistance.

Pickup coil resistance:
 182 ~ 222 Ω at 20 °C (68°F)
 (Gray — Black)

OUT OF SPECIFICATION



Replace the pickup coil.

MEETS SPECIFICATION

8.Main switch
 Refer to "SWITCH INSPECTION".

INCORRECT



Replace main switch.

CORRECT

9.Engine stop switch
 Refer to "SWITCH INSPECTION".

INCORRECT



Replace handlebar switch (right).

CORRECT

10.Neutral switch
 Refer to "SWITCH INSPECTION".

INCORRECT



Replace neutral switch.

CORRECT

11.Sidestand switch
 Refer to "SWITCH INSPECTION".

INCORRECT



Replace sidestand switch.

CORRECT

*



12. Relay unit (diode)

- Remove the relay unit from the wire harness.
- Check for continuity as follows:
Sky blue – Blue/Yellow ②

Tester (+) lead → Sky blue ①	Continuity
Tester (-) lead → Blue/Yellow ②	
Tester (+) lead → Blue/Yellow ②	No Continuity
Tester (-) lead → Sky blue ①	

NOTE: _____
When you switch the “-” and “+” leads of the digital pocket tester the readings in the above chart will be reversed.

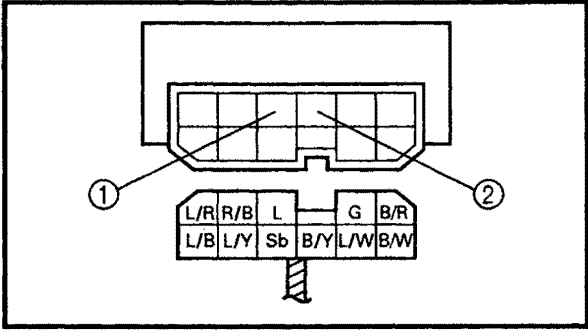

INCORRECT



Replace the relay unit.

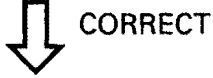

EB80201D

13. Wiring connection

- Check the connections of the entire ignition system.
Refer to “CIRCUIT DIAGRAM”.

POOR CONNECTION



Properly connect the ignition system.

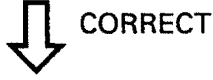

Replace the ignitor unit.

ELECTRIC STARTING SYSTEM

ELEC



EB80300 ELECTRIC STARTING SYSTEM CIRCUIT DIAGRAM

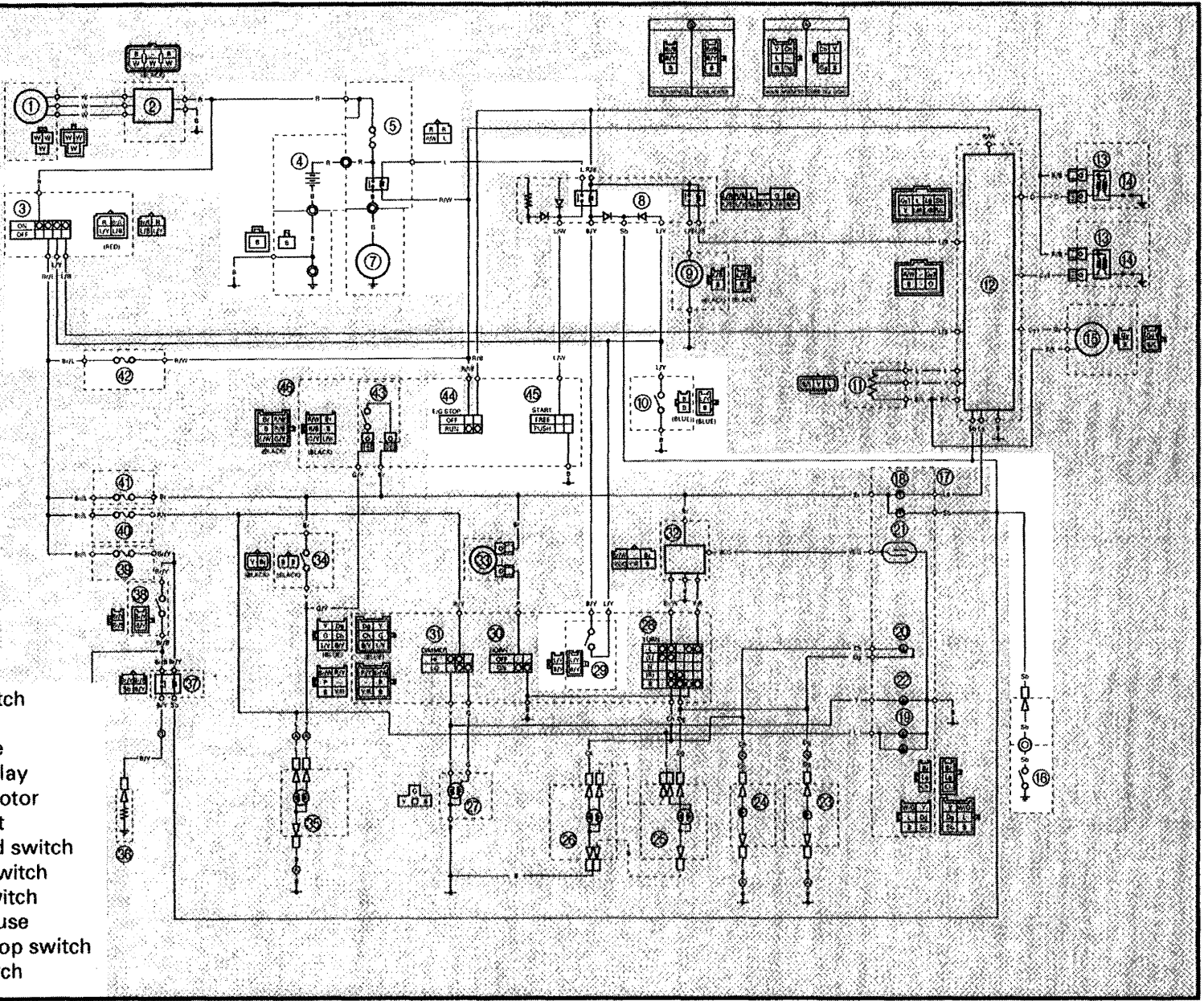

- ③ Main switch
- ④ Battery
- ⑤ Main fuse
- ⑥ Starter relay
- ⑦ Starter motor
- ⑧ Relay unit
- ⑩ Sidestand switch
- ⑬ Neutral switch
- ⑳ Clutch switch
- ㉒ Ignition fuse
- ㉔ Engine stop switch
- ㉕ Start switch

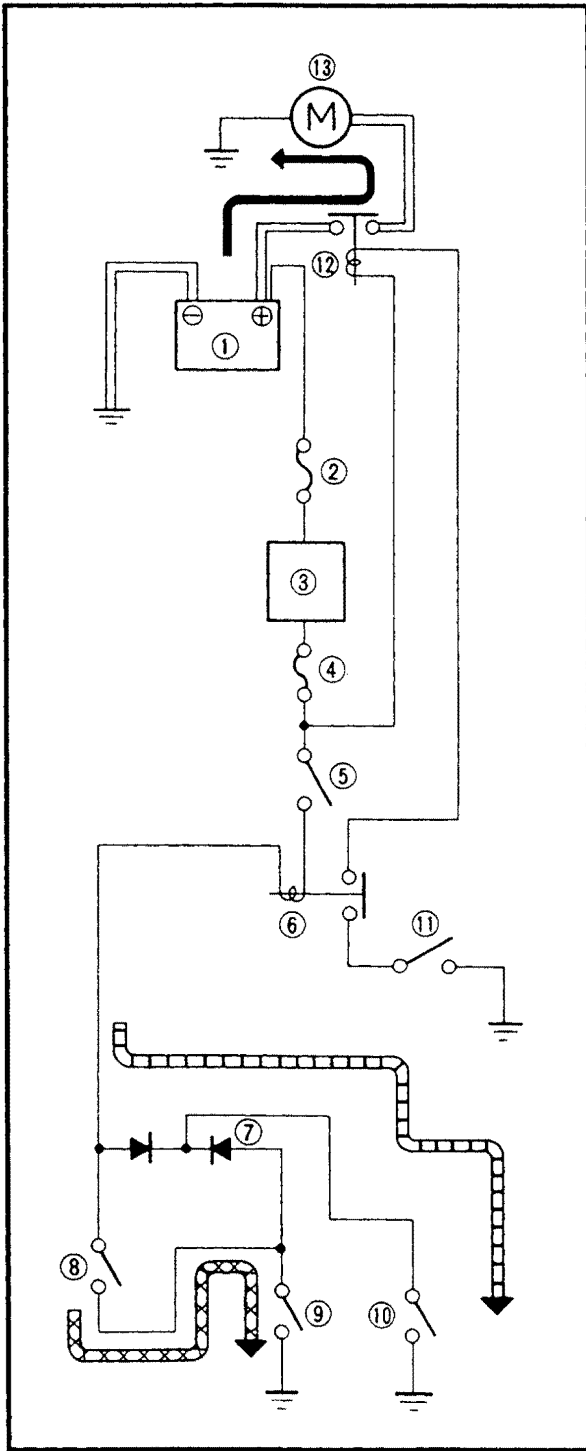

EB803010

STARTING CIRCUIT OPERATION

The starting circuit on this model consists of the starter motor, starter relay, and the starting circuit cut-off relay. If the engine stop switch is on "RUN" and the main switch is on "ON" (both switches are closed), the starter motor can operate only if:

- The transmission is in neutral (the neutral switch is closed).

or if

- The clutch lever is pulled to the handlebar (the clutch switch is closed) and the sidestand is up (the sidestand switch is closed).

The starting circuit cut-off relay prevents the starter from operating when neither of these conditions have been met. In this instance, the starting circuit cut-off relay is open so current cannot reach the starter motor.

When at least one of the above conditions have been met however, the starting circuit cut-off relay is closed, and the engine can be started by pressing the starter switch.

WHEN THE TRANSMISSION IS IN NEUTRAL

WHEN THE SIDESTAND IS UP AND THE CLUTCH LEVER IS PULLED IN

- ① Battery
- ② Main fuse
- ③ Main switch
- ④ Ignition fuse
- ⑤ Engine stop switch
- ⑥ Starting circuit cut-off relay
- ⑦ Diode
- ⑧ Clutch switch
- ⑨ Sidestand switch
- ⑩ Neutral switch
- ⑪ Start switch
- ⑫ Starter relay
- ⑬ Starter motor

EB803020
TROUBLESHOOTING

IF THE STARTER MOTOR FAILS TO OPERATE:

Procedure

Check:

- | | |
|--|---|
| <ol style="list-style-type: none"> 1.Fuses (main and ignition) 2.Battery 3.Starter motor 4.Relay unit (starting circuit cut-off relay) 5.Relay unit (diode) 6.Starter relay 7.Main switch | <ol style="list-style-type: none"> 8.Engine stop switch 9.Neutral switch 10.Sidestand switch 11.Clutch switch 12.Start switch 13.Wiring connection (the entire starting system) |
|--|---|

NOTE:

- Remove the following part(s) before troubleshooting:
 - 1)Battery cover
 - 2)Rider's seat
 - 3)Fuel tank
 - 4)Steering head side covers
- Use the following special tool(s) for troubleshooting.



Pocket tester:
YU-03112, 90890-03112

EB802011

1.Fuses (main and ignition)

Refer to "SWITCH INSPECTION".

↓ CONTINUITY

NO CONTINUITY ↓

Replace the fuse(s).

EB802012

2.Battery

• Check the battery condition.
Refer to "BATTERY INSPECTION" in CHAPTER 3.

Open-circuit voltage:
12.8 V or more at 20 °C (68°F)

↓ CORRECT
*

INCORRECT ↓

- Clean the battery terminals.
- Recharge or replace the battery.

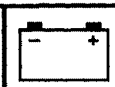

EB803021

3. Starter motor

- Connect the battery positive terminal ① and starter motor cable ② using a jumper lead ③*.
- Check the operation of the starter motor.

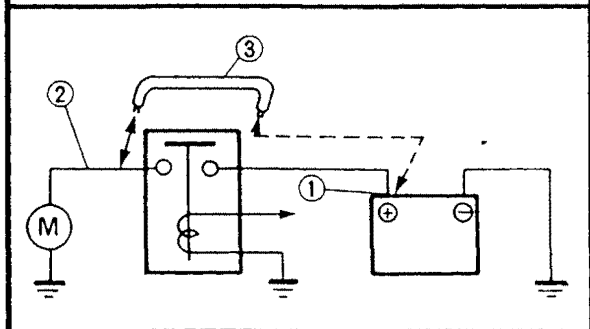

EB803023

4. Relay unit (starting circuit cut-off relay)

- Remove the relay unit from the wire harness.
- Connect the pocket tester ($\Omega \times 1$) and battery (12 V) to the relay unit terminals.

Battery (+) terminal → Red/Black terminal ①
Battery (-) terminal → Black/Yellow terminal ②

Tester (+) lead → Blue terminal ③
Tester (-) lead → Blue/White terminal ④

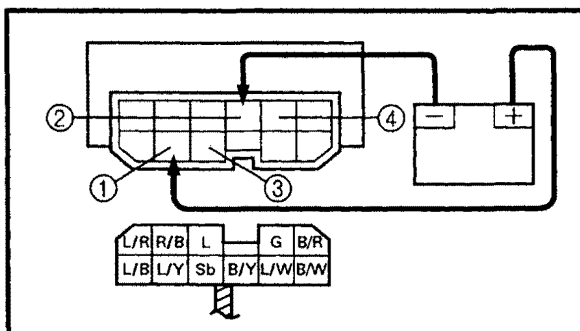

NO CONTINUITY



Replace the relay unit.

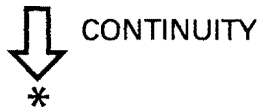

*

⚠ WARNING

- A wire that is used as a jumper lead must have the equivalent capacity or more as that of the battery lead, otherwise the jumper lead may burn.
- This check is likely to produce sparks, so be sure that no flammable gas or fluid is in the vicinity.

DOES NOT MOVE

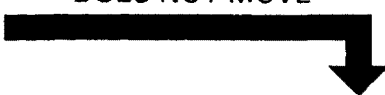

Repair or replace the starter motor.

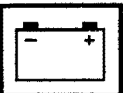

5. Relay unit (diode)

- Remove the relay unit from the wire harness.
- Check for continuity as follows:
 Sky blue ① – Black/Yellow ②
 Sky blue ① – Blue/Yellow ③

Tester (+) lead → Sky blue ①	Continuity
Tester (-) lead → Black/Yellow ②	
Tester (+) lead → Black/Yellow ②	No Continuity
Tester (-) lead → Sky blue ①	
Tester (+) lead → Sky blue ①	Continuity
Tester (-) lead → Blue/Yellow ③	
Tester (+) lead → Blue/Yellow ③	No Continuity
Tester (-) lead → Sky blue ①	

NOTE: _____
 When you switch the “-” and “+” leads of the digital pocket tester the readings in the above chart will be reversed.

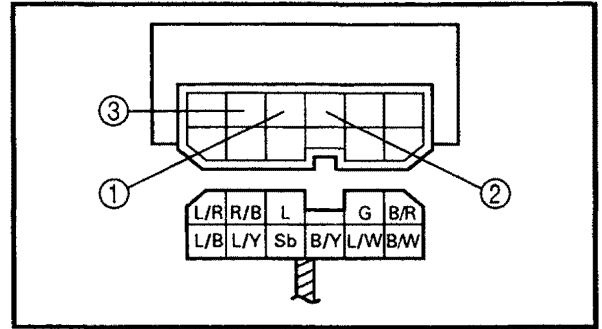

INCORRECT



Replace the relay unit.

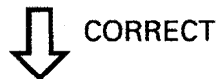

EB803024

6. Starter relay

- Remove the starter relay from the wire harness.
- Connect the pocket tester ($\Omega \times 1$) and battery (12 V) to the starter relay terminals.

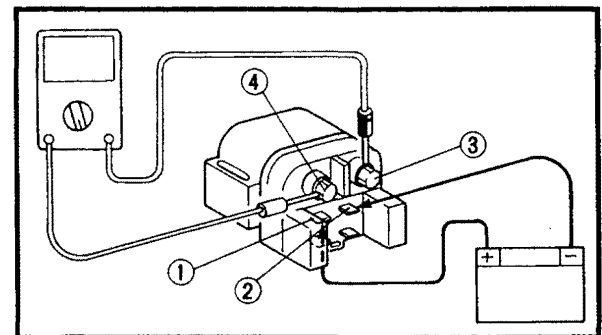

NO CONTINUITY



Replace the starter relay.

Battery (+) terminal → Red/White terminal ①
Battery (-) terminal → Blue terminal ②
Tester (+) lead → Red terminal ③
Tester (-) lead → Black terminal ④

- Check the starter relay for continuity.

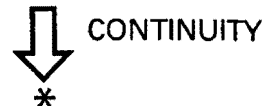



7. Main switch
Refer to "SWITCH INSPECTION".

INCORRECT



Replace main switch.



CORRECT

8. Engine stop switch
Refer to "SWITCH INSPECTION".

INCORRECT



Replace handlebar switch (right).



CORRECT

9. Neutral switch
Refer to "SWITCH INSPECTION".

INCORRECT



Replace neutral switch.



CORRECT

10. Sidestand switch
Refer to "SWITCH INSPECTION".

INCORRECT



Replace sidestand switch.



CORRECT

11. Clutch switch
Refer to "SWITCH INSPECTION".

INCORRECT



Replace clutch switch.



CORRECT

12. Start switch
Refer to "SWITCH INSPECTION".

INCORRECT



Replace handlebar switch (right).



CORRECT

EB803028
13. Wiring connection
• Check the connections of the entire starting system.
Refer to "CIRCUIT DIAGRAM".

POOR CONNECTION



Properly connect the starting system.



STARTER MOTOR

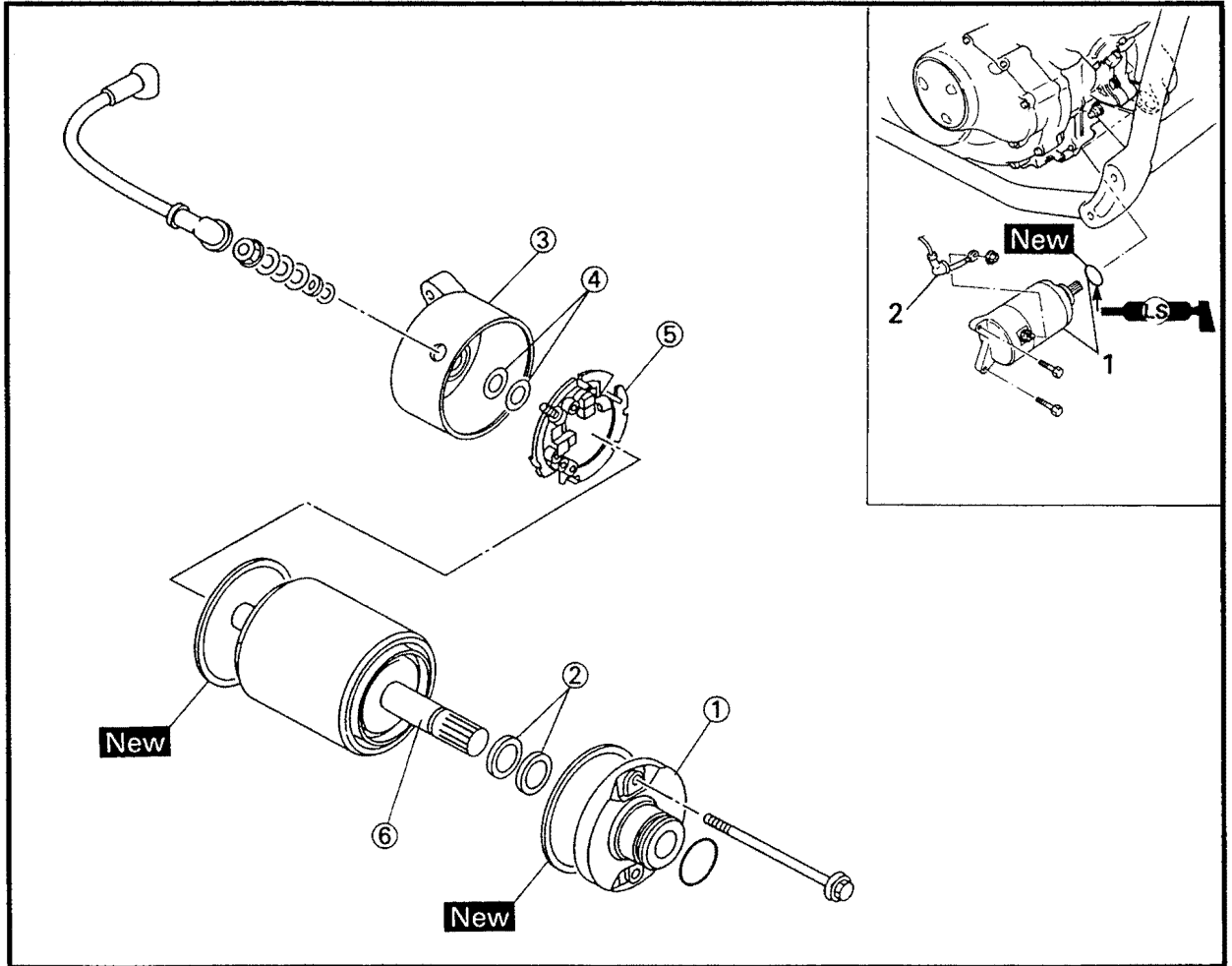

Order	Job name/Part name	Q'ty	Remarks
	Starter motor removal Exhaust pipe assembly		Remove the parts in the order below. Refer to "ENGINE ASSEMBLY" in CHAPTER 4.
1	Starter motor/O-ring	1/1	
2	Starter motor lead	1	
	Starter motor disassembly		Disassemble the parts in the order below.
①	Front bracket	1	Refer to "STARTER MOTOR ASSEMBLY".
②	Washer kit	1	
③	Rear bracket	2	
④	Shims	1	
⑤	Brush seat/Brush 1	1/1	
⑥	Armature coil	1	<p>NOTE: _____ Be sure to remove the installation nut on brush #1 first.</p> <p>_____</p> <p>For assembly, reverse the disassembly procedure.</p>

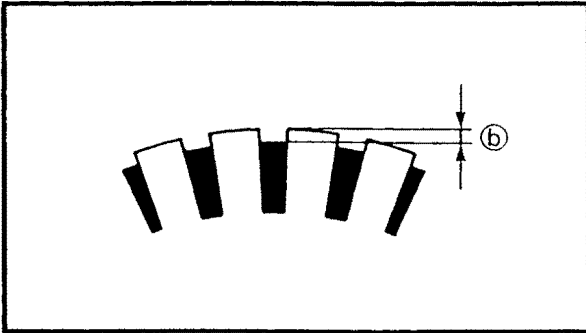
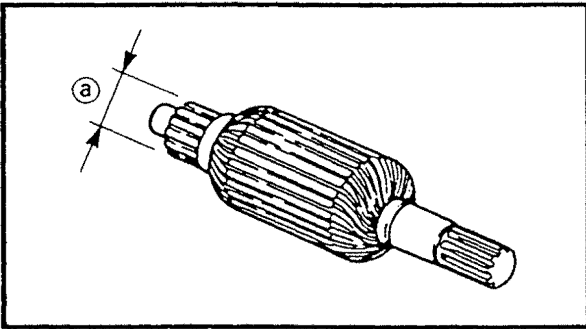

EB803034

STARTER MOTOR INSPECTION

1. Inspect:

- Commutator
Dirty → Clean it with #600 grit sandpaper.

2. Measure:

- Commutator diameter (a)
Out of specification → Replace the starter motor.



Commutator wear limit:
27 mm (1.06 in)

3. Measure:

- Mica undercut (b)
Out of specification → Scrape the mica to the proper measurement using a hacksaw blade which has been grounded to fit the commutator.



Mica undercut:
0.7 mm (0.03 in)

NOTE:

The mica insulation of the commutator must be undercut to ensure proper operation of the commutator.

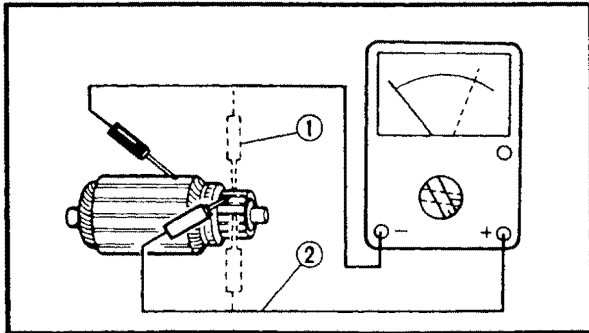

4. Inspect:

- Armature coil resistances (insulation/continuity)
Defects → Replace the starter motor.

Inspection steps:

- Connect the pocket tester for the continuity ① and insulation ② checks.
- Measure the armature coil resistances.



Armature coil continuity resistance ①:
0 Ω at 20°C (68°F)
Armature coil insulation resistance ②:
More than 1 MΩ at 20°C (68°F)

- If the resistance is incorrect, replace the starter motor.

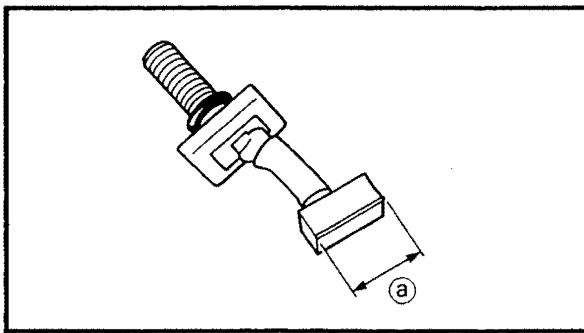

5.Measure:

- Brush length ①
Out of specification → Replace.

	Brush length wear limit: 4 mm (0.16 in)
--	---

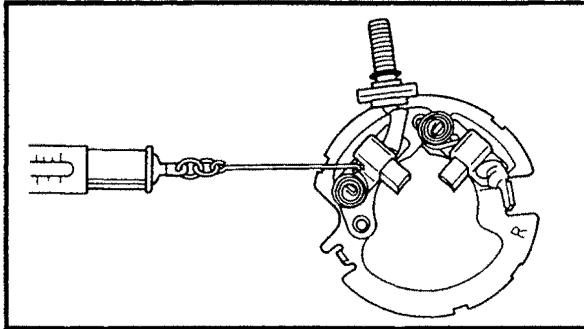

6.Measure:

- Brush spring force
Fatigue/out of specification → Replace as a set.

	Brush spring force: 520 ~ 920 g (18.4 ~ 32.5 oz)
--	--

7.Inspect:

- Bearing
Roughness → Replace.
- Oil seal
- Bushing
Wear/damage → Replace.

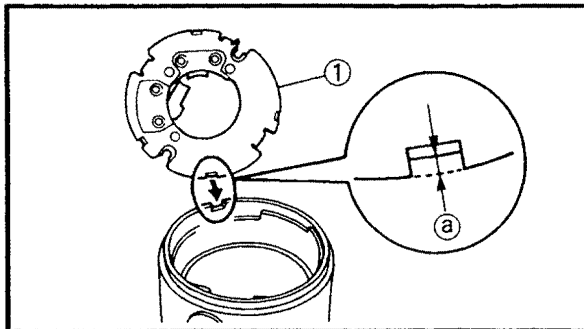

EB803036

STARTER MOTOR ASSEMBLY

Reverse the "Removal" procedure.

Note the following points.

1.Install:

- Brush seat ①

NOTE: _____

Align the projection ① on the brush seat with the slot on the housing.

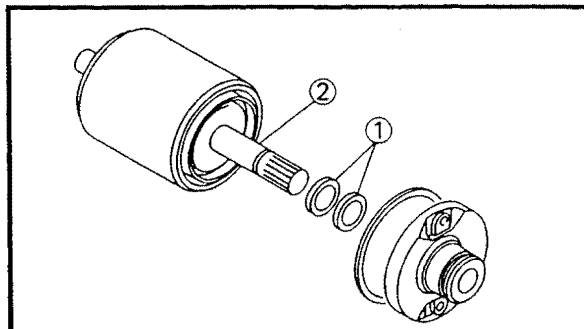

2.Install:

- Shims ①
- Armature coil ②

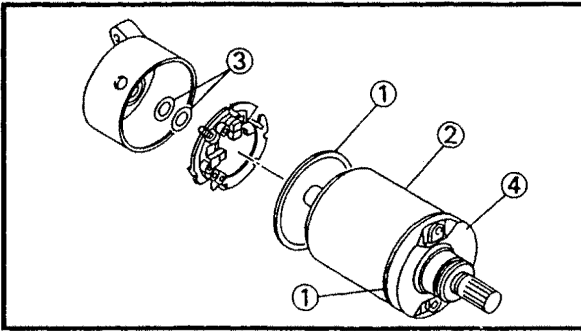

3. Install:

- Gasket ①
- Yoke ②
- Washer kit ③
- Brackets ④

NOTE:

Align the match marks (a) on the yoke with the match marks (b) on the brackets.

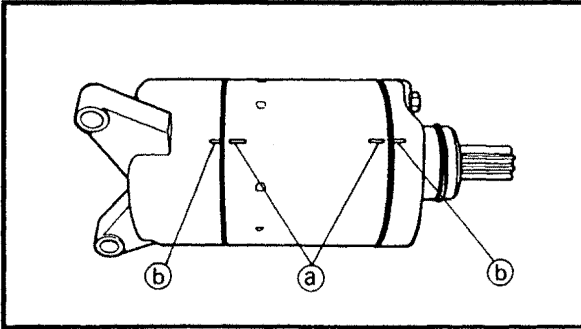

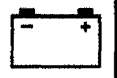

EB904000
CHARGING SYSTEM
CIRCUIT DIAGRAM

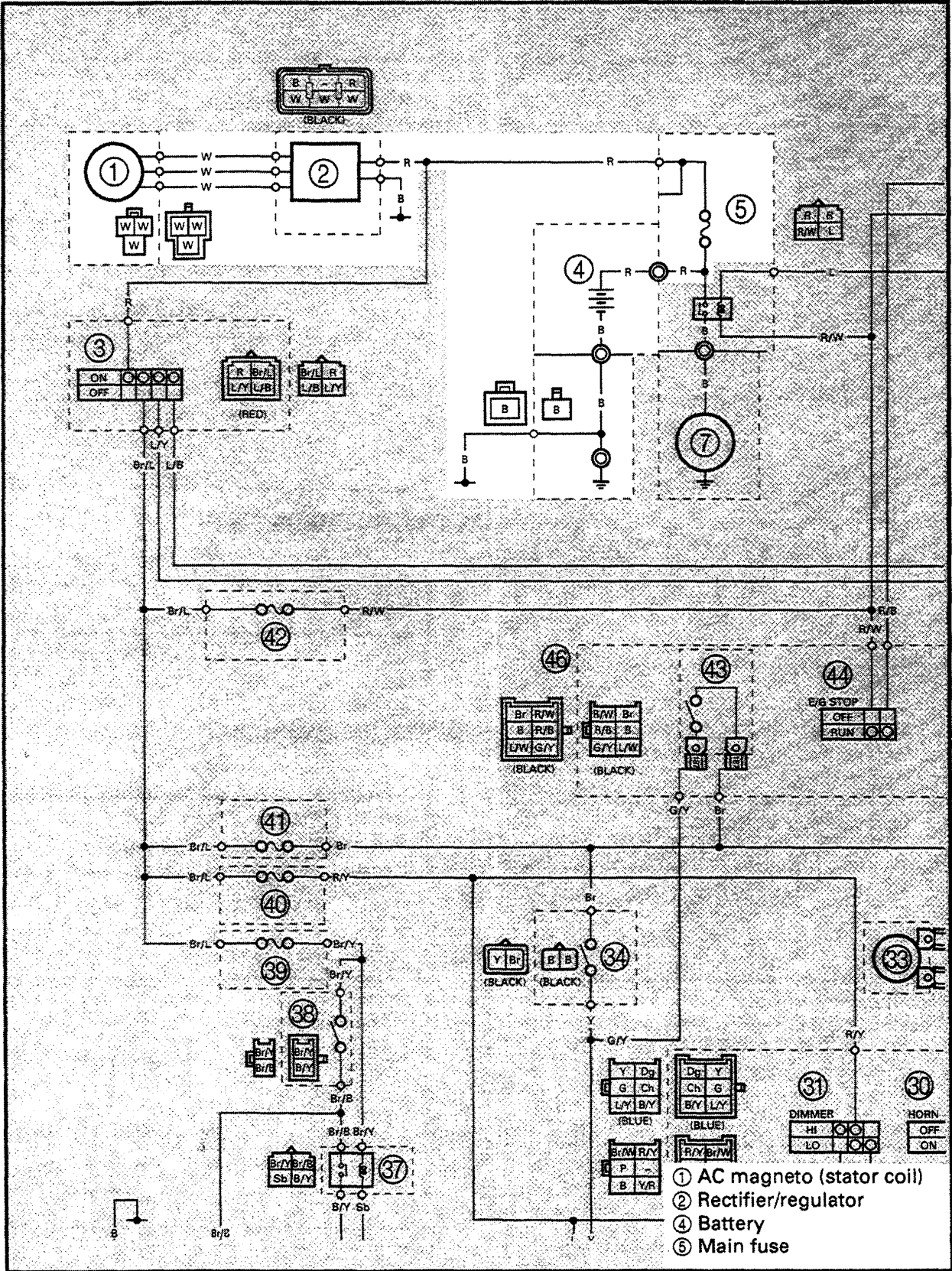

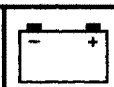

EB804010
TROUBLESHOOTING

IF THE BATTERY IS NOT CHARGED:

Procedure

Check:

- 1. Fuse (main)
- 2. Battery
- 3. Charging voltage
- 4. Stator coil resistance
- 5. Wiring connections (the entire charging system)

NOTE:

- Remove the following part(s) before troubleshooting:
 - 1) Battery cover
 - 2) Rider's seat
- Use the following special tool(s) for troubleshooting.



Engine tachometer:
YU-08036-A, 90890-03113
Pocket tester:
YU-03112, 90890-03112

EB802011

1. Fuses (main)
Refer to "SWITCH INSPECTION".



CONTINUITY

NO CONTINUITY



Replace the fuses.

EB802012

2. Battery

- Check the battery condition. Refer to "BATTERY INSPECTION" in CHAPTER 3.

Open-circuit voltage:
12.8 V or more at 20°C (68°F)



CORRECT

INCORRECT

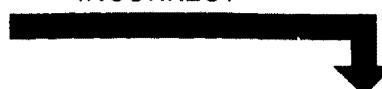

- Clean the battery terminals.
- Recharge or replace the battery.

EB804011

3. Charging voltage

- Connect the engine tachometer to the spark plug lead #1.
- Connect the pocket tester (DC 20 V) to the battery.

Tester (+) lead → Battery (+) terminal
Tester (-) lead → Battery (-) terminal

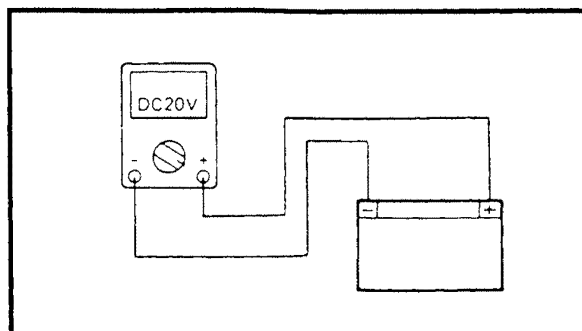

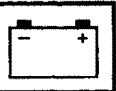

- Start the engine and accelerate to about 5,000 r/min.

Charging voltage:
14 V at 5,000 r/min

NOTE:
Use a fully charged battery.

MEETS SPECIFICATION

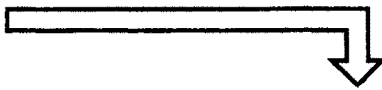

The charging circuit is not faulty.

OUT OF SPECIFICATION

EB804012

4. Stator coil resistance

- Disconnect the AC magneto coupler from the wire harness.
- Connect the pocket tester ($\Omega \times 1$) to the stator coils.

Tester (+) lead → White terminal ①
Tester (-) lead → White terminal ②

Tester (+) lead → White terminal ①
Tester (-) lead → White terminal ③

- Measure the stator coil resistance.

Stator coil resistance:
0.50 ~ 0.62 Ω at 20°C (68°F)

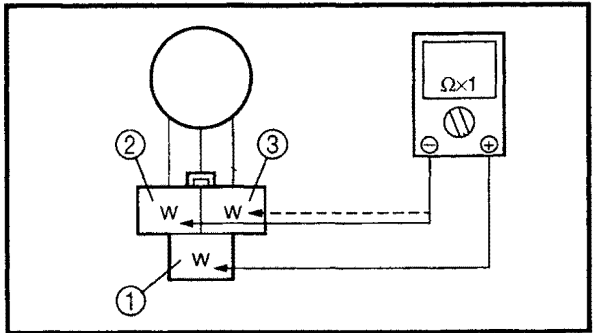

OUT OF SPECIFICATION



Replace the stator coil assembly.

BOTH MEET SPECIFICATION

EB804015

5. Wiring connections

- Check the connections of the entire charging system. Refer to "CIRCUIT DIAGRAM".

POOR CONNECTION



Properly connect the charging system.

CORRECT

Replace the rectifier/regulator.

EB805000
LIGHTING SYSTEM
CIRCUIT DIAGRAM

- ③ Main switch
- ④ Battery
- ⑤ Main fuse
- ⑯ Meter light
- ⑰ High beam indicator light
- ⑱ Headlight
- ⑲ Dimmer switch
- ⑳ Tail/brake light
- ㉑ Headlight fuse

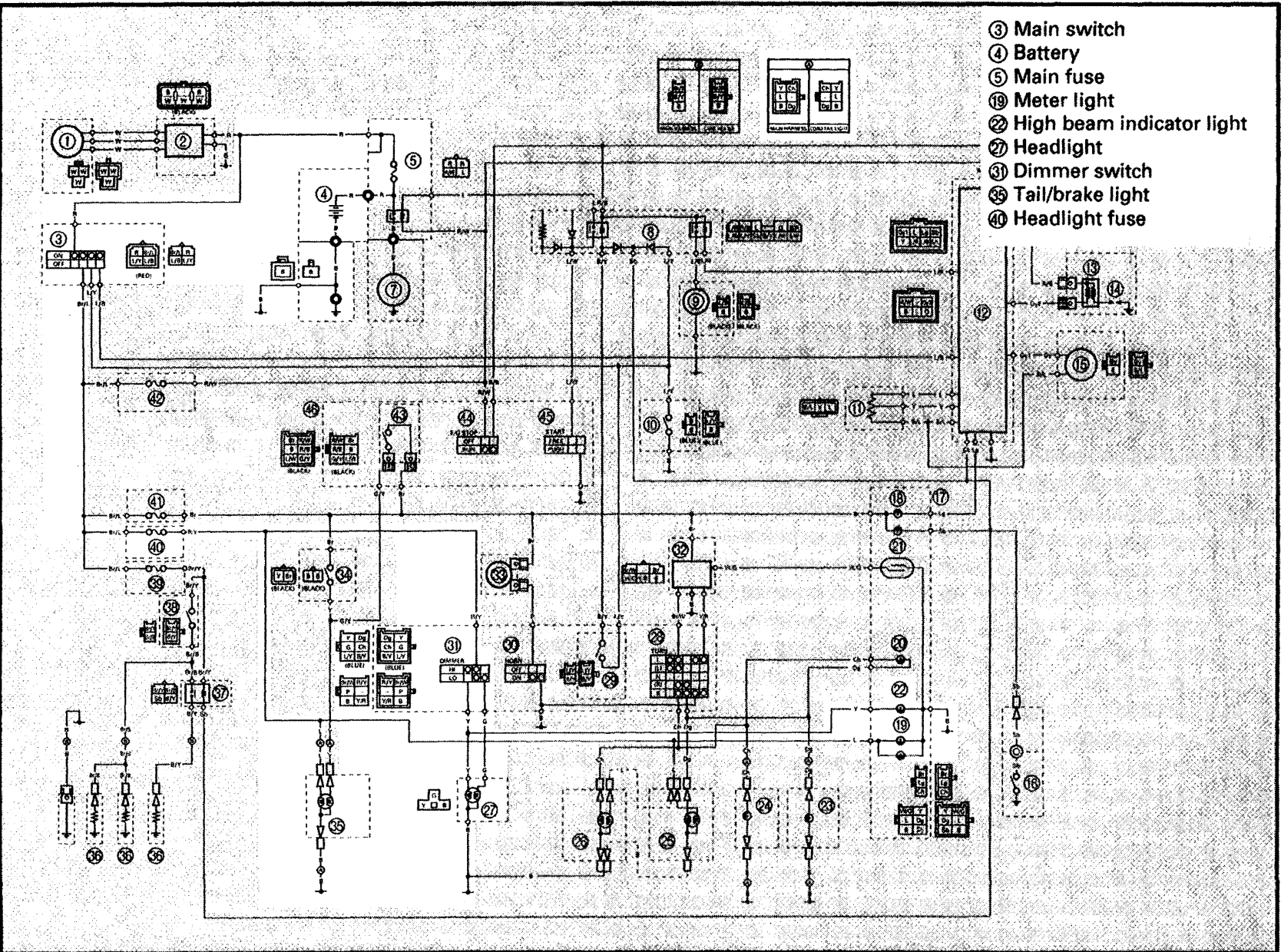



EB805010

TROUBLESHOOTING

IF THE HEADLIGHT, HIGH BEAM INDICATOR LIGHTS, TAIL/BRAKE LIGHT, AUXILIARY LIGHT AND/OR METER LIGHT FAIL TO COME ON:

Procedure

Check:

- 1.Fuses (main and head light)
- 2.Battery
- 3.Main switch
- 4.Dimmer switch
- 5.Wiring connections
(the entire lighting system)

NOTE:

- Remove the following part(s) before troubleshooting:
 - 1)Battery cover
 - 2)Rider's seat
 - 3)Fuel tank
 - 4)Steering head side covers
 - 5)Headlight lens unit
 - 6)Tail/brake light unit
- Use the following special tool(s) for troubleshooting.



Pocket tester:
YU-03112, 90890-03112

EB802011

1.Fuses (main and head light)
Refer to "SWITCH INSPECTION".

↓ CONTINUITY

NO CONTINUITY

Replace the fuses.

EB802012

2.Battery

- Check the battery condition. Refer to "BATTERY INSPECTION" in CHAPTER 3.

Open-circuit voltage:
12.8 V or more at 20°C (68°F)

↓ CORRECT
*

INCORRECT

- Clean the battery terminals.
- Recharge or replace the battery.



3. Main switch
Refer to "SWITCH INSPECTION".

INCORRECT



Replace main switch.

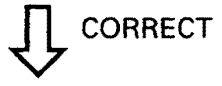

4. Dimmer switch
Refer to "SWITCH INSPECTION".

INCORRECT



Dimmer switch is faulty, replace handle-bar switch (left).

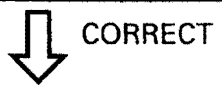

EB805013

5. Wiring connection
• Check the connections of the entire lighting system.
Refer to "WIRING DIAGRAM".

POOR CONNECTION



Properly connect the lighting system.

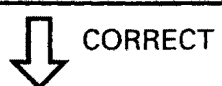

Check the condition of each of the lighting system's circuits.
Refer to "LIGHTING SYSTEM CHECK".

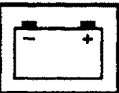

EB805020

LIGHTING SYSTEM CHECK

1.If the headlight and the high beam indicator light fail to come on:

1.Bulb and bulb socket

- Check the bulb and bulb socket for continuity.

CONTINUITY

NO CONTINUITY

Replace the bulb and/or bulb socket.

2.Voltage

- Connect the pocket tester (DC 20 V) to the headlight and high beam indicator light couplers.

- A** When the dimmer switch is on "LO".
- B** When the dimmer switch is on "HI".

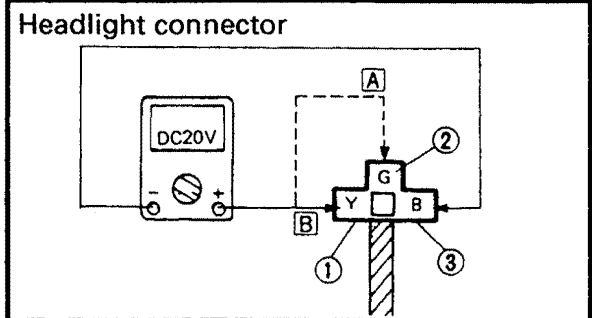

Headlight:
 Tester (+) lead → Yellow terminal ① or Green terminal ②
 Tester (-) lead → Black terminal ③
High beam indicator light:
 Tester (+) lead → Yellow terminal ④
 Tester (-) lead → Black terminal ⑤

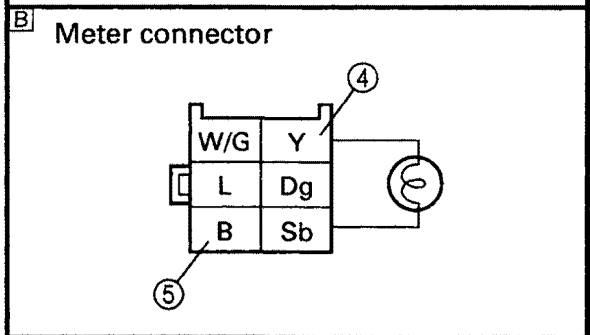

- Turn the main switch to "ON".
- Turn the dimmer switch to "LO" or "HI".
- Check the voltage (12 V) of the "Green" and "Yellow" leads on the bulb socket connector.

MEETS SPECIFICATION

OUT OF SPECIFICATION

The wiring circuit from the main switch to the bulb socket connector is faulty, repair it.

This circuit is not faulty.

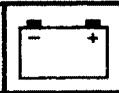

EB805021

2.If the meter light fails to come on:

1.Bulb and bulb socket
 • Check the bulb and bulb socket for continuity.

CONTINUITY

2.Voltage
 • Connect the pocket tester (20 V) to the bulb socket coupler.
Tester (+) lead → Blue terminal ①
Tester (-) lead → Black terminal ②

NO CONTINUITY

Replace the bulb and/or bulb socket.

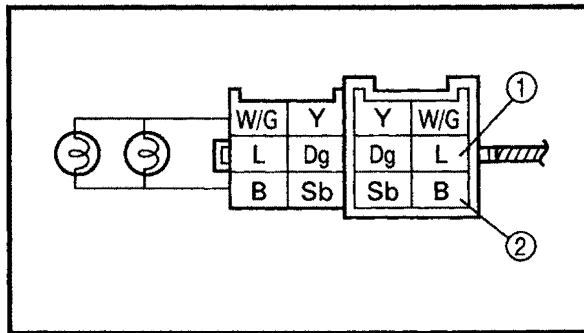

• Turn the main switch to "ON".
 • Check the voltage (12 V) of the "blue" lead on the bulb socket connector.

MEETS SPECIFICATION

This circuit is not faulty.

OUT OF SPECIFICATION

The wiring circuit from the main switch to the bulb socket connector is faulty, repair it.

EB805022

3.If the taillight fails to come on:

1.Bulb and bulb socket
 • Check the bulb and bulb socket for continuity.

CONTINUITY

2.Voltage
 • Connect the pocket tester (DC 20 V) to the bulb socket connector.
Tester (+) lead → Blue terminal ①
Tester (-) lead → Black terminal ②

NO CONTINUITY

Replace the bulb and/or bulb socket.

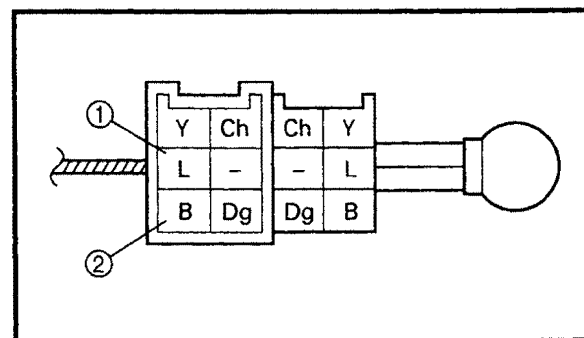

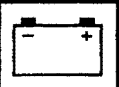

- Turn the main switch to "ON".
- Check the voltage (12 V) of the "blue" lead on the bulb socket connector.



MEETS SPECIFICATION

This circuit is not faulty.

OUT OF SPECIFICATION



The wiring circuit from the main switch to the bulb socket connector is faulty, repair it.

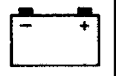

- ③ Main switch
- ④ Battery
- ⑤ Main fuse
- ⑫ Ignitor unit
- ⑯ Neutral switch
- ⑰ Engine warning light
- ⑰ Neutral ignitor light
- ⑲ High beam indicator light
- ⑲ Rear turn signal (R)
- ⑳ Rear turn signal (L)
- ㉑ Front turn signal (R)
- ㉒ Front turn signal (L)
- ㉓ Turn switch
- ㉔ Horn switch
- ㉕ Flasher relay
- ㉖ Horn
- ㉗ Rear brake switch
- ㉘ Tail/brake light
- ㉙ Front brake switch
- ㉚ Right handlebar switch

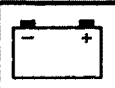

EB806010

TROUBLESHOOTING

**IF THE TURN SIGNAL, BRAKE LIGHT AND/OR INDICATOR LIGHT FAIL TO COME ON:
IF THE HORN FAILS TO SOUND:**

Procedure

Check:

1. Fuses (main and signals)
2. Battery
3. Main switch
4. Wiring connections (the entire signal system)

NOTE:

- Remove the following part(s) before troubleshooting:
 - 1) Battery cover
 - 2) Rider's seat
 - 3) Fuel tank
 - 4) Steering head side covers
 - 5) Headlight lens unit
 - 6) Tail/brake light unit
- Use the following special tool(s) for troubleshooting.



**Pocket tester:
YU-03112, 90890-03112**

EB802011

1. Fuses (main and signals)
Refer to "SWITCH INSPECTION".

NO CONTINUITY

CONTINUITY

Replace the fuse(s).

EB802012

2. Battery
• Check the battery condition.
Refer to "BATTERY INSPECTION" in CHAPTER 3.

INCORRECT

**Open-circuit voltage:
12.8 V or more at 20°C (68°F)**

- Clean the battery terminals.
- Recharge or replace the battery.

CORRECT
*

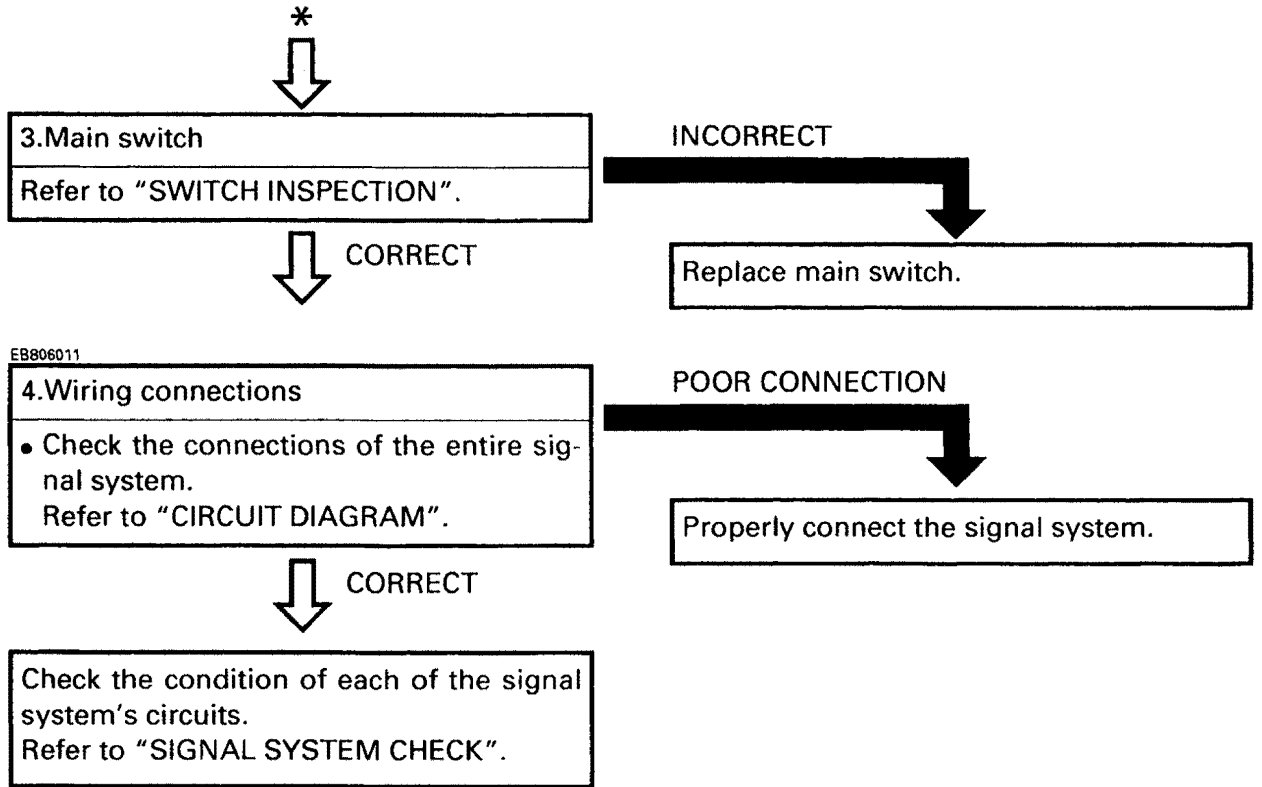
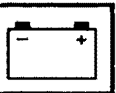

EB806020

SIGNAL SYSTEM CHECK

1.If the horn fails to sound:

1.Horn switch
Refer to "SWITCH INSPECTION".

CONTINUITY

2.Voltage
• Connect the pocket tester (DC 20 V) to the horn lead.
Tester (+) lead → Brown ①
Tester (-) lead → Frame ground

NO CONTINUITY

Replace the handlebar switch (left).

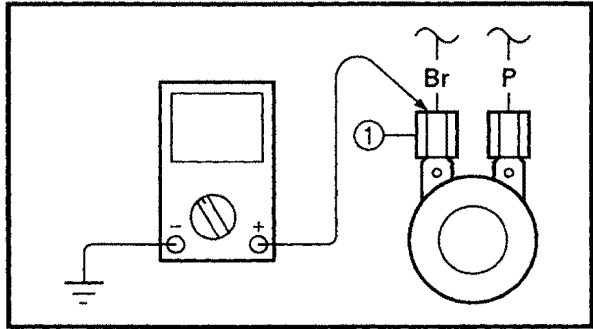

• Turn the main switch to "ON".
• Check the voltage (12 V) of the "Black/White" lead at the horn terminal.

MEETS SPECIFICATION

OUT OF SPECIFICATION

The wiring circuit from the main switch to the horn terminal is faulty, repair it.

3.Voltage
• Connect the pocket tester (DC 20 V) to the horn at the "Pink" terminal.
Tester (+) lead → Pink lead ①
Tester (-) lead → Frame ground

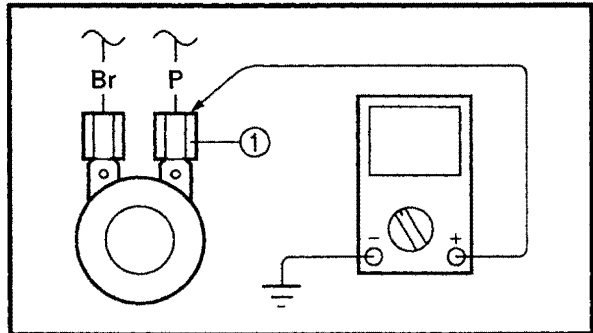

• Turn the main switch to "ON".
• Check the voltage (12 V) of the "Pink" lead at the horn terminal.

MEETS SPECIFICATION

OUT OF SPECIFICATION

Replace the horn.

Adjust or replace the horn.

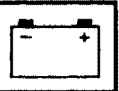

EB806022

2.If the brake light fails to come on:

1.Brake switch (front, rear)
Refer to "SWITCH INSPECTION".

↓ CORRECT

INCORRECT

Replace brake switch.

2.Voltage

- Connect the pocket tester (DC 20 V) to the bulb socket connector.

Tester (+) lead → Yellow terminal ①
Tester (-) lead → Black terminal ②

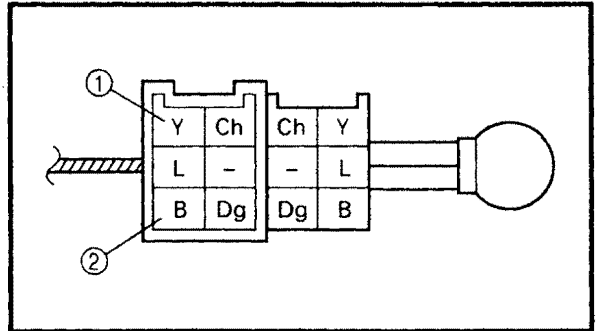

- Turn the main switch to "ON".
- The brake lever is pulled in or the brake pedal is pressed down.
- Check the voltage (12 V) of the "Yellow" lead on the bulb socket connector.

↓ MEETS SPECIFICATION

OUT OF SPECIFICATION

The wiring circuit from the main switch to the bulb socket connector is faulty, repair it.

This circuit is not faulty.

EB806023

3.If the turn signal and/or turn indicator light fails to blink:

1.Turn switch
Refer to "SWITCH INSPECTION".

↓ CORRECT

INCORRECT

Replace handlebar switch (left).

2.Voltage

- Connect the pocket tester (DC 20 V) to the flasher relay coupler.

Tester (+) lead → Brown terminal ①
Tester (-) lead → Frame ground

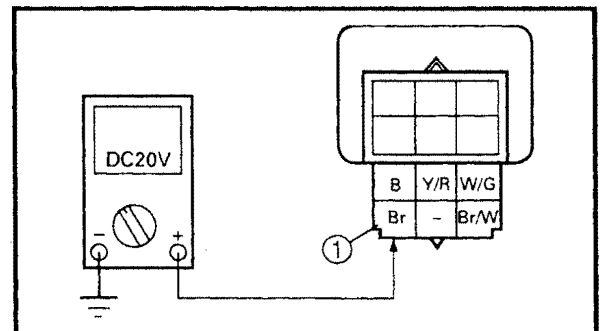

- Turn the main switch to "ON".
- Check the voltage (12 V) of the "Brown" ① lead at the flasher relay terminal.

↓ MEETS SPECIFICATION

OUT OF SPECIFICATION



The wiring circuit from the main switch to the flasher relay connector is faulty, repair it.

- 3.Voltage**
- Connect the pocket tester (DC 20 V) to the flasher relay coupler.
- Tester (+) lead → Brown/White terminal ①**
Tester (-) lead → Frame ground

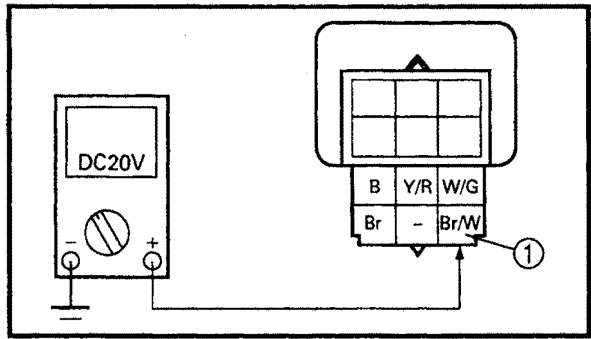

OUT OF SPECIFICATION



The flasher relay is faulty, replace it.

- Turn the main switch to "ON".
- Check the voltage (12 V) on the "Brown/White" ① lead at the flasher relay terminal.

↓ MEETS SPECIFICATION

- 4.Voltage**
- Connect the pocket tester (DC 20 V) to the bulb socket connector.
- A** Flasher light
B Turn indicator light
- At the flasher light (left):**
Tester (+) lead → Chocolate lead ①
Tester (-) lead → Frame ground
- At the flasher light (right):**
Tester (+) lead → Dark green lead ②
Tester (-) lead → Frame ground
- At turn indicator light:**
Tester (+) lead → Dark green terminal ③
Tester (-) lead → Frame ground

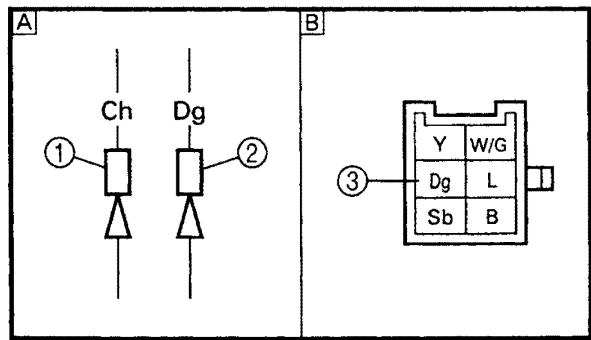

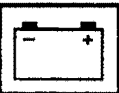

- Turn the main switch to "ON".
- Turn the turn switch to "L" or "R".
- Check the voltage (12 V) of the "Chocolate" lead or "Dark green" lead on the bulb socket connector.

↓ MEETS SPECIFICATION

This circuit is not faulty.

OUT OF SPECIFICATION

The wiring circuit from the turn switch to the bulb socket connector is faulty, repair it.

EB806024

4.If the neutral indicator light fails to come on:

1.Neutral switch
Refer to "SWITCH INSPECTION".

↓ CONTINUITY

NO CONTINUITY

Replace the neutral switch.

2.Voltage

- Connect the pocket tester (DC 20 V) to the bulb socket coupler.

Tester (+) lead → Brown terminal ①
Tester (-) lead → Sky/blue ground ②

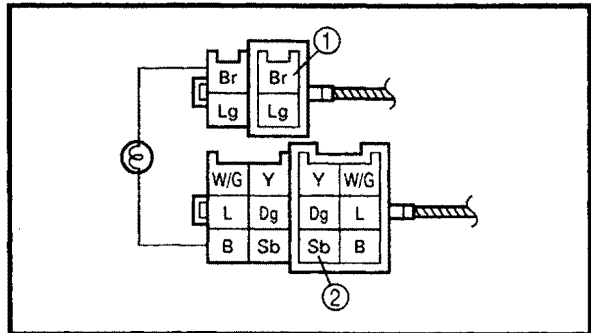

- Turn the main switch to "ON".
- Check the voltage (12 V).

↓ MEETS SPECIFICATION

This circuit is not faulty.

OUT OF SPECIFICATION

The wiring circuit from the main switch to the bulb socket connector is faulty, repair it.

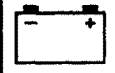

EB808000

FUEL PUMP SYSTEM

CIRCUIT DIAGRAM

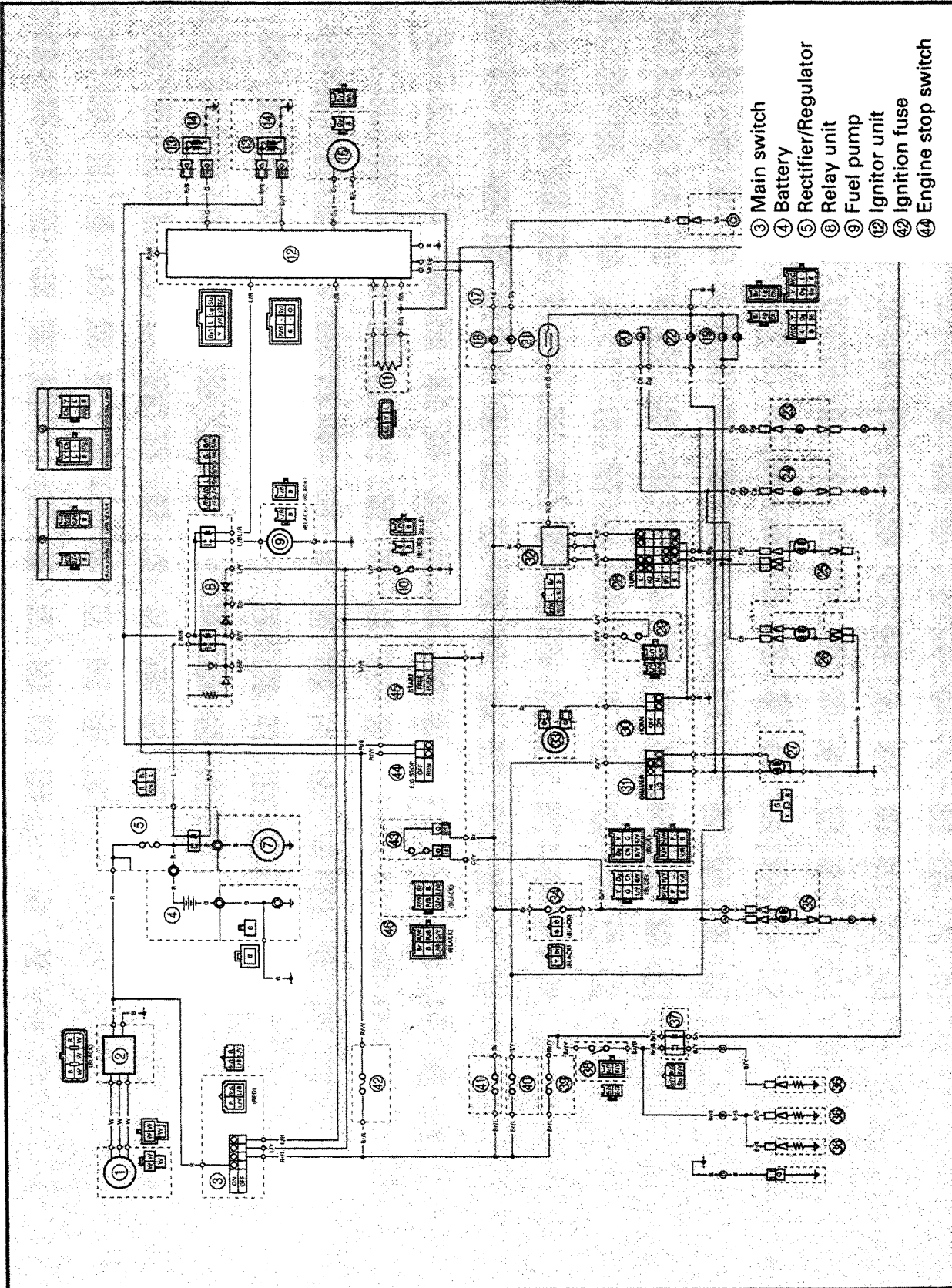



EB808010

FUEL PUMP CIRCUIT OPERATION

The fuel pump circuit consists of the fuel pump relay, fuel pump, engine stop switch and ignitor unit.

The ignitor unit includes the control unit for the fuel pump.

- ① Battery
- ② Main fuse
- ③ Main switch
- ④ Ignition fuse
- ⑤ Engine stop switch
- ⑥ Ignitor unit
- ⑦ Fuel pump relay
- ⑧ Fuel pump

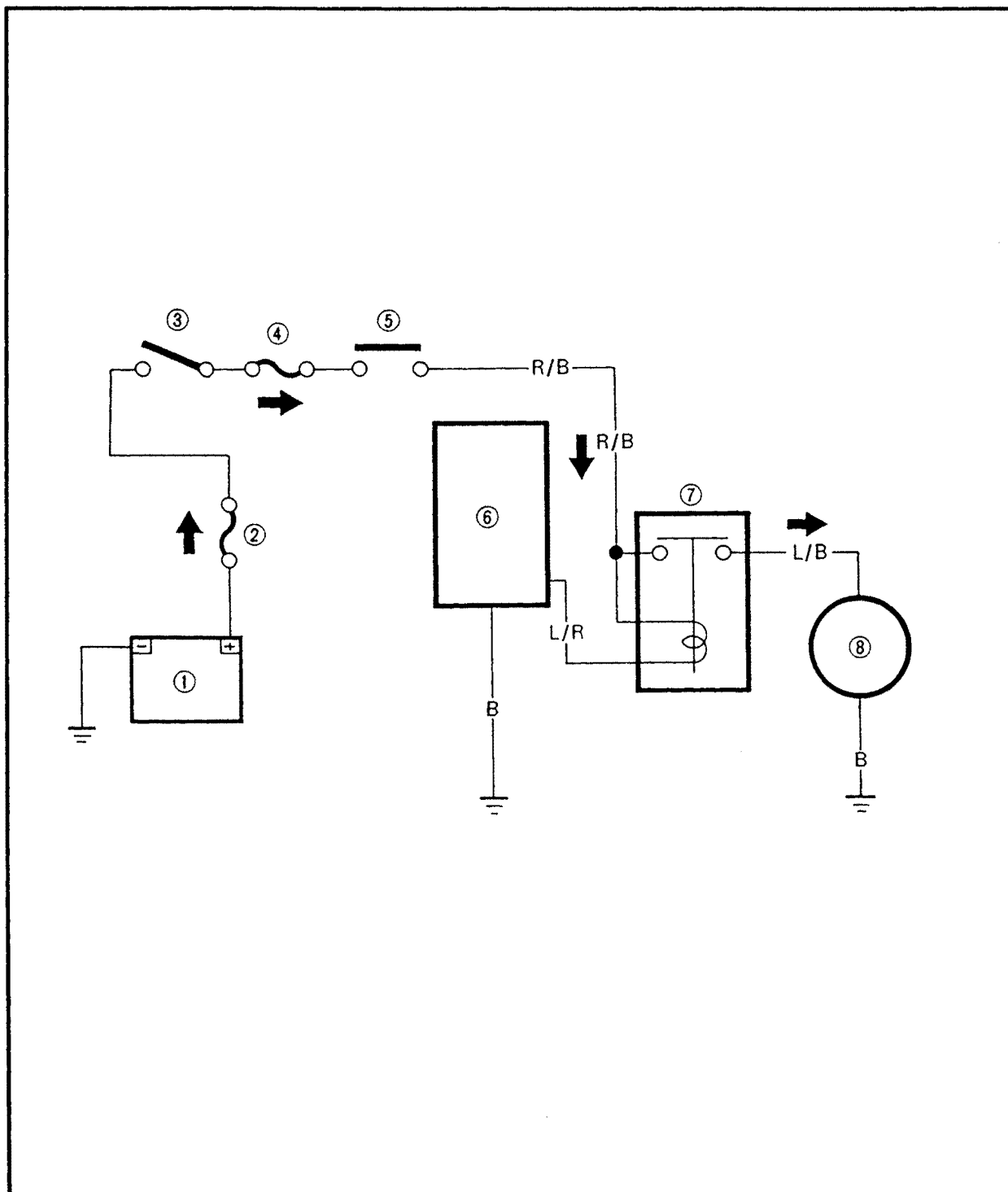

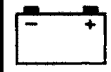

EB808020

TROUBLESHOOTING

IF THE FUEL PUMP FAILS TO OPERATE:

Procedure

Check:

1. Fuses (main and ignition)
2. Battery
3. Main switch
4. Engine stop switch
5. Relay unit (fuel pump relay)
6. Fuel pump
7. Wiring connections (the entire fuel system)

NOTE:

- Remove the following part(s) before troubleshooting:
 - 1) Battery cover
 - 2) Rider's seat
 - 3) Fuel tank
 - 4) Steering head side covers
- Use the following special tool(s) for troubleshooting.



Pocket tester:
YU-03112, 90890-03112

EB802011

1. Fuses (main and ignition)

Refer to "SWITCH INSPECTION".



CONTINUITY

NO CONTINUITY

Replace the fuse(s).

EB802012

2. Battery

- Check the battery condition.
Refer to "BATTERY INSPECTION" in CHAPTER 3.

Open-circuit voltage:
12.8 V or more at 20°C (68°F)



CORRECT

INCORRECT

- Clean the battery terminals.
- Recharge or replace the battery.

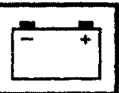

3. Main switch
Refer to "SWITCH INSPECTION".

INCORRECT



Replace main switch.



4. Engine stop switch
Refer to "SWITCH INSPECTION".

INCORRECT



Replace handlebar switch (right).



CORRECT

EB803023

5. Relay unit (fuel pump relay)

- Remove the relay unit from the wire harness.
- Connect the pocket tester ($\Omega \times 1$) and battery (12 V) to the relay unit terminals.

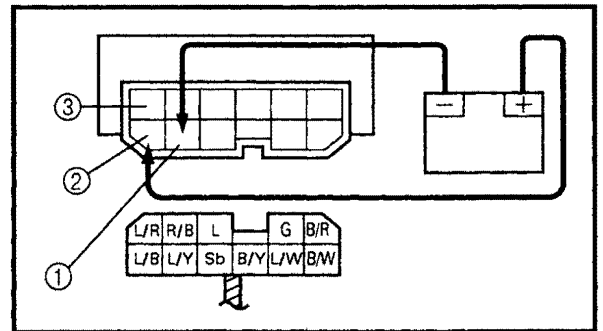

Battery (+) terminal → **Red/Black terminal ①**
Battery (-) terminal → **Blue/Red terminal ②**

Tester (+) lead → **Red/Black terminal ①**
Tester (-) lead → **Blue/Black terminal ③**

- Check the fuel pump relay for continuity.

NO CONTINUITY



Replace the relay unit.



CONTINUITY

EB808021

6. Fuel pump resistance

- Disconnect the fuel pump coupler from the wire harness.
- Connect the pocket tester ($\Omega \times 1$) to the fuel pump coupler terminals.

Tester (+) lead → **Blue/Black terminal ①**
Tester (-) lead → **Black terminal ②**

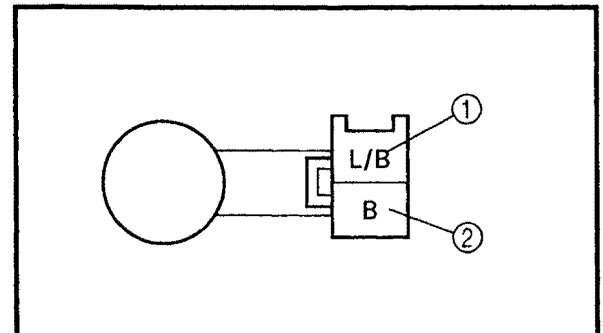

FUEL PUMP SYSTEM



• Check if the fuel pump has the specified resistance.

 **Fuel pump resistance:**
1.6 ~ 2.2 Ω at 20°C (68°F)

MEET SPECIFICATION

EB808022

7. Wiring connections

• Check the connections of the entire fuel pump system. Refer to "CIRCUIT DIAGRAM".

CORRECT

Replace the ignitor unit.

OUT OF SPECIFICATION



Replace the fuel pump.

POOR CONNECTION



Properly connect the fuel pump system.

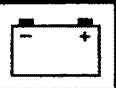

EB808030
FUEL PUMP TEST

⚠ WARNING

Gasoline is extremely flammable and under certain circumstances there can be a danger of an explosion or combustion. Be extremely careful and note the following points:

- Stop the engine before refuelling.
- Do not smoke and keep away from open flames, sparks, or any other source of fire.
- Take care not to spill gasoline. If you do accidentally spill some, wipe it up immediately with dry rags.
- If gasoline touches the engine when the engine is still hot, there is a danger of combustion. Make sure that the engine is completely cool before performing the following test.

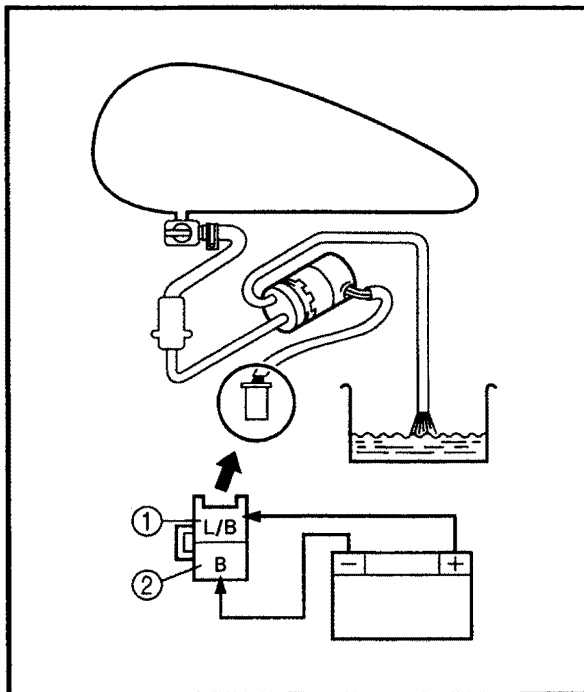

1. Check:

- Fuel pump operation

Checking steps:

- Fill up the fuel tank.
- Put the end of the fuel hose into an open container.
- Connect the battery (12 V) to the fuel pump coupler terminals.

Battery (+) lead → Blue/Black terminal ①
Battery (-) lead → Black terminal ②

- If fuel flows out from the fuel hose, the fuel pump is good. If not, replace the fuel pump assembly.

CARBURETOR HEATER SYSTEM

ELEC



CARBURETOR HEATER SYSTEM CIRCUIT DIAGRAM

- ③ Main switch
- ④ Battery
- ⑤ Main fuse
- ⑬ Neutral switch
- ⑮ Carburetor heater
- ⑯ Carburetor heater relay
- ⑰ Thermo switch
- ⑱ Carburetor heater fuse

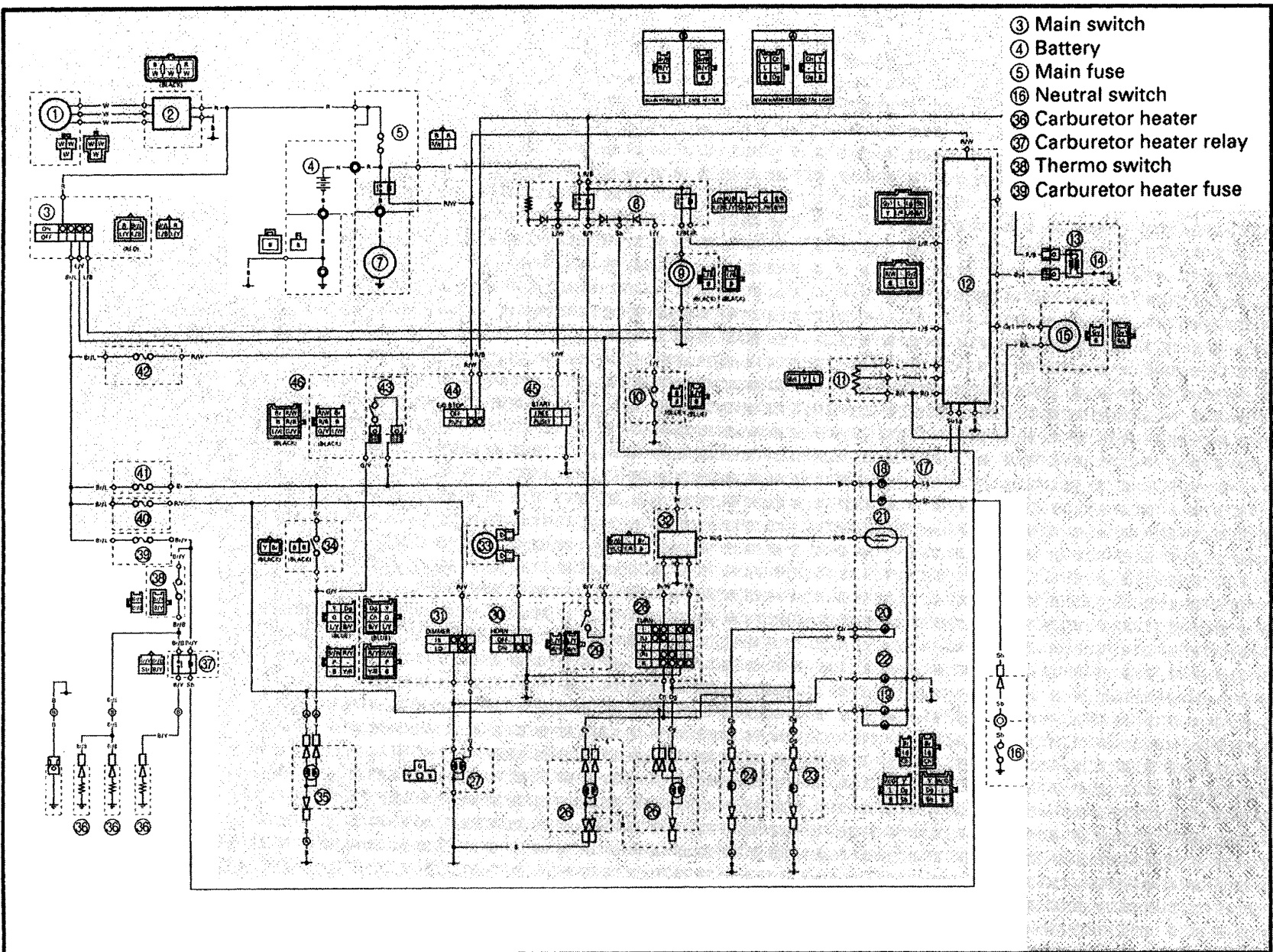

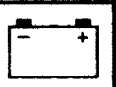

TROUBLESHOOTING

IF THE CARBURETOR HEATER FAILS TO OPERATE:

Procedure

Check:

1. Fuses (main and carburetor heater)
2. Battery
3. Main switch
4. Neutral switch

5. Carburetor heater relay
6. Thermo switch
7. Carburetor heater
8. Wiring connections
(the entire carburetor heater system)

NOTE:

- Remove the following part(s) before troubleshooting:
 - 1) Battery cover
 - 2) Rider's seat
 - 3) Fuel tank
 - 4) Steering head side covers
- Use the following special tool(s) for troubleshooting.

Pocket tester:
YU-03112, 90890-03112

EB802011

1. Fuses (main and carburetor heater)
Refer to "SWITCH INSPECTION".

↓ CONTINUITY

NO CONTINUITY
↓

Replace the fuses.

EB802012

2. Battery

- Check the battery condition.
Refer to "BATTERY INSPECTION" in CHAPTER 3.

Open-circuit voltage:
12.8 V or more at 20°C (68°F)

↓ CORRECT
*

INCORRECT
↓

- Clean the battery terminals.
- Recharge or replace the battery.

CARBURETOR HEATER SYSTEM



3. Main switch
Refer to "SWITCH INSPECTION".

INCORRECT



CORRECT

Replace main switch.

4. Neutral switch
Refer to "SWITCH INSPECTION".

INCORRECT



CORRECT

Replace neutral switch.

5. Carburetor heater relay

- Remove the carburetor heater relay from the wire harness.
- Connect the pocket tester ($\Omega \times 1$) and battery (12 V) to the carburetor heater relay terminals.

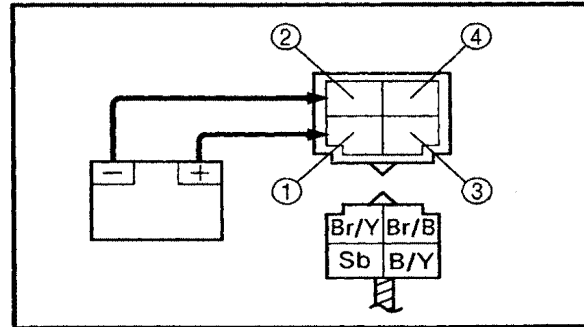

Battery (+) terminal → Brown/Yellow terminal ①
Battery (-) terminal → Sky blue terminal ②

Tester (+) lead → Brown/Black terminal ③
Tester (-) lead → Black/Yellow terminal ④

CONTINUITY

- Check the carburetor heater relay for no continuity.

Replace carburetor heater relay.



NO CONTINUITY

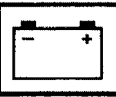

6. Thermo switch

- Remove the thermo switch from the thermo switch plate.
- Connect the pocket tester to the thermo switch lead.

Tester (+) lead → **Brown/Yellow terminal** ①
Tester (-) lead → **Black/Yellow terminal** ②

- Immerse the thermo switch in the water ③.
- Check the thermo switch for continuity. Note the temperatures while heating the water with the temperature gauge ④.

Test step	Water temperature	Good condition
1	Less than 23 ± 3°C (73.4 ± 5.4°F)	○
2	More than 23 ± 3°C (73.4 ± 5.4°F)	×
3	More than 12 ± 4°C (53.6 ± 7.2°F)	×
4	Less than 12 ± 4°C (53.6 ± 7.2°F)	○

Test 1 & 2: Heat-up test
Test 3 & 4: Cool-down test
 ○: Continuity ×: No continuity

- If condition is not good, replace the thermo switch.

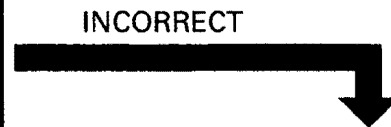
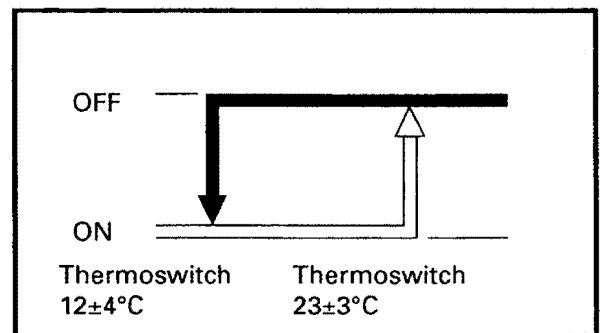
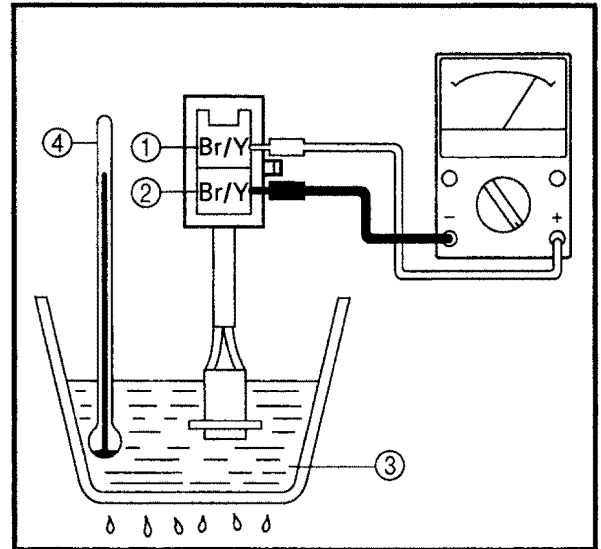

Replace thermo switch.



7. Carburetor heater

- Remove the carburetor heater from the carburetor body.
- Connect the pocket tester to the carburetor heater.

Tester (+) lead → **Heater terminal** ①
Tester (-) lead → **Heater body** ②

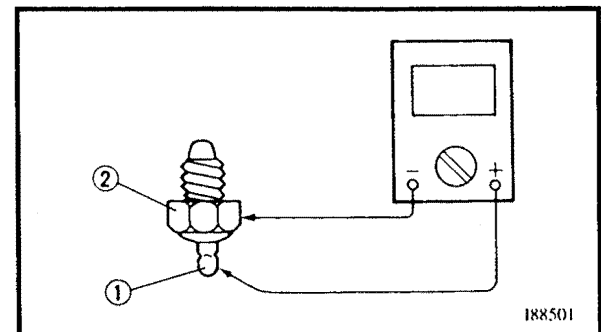

188501

CARBURETOR HEATER SYSTEM

ELEC

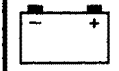

- Measure the heater resistance.



Carburetor heater resistance:
12V15W : 6 ~ 12 Ω at 20°C (68°F)
12V30W : 6 ~ 10 Ω at 20°C (68°F)

INCORRECT

Replace carburetor heater.



CORRECT

1. Wiring connection

- Check the connections of the carburetor heater system.
Refer to "CIRCUIT DIAGRAM".

POOR CONNECTION

Properly connect the carburetor heater system.



SELF-DIAGNOSIS

The XVS650AK/(C) features self-diagnosis.

When the main switch is turned to "ON", the following items are monitored and the condition codes are displayed on the engine indicator light (irrespective of whether the engine is running or not).

NOTE:

The XVS650AK/(C) features a self-diagnosing system.

In the XVS650AK/(C), when the main switch is turned on the "Engine indicator light" in the speedometer comes on for 1.4 seconds then goes off. However, if there is a malfunction, it comes on for 1.4 seconds, goes off and then begins flashing. (However, it is on while the engine is running.)

Item	Condition	Response	Display condition code	
			When engine is stationary	When engine is running
Throttle position sensor (TPS)	Disconnected Short-circuit Locked	<ul style="list-style-type: none"> Enables the motorcycle to run so that the ignition timing is fixed when the throttle is fully opened. Displays the condition code on the engine indicator light. 	Blinks in	Light on

Display order on the engine indicator light

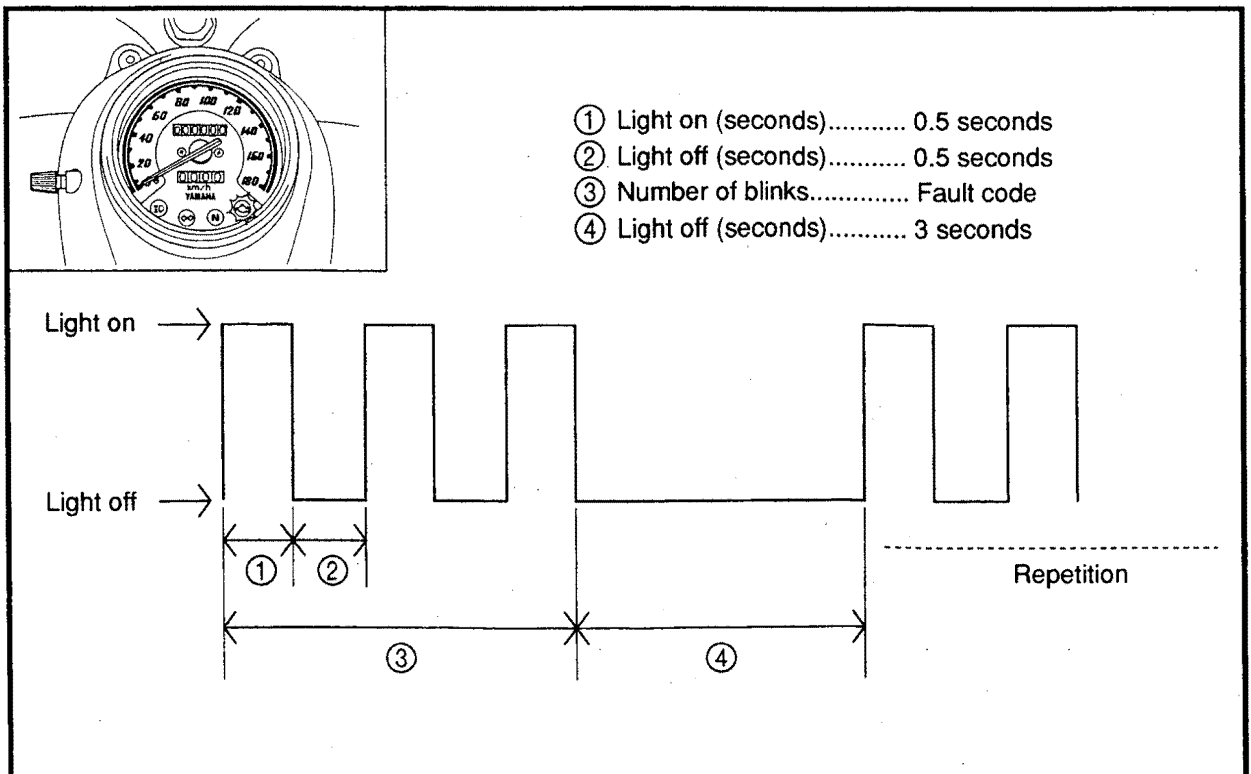



TROUBLESHOOTING

The engine indicator light starts to display the self-diagnosis sequence.

NOTE: Use the following special tool in this troubleshooting.



Pocket tester:
YU-03112, 90890-03112

1. Throttle position sensor (TPS)

CIRCUIT DIAGRAM

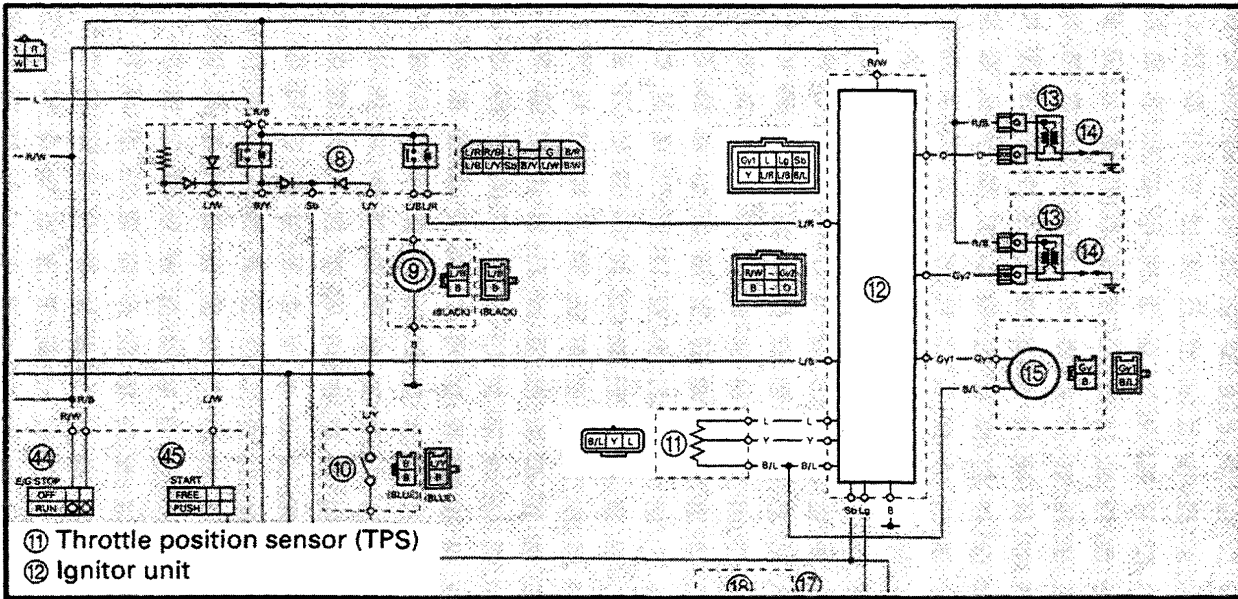

1. Wire harness
• Check the wire harness for continuity. Refer to "CIRCUIT DIAGRAM".

NO CONTINUITY

Repair or replace the wire harness.

CONTINUITY

2. TPS
• Check the TPS for continuity.
• Refer to "THROTTLE POSITION SENSOR (TPS) INSPECTION AND ADJUSTMENT" in CHAPTER 5.

BAD CONDITION

Replace the TPS.

GOOD CONDITION

Replace the ignitor unit.

TROUBLESHOOTING

NOTE:

The following guide for troubleshooting does not cover all the possible causes of problems. It should be helpful, however, as a guide to troubleshooting. Refer to the relative procedure in this manual for inspection, adjustment and replacement of parts.

STARTING FAILURE/HARD STARTING

FUEL SYSTEM

Fuel tank

- Empty
- Clogged fuel filter
- Clogged fuel strainer
- Clogged fuel tank drain hose
- Clogged roll-over valve
- Clogged roll-over valve breather hose
- Deteriorated or contaminated fuel

Fuel cock

- Clogged fuel hose

Carburetor

- Deteriorated or contaminated fuel
- Clogged pilot jet
- Clogged pilot air passage
- Sucked-in air
- Deformed float
- Worn needle valve
- Improperly sealed valve seat
- Improperly adjusted fuel level
- Improperly set pilot jet
- Clogged starter jet
- Faulty starter plunger
- Improperly adjusted starter cable

Air filter

- Clogged air filter element

Fuel pump

- Faulty fuel pump
- Faulty relay unit (fuel pump relay)

ELECTRICAL SYSTEM

Spark plug

- Improper plug gap
- Worn electrodes
- Wire between terminals severed
- Improper heat range
- Faulty spark plug cap

Ignition coil

- Broken or shorted primary/secondary
- Faulty spark plug lead
- Broken body

Full-transistor system

- Faulty ignitor unit
- Faulty pickup coil

Switch and wiring

- Faulty main switch
- Faulty engine stop switch
- Broken or shorted wiring
- Faulty neutral switch
- Faulty start switch
- Faulty sidestand switch
- Faulty clutch switch

Starter motor

- Faulty starter motor
- Faulty starter relay
- Faulty relay unit (starter circuit cut-off relay)
- Faulty starter clutch



COMPRESSION SYSTEM

Cylinder and cylinder head

- Loose spark plug
- Loose cylinder head or cylinder
- Faulty cylinder head gasket
- Worn, damaged or seized cylinder
- Improperly sealed valve
- Improper valve-to-valve seat contact
- Improper valve timing
- Faulty valve spring

Piston and piston ring

- Improperly installed piston ring
- Worn, fatigued or broken piston ring
- Seized piston ring
- Seized or damaged piston

Crankcase and crankshaft

- Improperly seated crankcase
- Seized crankshaft

EB901000

POOR IDLE SPEED PERFORMANCE

POOR IDLE SPEED PERFORMANCE

Carburetor

- Improperly returned starter plunger
- Loose pilot jet
- Clogged pilot air jet
- Improperly synchronized carburetors
- Improperly adjusted idle speed (throttle stop screw)
- Improper throttle cable free play
- Flooded carburetor

Electrical system

- Faulty battery
- Faulty spark plug
- Faulty ignitor unit
- Faulty pickup coil
- Faulty ignition coil

Valve train

- Improperly adjusted valve clearance

Air filter

- Clogged air filter element

EB902000

POOR MEDIUM-AND HIGH-SPEED PERFORMANCE

POOR MEDIUM-AND HIGH-SPEED PERFORMANCE

Refer to "STARTING FAILURE/HARD STARTING". (Fuel system, electrical system, compression system and valve train)

Carburetor

- Faulty diaphragm
- Improperly adjusted fuel level
- Clogged or loose main jet

Air filter

- Clogged air filter element

Fuel pump

- Faulty fuel pump

EB903000

FAULTY GEAR SHIFTING

HARD SHIFTING

Refer to "CLUTCH DRAGGING".

SHIFT PEDAL DOES NOT MOVE

Shift shaft

- Improperly adjusted shift pedal link
- Bent shift shaft

Shift cam, shift fork

- Groove jammed with impurities
- Seized shift fork
- Bent shift fork guide bar

Transmission

- Seized transmission gear
- Jammed impurities
- Incorrectly assembled transmission

JUMPS-OUT-OF GEAR

Shift shaft

- Improperly adjusted shift lever position
- Improperly returned stopper lever

Shift fork

- Worn shift fork

Shift cam

- Improper thrust play
- Worn shift cam groove

Transmission

- Worn gear dog

EB904000

CLUTCH SLIPPING/Dragging

CLUTCH SLIPPING

Clutch

- Improperly adjusted clutch cable
- Loose clutch spring
- Fatigued clutch spring
- Worn friction plate/clutch plate
- Incorrectly assembled clutch

Engine oil

- Improper oil level
- Improper viscosity (low)
- Deterioration

CLUTCH DRAGGING

Clutch

- Warped pressure plate
- Unevenly tensioned clutch springs
- Bent push rod
- Broken clutch boss
- Burnt primary driven gear bushing
- Bent clutch plate
- Swollen friction plate
- Match marks not aligned

Engine oil

- Improper oil level
- Improper viscosity (high)
- Deterioration

EB905000

OVERHEATING

OVERHEATING

Ignition system

- Improper spark plug gap
- Improper spark plug heat range
- Faulty ignitor unit

Fuel system

- Improper carburetor main jet setting
- Improper fuel level
- Clogged air filter element

Compression system

- Heavy carbon build-up

Engine oil

- Improper oil level
- Improper oil viscosity
- Inferior oil quality

Brake

- Brake drag

EB906001

FAULTY BRAKE

POOR BRAKING EFFECT

Disc brake

- Worn brake pad
- Worn disc
- Air in brake fluid
- Leaking brake fluid
- Faulty cylinder kit cup
- Faulty caliper kit seal
- Loose union bolt
- Broken brake hose
- Oily or greasy disc/brake pad
- Improper brake fluid level

Drum brake

- Worn brake shoe
- Worn or rusty brake drum
- Improper brake free play adjustment
- Improper brake cam lever position
- Improper brake shoe position
- Fatigue/faulty return spring
- Oily or greasy brake shoe/brake drum
- Broken brake rod

EB907000

FRONT FORK OIL LEAKAGE AND FRONT FORK MALFUNCTION

MALFUNCTION

- Bent, deformed or damaged inner tube
- Bent or deformed outer tube
- Damaged fork spring
- Worn or damaged slide metal
- Bent or damaged damper rod
- Improper oil viscosity
- Improper oil level

OIL LEAKAGE

- Bent, damaged or rusty inner tube
- Damaged or cracked outer tube
- Damaged oil seal lip
- Improperly installed oil seal
- Improper oil level (too high)
- Loose damper rod holding bolt
- Broken cap bolt O-ring
- Loose drain bolt
- Damaged drain bolt gasket

EB908000

UNSTABLE HANDLING

UNSTABLE HANDLING

Handlebar

- Improperly installed or bent

Steering

- Improperly installed handlebar crown
- Bent steering stem
- Improperly installed steering shaft (improperly tightened ring nut)
- Damaged ball bearing or bearing race

Swingarm

- Worn bearing or bushing
- Bent or damaged

Rear shock absorber

- Faulty spring
- Oil and gas leakage

Tire

- Uneven tire pressures on both sides
- Incorrect tire pressure
- Uneven tire wear

Front fork

- Uneven oil levels on both sides
- Uneven spring tension (uneven damping force adjuster position)
- Broken spring
- Twisted front fork

Wheel

- Incorrect wheel balance
- Deformed cast wheel
- Damaged bearing
- Bent or loose wheel axle
- Excessive wheel runout
- Loosed spoke

Frame

- Bent
- Damaged steering head tube
- Improperly installed bearing race

EB909000

FAULTY LIGHTING AND SIGNAL SYSTEMS

HEADLIGHT DOES NOT LIGHT

- Improper bulb
- Too many electric accessories
- Hard charging (broken stator coil wire, faulty rectifier/regulator)
- Incorrect connection
- Improperly grounded
- Poor contacts (main or lights switch)
- Bulb life expired

FLASHER DOES NOT LIGHT

- Improperly grounded
- Discharged battery
- Faulty turn switch
- Faulty flasher relay
- Faulty wire harness
- Loosely connected coupler
- Burnt-out bulb
- Faulty fuse

FLASHER BLINKS SLOWLY

- Faulty flasher relay
- Faulty main and/or turn switch
- Improper bulb

BULB BURNT OUT

- Improper bulb
- Faulty battery
- Faulty rectifier/regulator
- Improperly grounded
- Faulty main and/or lights switch
- Bulb life expired

FLASHER REMAINS LIT

- Faulty flasher relay
- Burnt-out bulb

FLASHER BLINKS QUICKLY

- Improper bulb
- Faulty flasher relay
- Burnt-out bulb

HORN DOES NOT SOUND

- Faulty battery
- Faulty fuse
- Faulty main and/or horn switch
- Improperly adjusted horn
- Faulty horn
- Broken wire harness

XVS650AK(C) WIRING DIAGRAM

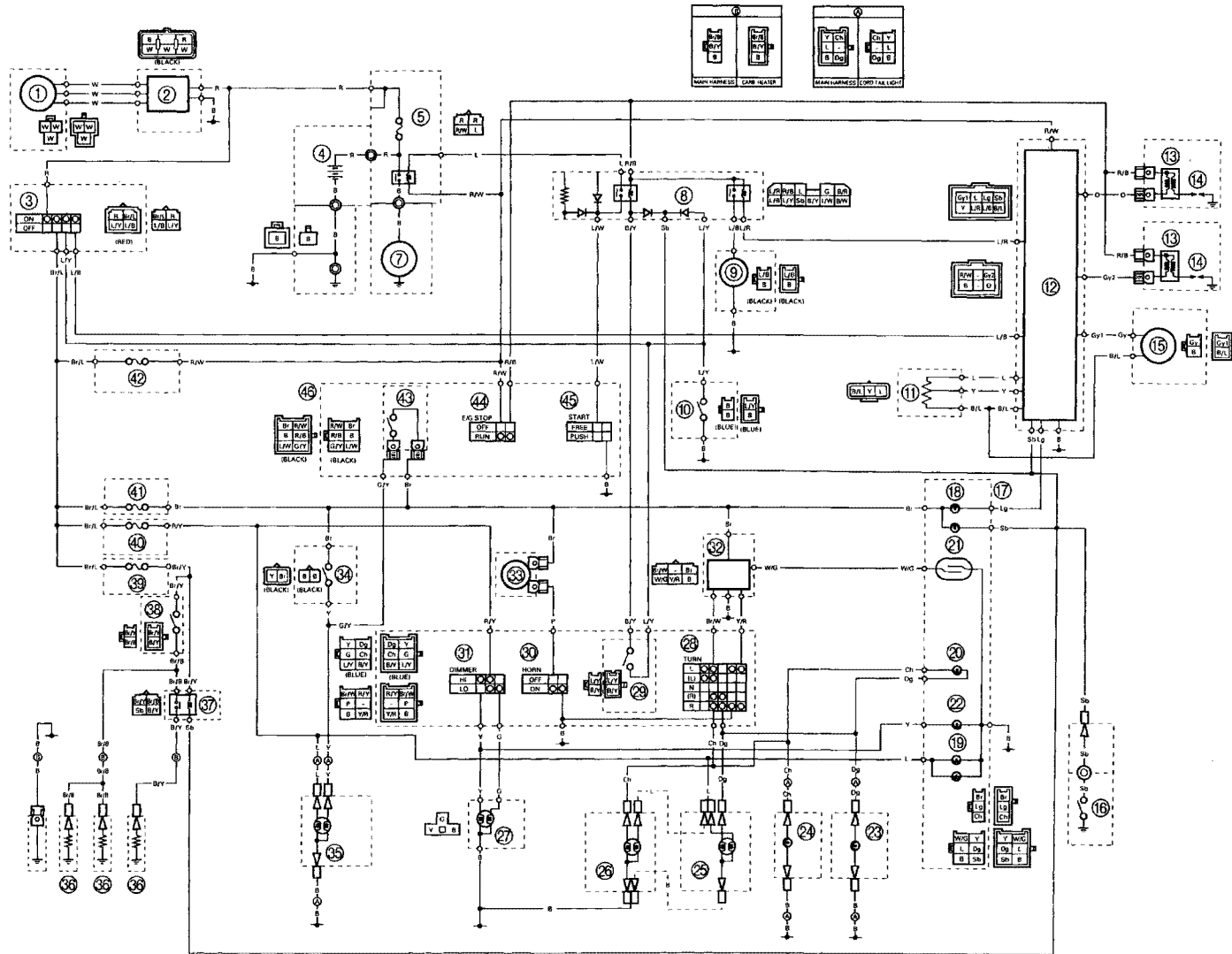

- ① A.C. magneto
- ② Rectifier/regulator
- ③ Main switch
- ④ Battery
- ⑤ Main fuse
- ⑥ Starter relay
- ⑦ Starter motor
- ⑧ Relay unit
- ⑨ Fuel pump
- ⑩ Sidestand switch
- ⑪ Throttle position sensor (TPS)
- ⑫ Ignitor unit
- ⑬ Ignition coil
- ⑭ Spark plug
- ⑮ Pickup coil
- ⑯ Neutral switch
- ⑰ Meter assembly
- ⑱ Engine warning light
- ⑲ Meter light
- ⑳ Turn indicator light
- ㉑ Neutral indicator light
- ㉒ High beam indicator light
- ㉓ Rear turn signal (R)
- ㉔ Rear turn signal (L)
- ㉕ Front turn signal (R)
- ㉖ Front turn signal (L)
- ㉗ Headlight
- ㉘ Turn switch
- ㉙ Clutch switch
- ㉚ Horn switch
- ㉛ Dimmer switch
- ㉜ Flasher relay
- ㉝ Horn
- ㉞ Rear brake switch
- ㉟ Tail/brake light
- ㊱ Carburetor heater
- ㊲ Carburetor heater relay
- ㊳ Thermo switch
- ㊴ Carburetor heater fuse
- ㊵ Headlight fuse
- ㊶ Signal system fuse
- ㊷ Ignition fuse
- ㊸ Front brake switch
- ㊹ Engine stop switch
- ㊺ Start switch
- ㊻ Right handlebar switch

COLOR CODE

B.....Black	L.....Blue	W.....White	Br/L.....Brown/Blue	L/W.....Blue/White
Br.....Brown	Lg.....Light green	Y.....Yellow	Br/W.....Brown/White	L/Y.....Blue/Yellow
Ch.....Chocolate	O.....Orange	B/L.....Black/Blue	Br/Y.....Brown/Yellow	R/B.....Red/Black
Dg.....Dark green	P.....Pink	B/W.....Black/White	G/Y.....Green/Yellow	R/W.....Red/White
G.....Green	R.....Red	B/Y.....Black/Yellow	L/B.....Blue/Black	R/Y.....Red/Yellow
Gy.....Gray	Sb.....Sky blue	Br/B.....Brown/Black	L/R.....Blue/Red	

YAMAHA

XVS650K(C)

**SUPPLEMENTARY
SERVICE MANUAL**

FOREWORD

This Supplementary Service Manual has been prepared to introduce new service and data for the XVS650K(C). For complete service information procedures it is necessary to use this Supplementary Service Manual together with the following manual.

XVS650AK(C) SERVICE MANUAL: LIT-11616-11-16 (5BN-28197-E0)

**XVS650K(C)
SUPPLEMENTARY
SERVICE MANUAL**

© 1997 by Yamaha Motor Corporation, U.S.A.

First edition, December 1997

All rights reserved.

**Any reproduction or unauthorized use
without the written permission of
Yamaha Motor Corporation, U.S.A.
is expressly prohibited.**

Printed in U.S.A.

P/N LIT-11616-11-21

NOTICE

This manual was produced by the Yamaha Motor Company primarily for use by Yamaha dealers and their qualified mechanics. It is not possible to include all the knowledge of a mechanic in one manual, so it is assumed that anyone who uses this book to perform maintenance and repairs on Yamaha motorcycles has a basic understanding of the mechanical ideas and the procedures of motorcycle repair. Repairs attempted by anyone without this knowledge are likely to render the motorcycle unsafe and unfit for use.

This model has been designed and manufactured to perform within certain specifications in regard to performance and emissions. Proper service with the correct tools is necessary to ensure that the motorcycle will operate as designed. If there is any question about a service procedure, it is imperative that you contact a Yamaha dealer for any service information changes that apply to this model. This policy is intended to provide the customer with the most satisfaction from his motorcycle and to conform with federal environmental quality objectives.

Yamaha Motor Company, Ltd. is continually striving to improve all of its models. Modifications and significant changes in specifications or procedures will be forwarded to all authorized Yamaha dealers and will appear in future editions of this manual where applicable.

NOTE:

- This Service Manual contains information regarding periodic maintenance to the emission control system. Please read this material carefully.
- Designs and specifications are subject to change without notice.

IMPORTANT INFORMATION

Particularly important information is distinguished in this manual by the following notations.



The Safety Alert Symbol means ATTENTION! BECOME ALERT! YOUR SAFETY IS INVOLVED!



Failure to follow WARNING instructions could result in severe injury or death to the motorcycle operator, a bystander or a person inspecting or repairing the motorcycle.



A CAUTION indicates special precautions that must be taken to avoid damage to the motorcycle.

NOTE:

A NOTE provides key information to make procedures easier or clearer.

HOW TO USE THIS MANUAL

MANUAL ORGANIZATION

This manual consists of chapters for the main categories of subjects. (See "Illustrated symbols".)

1st title ①: This is the title of the chapter with its symbol in the upper right corner of each page.

2nd title ②: This title indicates the section of the chapter and only appears on the first page of each section. It is located in the upper left corner of the page.

3rd title ③: This title indicates a sub-section that is followed by step-by-step procedures accompanied by corresponding illustrations.

EXPLODED DIAGRAMS

To help identify parts and clarify procedure steps, there are exploded diagrams at the start of each removal and disassembly section.

1. An easy-to-see exploded diagram ④ is provided for removal and disassembly jobs.
2. Numbers ⑤ are given in the order of the jobs in the exploded diagram. A number that is enclosed by a circle indicates a disassembly step.
3. An explanation of jobs and notes is presented in an easy-to-read way by the use of symbol marks ⑥. The meanings of the symbol marks are given on the next page.
4. Dimension figures and the number of parts ⑦ are given for bolts and screws that have a required tightening torque.
5. A job instruction chart ⑧ accompanies the exploded diagram, providing the order of jobs, names of parts, notes in jobs, etc.
6. For jobs requiring more information, the step-by-step format supplements ⑨ are given in addition to the exploded diagram and the job instruction chart.

CLUTCH COVER

⑤

④

⑦

Order	Job name/Part name	Qty	Remarks
	Clutch cover removal		Remove the parts in the order below. Stand the motorcycle on a level surface. WARNING Securely support the motorcycle so there is no danger of it falling over.
	Engine oil		Refer to "ENGINE OIL REPLACEMENT" in CHAPTER 3.
	Muffler assembly 1,2		Refer to "ENGINE REMOVAL".
1	Brake pedal link	1	
2	Oil filter cover plate	1	L=70 mm x 1, 95 mm x 1, 25 mm x 3
3	O-ring	1	
4	Oil filter	1	
5	Crankcase cover (right)	1	L=85 mm x 1, 95 mm x 1, 45 mm x 4, 30 mm x 4

CLUTCH REMOVAL

③

⑧

1. Straighten:
• Lock washer tab
2. Loosen:
• Nut (clutch boss) ①

NOTE:
Loosen the nut (clutch boss) ① while holding the clutch boss ② with the clutch holding tool ③.

Clutch holding tool:
30830-9A006

PRIMARY DRIVE GEAR REMOVAL

1. Straighten:
• Lock washer tab
2. Loosen:
• Nut (primary drive gear) ①

NOTE:
Place a copper plate ④ between the teeth of the primary drive gear ③ and primary drive gear to lock them.

CLUTCH INSPECTION

1. Inspect:
• Friction plates
Wear/damage → Replace the friction plates as a set.

















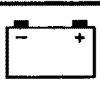





2. Measure:
• Friction plate thickness
Out of specification → Replace the friction plates as a set.
Measure at four places.

Thickness (friction plate):
2.3 - 2.1 mm
◀Wear limit▶: 2.8 mm

3. Inspect:
• Clutch plate
Damage → Replace the clutch plates as a set.

4. Measure:
• Clutch plate warpage
Out of specification → Replace the clutch plates as a set.
Use a surface plate and a feeler gauge ④.

Warp limit (clutch plate):
Less than 0.2 mm

① GEN INFO 	② SPEC 	
③ INSP ADJ 	④ ENG 	
⑤ COOL 	⑥ CARB 	
⑦ CHAS 	⑧ ELEC 	
⑨ TRBL SHTG ?	⑩ 	
⑪ 	⑫ 	
⑬ 	⑭ 	
⑮ 	⑯ 	⑰ 
⑱ 	⑲ 	⑳ 
㉑ 	㉒ 	㉓ 
㉔ 	㉕ New	

EB003000

ILLUSTRATED SYMBOLS

Illustrated symbols ① to ⑨ are printed on the top right of each page and indicate the subject of each chapter.

- ① General information
- ② Specifications
- ③ Periodic inspections and adjustments
- ④ Engine
- ⑤ Cooling system
- ⑥ Carburetion
- ⑦ Chassis
- ⑧ Electrical
- ⑨ Troubleshooting

Illustrated symbols ⑩ to ⑰ are used to identify the specifications appearing in the text.

- ⑩ Can be serviced with engine mounted
- ⑪ Filling fluid
- ⑫ Lubricant
- ⑬ Special tool
- ⑭ Torque
- ⑮ Wear limit, clearance
- ⑯ Engine speed
- ⑰ Ω , V, A

Illustrated symbols ⑱ to ㉓ in the exploded diagrams indicate the types of lubricants and lubrication points.

- ⑱ Apply engine oil
 - ⑲ Apply gear oil
 - ⑳ Apply molybdenum disulfide oil
 - ㉑ Apply wheel bearing grease
 - ㉒ Apply lightweight lithium-soap base grease
 - ㉓ Apply molybdenum disulfide grease
- Illustrated symbols ㉔ to ㉕ in the exploded diagrams indicate where to apply a locking agent ㉔ and when to install new parts ㉕.

- ㉔ Apply locking agent (LOCTITE®)
- ㉕ Replace

CONTENTS

GENERAL INFORMATION	1
MOTORCYCLE IDENTIFICATION	1
VEHICLE IDENTIFICATION NUMBER	1
MODEL LABEL	1
SPECIFICATIONS	2
GENERAL SPECIFICATIONS	2
MAINTENANCE SPECIFICATIONS	3
CHASSIS	3
CABLE ROUTING	4
PERIODIC INSPECTION AND ADJUSTMENTS	13
FUEL TANK AND SEATS	13
HEAD LIGHT BEAM ADJUSTMENT	14
HEAD LIGHT BULB REPLACEMENT	14
CHASSIS	16
FRONT FORK	16
FRONT FORK DISASSEMBLY	19
FRONT FORK INSPECTION	20
FRONT FORK ASSEMBLY	20
FRONT FORK INSTALLATION	23
STEERING HEAD	24

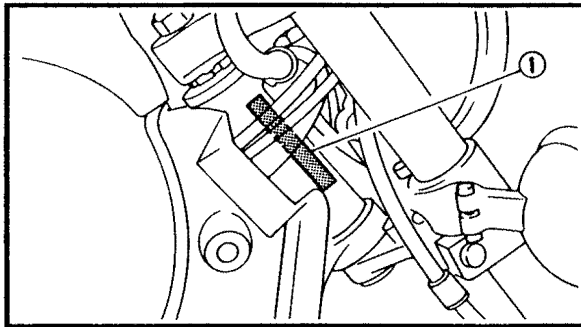

EB100000

GENERAL INFORMATION MOTORCYCLE IDENTIFICATION

EB100010

VEHICLE IDENTIFICATION NUMBER

The vehicle identification number ① is stamped into the right side of the steering head.

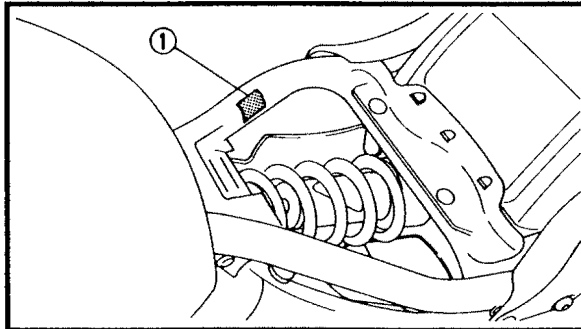

MODEL LABEL

The model label ① is affixed to the frame. This information will be needed to order spare parts.



SPECIFICATIONS

GENERAL SPECIFICATIONS

Model	Standard
Model code:	XVS650: 5FB1 (For USA) 5FB2 (For California) 5FB3 (For Canada)
Dimensions:	
Overall length	2,295 mm (90.4 in)
Overall width	880 mm (34.6 in)
Overall height	1,065 mm (41.9 in)
Seat height	695 mm (27.4 in)
Wheelbase	1,610 mm (63.4 in)
Minimum ground clearance	140 mm (5.5 in)
Minimum turning radius	3,100 mm (122 in)
Basic weight:	
With oil and a full fuel tank	227 kg (501 lb)
Chassis:	
Frame type	Double cradle
Caster angle	35°
Trail	153 mm (6.02 in)
Tire:	
Type	With tube
Size	front 100/90-19 57S rear 170/80-15M/C 77S
Manufacturer	front BRIDGESTONE / DUNLOP rear BRIDGESTONE / DUNLOP
Type	front L309 / F24 rear G546 / K555
Maximum load-except motorcycle:	180 kg (397 lb)
Tire pressure (cold tire):	
0 ~ 90 kg (0 ~ 198 lb) load *	front 200 kPa (2.0 kg/cm ² , 29 psi) rear 225 kPa (2.25 kg/cm ² , 32.6 psi)
90 kg (198 lb) ~ Maximum load *	front 200 kPa (2.0 kg/cm ² , 29 psi) rear 250 kPa (2.50 kg/cm ² , 36.3 psi)
	* Load is the total weight of the cargo, rider, passenger and accessories.
Wheel travel:	
Front wheel travel	140 mm (5.5 in)
Rear wheel travel	86 mm (3.39 in)



MAINTENANCE SPECIFICATIONS
CHASSIS

Item	Standard	Limit
Front suspension:		
Front fork travel	140 mm (5.5 in)	----
Fork spring free length	295 mm (11.6 in)	284 mm (11.18 in)
Fitting length	295 mm (11.6 in)	----
Spring rate (K1)	3.5 N/mm (0.35 kg/mm, 19.6 lb/in)	----
Stroke (K1)	0 ~ 140 mm (0 ~ 5.5 in)	----
Optional spring	No	----
Oil capacity	0.454 L (15.35 US oz)	----
Oil level	114 mm (4.49 in)	----
Oil grade	Fork oil 10W or equivalent	----
Rear suspension:		
Shock absorber travel	37 mm (1.46 in)	----
Spring free length	168.5 mm (6.63 in)	165 mm (6.5 in)
Fitting length	160.5 mm (6.32 in)	----
Spring rate (K1)	186 N/mm (18.6 kg/mm, 1041.6 lb/in)	----
Stroke (K1)	0 ~ 37 mm (0 ~ 1.46 in)	----
Optional spring	No	----
Front wheel:		
Type	Spoke wheel	----
Rim size	19 × MT2.50	----
Rim material	Steel	----
Rim runout limit radial	1.0 mm (0.04 in)	2 mm (0.08 in)
lateral	0.5 mm (0.02 in)	2 mm (0.08 in)
Front brake:		
Type	Single disk	----
Disc outside diameter × thickness	298 × 5 mm (11.73 × 0.2 in)	----
Pad thickness inner	6.2 mm (0.24 in)	0.8 mm (0.03 in)
Pad thickness outer	6.2 mm (0.24 in)	0.8 mm (0.03 in)
Master cylinder inside diameter	12.7 mm (0.5 in)	----
Caliper cylinder inside diameter	30.2 mm (1.19 in)	----
Caliper cylinder inside diameter	33.3 mm (1.31 in)	----
Brake fluid type	DOT 4	----

EB206000

CABLE ROUTING

- | | | |
|--------------------------------|-------------------------------|-------------------|
| ① Frame | ⑩ Sidestand switch lead | ⑲ Spark plug lead |
| ② Clutch cable | ⑪ Rear brake switch lead | ⑳ Fuel pump |
| ③ Left handlebar switch lead | ⑫ Horn | |
| ④ Fuel tank breather hose | ⑬ Headlight lead | |
| ⑤ Speedometer cable | ⑭ Right handlebar switch lead | |
| ⑥ Speedometer | ⑮ Main switch | |
| ⑦ Speedometer light leads | ⑯ Main switch lead | |
| ⑧ Vacuum chamber air vent hose | ⑰ Fuel pump lead | |
| ⑨ Rectifier/regulator | ⑱ Fuel hose | |

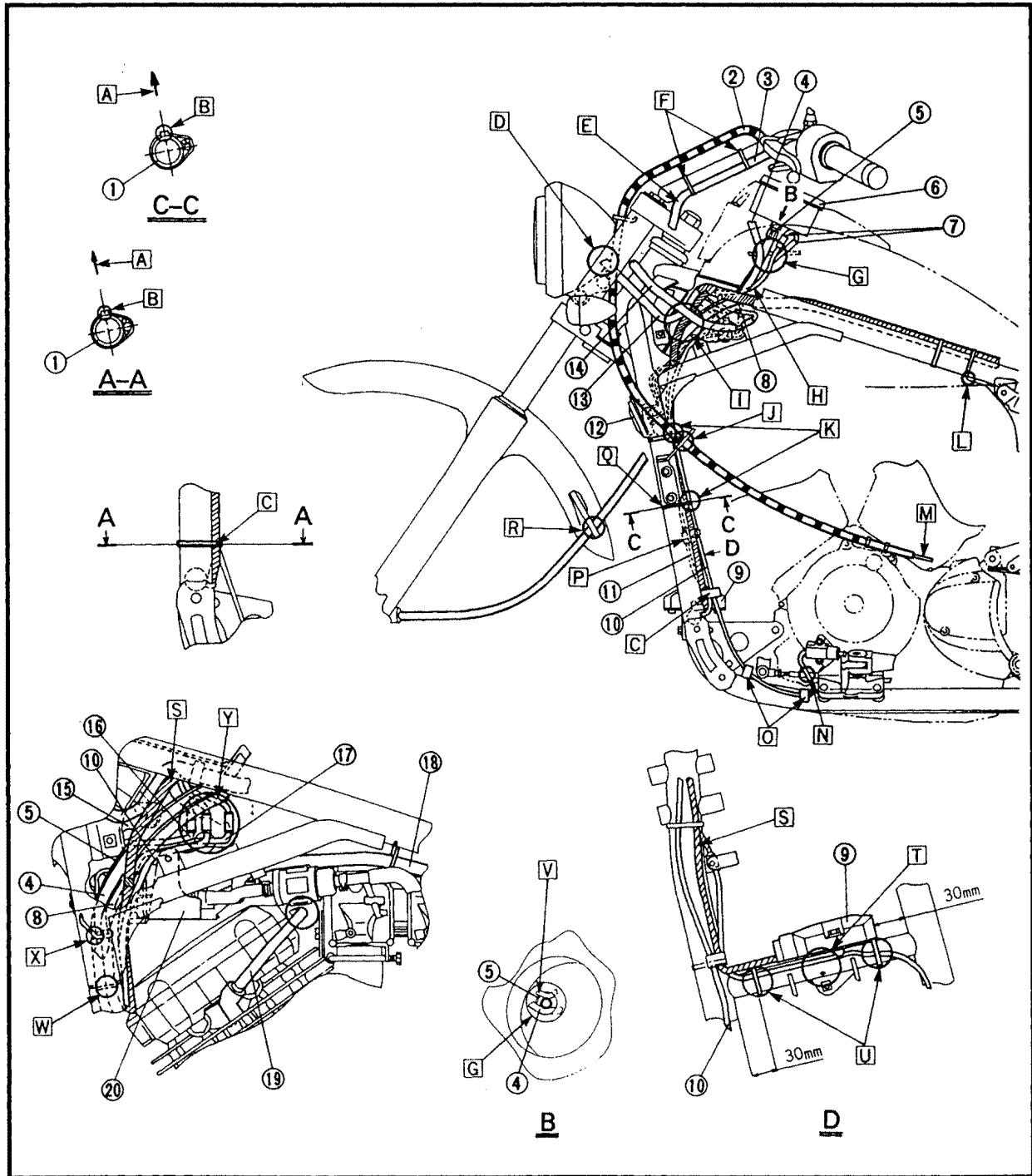



- A** Inside the motorcycle.
- B** Place the end of the plastic locking tie as shown.
- C** Fasten the rear brake switch lead, sidestand switch lead and rectifier/regulator lead with metal clamp or plastic locking tie.
- D** Pass the front flasher light leads (left and right) and headlight lead through the headlight cover hole.
- E** Pass the left handlebar switch lead behind the upper bracket.
- F** Fasten the left handlebar switch lead with a plastic locking tie.
- G** Pass the speedometer cable, speedometer light leads and fuel tank breather hose through the fuel tank hole.
- H** To the speedometer light leads.
- I** Pass the right handlebar switch lead and headlight lead over the other harness and leads.
- J** Pass the clutch cable through the cable guide.
- K** Fasten the sidestand switch lead and rectifier/regulator lead with a plastic locking tie.
- L** Install the plastic locking tie so that it is up against the frame projection.
- M** To the engine.
- N** The sidestand switch lead should not touch the shift rod.

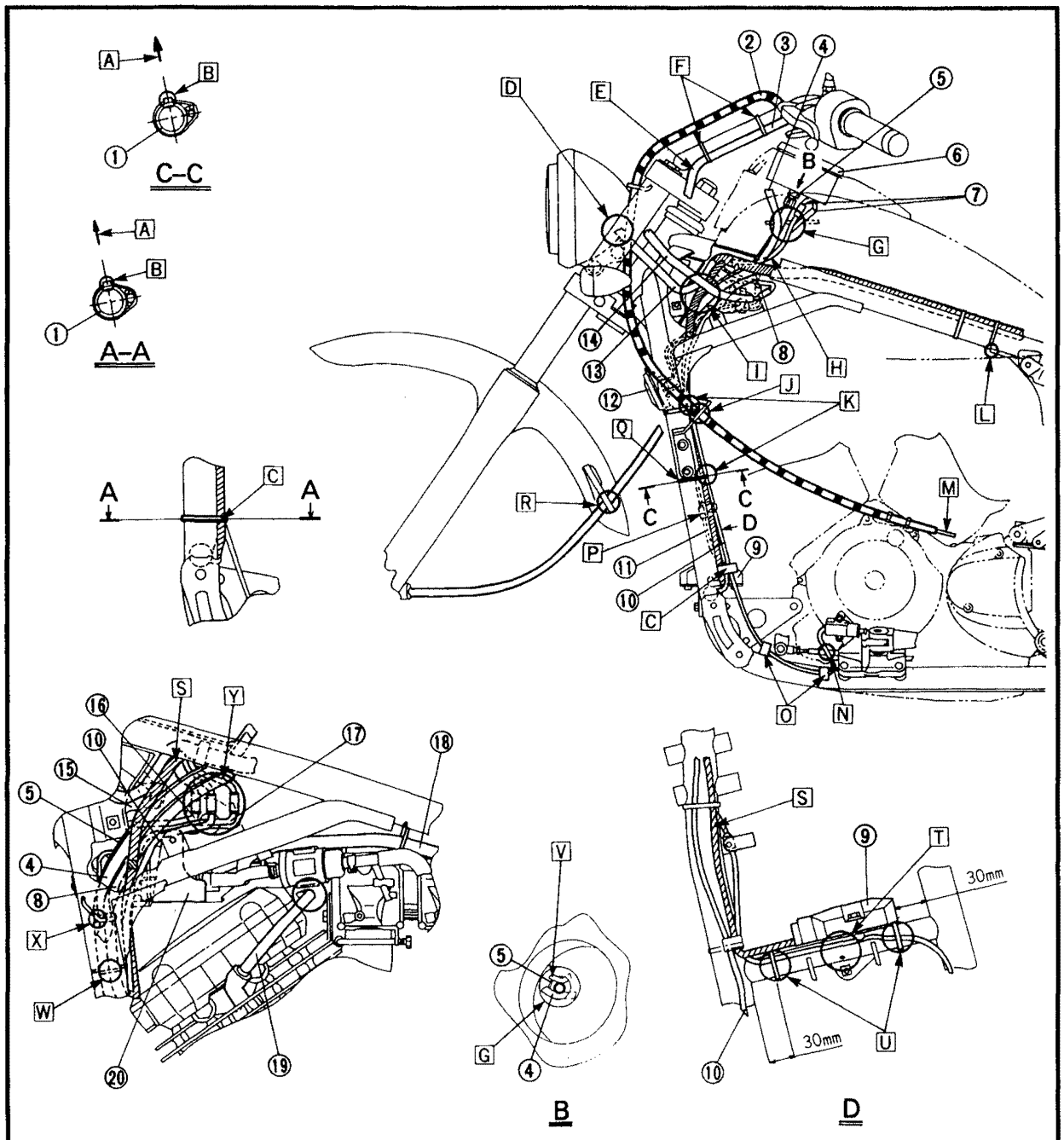

CABLE ROUTING

SPEC



- Q** Fasten the sidestand switch lead with a metal clamp.
- P** Connect the rear brake switch coupler in front of the roll over valve stay.
- Q** Install the plastic locking tie immediately below the cable guide bracket.
- R** Pass the speedometer cable through the speedometer cable holder.
- S** To the rectifier/regulator.
- T** Pass the rear brake switch lead between the frame and rectifier/regulator. Do not pinch the rear brake switch lead.
- U** Fasten the rear brake switch lead with a plastic locking tie.
- V** To the speedometer light leads.
- W** Pass the fuel tank breather hose and vacuum chamber air vent hose through the holder.
- X** Pass the speedometer cable through the holder.
- Y** Place the couplers behind the steering head.

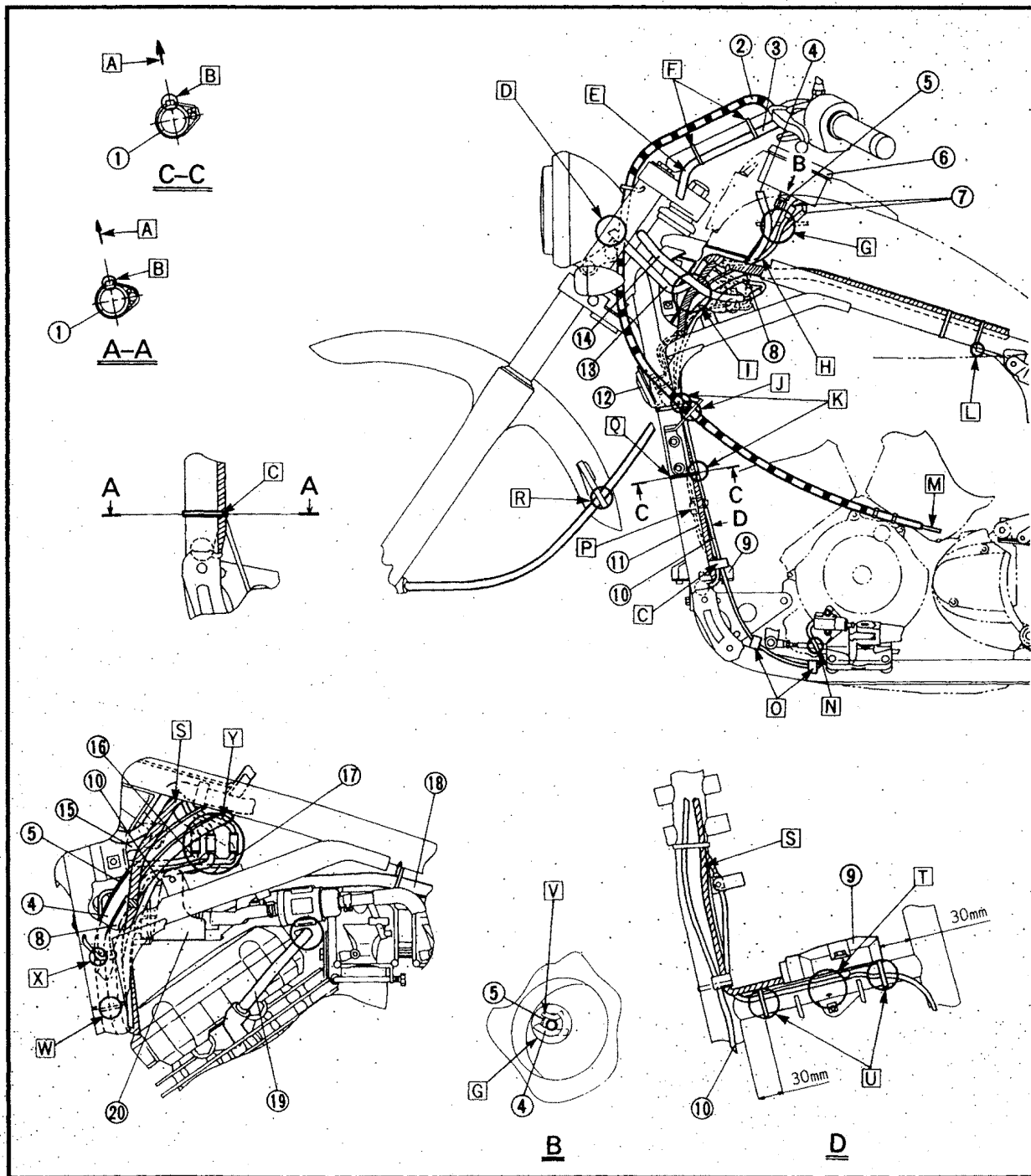



- ① Frame bracket
- ② Dimmer switch
- ③ Self-canceling turn signal relay
- ④ Fuse box
- ⑤ Battery positive (+) lead
- ⑥ Spark plug lead
- ⑦ Vacuum chamber air bent hose
- ⑧ Starter cable
- ⑨ Right handlebar switch lead
- ⑩ Brake hose
- ⑪ Throttle cables
- ⑫ Thermo switch lead
- ⑬ Flasher light relay

- ⑭ Starter relay
- ⑮ Carburetor heater relay
- ⑯ Neutral switch lead
- ⑰ Pickup coil lead
- ⑱ A.C. magneto lead
- ⑲ Battery negative (-) lead
- ⑳ Starter motor lead
- ㉑ Battery cover
- ㉒ Battery
- ㉓ Wire harness
- ㉔ Starting circuit cut-off relay
- ㉕ Fuel tank breather hose
- ㉖ Speedometer cable

- ㉗ Ignitor unit

- [A] Pass the tail/brake light lead between the frame bracket and battery box. Position the mud guard the between the edge of the frame bracket and the tail/brake light lead.
- [B] Fasten the dimmer switch lead with a clamp.
- [C] Fasten the self-canceling turn signal relay lead and battery positive (+) lead with a battery band.

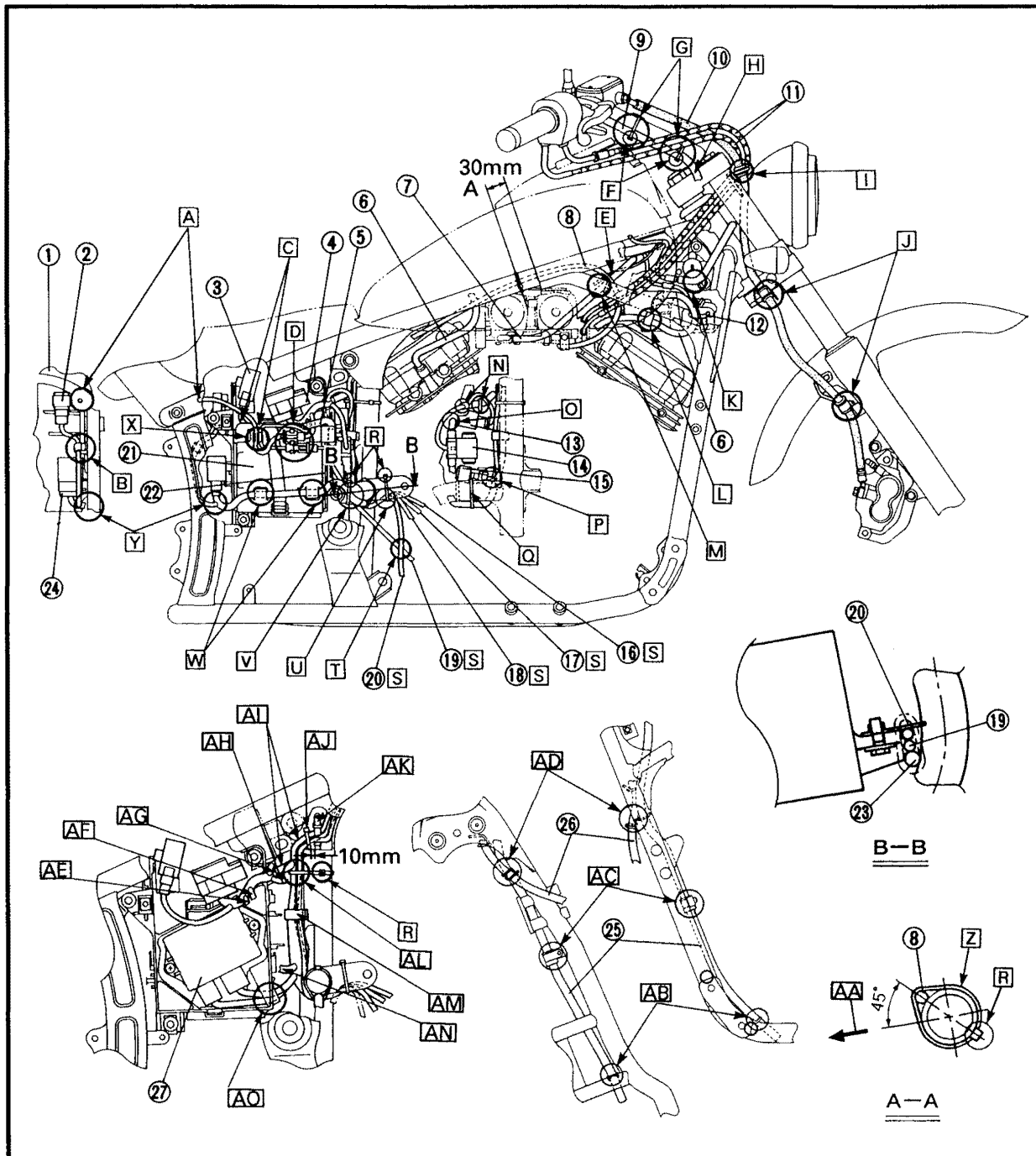

CABLE ROUTING

SPEC



- D Fasten the tail/brake light lead coupler and battery negative (-) lead coupler with a clamp.
- E To the ignition coil.
- F The end of the plastic locking tie should face towards the under the handlebar.
- G Fasten the right handlebar switch lead with a plastic locking tie.
- H Pass the right handlebar switch lead behind the upper bracket.
- I Fasten the brake hose grommet with a brake hose holder. (depending on model type)
- J Fasten the brake hose with a brake hose holder.
- K Pass the left handlebar switch lead under the main switch.
- L Fasten the spark plug lead with a metal clamp.
- M Pass the ignition coil lead inside of the starter cable.
- N Fasten the fuse box lead with a plastic locking tie.

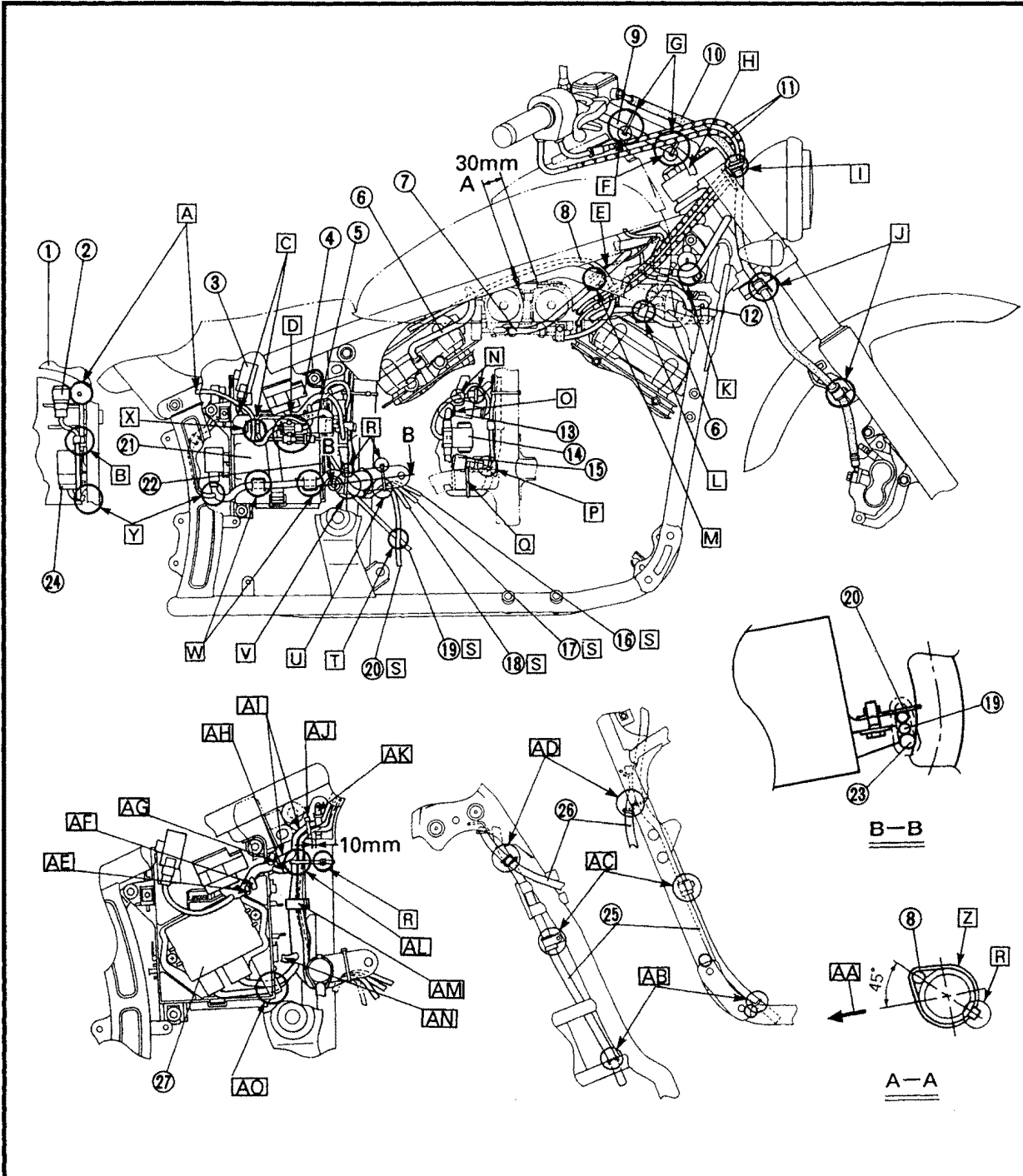



- Q Fasten the battery positive (+) lead with a battery box clamp.
- P The carburetor heater relay should not touch the wire harness.
- Q Fasten the wire harness with a plastic locking tie.
- R Place the end of the plastic locking tie as shown.
- S From the engine.
- T Pass the starter motor lead over the battery negative (-) lead.
- U Fasten the pickup coil lead, A.C. magneto lead, neutral switch lead and starter motor lead with

- a plastic locking tie.
- V Fasten the battery negative (-) lead, starter motor lead and wire harness with a plastic locking tie.
- W Fasten the wire harness with a clamp.
- X Fasten the battery negative (-) lead and tail/brake light lead with a clamp.
- Y Pass the wire harness between the frame and battery box.
- Z Fasten the starter cable with a plastic locking tie.

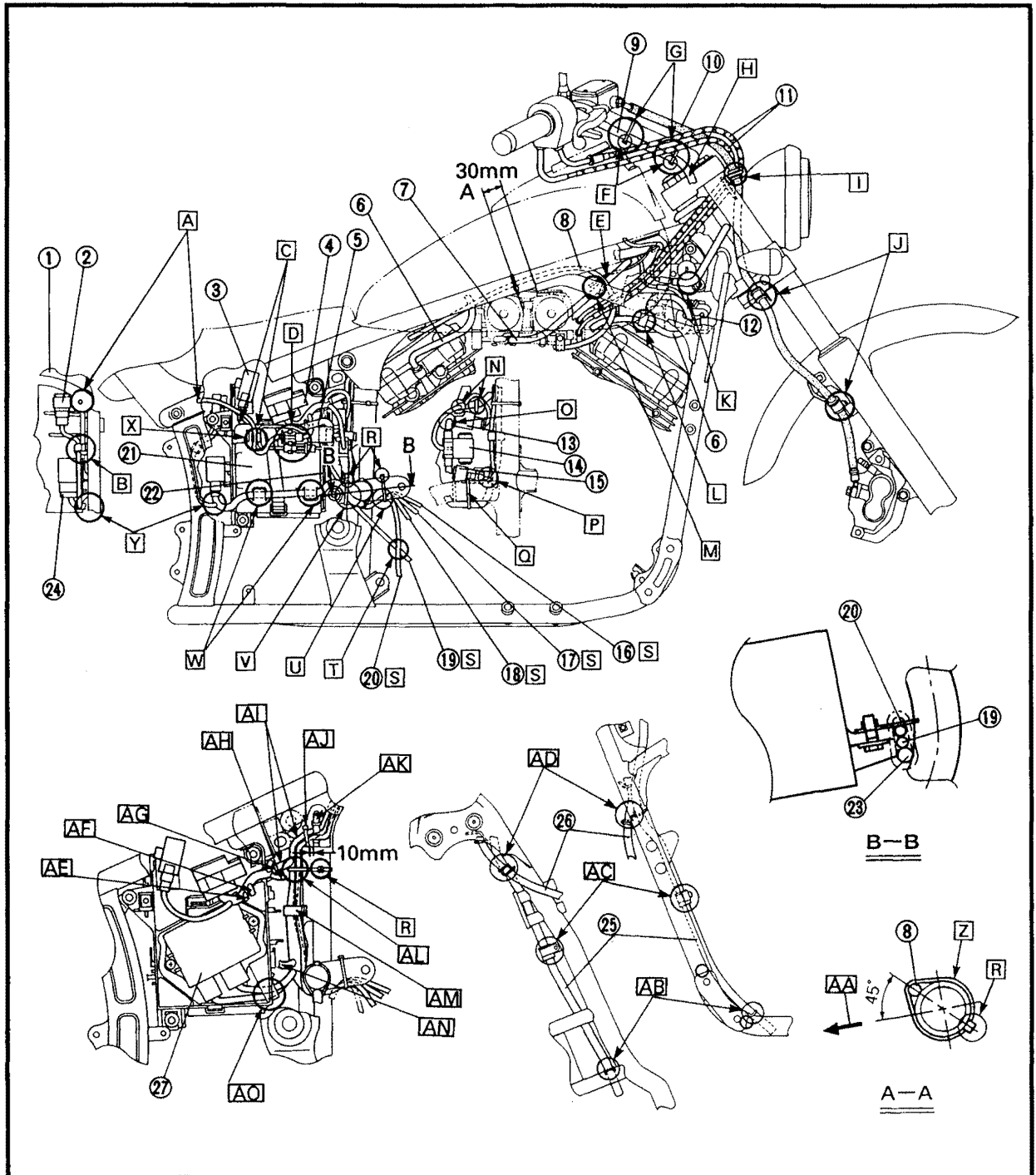



- AA** Inside the motorcycle.
- AB** Pass the fuel tank breather hose through the holder.
- AC** Fasten the fuel tank breather hose with a metal clamp.
- AD** Pass the speedometer cable through the front side guide.
- AE** To the battery negative (-) lead.
- AF** To the rear fender.
- AG** To the flasher light relay.
- AH** To the starter relay.
- AI** The wire harness and leads should not touch the rear shock absorber.
- AJ** Fasten the wire harness and leads with a plastic locking tie.
- AK** Pass the plastic band through the frame hole. Fasten the wire harness with a plastic band at the point where the tape is located.
- AL** Fasten the wire harness and leads with a plastic locking tie.
- AM** Fasten the wire harness and leads with a metal clamp.
- AN** To the carburetor heater relay.
- AO** Pass the ignitor unit leads through the battery box hole.

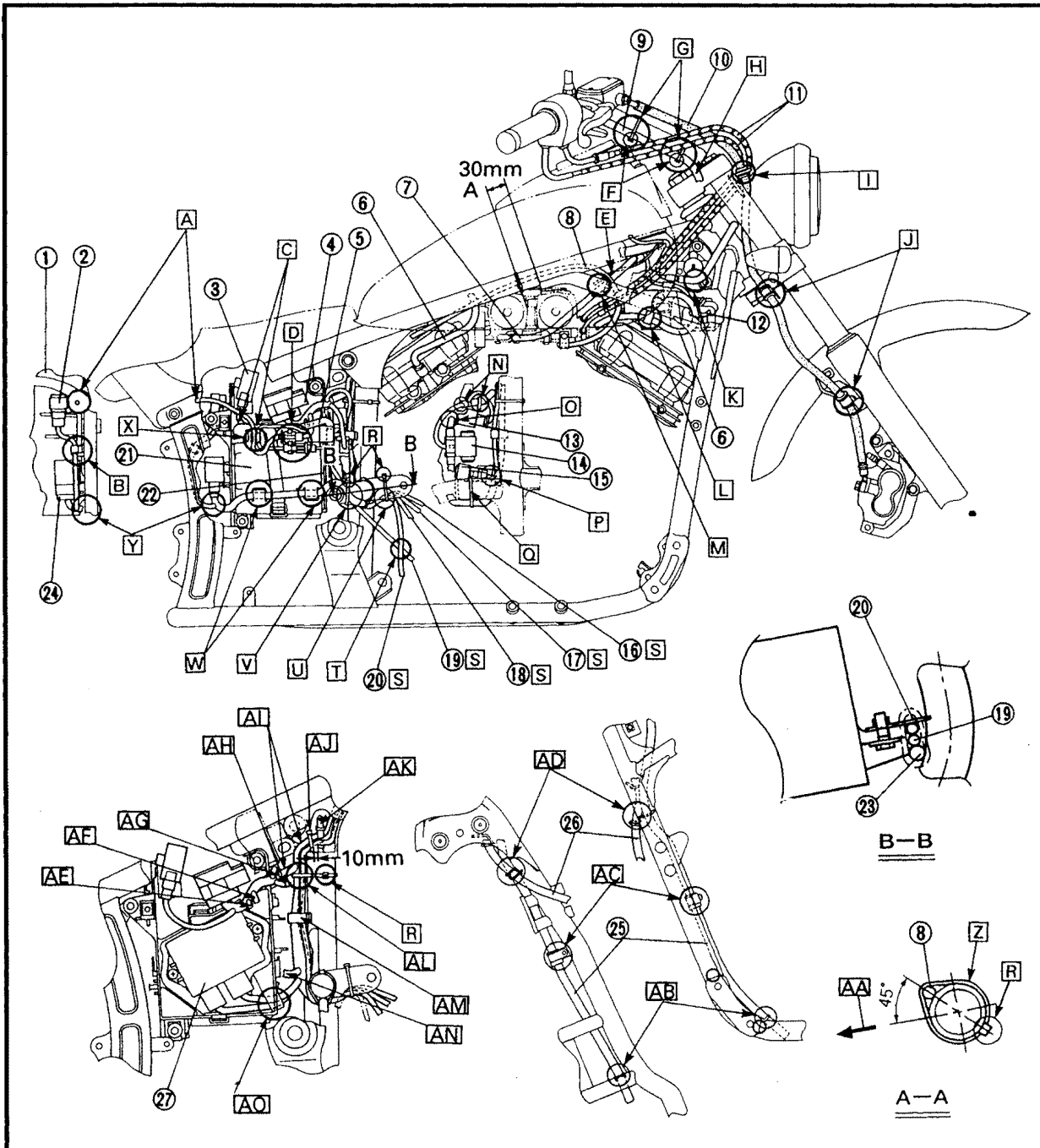



- | | | |
|-------------------------------|---------------------------------------|---|
| ① Front flasher light (right) | ⑫ Speedometer cable | Ⓐ Pass the throttle cables through the cable guide. |
| ② Throttle cables | ⑬ Neutral switch lead | Ⓑ Pass the left handlebar switch lead over the right handlebar switch lead. |
| ③ Brake hose | ⑭ Pickup coil lead | Ⓒ Pass the clutch cable through the cable guide. |
| ④ Right handlebar switch lead | ⑮ A.C. magneto lead | Ⓓ Fasten the handlebar switch leads with a plastic band. |
| ⑤ Clutch cable | ⑯ Thermo switch lead | Ⓔ To the ignition coil. |
| ⑥ Left handlebar switch lead | ⑰ Fuel tank breather hose | Ⓕ Pass the starter cable between the ignition coil and spark plug lead. |
| ⑦ Front flasher light (left) | ⑱ Wire harness | |
| ⑧ Ignition coil | ⑲ Throttle position sensor (TPS) lead | |
| ⑨ Spark plug lead | ⑳ Frame | |
| ⑩ Silencer | ㉑ Air filter case | |
| ⑪ Starter cable | | |

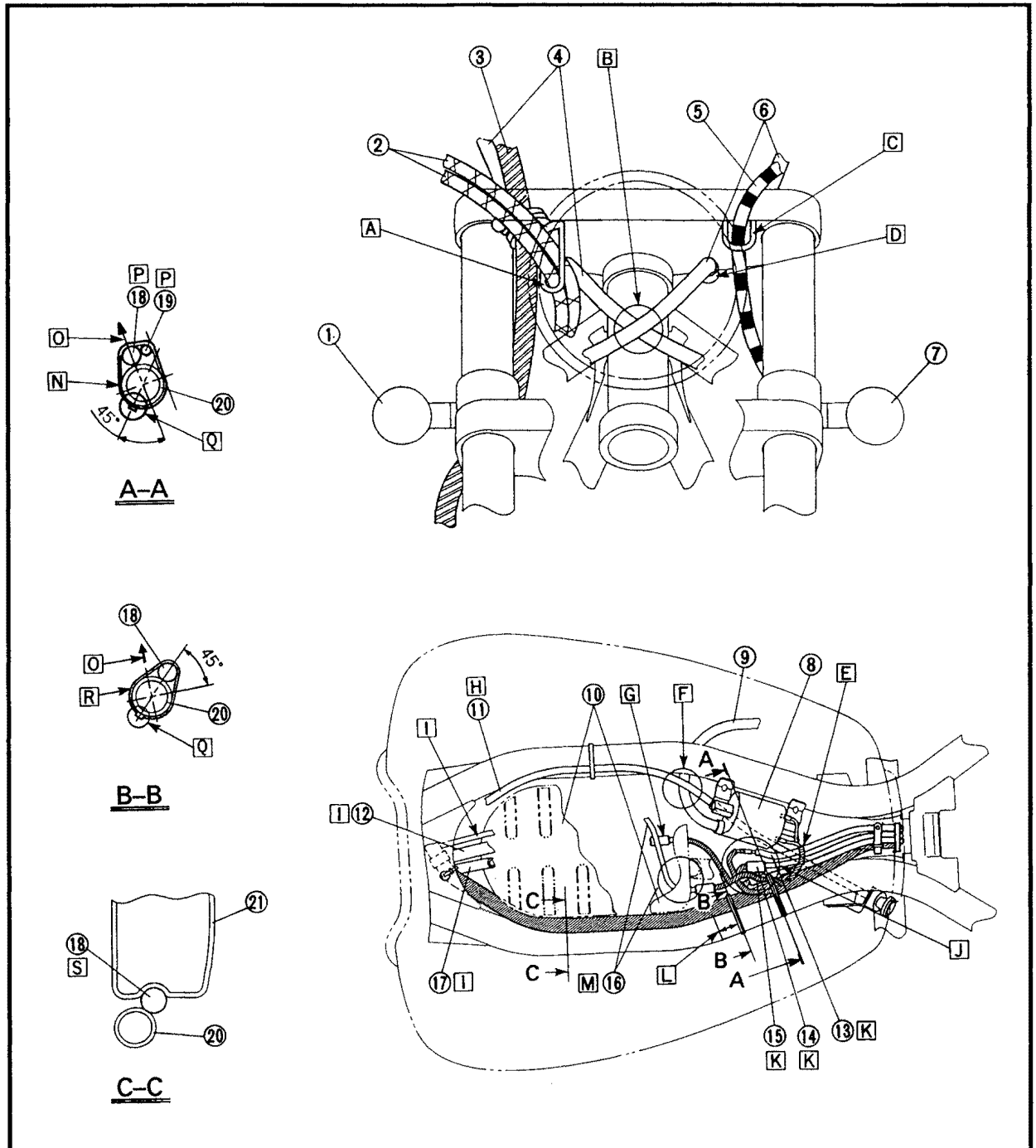



- G To the throttle position sensor (TPS).
- H To the carburetor.
- I To the fuel tank.
- J Pass the neutral switch lead, pickup coil lead and A.C. magneto lead under the ignition coil lead, thermo switch lead and throttle position sensor (TPS) lead.
- K From the engine.
- L 20 mm (0.79 in)
- M Pass the thermo switch lead inside of the silencer breather hose.
- N Fasten the wire harness and throttle position sensor (TPS) lead with a plastic locking tie.
- O Inside the motorcycle.
- P Route the wire harness and throttle position sensor (TPS) lead so they run along the bottom of the frame tube.
- Q Place the end of the plastic locking tie as shown.
- R Fasten the wire harness with a plastic locking tie.
- S Pass the wire harness between the air filter case groove and frame.

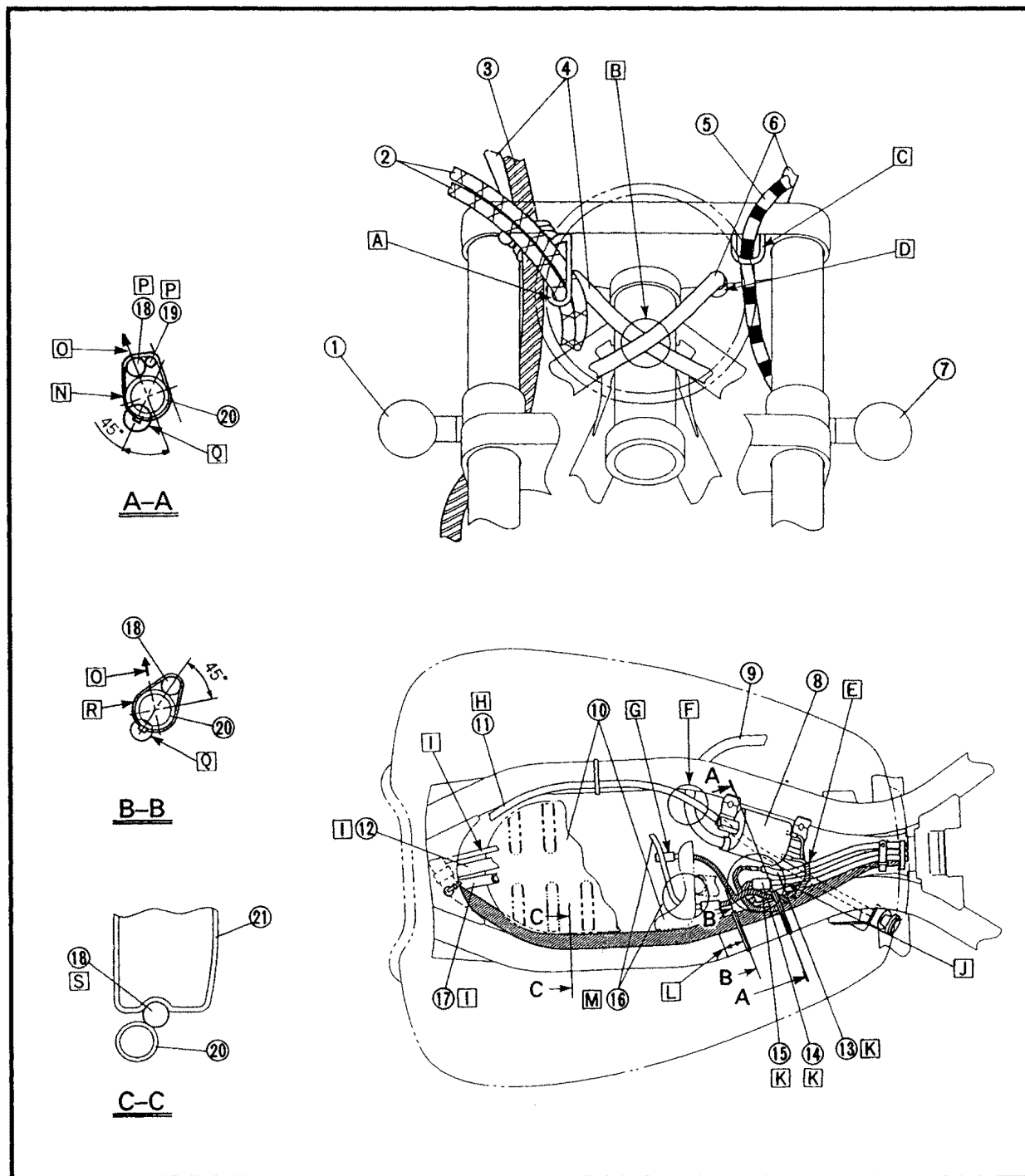

PERIODIC INSPECTION AND ADJUSTMENTS

FUEL TANK AND SEATS

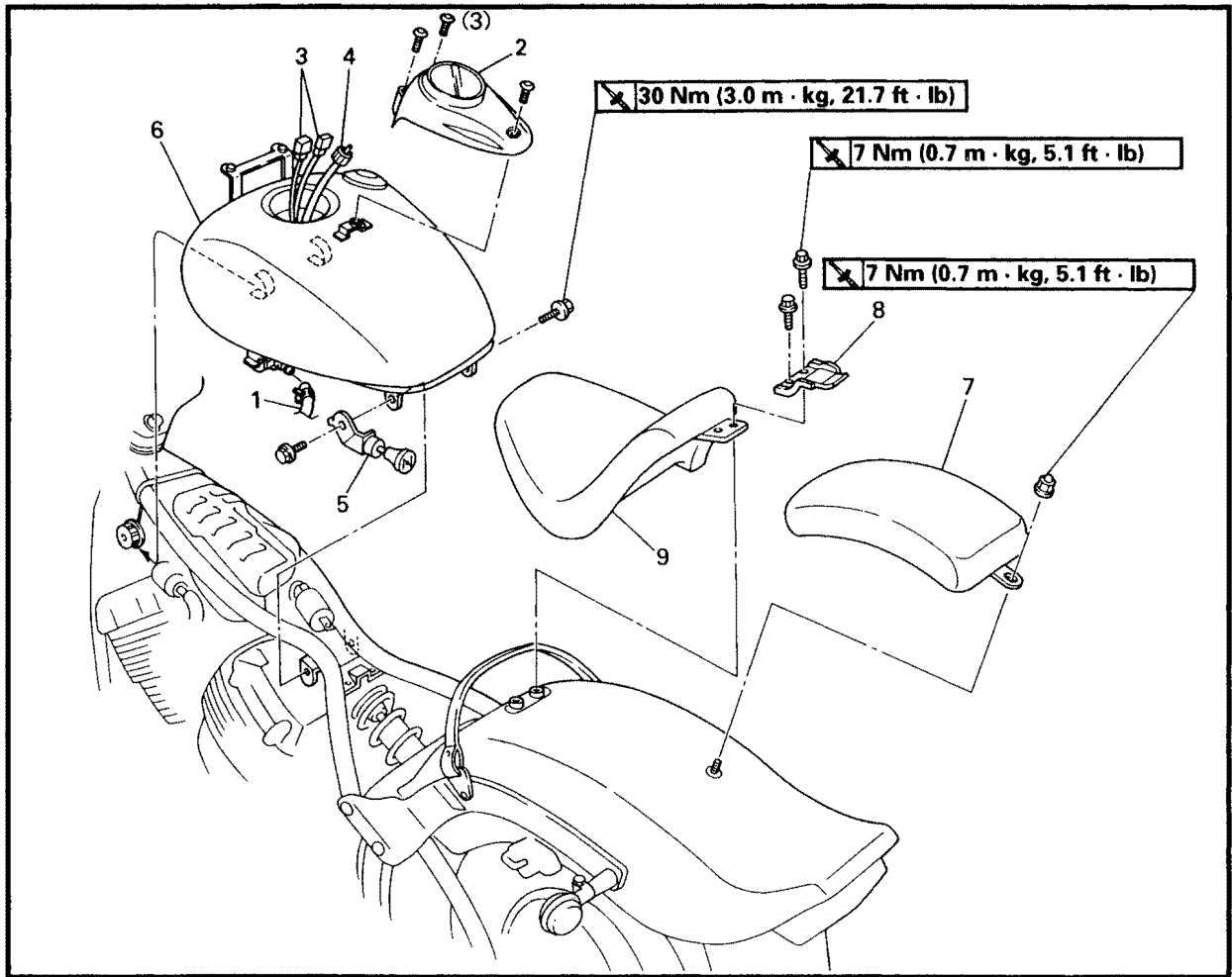

Order	Job name/Part name	Q'ty	Remarks
	Fuel tank and seats removal		Remove the parts in the order below.
1	Fuel hose	1	NOTE: _____ Set the fuel cock to "OFF" before disconnecting the fuel hose.
2	Meter assembly	1	
3	Meter lead coupler	2	
4	Speedometer cable	1	NOTE: _____ Disconnect the speedometer cable from the front wheel side first.
5	Starter knob bracket	1	
6	Fuel tank assembly	1	
7	Passenger seat	1	
8	Seat bracket	1	
9	Rider's seat	1	
			For installation, reverse the removal procedure.

HEADLIGHT BEAM ADJUSTMENT/ HEADLIGHT BULB REPLACEMENT

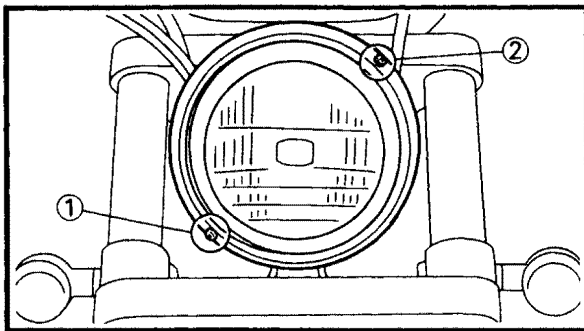

EB305020

HEADLIGHT BEAM ADJUSTMENT

1.Adjust:

- Headlight beam (vertically)
Turn the adjuster ① in or out.

Turning in:	headlight beam is raised.
Turning out:	headlight beam is lowered.

2.Adjust:

- Headlight beam (horizontally)
Turn the adjuster ② in or out.

Turning in:	headlight beam to the left.
Turning out:	headlight beam to the right.

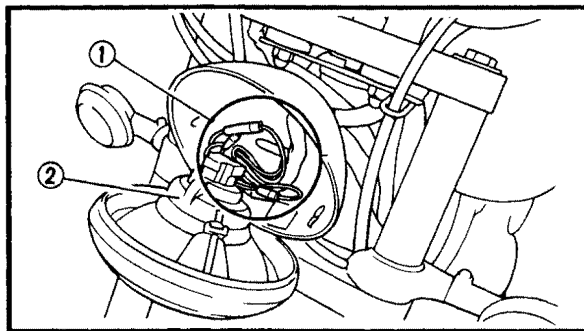

EB305030

HEADLIGHT BULB REPLACEMENT

1.Remove:

- Headlight lens unit

2.Disconnect:

- Leads (in headlight body) ①

3.Remove:

- Bulb cover ②

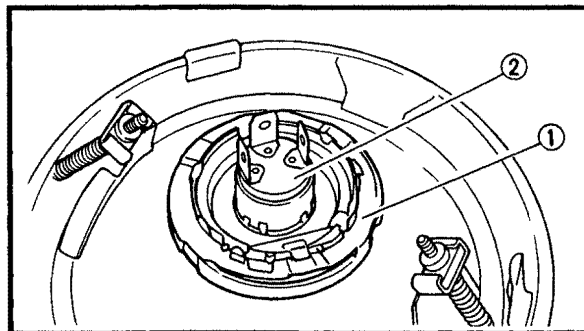

4.Unhook:

- Bulb holder ①

5.Remove:

- Bulb ②

⚠ WARNING

Since the bulb may be hot, keep flammable products and your hands away from it. Do not touch the bulb until it has cooled down.

6.Install:

- Bulb (new)

Secure the new bulb with the bulb holder.

CAUTION:

Avoid touching the glass part of the bulb. Keep it free from oil, otherwise the transparency of the glass, life of the bulb and the luminous flux will be adversely affected. If oil gets on the bulb, thoroughly clean it with a cloth moistened with alcohol or lacquer thinner.

7.Hook up:

- Bulb holder

8.Install:

- Bulb cover

9.Connect:

- Leads (in headlight body)

10.Install:

- Headlight lens unit

CHASSIS

FRONT FORK

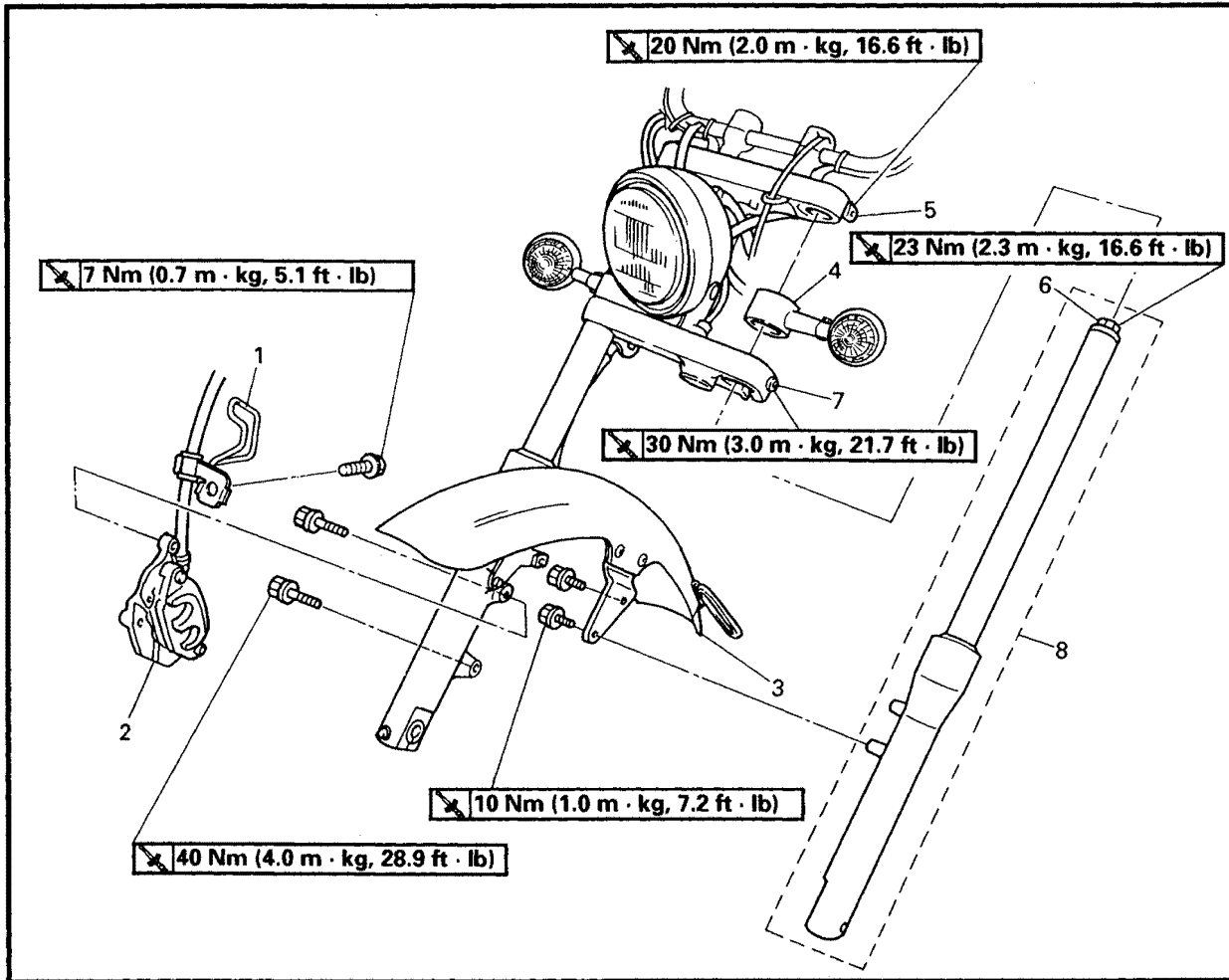

Order	Job name/Part name	Q'ty	Remarks
	Front fork removal		Remove the parts in the order below.
	Front wheel		Refer to "FRONT WHEEL".
1	Brake hose holder	1	
2	Brake caliper assembly	1	
3	Front fender	1	
4	Front flasher light holder nuts	2	
5	Upper bracket bolts	2	
6	Cap bolts	2	Loosen
7	Lower bracket bolts	2	Refer to "FRONT FORK INSTALLATION".
8	Front forks	2	
			For installation, reverse the removal procedure.

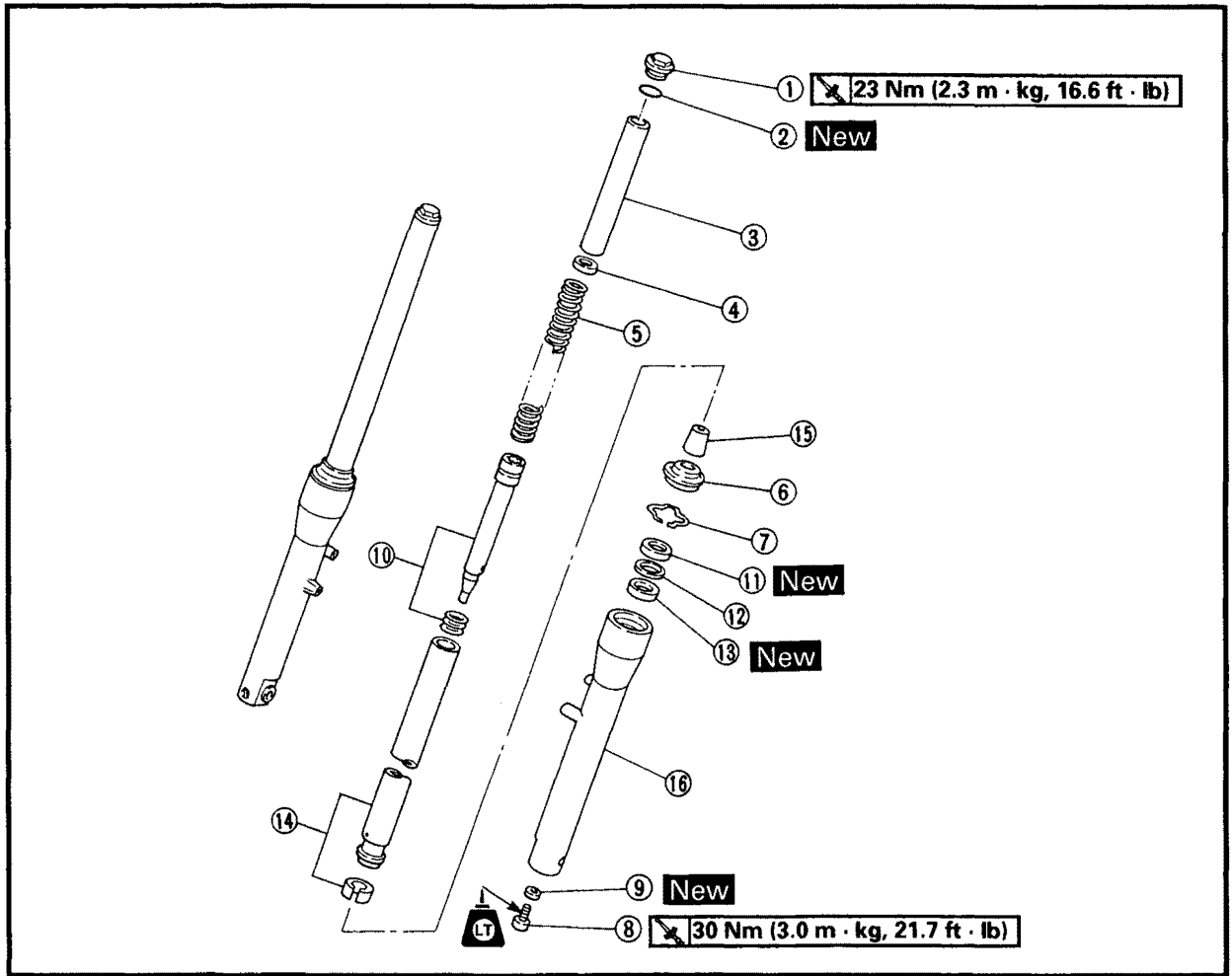

Order	Job name/Part name	Q'ty	Remarks	
	Front fork disassembly		Disassemble the parts in the order below.	
①	Cap bolt	1	Refer to "FRONT FORK ASSEMBLY".	
②	O-ring	1		
③	Spacer collar	1		
④	Spring seat	1		
⑤	Fork spring	1		
⑥	Dust seal	1		
⑦	Retaining clip	1		
⑧	Damper rod bolt	1		Refer to "FRONT FORK DISASSEMBLY/ASSEMBLY".
⑨	Gasket	1		
⑩	Damper rod/rebound spring	1/1		
⑪	Oil seal	1		

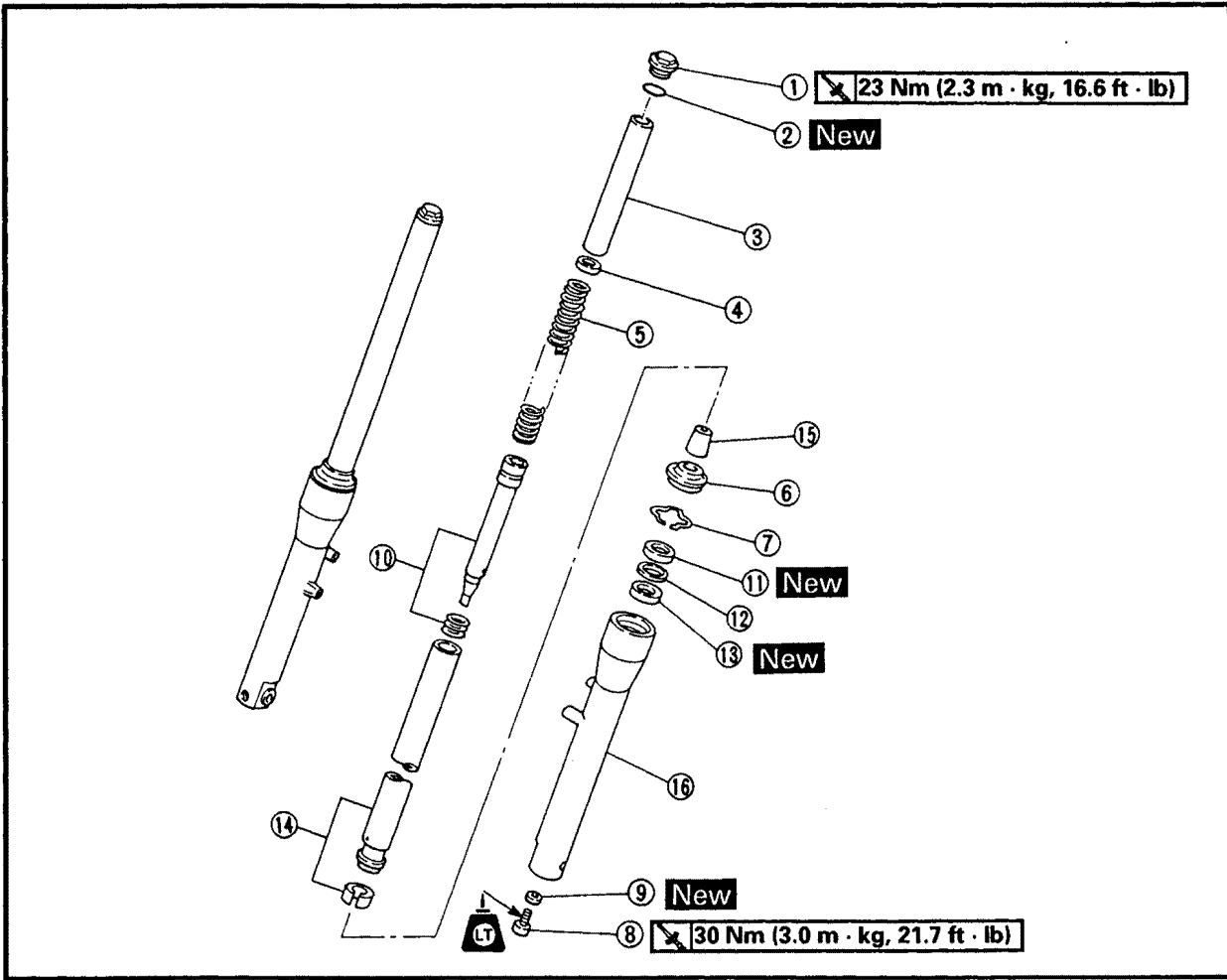

Order	Job name/Part name	Q'ty	Remarks
⑫	Seal spacer	1	Refer to "FRONT FORK ASSEMBLY".
⑬	Slide metal	1	
⑭	Inner tube/piston metal	1/1	
⑮	Oil lock piece	1	
⑯	Outer tube	1	
			For assembly, reverse the disassembly procedure.

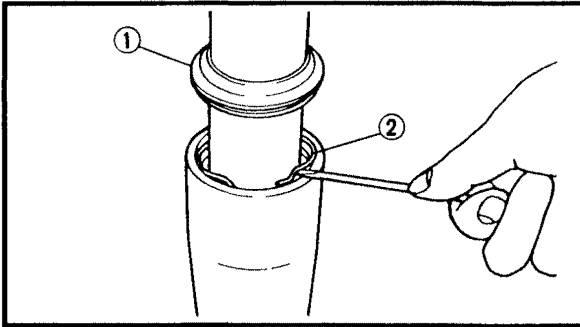

FRONT FORK DISASSEMBLY

1.Remove:

- Dust seal ①
- Retaining clip ②
(use a slotted-head screwdriver)

CAUTION: _____
Take care not to scratch the inner tube.

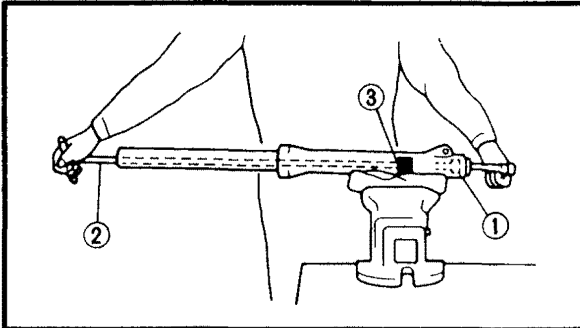

2.Remove:

- Damper rod bolt ①

NOTE: _____
 Loosen the damper rod bolt while holding the damper rod with the T-handle ② and the damper rod holder ③.

	<p>T-Handle: YM-01326, 90890-01326</p> <p>Damper rod holder: YM-01388, 90890-01388</p>
--	--

3.Remove:

- Damper rod
- Rebound spring

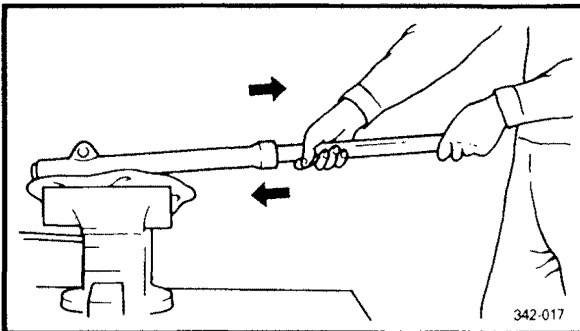

4.Remove

- Inner tube

Removal steps:

- Hold the fork leg horizontally.
- Securely clamp the caliper mounting boss of the outer tube in a vise with soft jaws.
- Separate the inner tube from the outer tube by pulling forcefully but carefully on the inner tube.

CAUTION: _____

- Excessive force will damage the oil seal and/or the slide metal. A damaged oil seal and metal must be replaced.
- Avoid bottoming the inner tube into the outer tube during the above procedure, as the oil lock piece will be damaged.

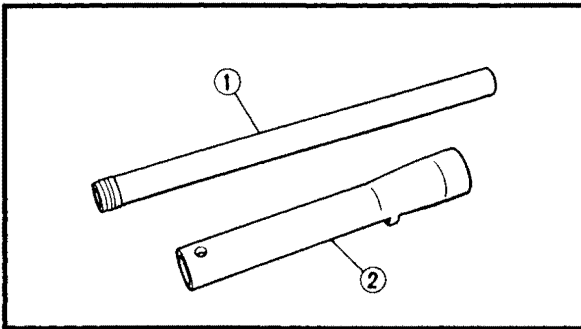

EB703030

FRONT FORK INSPECTION

1. Inspect:

- Inner tube ①
 - Outer tube ②
- Scratches/bends/damage → Replace.

⚠ WARNING

Do not attempt to straighten a bent inner tube as this may dangerously weaken the tube.

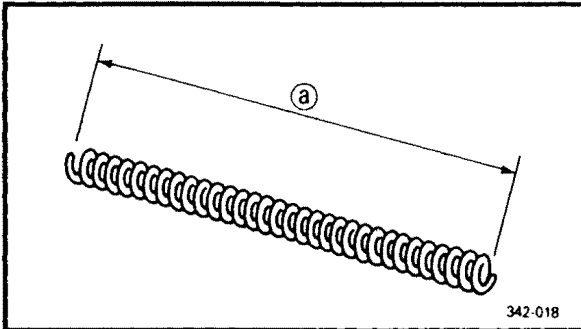

2. Measure:

- Fork spring length ③
- Over the specified limit → Replace.



**Fork spring free length (limit):
284 mm (11.18 in)**

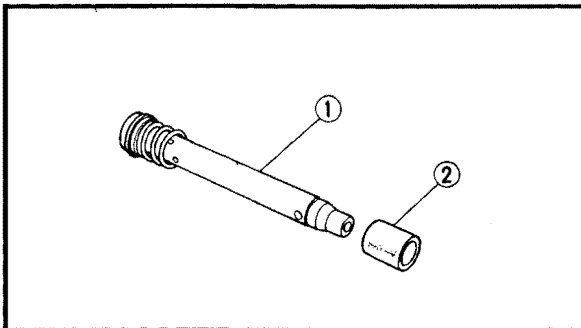

3. Inspect:

- Damper rod ①
- Wear/damage → Replace.
Contamination → Blow out all of the oil passages with compressed air.
- Oil lock piece ②
- Damage → Replace.

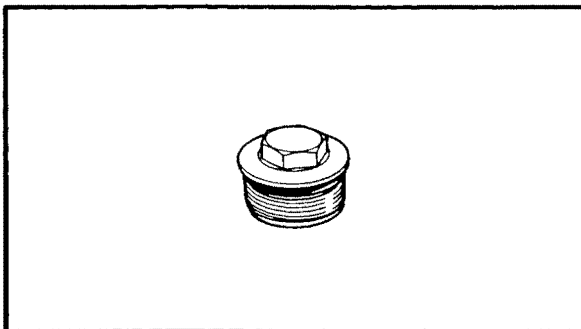

4. Inspect:

- O-ring (cap bolt)
- Wear/damage → Replace.

FRONT FORK ASSEMBLY**NOTE:**

- When reassembling the front fork, replace the following parts.
 - *Piston metal
 - *Slide metal
 - *Oil seal
 - *Dust seal
- Before reassembly make sure that all the components are clean.

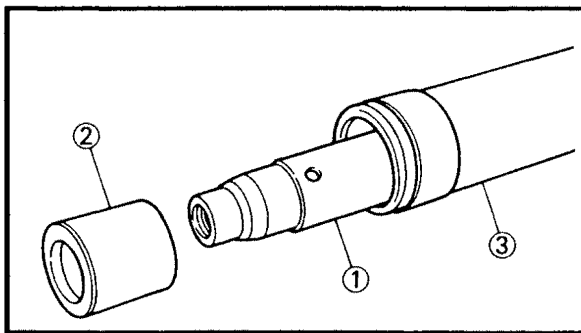

- 1.Install:
- Damper rod ①
 - Rebound spring
 - Oil lock piece ②
 - Inner tube ③

CAUTION:
 Allow the damper rod to slide slowly down the inner tube until it protrudes from the bottom, being careful not to damage the inner tube.

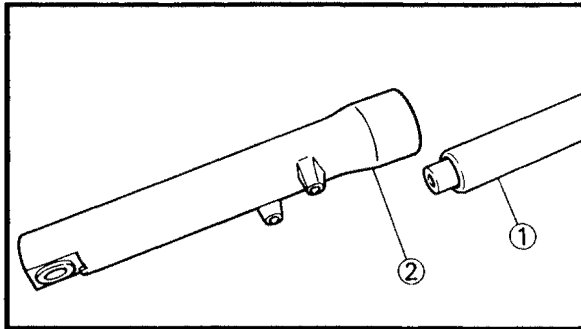

- 2.Lubricate:
- Inner tube (outer surface)

 **Recommended lubricant:**
 Yamaha fork oil 10WT or equivalent

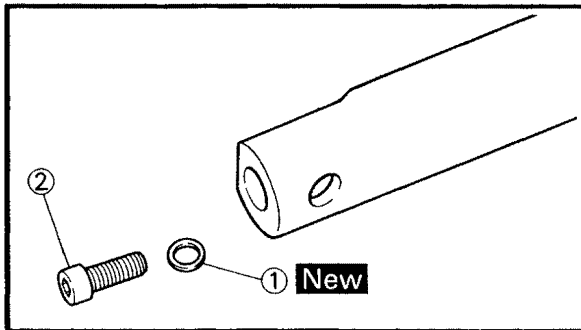

- 3.Install:
- Inner tube ①
 (to outer tube ②)

- 4.Install:
- Gasket ① **New**
 - Damper rod bolt ②

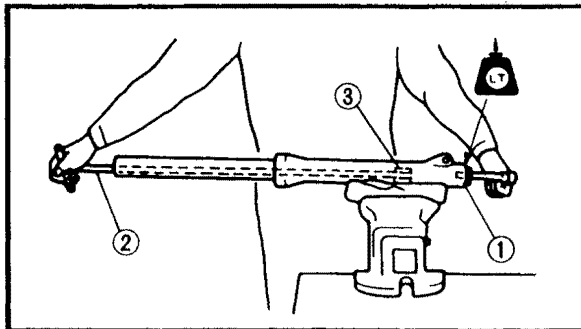

- 5.Tighten:
- Damper rod bolt ①
-  **30 Nm (3.0 m · kg, 21.7 ft · lb)**

NOTE:
 Apply LOCTITE® to the threads of the damper rod holder. Tighten the damper rod bolt while holding the damper rod with a T-handle ② and a damper rod holder ③.

 **T-handle:**
 YM-01326, 90890-01326
Damper rod holder:
 YM-01388, 90890-01388

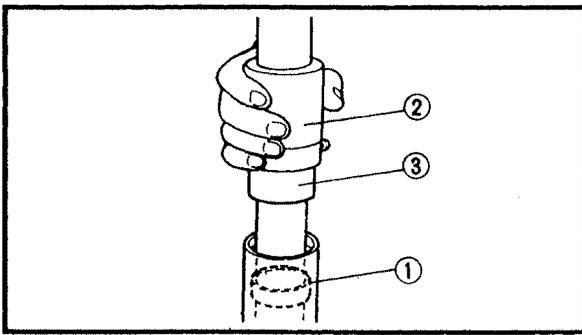

6.Install:

- Slide metal ① **New**
- Seal spacer

Use the fork seal driver weight ② and the adapter ③.

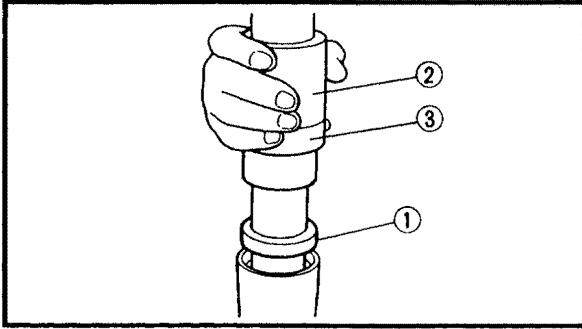

7.Install:

- Oil seal ① **New**

Use the fork seal driver weight ② and the adapter ③.



Fork seal driver weight:
YM-01326, 90890-01367
Adapter:
YM-01388, 90890-01381

NOTE:

Before installing the oil seal, apply lithium soap base grease onto the oil seal lips.

CAUTION:

Make sure that the numbered side of the oil seal faces up.

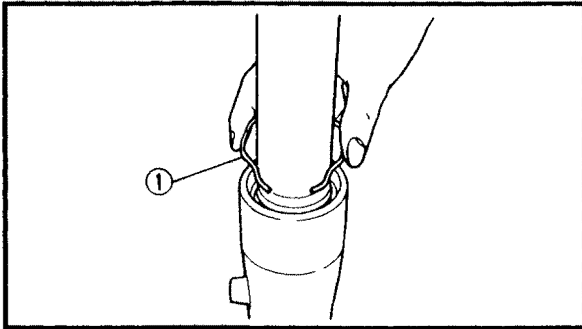

8.Install:

- Retaining clip ①

NOTE:

Adjust the retaining clip so that it fits into the outer tube groove.

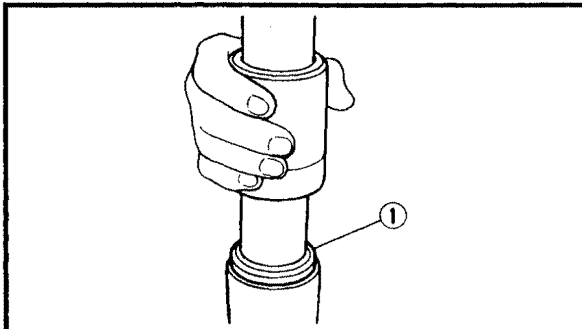

9.Install:

- Dust seal ①

Use the fork seal driver weight.



Fork seal driver weight:
YM-33963, 90890-01367

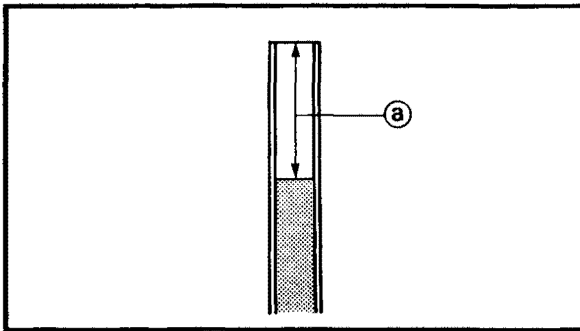

- 10.Fill:
 • Fork oil



Each fork:
 454 cm³ (15.9 Imp oz, 15.3 US oz)
 Yamaha fork oil 10WT or equivalent. After filling up, slowly pump the fork up and down to distribute the fork oil.
Oil level (a):
 114 mm (4.49 in)
 (from the top of the inner tube fully compressed and without the fork spring)

NOTE: _____
 Hold the fork in an upright position.

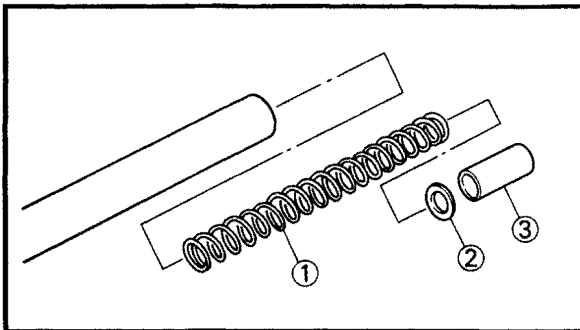

- 11.Install:
 • Fork spring ①
 • Spring seat ②
 • Spacer collar ③
 • O-ring
 • Cap bolt

NOTE: _____
 • Before installing the cap bolt, apply grease to the O-ring.
 • Temporarily tighten the cap bolt.

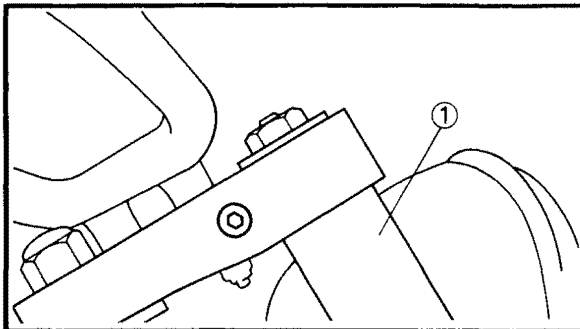

FRONT FORK INSTALLATION

- 1.Install:
 • Front forks ①

NOTE: _____
 Make sure that the inner tube end is flush with the top of the upper bracket.

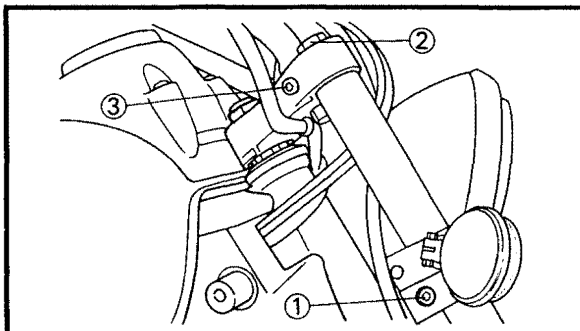

- 2.Tighten:
 • Lower bracket bolts ①

	30 Nm (3.0 m · kg, 21.7 ft · lb)
---	----------------------------------

 • Cap bolts ②

	23 Nm (2.3 m · kg, 17 ft · lb)
---	--------------------------------

 • Upper bracket bolts ③

	20 Nm (2.0 m · kg, 17 ft · lb)
---	--------------------------------

STEERING HEAD

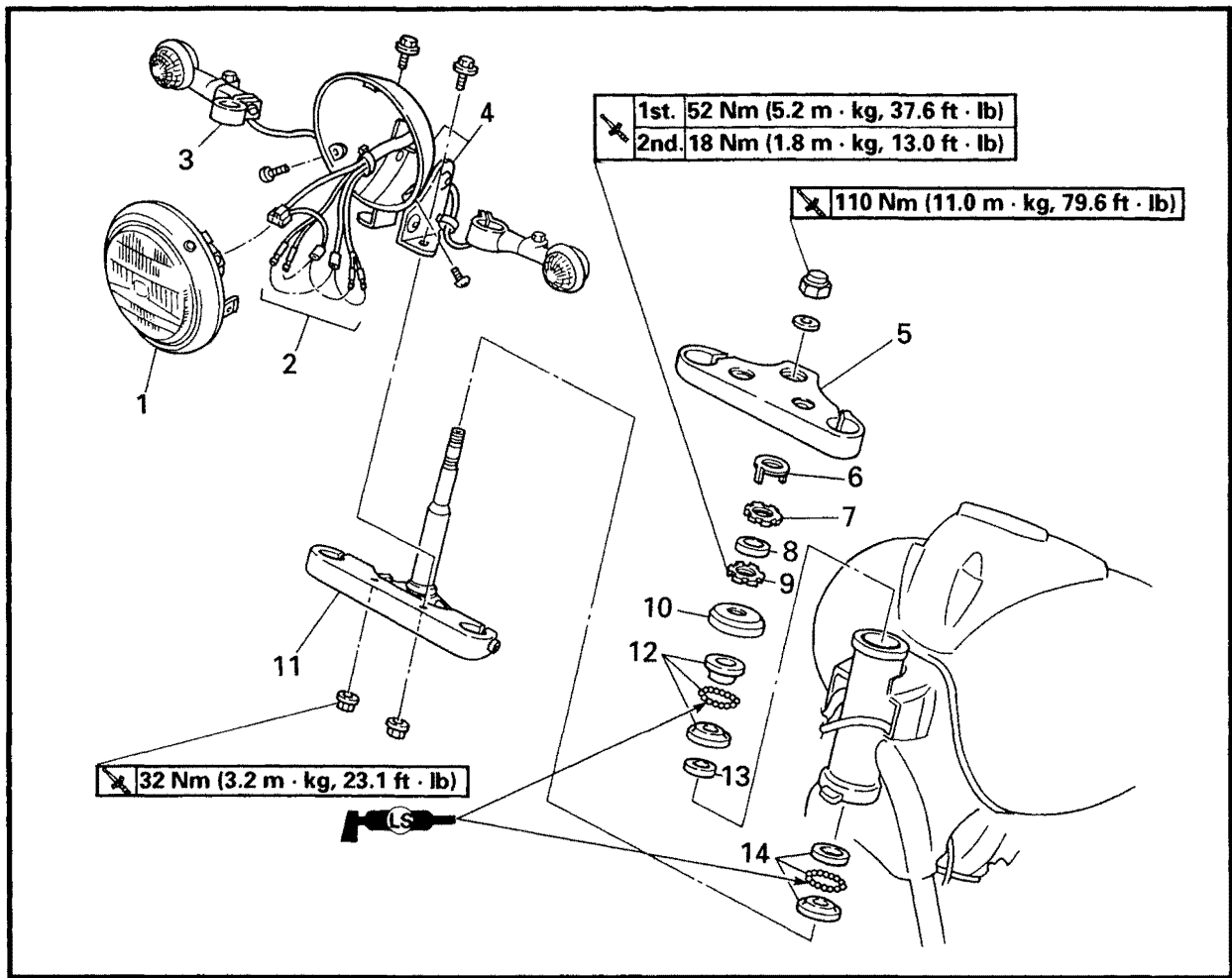

Order	Job name/Part name	Q'ty	Remarks
	Steering head removal		Remove the parts in the order below. Stand the motorcycle on a level surface.
			⚠ WARNING Securely support the motorcycle so that there is no danger of it falling over.
	Front forks		Refer to "FRONT FORK".
	Handlebar		Refer to "HANDLEBAR".
1	Headlight lens unit	1	
2	Leads (in the headlight body)	-	Disconnect
3	Front flasher light (left/right)	1/1	
4	Headlight body	1	
5	Upper bracket	1	
6	Lock washer	1	
7	Upper ring nut	1	

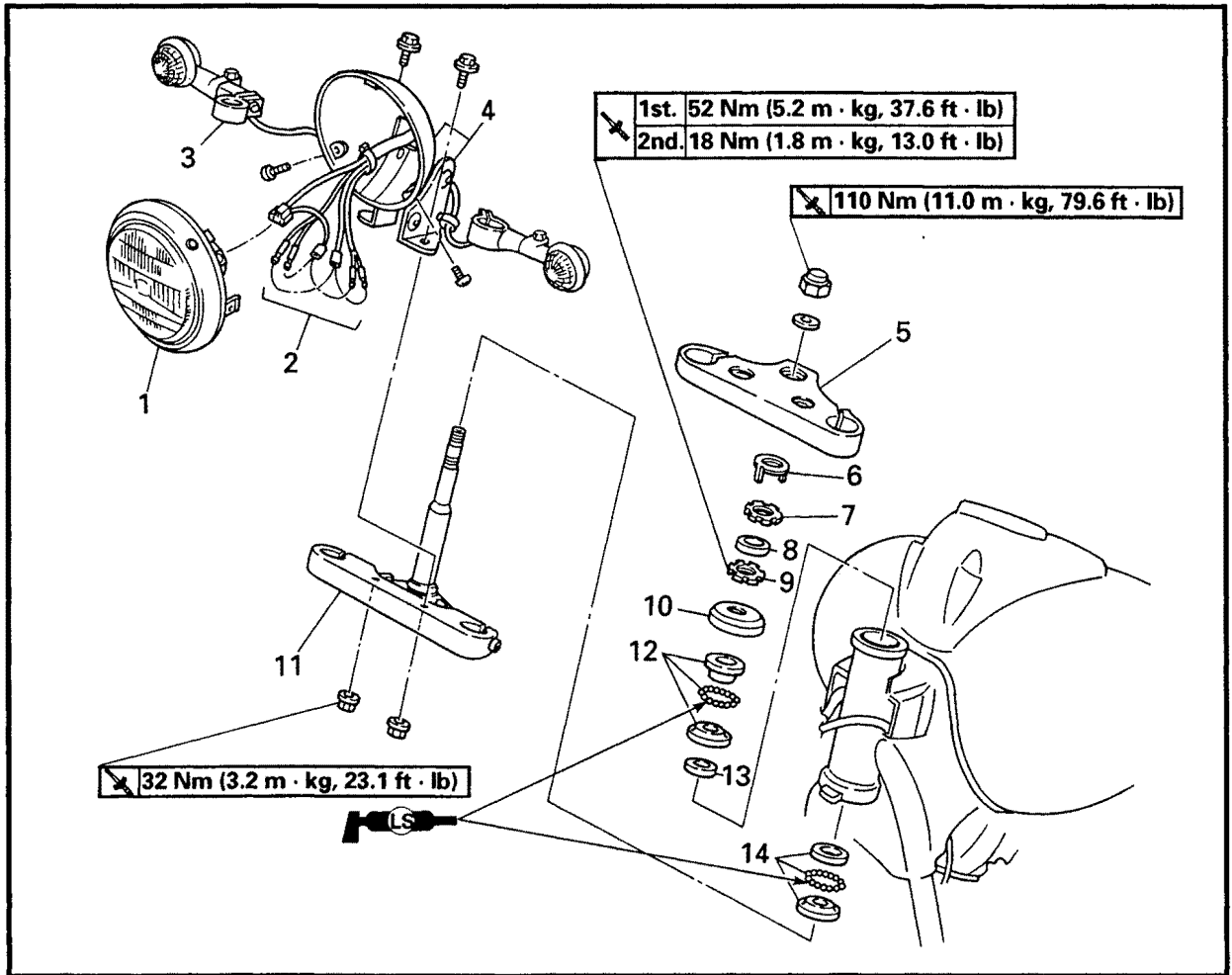

Order	Job name/Part name	Q'ty	Remarks
8	Rubber washer	1	Refer to "STEERING HEAD REMOVAL/INSTALLATION".
9	Lower ring nut	1	
10	Bearing cover	1	
11	Lower bracket	1	
12	Bearing (upper)	1	
13	Rubber seal	1	
14	Bearing (lower)	1	
			For installation, reverse the removal procedure.

YAMAHA

YAMAHA MOTOR CO., LTD.

Printed in USA

PROTECT YOUR INVESTMENT
Use Genuine YAMAHA Parts And Accessories



LIT-11616-XV-00

YAMAHA MOTOR CORPORATION, U.S.A.
PRINTED IN U.S.A.