

# USER MANUAL

DGS-2208

VERSION 3.1



# Table of Contents

<b>Safety Instructions .....</b>	<b>3</b>	<b>Networking Basics .....</b>	<b>24</b>
Safety Cautions .....	3	Check your IP address .....	24
Protecting Against Electrostatic Discharge.....	6	Windows® XP/2000 Users.....	24
<b>Product Overview .....</b>	<b>7</b>	Windows Vista™ Users.....	24
Package Contents .....	7	Statically Assign an IP address .....	25
Setup .....	7	Windows® XP/2000 Users.....	25
Introduction.....	8	Windows Vista™ Users.....	26
Features .....	11	<b>Technical Specifications.....</b>	<b>27</b>
Hardware Overview .....	12	DGS-2208 Specifications .....	27
Front Panel (LEDs) .....	12	<b>Contacting Technical Support .....</b>	<b>29</b>
Rear Panel (Connections) .....	14	<b>Warranty.....</b>	<b>30</b>
<b>Installation.....</b>	<b>15</b>	<b>Registration.....</b>	<b>35</b>
Before You Connect to the Network .....	15		
Mounting the Switch on the Wall .....	16		
Mounting on a cement wall .....	16		
Mounting on a wood wall .....	16		
Connecting the Switch.....	17		
DGS-2208 to End Node .....	17		
Hub/Switch to DGS-2208.....	17		
Connecting To Network Backbone or Server ..	17		
<b>Troubleshooting .....</b>	<b>18</b>		
<b>Glossary .....</b>	<b>19</b>		

# Safety Instructions

Use the following safety guidelines to ensure your own personal safety and to help protect your system from potential damage.

## Safety Cautions

To reduce the risk of bodily injury, electrical shock, fire, and damage to the equipment, observe the following precautions.

Observe and follow service markings. Do not service any product except as explained in your system documentation. Opening or removing covers that are marked with the triangular symbol with a lightning bolt may expose you to an electrical shock. Only a trained service technician should service components inside these compartments.

If any of the following conditions occur, unplug the product from the electrical outlet and replace the part or contact your trained service provider:

- The power cable, extension cable, or plug is damaged.
  - An object has fallen into the product.
  - The product has been exposed to water.
  - The product has been dropped or damaged.
  - The product does not operate correctly when you follow the operating instructions.
- Keep your system away from radiators and heat sources. Also, do not block cooling vents.
  - Do not spill food or liquids on your system components, and never operate the product in a wet environment. If the system gets wet, see the appropriate section in your troubleshooting guide or contact your trained service provider.

- Do not push any objects into the openings of your system. Doing so can cause a fire or an electric shock by shorting out interior components.
- Use the product only with approved equipment.
- Allow the product to cool before removing covers or touching internal components.
- Operate the product only from the type of external power source indicated on the electrical ratings label. If you are not sure of the type of power source required, consult your service provider or local power company.
- To help avoid damaging your system, be sure the voltage selection switch (if provided) on the power supply is set to match the power available at your location:
  - 115 volts (V)/60 hertz (Hz) in most of North and South America and some Far Eastern countries such as South Korea and Taiwan.
  - 100 V/50 Hz in eastern Japan and 100 V/60 Hz in western Japan.
  - 230 V/50 Hz in most of Europe, the Middle East, and the Far East.
- Also be sure that attached devices are electrically rated to operate with the power available in your location.
- Use only approved power cable(s). If you have not been provided with a power cable for your system or for any AC-powered option intended for your system, purchase a power cable that is approved for use in your country. The power cable must be rated for the product and for the voltage and current marked on the product's electrical ratings label. The voltage and current rating of the cable should be greater than the ratings marked on the product.
- To help prevent an electric shock, plug the system and peripheral power cables into properly grounded electrical outlets. These cables are equipped with three-prong plugs to help ensure proper grounding. Do not use adapter plugs or remove the grounding prong from a cable. If you must use an extension cable, use a 3-wire cable with properly grounded plugs.

- Observe extension cable and power strip ratings. Make sure that the total ampere rating of all products plugged into the extension cable or power strip does not exceed 80 percent of the ampere ratings limit for the extension cable or power strip.
- To help protect your system from sudden, transient increases and decreases in electrical power, use a surge suppressor, line conditioner, or uninterruptible power supply (UPS).
- Position system cables and power cables carefully; route cables so that they cannot be stepped on or tripped over. Be sure that nothing rests on any cables.
- Do not modify power cables or plugs. Consult a licensed electrician or your power company for site modifications. Always follow your local/national wiring rules.
- When connecting or disconnecting power to hot-pluggable power supplies, if offered with your system, observe the following guidelines:
  - Install the power supply before connecting the power cable to the power supply.
  - Unplug the power cable before removing the power supply.
  - If the system has multiple sources of power, disconnect power from the system by unplugging all power cables from the power supplies.
- Move products with care; ensure that all casters and/or stabilizers are firmly connected to the system. Avoid sudden stops and uneven surfaces.

# Protecting Against Electrostatic Discharge

Static electricity can harm delicate components inside your system. To prevent static damage, discharge static electricity from your body before you touch any of the electronic components, such as the microprocessor. You can do so by periodically touching an unpainted metal surface on the chassis.

You can also take the following steps to prevent damage from electrostatic discharge (ESD):

1. When unpacking a static-sensitive component from its shipping carton, do not remove the component from the antistatic packing material until you are ready to install the component in your system. Just before unwrapping the antistatic packaging, be sure to discharge static electricity from your body.
2. When transporting a sensitive component, first place it in an antistatic container or packaging.
3. Handle all sensitive components in a static-safe area. If possible, use antistatic floor pads, workbench pads, and an antistatic grounding strap.

# Package Contents

- D-Link DGS-2208 8-port Switch
- Manual and Warranty on CD
- Four (4) Rubber Feet
- Wall Mount Kit
- Power Adapter



## Setup

The setup of the DGS-2208 can be performed using the following steps:

- The power outlet should be within 1.82 meters (6 feet) of the Switch.
- Visually inspect the DC power jack and make sure that it is fully secured to the power adapter.
- Do not cover the ventilation holes on the sides of the Switch, and make sure there is adequate ventilation around it.
- Do not place heavy objects on the switch.



# Introduction

## **D-Link Green Ethernet Technology**

D-Link Green Ethernet Technology implements special power-saving features under speed at 1000Mbps that detect cable length and link status and adjust power usage accordingly.

Green Ethernet Technology saves energy in two specific ways:

1. If there is no link on a port (when there is no connection or the device connected is turned off) the port(s) will enter a “sleep mode” which will drastically reduce the amount of power used.
2. D-Link Green Ethernet Technology detects the length of connected Ethernet cable and adjusts power usage accordingly without affecting performance. This way, a port connected to a 10m cable only uses as much power as it needs, instead of using full power, which is only needed for 100m cables.

## **Fast Ethernet Technology**

The growing importance of LANs and the increasing complexity of desktop computing applications are fueling the need for high performance networks. 100BASE-TX (Fast Ethernet) provides a cost-effective and high-performance solution for small workgroups, SMBs (Small to Medium Businesses), and any network supporting bandwidth-intensive applications. Fast Ethernet technology operates at 10 times the speed of traditional Ethernet, offering maximum performance and enhanced capability for existing Ethernet-based networks.

100Mbps Fast Ethernet is a standard specified by the IEEE 802.3 LAN committee. It is an extension of the 10Mbps Ethernet standard with the ability to transmit and receive data at 100Mbps, while maintaining the CSMA/CD Ethernet protocol. Since the 100Mbps Fast Ethernet is compatible with all other 10Mbps Ethernet environments, it provides a straightforward upgrade and takes advantage of the existing investment in hardware, software, and personnel training.



## **Gigabit Ethernet Technology**

Gigabit Ethernet is an extension of IEEE 802.3 Ethernet utilizing the same packet structure, format, and support for CSMA/CD protocol, full duplex, flow control, and management objects, but with a tenfold increase in theoretical throughput over 100Mbps Fast Ethernet and a one hundred-fold increase over 10Mbps Ethernet. Since it is compatible with all 10Mbps and 100Mbps Ethernet environments, Gigabit Ethernet provides a straightforward upgrade without wasting a company's existing investment in hardware, software, and trained personnel.

The increased speed and extra bandwidth offered by Gigabit Ethernet are essential to coping with the network bottlenecks that frequently develop as computers and their busses get faster and more users use applications that generate more traffic. Upgrading key components, such as your backbone and servers to Gigabit Ethernet can greatly improve network response times as well as significantly speed up the traffic between your subnetworks.

Gigabit Ethernet enables fast optical fiber connections to support video conferencing, complex imaging, and similar data-intensive applications. Likewise, since data transfers occur 10 times faster than Fast Ethernet, servers outfitted with Gigabit Ethernet NIC's are able to perform 10 times the number of operations in the same amount of time.

In addition, the phenomenal bandwidth delivered by Gigabit Ethernet is the most cost-effective method to take advantage of today and tomorrow's rapidly improving switching and routing internetworking technologies.

## **Switching Technology**

Switching is a cost-effective way of increasing the total network capacity available to users on a LAN. If an Ethernet network begins to display symptoms of congestion, low throughput, slow response times, and high rates of collision, installing a switch to a network can preserve much or all of the existing network's cabling and workstation interface card infrastructure, while still greatly enhancing the throughput for users. A switch is a viable solution even if demanding applications, such as multimedia production and video conferencing, are on the horizon. The most promising techniques, as well as the best return on investment, could well consist of installing the right mixture of Ethernet switches.

A switch increases capacity and decreases network loading by dividing a local area network into different LAN segments. Dividing a LAN into multiple segments is one of the most common ways of increasing available bandwidth. If segmented correctly, most network traffic will remain within a single segment, enjoying the full-line speed bandwidth of that segment.

Switches provide full-line speed and dedicated bandwidth for all connections. This is in contrast to hubs, which use the traditional shared networking topology, where the connected nodes contend for the same network bandwidth. When two switching nodes are communicating, they are connected with a dedicated channel between them, so there is no contention for network bandwidth with other nodes. As a result, the switch reduces considerably, the likelihood of traffic congestion.

For Ethernet networks, a switch is an effective way of eliminating the problem of chaining hubs beyond the “two-repeater limit.” A switch can be used to split parts of the network into different collision domains, making it possible to expand your Ethernet network beyond the 205-meter network diameter limit for 100BASE-TX networks. Switches supporting both 10Mbps Ethernet and 100Mbps Fast Ethernet are also ideal for bridging between existing 10Mbps networks and newer 100Mbps networks.

Switching LAN technology is a marked improvement over the previous generation of network hubs and bridges, which were characterized by higher latencies. Routers have also been used to segment local area networks, but the cost of a router, the setup and maintenance required, make routers relatively impractical. Today switches are an ideal solution to most kinds of local area network congestion problems.

### **802.1p Priority Tagging**

802.1p places a tag in a frame to indicate the priority of the frame. A tag will represent a priority of 0-7 and an 802.1p compliant switch can read this tag and prioritize traffic accordingly. In 802.1p a port can receive frames with varying priority tags and classify them based on these tags. A VoIP phone that supports 802.1p can assign a priority to its VoIP traffic and when it enters the switch the switch can give it a higher priority so that voice traffic is always clear and jitter free. The DGS-2208 supports the 802.1p feature with 4 preconfigured priority queues. When a frame tagged with an 802.1p priority bit is received by the switch it places the frame into one of 4 queues prioritized according to its tag number. For example, traffic tagged with a priority bit of 7 will have a higher priority than traffic tagged with a priority bit of 6 and so forth.

### **Jumbo Frame Support**

The DGS-2208 switch supports Jumbo Frames up to (9720 Bytes) in size. Jumbo Frame support is designed to improve network throughput and significantly reduce the CPU utilization of large file transfers such as multimedia files or large data files by enabling more efficient larger payloads per packet.

# Features

The DGS-2208 8-port 10/100/1000BASE-T Gigabit Ethernet Switch was designed for easy installation and high performance in an environment where traffic on the network and the number of users increase continuously.

- D-Link's "Green Ethernet" Technology
- Eight (8) 10/100/1000BASE-T Gigabit Ethernet ports
- Supports Auto-Negotiation for 10/100/1000Mbps and duplex mode
- Supports Auto-MDI/MDIX for each port
- Supports Full/Half duplex transfer mode for 10 and 100Mbps
- Supports Full-duplex transfer mode for 1000Mbps
- Supports IEEE 802.1p Priority Queuing, up to 4 queues
- Full wire speed reception and transmission
- Store-and-Forward switching method
- Supports 4K MAC addresses
- Extensive front-panel diagnostic LEDs
- Jumbo frame support (9720 Bytes in 1000Mbps only)
- IEEE 802.3x flow control for full duplex
- Back pressure flow control for half duplex

# Hardware Overview

## Front Panel (LEDs)



The LED indicators of the Switch include Power, 100/1000Mbps, and Link/Act. The following shows the LED indicators for the Switch along with an explanation of each indicator.

### **LED Indicators:**

Comprehensive LED indicators display the conditions of the Switch and status of the network. A description of these LED indicators follows (see LED Indicators). The LED indicators of the Switch include Power, Link/Act, 1000Mbps, and 100Mbps.

### **Power Indicator**

This green indicator illuminates when the Switch is receiving power.

### **Link/Act**

This green indicator illuminates steadily when a port is connected to a station successfully and has a good link. The indicator will blink to indicate that a port is transmitting or receiving data on the network.

### **Speed – 1000Mbps/Green; 100Mbps/Amber; 10Mbps/Off**

This indicator is amber-colored when the port is connected to a 100Mbps Fast Ethernet station. It is green when the port is connected to a 1000Mbps Ethernet station. It is not illuminated when the port is connected to a 10Mbps Ethernet station.

## Rear Panel (Connections)

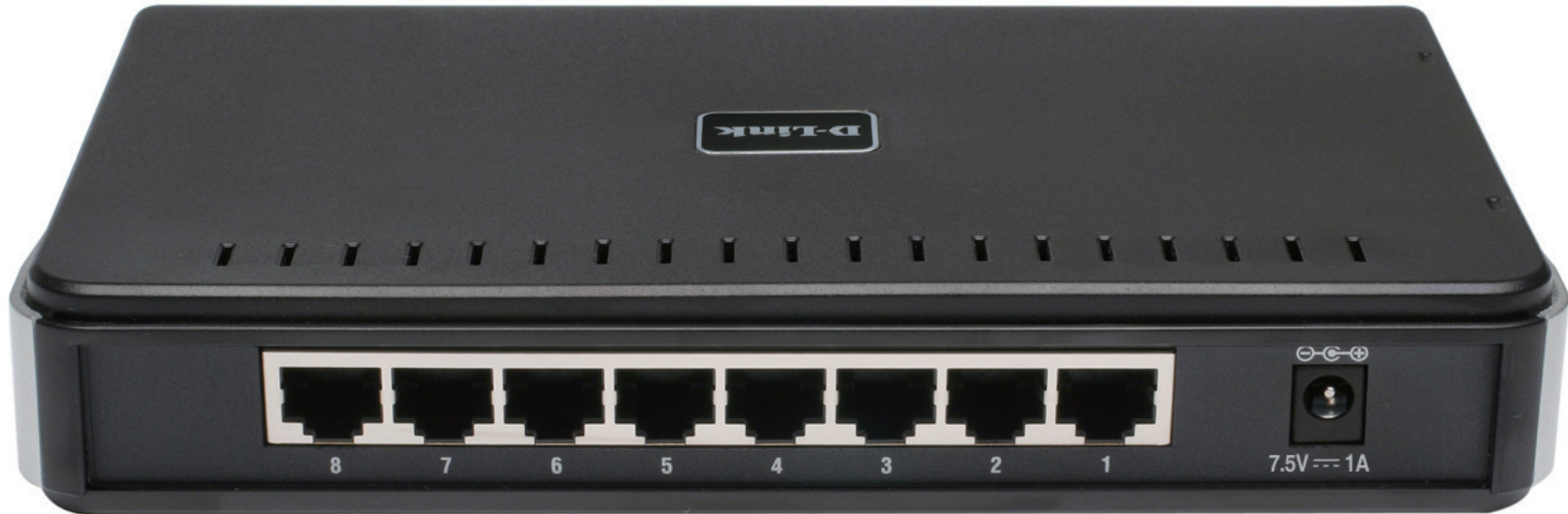

### **Auto MDI/MDI-X Ports:**

Eight (8) Gigabit Ethernet, Auto-Negotiating ports (10/100/1000Mbps) Comprehensive LED indicators display the conditions of the Switch and status of the network.

### **DC Power Jack:**

Power is supplied through an external AC power adapter. Check the technical specification section for information about the AC power input voltage.

Since the DGS-2208 does not require a power button, plugging its power adapter into a power outlet will immediately power it on.



# Installation

This section will explain how to connect Ethernet devices to your new D-Link switch and how to mount the switch.

## Before You Connect to the Network

The site where you install the Switch may greatly affect its performance. Please follow these guidelines for setting up the Switch.

- Install the Switch on a sturdy, level surface that can support at least 3 kg (6.6 lbs.) of weight. Do not place heavy objects on the Switch.
- The power outlet should be within 1.82 meters (6 feet) of the Switch.
- Visually inspect the power cord and see that it is fully secured to the AC power port.
- Make sure that there is adequate space for proper heat dissipation from and adequate ventilation around the Switch. Leave at least 10 cm (4 inches) of space at the front and rear of the Switch for ventilation.
- Install the Switch in a fairly cool and dry place for the acceptable temperature and humidity operating ranges.
- Install the Switch in a site free from strong electromagnetic field generators (such as motors), vibration, dust, and direct exposure to sunlight.
- When installing the Switch on a level surface, attach the rubber feet to the bottom of the device. The rubber feet cushion the Switch, protect the casing from scratches, and prevent it from scratching other surfaces.



# Mounting the Switch on the Wall

The DGS-2208 can also be mounted on a wall. Two mounting slots are provided on the bottom of the switch for this purpose. Please make sure that the front panel is exposed in order to view the LEDs. Please refer to the illustration below:

## Mounting on a cement wall

1. Mount the Nylon screw anchors into a cement wall.
2. Drive the T3 x 15L screws into the Nylon screw anchors.
3. Hook the mounting holes of the switch back on the screws.

## Mounting on a wood wall

1. Drive the T3 x 15 L screws into the wood wall.
2. Hook the mounting holes of the switch back on the screws.

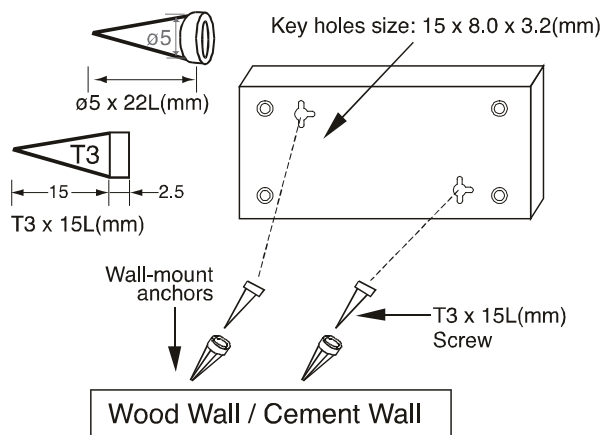

(1) 3/4 inch minimum for wood wall

(2) 3 inch minimum for cement wall.

# Connecting the Switch

## DGS-2208 to End Node

End nodes include PCs outfitted with a 10, 100, or 1000 Mbps RJ-45 Ethernet Network Interface Card (NIC) and most routers. An end node can be connected to the Switch via a twisted-pair Category 3, 4, 5, or 5e UTP/STP cable. The end node can be connected to any of the ports of the Switch.

The Link/Act LEDs for each UTP port light green when the link is valid. The LED over the port label indicates a port speed of either 10/100 Mbps or 1000Mbps. A blinking LED on the bottom indicates packet activity on that port.

## Hub/Switch to DGS-2208

These connections can be accomplished in a number of ways using a standard Ethernet cable.

- A 10BASE-T hub or switch can be connected to the Switch via a twisted-pair Category 3, 4, 5, or 5e UTP/STP cable.
- A 100BASE-TX hub or switch can be connected to the Switch via a twisted -pair Category 5 UTP/STP cable.
- A 1000BASE-T switch can be connected to the Switch via a twisted -pair Category 5e or better UTP/STP cable.

## Connecting To Network Backbone or Server

Any of the eight Gigabit Ethernet ports are ideal for uplinking to a network backbone or network server.

# Troubleshooting

## **1. Why can't I share my Internet connection to multiple computers when using my D-Link DGS-2208 switch?**

If you are connecting directly to a Cable or DSL modem, you will need a router to “share” your Internet connection or a computer using ICS (Internet Connection Sharing) or Proxy. Switches and hubs do not allow you to share a single IP address to multiple computers.

Another alternative is to contact your ISP and purchase extra IP addresses for each additional computer.

## **2. Does the DGS-2208 switch have an uplink port?**

The DGS-2208 has Auto-MDI ports which automatically sense the type of cable being used (e.g. Straight-through or Crossover) and adjust themselves accordingly to pass data over the network.

## **3. What is the maximum length of Category 3, 4 or 5 twisted pair cable that can be used between the DGS-2208 and other devices such as routers, switches, computers, etc.?**

The maximum length of Category 3, 4 or 5 twisted pair cable that can be used between computers and other devices on a network is 100 meters or about 328 feet. Keep in mind that this is a theoretical limit. Usually, you will want to keep the distance between devices well below the limit.

# Glossary

## **1000BASE-T**

A specification for Gigabit Ethernet over copper (IEEE 802.3ab). The standard defines 1 Gbps data transfer over distances of up to 100 meters using 4 pairs of CAT-5 balanced copper cabling and a 5-level coding scheme. Its benefits include compatibility with existing network protocols (i.e. IP, IPX, AppleTalk), existing applications, Network Operating Systems, network management platforms and applications.

## **100BASE-TX**

100Mbps Ethernet implementation over Category 5 and Type 1 Twisted Pair cabling.

## **10BASE-T**

The IEEE 802.3 specification for Ethernet over Unshielded Twisted Pair (UTP) cabling.

## **aging**

The automatic removal of dynamic entries from the Switch Database which have timed-out and are no longer valid.

## **auto-negotiation**

A feature on a port, which allows it to advertise its capabilities for speed, duplex, and flow control. When connected to an end station that also supports auto-negotiation, the link can self-detect its optimum operating setup.

## **backbone port**

A port that does not learn device addresses, and that receives all frames with an unknown address. Backbone ports are normally used to connect the Switch to the backbone of your network. Note that backbone ports were formerly known as designated downlink ports.

## **backbone**

The part of a network used as the primary path for transporting traffic between network segments.

**Bandwidth**

Information capacity, measured in bits per second, that a channel can transmit. The bandwidth of Ethernet is 10Mbps, the bandwidth of Fast Ethernet is 100Mbps.

**BOOTP**

The BOOTP protocol allows you to automatically map an IP address to a given MAC address each time a device is started. In addition, the protocol can assign the subnet mask and default gateway to a device.

**bridge**

A device that interconnects local or remote networks no matter what higher level protocols are involved. Bridges form a single logical network, centralizing network administration.

**broadcast**

A message sent to all destination devices on the network.

**broadcast storm**

Multiple simultaneous broadcasts that typically absorb available network bandwidth and can cause network failure.

**console port**

The port on the Switch accepting a terminal or modem connector. It changes the parallel arrangement of data within computers to the serial form used on data transmission links. This port is most often used for dedicated local management.

**data center switching**

The point of aggregation within a corporate network where a switch provides high performance access to server farms, a high-speed backbone connection, and a control point for network management and security.

**Ethernet**

A LAN specification developed jointly by Xerox, Intel, and Digital Equipment Corporation. Ethernet networks operate at 10Mbps using CSMA/CD to run over cabling.

**Fast Ethernet**

100Mbps technology based on the Ethernet/CD network access method.

**Flow Control – (IEEE 802.3x)**

A means of holding packets back at the transmit port of the connected end station. Prevents packet loss at a congested switch port.

**forwarding**

The process of sending a packet toward its destination by an internetworking device.

**full duplex**

A system that allows packets to be transmitted and received at the same time and, in effect, doubles the potential throughput of a link.

**half duplex**

A system that allows packets to be transmitted and received, but not at the same time. Contrast with full duplex.

**IP address**

Internet Protocol address. A unique identifier for a device attached to a network using TCP/IP. The address is written as four octets separated with full-stops (periods), and is made up of a network section, an optional subnet section and a host section.

**LAN**

Local Area Network. A network of connected computing resources (such as PCs, printers, servers) covering a relatively small geographic area (usually not larger than a floor or building). Characterized by high data rates and low error rates.

**latency**

The delay between the time a device receives a packet and the time the packet is forwarded out of the destination port.

**main port**

The port in a resilient link that carries data traffic in normal operating conditions.

**MDI**

Medium Dependent Interface. An Ethernet port connection where the transmitter of one device is connected to the receiver of another device.

**MDI-X**

Medium Dependent Interface Cross-over. An Ethernet port connection where the internal transmit and receive lines are crossed.

**protocol**

A set of rules for communication between devices on a network. The rules dictate format, timing, sequencing, and error control.

**resilient link**

A pair of ports that can be configured so that one will take over data transmission should the other fail. See also main port and standby port.

**RJ-45**

Standard 8-wire connectors for IEEE 802.3 10BASE-T networks.

**RPS**

Redundant Power System. A device that provides a backup source of power when connected to the Switch.

**server farm**

A cluster of servers in a centralized location serving a large user population.

**SLIP**

Serial Line Internet Protocol. A protocol that allows IP to run over a serial line connection.



## **SNMP**

Simple Network Management Protocol. A protocol originally designed to be used in managing TCP/IP internets. SNMP is presently implemented on a wide range of computers and networking equipment and may be used to manage many aspects of network and end station operation.

## **standby port**

The port in a resilient link that will take over data transmission if the main port in the link fails.

## **switch**

A device that filters, forwards, and floods packets based on the packet's destination address. The Switch learns the addresses associated with each switch port and builds tables based on this information to be used for the switching decision.

## **TCP/IP**

A layered set of communications protocols providing Telnet terminal emulation, FTP file transfer, and other services for communication among a wide range of computer equipment.

## **UDP**

User Datagram Protocol. An Internet standard protocol that allows an application program on one device to send a datagram to an application program on another device.

## **VLAN**

Virtual LAN. A group of location- and topology-independent devices that communicate as if they are on a common physical LAN.

# Networking Basics

## Check your IP address

After you install your new D-Link adapter or if you already have an Ethernet adapter installed on your computer, by default, the TCP/IP settings should be set to obtain an IP address from a DHCP server (i.e. router) automatically. To verify your IP address, please follow the steps below.

### Windows® XP/2000 Users

- Click on **Start > Run**. In the run box type **cmd** and click **OK**.
- At the prompt, type **ipconfig** and press **Enter**.
- This will display the IP address, subnet mask, and the default gateway of your adapter.

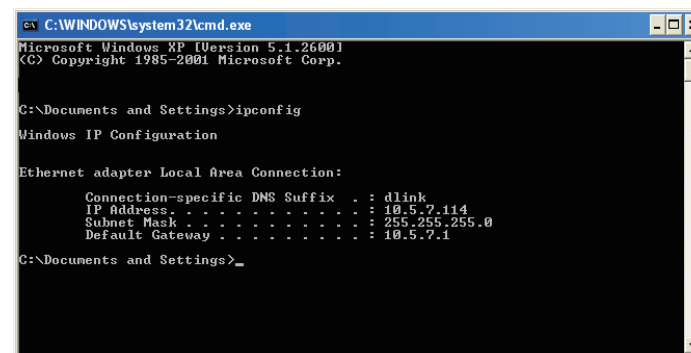

```

C:\WINDOWS\system32\cmd.exe
Microsoft Windows XP [Version 5.1.2600]
(C) Copyright 1985-2001 Microsoft Corp.

C:\Documents and Settings>ipconfig

Windows IP Configuration

Ethernet adapter Local Area Connection:

    Connection-specific DNS Suffix  . : dlink
    IP Address. . . . .               : 10.5.7.114
    Subnet Mask . . . . .             : 255.255.255.0
    Default Gateway . . . . .         : 10.5.7.1

C:\Documents and Settings>
  
```

### Windows Vista™ Users

- Click **Start > All Programs > Accessories > Command Prompt**. You may need administrative access to run this application.
- For all additional prompt windows inquiring of running the command prompt application, select **Yes, OK, or Continue**.
- At the prompt, type **ipconfig** and press **Enter**.
- This will display the IP address, subnet mask, and default gateway of your adapter.

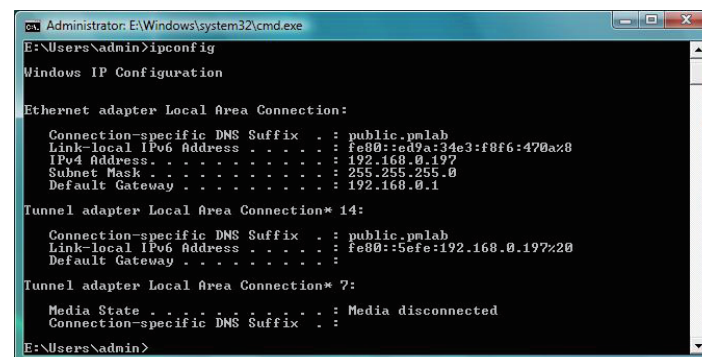

```

Administrator: E:\Windows\system32\cmd.exe
E:\Users\admin>ipconfig

Windows IP Configuration

Ethernet adapter Local Area Connection:

    Connection-specific DNS Suffix  . : public.pmlab
    Link-local IPv6 Address . . . . . : fe80::ed9a:34e3:f8f6:470a%8
    IPv4 Address. . . . .             : 192.168.0.197
    Subnet Mask . . . . .             : 255.255.255.0
    Default Gateway . . . . .         : 192.168.0.1

Tunnel adapter Local Area Connection* 14:

    Connection-specific DNS Suffix  . : public.pmlab
    Link-local IPv6 Address . . . . . : fe80::5efe:192.168.0.197%20
    Default Gateway . . . . .         : 192.168.0.1

Tunnel adapter Local Area Connection* 7:

    Media State . . . . .              : Media disconnected
    Connection-specific DNS Suffix  . :

E:\Users\admin>
  
```

If the address is 0.0.0.0, check your adapter installation, security settings, and the settings on your router. Some firewall software programs may block a DHCP request on newly installed adapters.

# Statically Assign an IP address

If you are not using a DHCP capable gateway/router, or you need to assign a static IP address, please follow the steps below:

## Windows® XP/2000 Users

- **Windows® XP** - Click on **Start > Control Panel**. Make sure you are in Classic View. Double-click on the Network Connections icon.  
**Windows® 2000** – From the desktop, right-click **My Network Places > Properties**.
- Right-click on the **Local Area Connection** which represents your D-Link network adapter (or other adapter) which will be connected to your router.
- Highlight **Internet Protocol (TCP/IP)** and click **Properties**.
- Click **Use the following IP address** and enter an IP address that is on the same subnet as your network or LAN IP address on your router.

**Example:** If the router's LAN IP address is 192.168.0.1, make your IP address 192.168.0.X where X is a number between 2 and 99. Make sure that the number you choose is not in use on the network.

- Set **Default Gateway** the same as the LAN IP address of your router or gateway.
- Set **Primary DNS** the same as the LAN IP address of your router or gateway.
- The **Secondary DNS** is optional (you may enter a DNS server from your ISP).
- Click **OK** to save your settings.

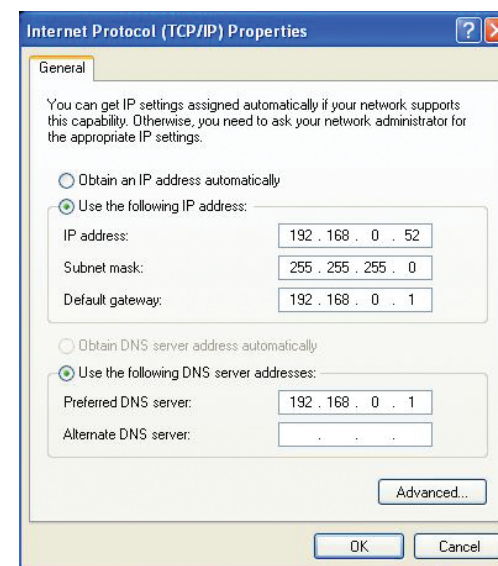

## Windows Vista™ Users

- Click on **Start > Control Panel**. Make sure you are in Classic View. Double-click on the **Network and Sharing Center** icon. Along the left panel in the window, click on **Manage network connections**.
- Right-click on the **Local Area Connection** which represents your D-Link network adapter (or other adapter) which will be connected to your network.
- Highlight **Internet Protocol Version 4 (TCP /IPv4)** and click **Properties**.
- Click **Use the following IP address** and enter an IP address that is on the same subnet as your network or LAN IP address on your router or network.

**Example:** If the router's LAN IP address is 192.168.0.1, make your IP address 192.168.0.X where X is a number between 2 and 99. Make sure that the number you choose is not in use on the network.

- Set **Default Gateway** the same as the LAN IP address of your router or gateway.
- Set **Primary DNS** the same as the LAN IP address of your router or gateway.
- The **Secondary DNS** is optional (you may enter a DNS server from your ISP).
- Click **OK** to save your settings.

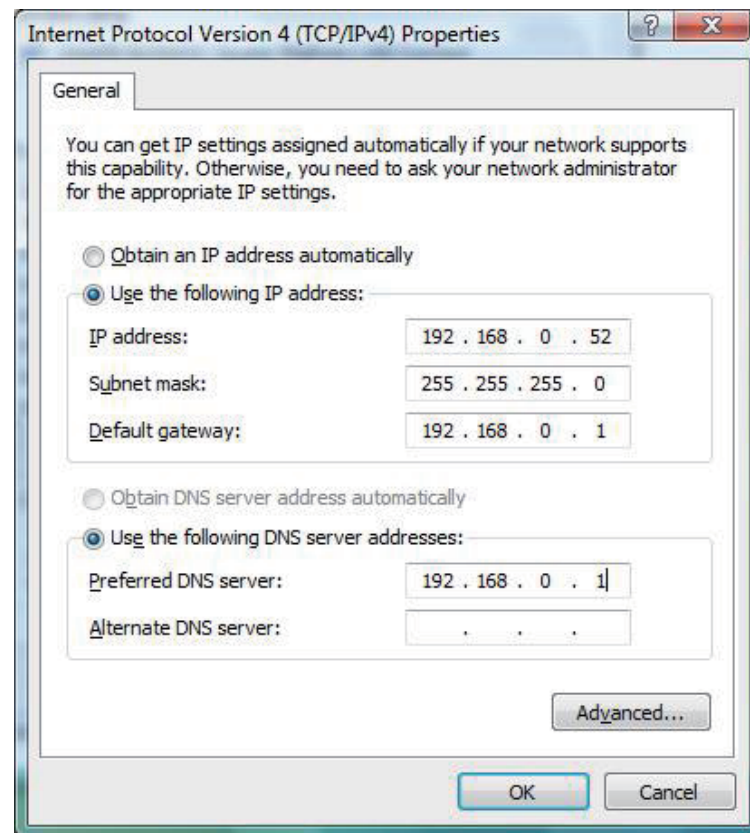

# Technical Specifications

## DGS-2208 Specifications

### Technical Specifications

<b>Ports:</b>	Eight (8) Ports 10/100/1000Mbps
<b>MAC Address Table Size:</b>	4K
<b>Switch Fabric:</b>	16Gbps Forwarding Capacity
<b>Transmission Method</b>	Store-and-forward
<b>Diagnostic LEDs</b>	Per Unit: Power Per Port: Activity/Link, 100/1000M
<b>Packet Buffer Memory</b>	192 KBytes
<b>Forwarding Rate</b>	10Mbps-14,880pps/100Mbps-148,810pps/ 1000Mbps-1,488,100pps
<b>Address Aging Timer</b>	Automatic Update
<b>Max Power Consumption</b>	5.2 Watts
<b>QoS</b>	802.1p (4 Queues)
<b>Jumbo Frames</b>	9720 Bytes

### Interface Options

<b>RJ-45</b>	10BASE-T, 100BASE-TX & 1000BASE-T Universal UTP Cable Recognition for Straight-Through or Crossover Cables (MDI/MDI-X)
--------------	--

## Network Protocols and Standards

IEEE 802.3 Ethernet, 802.3u Fast Ethernet, 802.3ab Gigabit Ethernet,  
802.3x Flow Control, 802.1p QoS

## Electrical & Emissions Summary

**Emissions** CE Mark, FCC Class B, VCCI Class B

**External Power Adapter** DC 7.5V/1A  
DC 5V/2A

## Safety Agency Certifications and Environmental

**Safety** cUL

**Temperature** Operating: 0° - 40° C (32° - 131° F)  
Storage: -10° - 70° C (14° - 158° F)

**Humidity** Operating: 10% to 90% RH, Non Condensing

## Physical Specifications

**Dimensions** (W x D x H) 7.8 x 4.7 x 1.24 inches (198mm x 120.5mm x 31.5mm)

# Contacting Technical Support

D-Link provides free technical support for customers within the United States and within Canada for the duration of the warranty period on this product. U.S. and Canadian customers can contact D-Link technical support through our web site or by phone.

Before you contact technical support, please have the following ready:

- Model number of the product (e.g. DGS-2208)
- Hardware Revision (located on the label on the bottom of the switch (e.g. rev A1))
- Serial Number (s/n number located on the label on the bottom of the switch).

You can find software updates and user documentation on the D-Link website as well as frequently asked questions and answers to technical issues.

## For customers within the United States:

**Phone Support:**  
(877) 453-5465

**Internet Support:**  
<http://support.dlink.com>

## For customers within Canada:

**Phone Support:**  
(800) 361-5265

**Internet Support:**  
<http://support.dlink.com>



# Warranty

Subject to the terms and conditions set forth herein, D-Link Systems, Inc. (“D-Link”) provides this Limited Warranty:

- Only to the person or entity that originally purchased the product from D-Link or its authorized reseller or distributor, and
- Only for products purchased and delivered within the fifty states of the United States, the District of Columbia, U.S. Possessions or Protectorates, U.S. Military Installations, or addresses with an APO or FPO.

## **Limited Warranty:**

D-Link warrants that the hardware portion of the D-Link product described below (“Hardware”) will be free from material defects in workmanship and materials under normal use from the date of original retail purchase of the product, for the period set forth below (“Warranty Period”), except as otherwise stated herein.

- Hardware (excluding power supplies and fans): Three (3) year
- Power supplies and fans: One (1) year
- Spare parts and spare kits: Ninety (90) days

The customer’s sole and exclusive remedy and the entire liability of D-Link and its suppliers under this Limited Warranty will be, at D-Link’s option, to repair or replace the defective Hardware during the Warranty Period at no charge to the original owner or to refund the actual purchase price paid. Any repair or replacement will be rendered by D-Link at an Authorized D-Link Service Office. The replacement hardware need not be new or have an identical make, model or part. D-Link may, at its option, replace the defective Hardware or any part thereof with any reconditioned product that D-Link reasonably determines is substantially equivalent (or superior) in all material respects to the defective Hardware. Repaired or replacement hardware will be warranted for the remainder of the original Warranty Period or ninety (90) days, whichever is longer, and is subject to the same limitations and exclusions. If a material defect is incapable of correction, or if D-Link determines that it is not practical to repair or replace the defective Hardware, the actual price paid by the original purchaser for the defective Hardware will be refunded by D-Link upon return to D-Link of the defective Hardware. All Hardware or part thereof that is replaced by D-Link, or for which the purchase price is refunded, shall become the property of D-Link upon replacement or refund.

### **Limited Software Warranty:**

D-Link warrants that the software portion of the product (“Software”) will substantially conform to D-Link’s then current functional specifications for the Software, as set forth in the applicable documentation, from the date of original retail purchase of the Software for a period of ninety (90) days (“Software Warranty Period”), provided that the Software is properly installed on approved hardware and operated as contemplated in its documentation. D-Link further warrants that, during the Software Warranty Period, the magnetic media on which D-Link delivers the Software will be free of physical defects. The customer’s sole and exclusive remedy and the entire liability of D-Link and its suppliers under this Limited Warranty will be, at D-Link’s option, to replace the non-conforming Software (or defective media) with software that substantially conforms to D-Link’s functional specifications for the Software or to refund the portion of the actual purchase price paid that is attributable to the Software. Except as otherwise agreed by DLink in writing, the replacement Software is provided only to the original licensee, and is subject to the terms and conditions of the license granted by D-Link for the Software. Replacement Software will be warranted for the remainder of the original Warranty Period and is subject to the same limitations and exclusions. If a material non-conformance is incapable of correction, or if D-Link determines in its sole discretion that it is not practical to replace the non-conforming Software, the price paid by the original licensee for the non-conforming Software will be refunded by D-Link; provided that the non-conforming Software (and all copies thereof) is first returned to D-Link. The license granted respecting any Software for which a refund is given automatically terminates.

### **Non-Applicability of Warranty:**

The Limited Warranty provided hereunder for Hardware and Software portions of D-Link’s products will not be applied to and does not cover any refurbished product and any product purchased through the inventory clearance or liquidation sale or other sales in which D-Link, the sellers, or the liquidators expressly disclaim their warranty obligation pertaining to the product and in that case, the product is being sold “As-Is” without any warranty whatsoever including, without limitation, the Limited Warranty as described herein, notwithstanding anything stated herein to the contrary.

### **Submitting A Claim:**

The customer shall return the product to the original purchase point based on its return policy. In case the return policy period has expired and the product is within warranty, the customer shall submit a claim to D-Link as outlined below:

- The customer must submit with the product as part of the claim a written description of the Hardware defect or Software nonconformance in sufficient detail to allow DLink to confirm the same, along with proof of purchase of the product (such as a copy of the dated purchase invoice for the product) if the product is not registered.
- The customer must obtain a Case ID Number from D-Link Technical Support at 1-877-453-5465, who will attempt to assist the customer in resolving any suspected defects with the product. If the product is considered defective, the customer must obtain a Return Material Authorization (“RMA”) number by completing the RMA form and entering the assigned Case ID Number at <https://rma.dlink.com/>.

- After an RMA number is issued, the defective product must be packaged securely in the original or other suitable shipping package to ensure that it will not be damaged in transit, and the RMA number must be prominently marked on the outside of the package. Do not include any manuals or accessories in the shipping package. DLink will only replace the defective portion of the product and will not ship back any accessories.
- The customer is responsible for all in-bound shipping charges to D-Link. No Cash on Delivery (“COD”) is allowed. Products sent COD will either be rejected by D-Link or become the property of D-Link. Products shall be fully insured by the customer and shipped to D-Link Systems, Inc., 17595 Mt. Herrmann, Fountain Valley, CA 92708. D-Link will not be held responsible for any packages that are lost in transit to D-Link. The repaired or replaced packages will be shipped to the customer via UPS Ground or any common carrier selected by D-Link. Return shipping charges shall be prepaid by D-Link if you use an address in the United States, otherwise we will ship the product to you freight collect. Expedited shipping is available upon request and provided shipping charges are prepaid by the customer. D-Link may reject or return any product that is not packaged and shipped in strict compliance with the foregoing requirements, or for which an RMA number is not visible from the outside of the package. The product owner agrees to pay D-Link’s reasonable handling and return shipping charges for any product that is not packaged and shipped in accordance with the foregoing requirements, or that is determined by D-Link not to be defective or non-conforming.

### **What Is Not Covered:**

The Limited Warranty provided herein by D-Link does not cover:

Products that, in D-Link’s judgment, have been subjected to abuse, accident, alteration, modification, tampering, negligence, misuse, faulty installation, lack of reasonable care, repair or service in any way that is not contemplated in the documentation for the product, or if the model or serial number has been altered, tampered with, defaced or removed; Initial installation, installation and removal of the product for repair, and shipping costs; Operational adjustments covered in the operating manual for the product, and normal maintenance; Damage that occurs in shipment, due to act of God, failures due to power surge, and cosmetic damage; Any hardware, software, firmware or other products or services provided by anyone other than D-Link; and Products that have been purchased from inventory clearance or liquidation sales or other sales in which D-Link, the sellers, or the liquidators expressly disclaim their warranty obligation pertaining to the product.

While necessary maintenance or repairs on your Product can be performed by any company, we recommend that you use only an Authorized D-Link Service Office. Improper or incorrectly performed maintenance or repair voids this Limited Warranty.

### **Disclaimer of Other Warranties:**

EXCEPT FOR THE LIMITED WARRANTY SPECIFIED HEREIN, THE PRODUCT IS PROVIDED “AS-IS” WITHOUT ANY WARRANTY OF ANY KIND WHATSOEVER INCLUDING, WITHOUT LIMITATION, ANY WARRANTY OF MERCHANTABILITY, FITNESS FOR A PARTICULAR PURPOSE AND NONINFRINGEMENT.

IF ANY IMPLIED WARRANTY CANNOT BE DISCLAIMED IN ANY TERRITORY WHERE A PRODUCT IS SOLD, THE DURATION OF SUCH IMPLIED WARRANTY SHALL BE LIMITED TO THE DURATION OF THE APPLICABLE WARRANTY PERIOD SET FORTH ABOVE. EXCEPT AS EXPRESSLY COVERED UNDER THE LIMITED WARRANTY PROVIDED HEREIN, THE ENTIRE RISK AS TO THE QUALITY, SELECTION AND PERFORMANCE OF THE PRODUCT IS WITH THE PURCHASER OF THE PRODUCT.

**Limitation of Liability:**

TO THE MAXIMUM EXTENT PERMITTED BY LAW, D-LINK IS NOT LIABLE UNDER ANY CONTRACT, NEGLIGENCE, STRICT LIABILITY OR OTHER LEGAL OR EQUITABLE THEORY FOR ANY LOSS OF USE OF THE PRODUCT, INCONVENIENCE OR DAMAGES OF ANY CHARACTER, WHETHER DIRECT, SPECIAL, INCIDENTAL OR CONSEQUENTIAL (INCLUDING, BUT NOT LIMITED TO, DAMAGES FOR LOSS OF GOODWILL, LOSS OF REVENUE OR PROFIT, WORK STOPPAGE, COMPUTER FAILURE OR MALFUNCTION, FAILURE OF OTHER EQUIPMENT OR COMPUTER PROGRAMS TO WHICH D-LINK'S PRODUCT IS CONNECTED WITH, LOSS OF INFORMATION OR DATA CONTAINED IN, STORED ON, OR INTEGRATED WITH ANY PRODUCT RETURNED TO D-LINK FOR WARRANTY SERVICE) RESULTING FROM THE USE OF THE PRODUCT, RELATING TO WARRANTY SERVICE, OR ARISING OUT OF ANY BREACH OF THIS LIMITED WARRANTY, EVEN IF D-LINK HAS BEEN ADVISED OF THE POSSIBILITY OF SUCH DAMAGES. THE SOLE REMEDY FOR A BREACH OF THE FOREGOING LIMITED WARRANTY IS REPAIR, REPLACEMENT OR REFUND OF THE DEFECTIVE OR NONCONFORMING PRODUCT. THE MAXIMUM LIABILITY OF D-LINK UNDER THIS WARRANTY IS LIMITED TO THE PURCHASE PRICE OF THE PRODUCT COVERED BY THE WARRANTY. THE FOREGOING EXPRESS WRITTEN WARRANTIES AND REMEDIES ARE EXCLUSIVE AND ARE IN LIEU OF ANY OTHER WARRANTIES OR REMEDIES, EXPRESS, IMPLIED OR STATUTORY.

**Governing Law:**

This Limited Warranty shall be governed by the laws of the State of California. Some states do not allow exclusion or limitation of incidental or consequential damages, or limitations on how long an implied warranty lasts, so the foregoing limitations and exclusions may not apply. This Limited Warranty provides specific legal rights and you may also have other rights which vary from state to state.

**Trademarks:**

D-Link is a registered trademark of D-Link Systems, Inc. Other trademarks or registered trademarks are the property of their respective owners.

**Copyright Statement:**

No part of this publication or documentation accompanying this product may be reproduced in any form or by any means or used to make any derivative such as translation, transformation, or adaptation without permission from D-Link Corporation/D-Link Systems, Inc., as stipulated by the United States Copyright Act of 1976 and any amendments thereto. Contents are subject to change without prior notice.

Copyright ©2008 by D-Link Corporation/D-Link Systems, Inc. All rights reserved.

**CE Mark Warning:**

This is a Class B product. In a domestic environment, this product may cause radio interference, in which case the user may be required to take adequate measures.

**FCC Statement:**

This equipment has been tested and found to comply with the limits for a Class B digital device, pursuant to part 15 of the FCC Rules. These limits are designed to provide reasonable protection against harmful interference in a residential installation. This equipment generates, uses, and can radiate radio frequency energy and, if not installed and used in accordance with the instructions, may cause harmful interference to radio communication. However, there is no guarantee that interference will not occur in a particular installation. If this equipment does cause harmful interference to radio or television reception, which can be determined by turning the equipment off and on, the user is encouraged to try to correct the interference by one or more of the following measures:

- Reorient or relocate the receiving antenna.
- Increase the separation between the equipment and receiver.
- Connect the equipment into an outlet on a circuit different from that to which the receiver is connected.
- Consult the dealer or an experienced radio/TV technician for help.

For detailed warranty information applicable to products purchased outside the United States, please contact the corresponding local D-Link office.

# Registration



Product registration is entirely voluntary and failure to complete or return this form will not diminish your warranty rights.

Version 3.1  
March 03, 2009