

ITEM NO.	DESCRIPTION	MODEL 111	MODEL 1001	QTY. PER UNIT
MOUNT ASSEMBLY		.249C019S242	.249C019S242	.1
*1	.STOPPER	.174C068P01	.174C068P01	.1
*2	.SPLASH GUARD	.614C069P01	.614C069P01	.1
*3	.SINKFLANGE & CAP ASSEMBLY.	.249C014S35	.249C014S35	.1
*4	.RUBBER GASKET	.269C031P01	.269C031P01	.1
*5	.FIBER GASKET (WAXED)	.269C033P01	.269C033P01	.1
*6	.SUPPORT RING	.614C072P01	.614C072P01	.1
*7	.MOUNT RING	.614C059P02	.614C059P02	.1
*8	.CUSHION MOUNT RING	.469C004P02	.469C004P02	.1
9	.OUTLET SCREW	.636C017P03	.636C017P03	.2
10	.OUTLET FLANGE	.249C009P01	.249C009P01	.1
11	.OUTLET ELBOW	.673C015P01	.673C015P01	.1
12	.RUBBER OUTLET GASKET	.269C038P01	.269C038P01	.1
DRAIN HOUSING ASSEMBLY		.311C080S03	.311C080S03	.1
*13	.GRIND RING	.614C066P03	.614C066P03	.2
*14	.DRAIN HOUSING	.311C080P01	.311C080P01	.1
*15	.THRUST WASHER	.789C041P01	.789C041P01	.1
*16	.WATER SEAL	.645C006P01	.645C006P01	.1
*17	.SPACER SEAL	.102C005P01	.102C005P01	.1
18	.SLINGER	.789C034P04	.789C034P04	.1
19	.O-RING	.645C004P01	.645C004P01	.1
20	.TURNTABLE ASSEMBLY	.258C032S01	.258C032S01	.1
21	.HOPPER ASSEMBLY	.311C077S01	.311C077S01	.1
22	.HOPPER SCREW	.636C023P01	.636C023P01	.4
23	.WASHER	.789C035P02	.789C035P02	.1
24	.ARMATURE ASSEMBLY.	.626C035P02	.626C035P03	.1
25	.MOTOR STUD	.687C003P01	.687C003P01	.1
26	.MOTOR STUD	.687C003P02	.687C003P02	.1
27	.MOTOR SHELL ASSEMBLY.	.681C031S12	.681C031S12	.1
ENDBELL ASSEMBLY		.311C081S01	.311C081S02	.1
*28	.ENDBELL.	.311C081S53	.311C081S53	.1
*29	.MOTOR BRUSH & BRUSH SPRING ASSY	.027C029S02	.027C029S02	.2
30	.NUT	.479C019P01	.479C019P01	.2
31	.INSPECTION PLATE	.554C032P01	.554C032P01	.1
32	.NUT	.479C021P01	.479C021P01	.1
33	.SHELL SCREW	.636C029P02	.636C029P02	.3
34	.LOWER SHELL	.806C044P03	.806C044P03	.1

\*PART OF AN ASSEMBLY, BUT CAN BE PURCHASED SEPARATELY.



**Waste King**  
*Legend Series*  
by Anaheim Manufacturing Company

**PARTS LIST**  
**MODELS 111 & 1001**

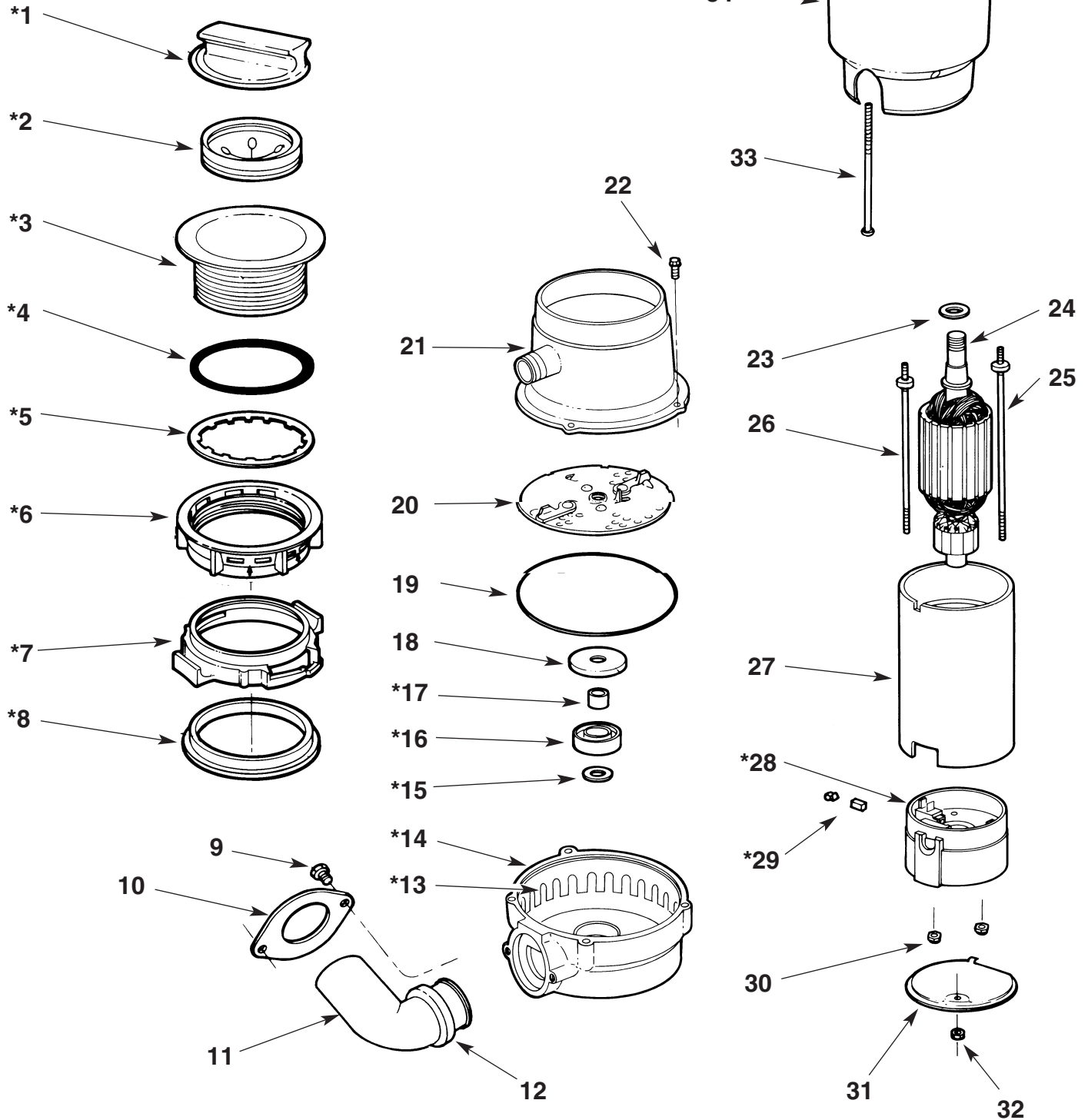

P.O. BOX 4146  
ANAHEIM, CA 92803 U.S.A.

\* PART OF AN ASSEMBLY, BUT CAN BE PURCHASED SEPARATELY.

ITEM NO.	DESCRIPTION	MODEL L-2600	QTY. PER UNIT
MOUNT ASSEMBLY		.249C019S242	.1
*1	STOPPER	.174C067P01	.1
*2	SPLASH GUARD	.614C069P01	.1
*3	SINKFLANGE & CAP ASSEMBLY	.249C014S35	.1
*4	RUBBER GASKET	.269C031P01	.1
*5	FIBER GASKET (WAXED)	.269C033P01	.1
*6	SUPPORT RING	.614C072P01	.1
*7	MOUNT RING	.614C059P02	.1
*8	CUSHION MOUNT RING	.469C004P02	.1
9	OUTLET SCREW	.636C017P03	.2
10	OUTLET FLANGE	.249C009P01	.1
11	OUTLET ELBOW	.673C015P01	.1
12	RUBBER OUTLET GASKET	.269C038P01	.1
13	GRIND RING	.614C066P02	.2
DRAIN HOUSING ASSEMBLY		.311C080S02	.1
*14	DRAIN HOUSING	.311C080P02	.1
*15	THRUST WASHER	.789C041P01	.1
*16	WATER SEAL	.645C006P01	.1
*17	SPACER SEAL	.102C005P01	.1
TURNTABLE ASSEMBLY		.258C032S02	.1
*18	SLINGER	.789C034P03	.1
*19	O-RING	.645C004P01	.1
*20	TURNTABLE	.258C032P02	.1
21	HOPPER ASSEMBLY	.311C076P01	.1
22	HOPPER SCREW	.636C023P01	.4
23	WASHER	.789C035P02	.1
24	ARMATURE ASSEMBLY	.626C035P03	.1
25	STUD MOTOR	.687C003P01	.1
26	STUD MOTOR	.687C003P02	.1
27	MOTOR SHELL ASSEMBLY.	.681C031S12	.1
ENDBELL ASSEMBLY		.311C081S02	.1
*28	ENDBELL	.311C081P01	.1
*29	MOTOR BRUSH & BRUSH SPRING ASSEMBLY	.027C029S02	.1
30	NUT	.479C019P01	.2
31	INSPECTION PLATE	.554C032P01	.1
32	NUT	.479C021P01	.1
33	UPPER SHELL	.806C067P01	.1
34	LOWER SHELL	.806C068P01	.1
35	SHELL SCREW	.636C024P01	.3
†36	SINKFLANGE GASKET-WAXED (THICK)	.269C032P01	.1

†NOT SHOWN

\*PART OF AN ASSEMBLY, BUT CAN BE PURCHASED SEPARATELY.



# Waste King

## Legend Series

by Anaheim Manufacturing Company

### PARTS LIST MODEL 2600

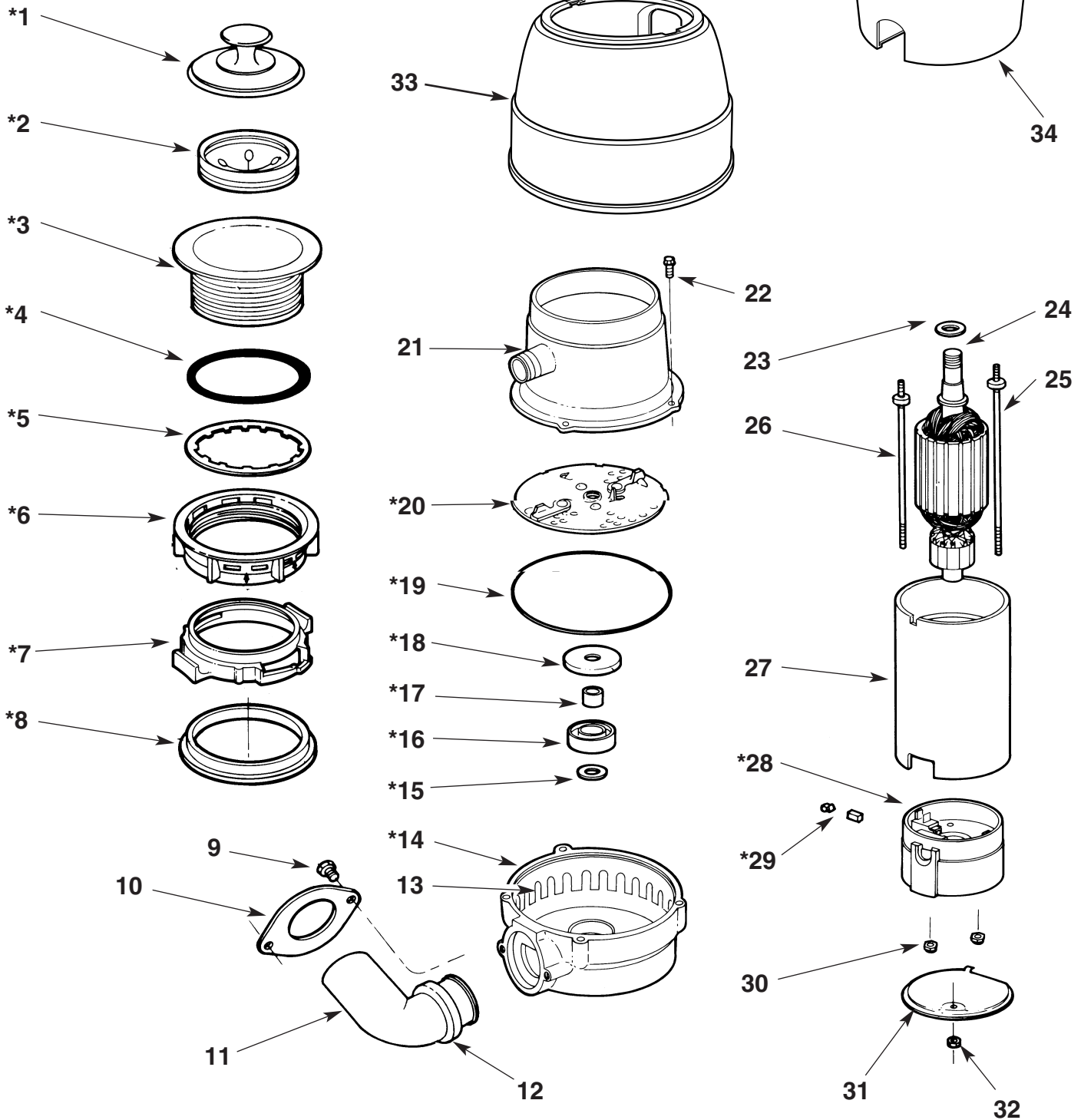

P.O. BOX 4146  
ANAHEIM, CA 92803 U.S.A.

\* PART OF AN ASSEMBLY, BUT CAN BE PURCHASED SEPARATELY.

## MODEL L-2600TC

ITEM #	DESCRIPTION	PART #	QTY	ITEM #	DESCRIPTION	PART #	QTY
	MOUNT ASSEMBLY	.249C019S242BF	..1	33	..NUT	.479C021P01	....1
*1	..STOPPER	.174C066S02	....1	34	..UPPER SHELL	.806C067P51	....1
*2	..SINKFLANGE & CAP ASSY.	.249C014S35	....1	35	..LOWER SHELL	.806C068P01	....1
*3	..RUBBER GASKET	.269C031P01	....1	36	..SHELL SCREW	.636C014P19	....3
*4	..FIBER GASKET (WAXED)	.269C033P01	....1	37	..PLUNGER BUTTON	.106C004P01	....1
*5	..SUPPORT RING	.614C072P01	....1	38	..”O” RING	.614C027P01	....2
*6	..MOUNT RING	.614C059P02	....1	39	..BUSHING	.102C003P02	....1
*7	..CUSHION MOUNT RING	.469C004P02	....1	40	..”O” RING	.614C028P01	....1
8	..OUTLET SCREW	.636C017P03	....2	41	..SCREW	.636C026P01	....4
9	..OUTLET FLANGE	.249C009P01	....1	42	..COLLAR	.154C005P02	....1
10	..OUTLET ELBOW	.673C015P01	....1	43	..SWITCH COVER	.174C021P01	....1
11	..RUBBER OUTLET GASKET	.269C038P01	....1	44	..SCREW	.636C014P03	....3
12	..GRIND RING	.614C066PO2	....2	45	..SCREW	.636C019P01	....2
	DRAIN HOUSING ASSEMBLY	.311C080S02	....1	46	..CHERRY SWITCH	.695C003P02	....1
*13	..DRAIN HOUSING	.311C080P01	....1	47	..SWITCH BRACKET	.072C001P01	....1
*14	..THRUST WASHER	.789C041P01	....1	48	..JAM NUT	.479C010P01	....1
*15	..WATER SEAL	.645C006P01	....1	49	..SPRING	.675C001P01	....1
*16	..SPACER SEAL	.102C005P01	....1	50	..WASHER	.789C011P01	....1
	TURNTABLE ASSEMBLY	.258C032S02	....1	51	..WASHER	.789C013P01	....1
*17	..SLINGER	.789C034P03	....1	52	..RETAINER	.612C007P01	....1
*18	..O-RING	.645C004P01	....1	53	..BUSHING	.287C002P01	....1
*19	..TURNTABLE	.258C032P02	....1	54	..BUSHING	.102C004P01	....2
20	..HOPPER ASSEMBLY	.311C076S01	....1	55	..CONNECTOR FLAG	.711C010P01	....2
21	..HOPPER SCREW	.636C023P01	....4	56	..CONDUIT CLAMP	.142C001P01	....1
22	..ADAPTER	.614C061P02	....1	57	..SCREW	.636C015P18	....1
23	..GASKET	.269C014P01	....1	58	..CONDUIT	.163C003P02	....1
24	..WASHER	.789C035P02	....1	59	..LEAD WIRE (WHITE)	.299C008P11	....1
25	..ARMATURE ASSEMBLY.	.626C035P03	....1	60	..LEAD WIRE (WHITE)	.299C008P10	....1
26	..MOTOR STUD	.687C003P01	....1	61	..SPLICE	.711C009P01	....1
27	..MOTOR STUD	.687C003P02	....1	62	..GROUND WIRE	.299C005S07	....1
28	..MOTOR SHELL ASSEMBLY.	.681C031S12	....1	63	..CONDUIT CLAMP	.142C002P01	....1
	ENDBELL ASSEMBLY	.311C081S122	....1	63	..SCREW	.636C014P18	....1
*29	..ENDBELL	.311C081S53	....1	†64	..SINKFLANGE GASKET (THICK)	.269C032P01	....1
*30	..MTR. BRUSH & BRUSH SPRING ASSY.	.027C029S02	....1				
31	..NUT	.479C019P01	....2				
32	..INSPECTION PLATE	.554C032P01	....1				

†NOT SHOWN

\*PART OF AN ASSEMBLY, BUT CAN BE PURCHASED SEPARATELY.



# Waste King

## Legend Series

by Anaheim Manufacturing Company

### PARTS LIST MODEL 2600TC

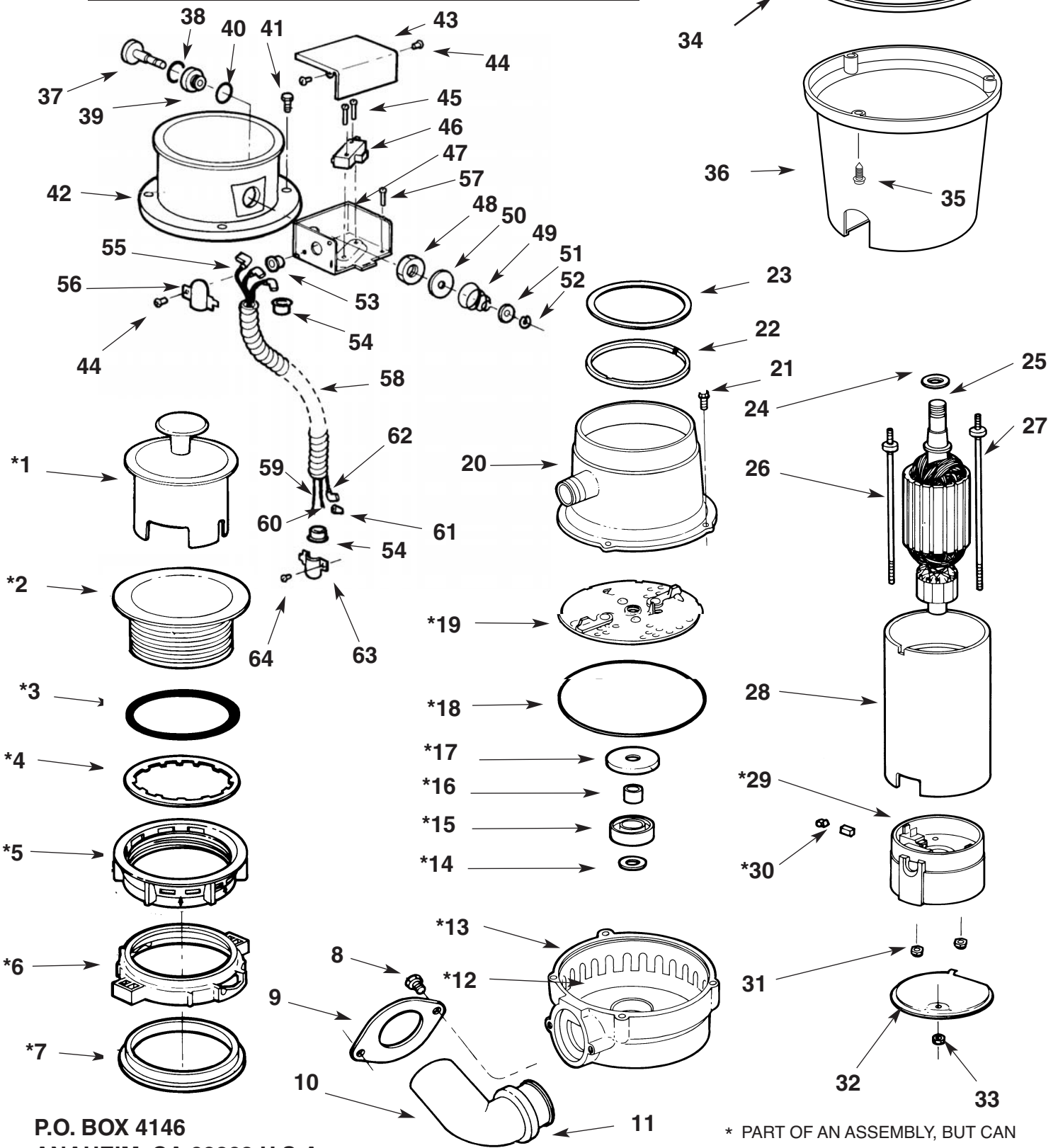

P.O. BOX 4146  
ANAHEIM, CA 92803 U.S.A.

\* PART OF AN ASSEMBLY, BUT CAN BE PURCHASED SEPARATELY.

ITEM NO.	DESCRIPTION	MODEL L-3200	QTY. PER UNIT
MOUNT ASSEMBLY		249C019S242	1
*1	.STOPPER	174C067S01	1
*2	.SPLASH GUARD	614C069P01	1
*3	.SINKFLANGE & CAP ASSEMBLY.	249C014S35	1
*4	.RUBBER GASKET	269C031P01	1
*5	.FIBER GASKET (WAXED)	269C033P01	1
*6	.SUPPORT RING	614C072P01	1
*7	.MOUNT RING	614C059P02	1
*8	.CUSHION MOUNT RING	469C004P02	1
9	.OUTLET SCREW	636C017P03	2
10	.OUTLET FLANGE	249C009P01	1
11	.OUTLET ELBOW	673C015P01	1
12	.RUBBER OUTLET GASKET	269C038P01	1
13	.GRIND RING	614C060P01	1
DRAIN HOUSING ASSEMBLY		311C082S01	1
*14	.DRAIN HOUSING	311C082P01	1
*15	.THRUST WASHER	789C041P01	1
*16	.WATER SEAL	645C006P01	1
*17	.SPACER SEAL	102C005P01	1
TURNTABLE ASSEMBLY		258C032S04	1
*18	.SLINGER	789C034P03	1
*19	.O-RING	645C005P01	1
*20	.TURNTABLE	258C032P02	1
21	.HOPPER ASSEMBLY	311C070S01	1
22	.HOPPER SCREW	636C023P01	6
23	.WASHER	789C035P05	1
24	.ARMATURE ASSEMBLY.	626C035P03	1
25	.MOTOR STUD	687C003P01	1
26	.MOTOR STUD	687C003P02	1
27	.MOTOR SHELL ASSEMBLY.	681C031S14	1
ENDBELL ASSEMBLY		311C081S04	1
*28	.ENDBELL	311C081P01	1
*29	.MOTOR BRUSH & BRUSH SPRING ASSEMBLY	027C029S02	1
30	.NUT	479C019P01	2
31	.INSPECTION PLATE	554C032P01	1
32	.NUT	479C021P01	1
33	.UPPER SHELL	806C062P05	1
34	.LOWER SHELL	806C063P05	1
35	.SHELL SCREW	636C024P01	3
†36	.SINKFLANGE GASKET-WAXED (THICK)	269C032P01	1

†NOT SHOWN

\*PART OF AN ASSEMBLY, BUT CAN BE PURCHASED SEPARATELY.



# Waste King Legend Series

by Anaheim Manufacturing Company

## PARTS LIST MODEL 3200

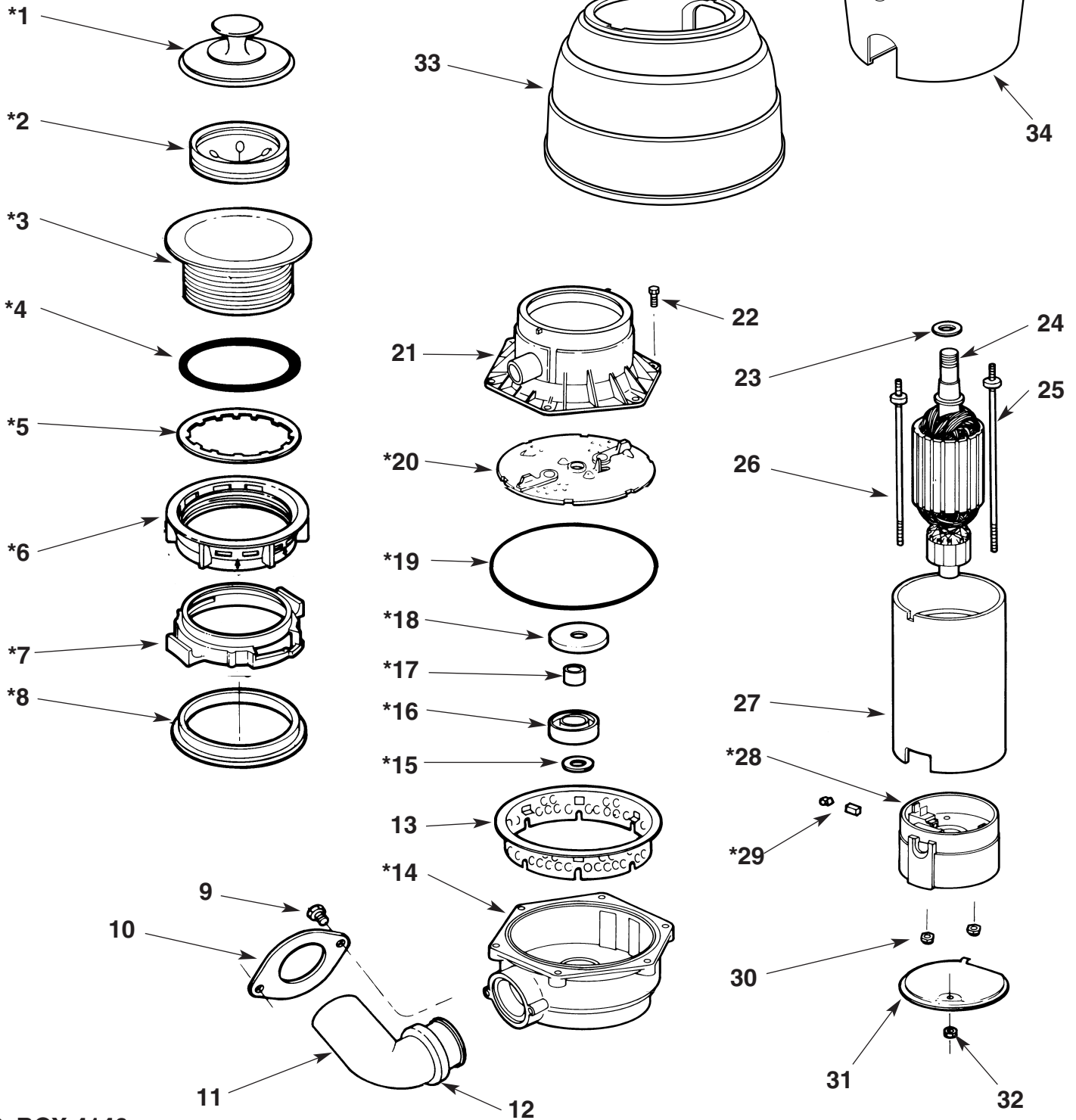

P.O. BOX 4146  
ANAHEIM, CA 92803 U.S.A.

\* PART OF AN ASSEMBLY, BUT CAN BE PURCHASED SEPARATELY.



ITEM NO.	DESCRIPTION	MODEL L-3300	QTY. PER UNIT
MOUNT ASSEMBLY		.249C019S242	1
*1	STOPPER	.174C067S01	1
*2	SPLASH GUARD	.614C069P01	1
*3	SINKFLANGE & CAP ASSEMBLY	.249C014S35	1
*4	RUBBER GASKET	.269C031P01	1
*5	FIBER GASKET (WAXED)	.269C033P01	1
*6	SUPPORT RING	.614C072P01	1
*7	MOUNT RING	.614C059P02	1
*8	CUSHION MOUNT RING	.469C004P02	1
9	OUTLET SCREW	.636C017P03	2
10	OUTLET FLANGE	.249C009P01	1
11	OUTLET ELBOW	.673C015P01	1
12	RUBBER OUTLET GASKET	.269C038P01	1
13	GRIND RING	.614C060P01	1
DRAIN HOUSING ASSEMBLY		.311C082S01	1
*14	DRAIN HOUSING	.311C082P01	1
*15	THRUST WASHER	.789C041P01	1
*16	WATER SEAL	.645C006P01	1
*17	SPACER SEAL	.102C005P01	1
TURNTABLE ASSEMBLY		.258C032S03	1
*18	SLINGER	.789C034P04	1
*19	O-RING	.645C005P01	1
*20	TURNTABLE	.258C032P02	1
21	HOPPER ASSEMBLY	.311C070S01	1
22	HOPPER SCREW	.636C023P01	6
23	WASHER	.789C035P02	1
24	ARMATURE ASSEMBLY	.626C035P05	1
25	MOTOR STUD	.687C003P02	1
26	MOTOR STUD	.687C003P03	1
27	MOTOR SHELL ASSEMBLY	.681C031S14	1
ENDBELL ASSEMBLY		.311C081S04	1
*28	ENDBELL	.311C081P01	1
*29	MOTOR BRUSH & BRUSH SPRING ASSEMBLY	.027C029S02	1
30	NUT	.479C019P01	2
31	INSPECTION PLATE	.554C032P01	1
32	NUT	.479C021P01	1
33	UPPER SHELL	.806C064P05	1
34	LOWER SHELL	.806C065P05	1
35	SHELL SCREW	.636C024P01	3
†36	SINKFLANGE GASKET-WAXED (THICK)	.269C032P01	1

†NOT SHOWN

\*PART OF AN ASSEMBLY, BUT CAN BE PURCHASED SEPARATELY.



# Waste King

*Legend Series*  
by Anaheim Manufacturing Company

## PARTS LIST MODEL 3300

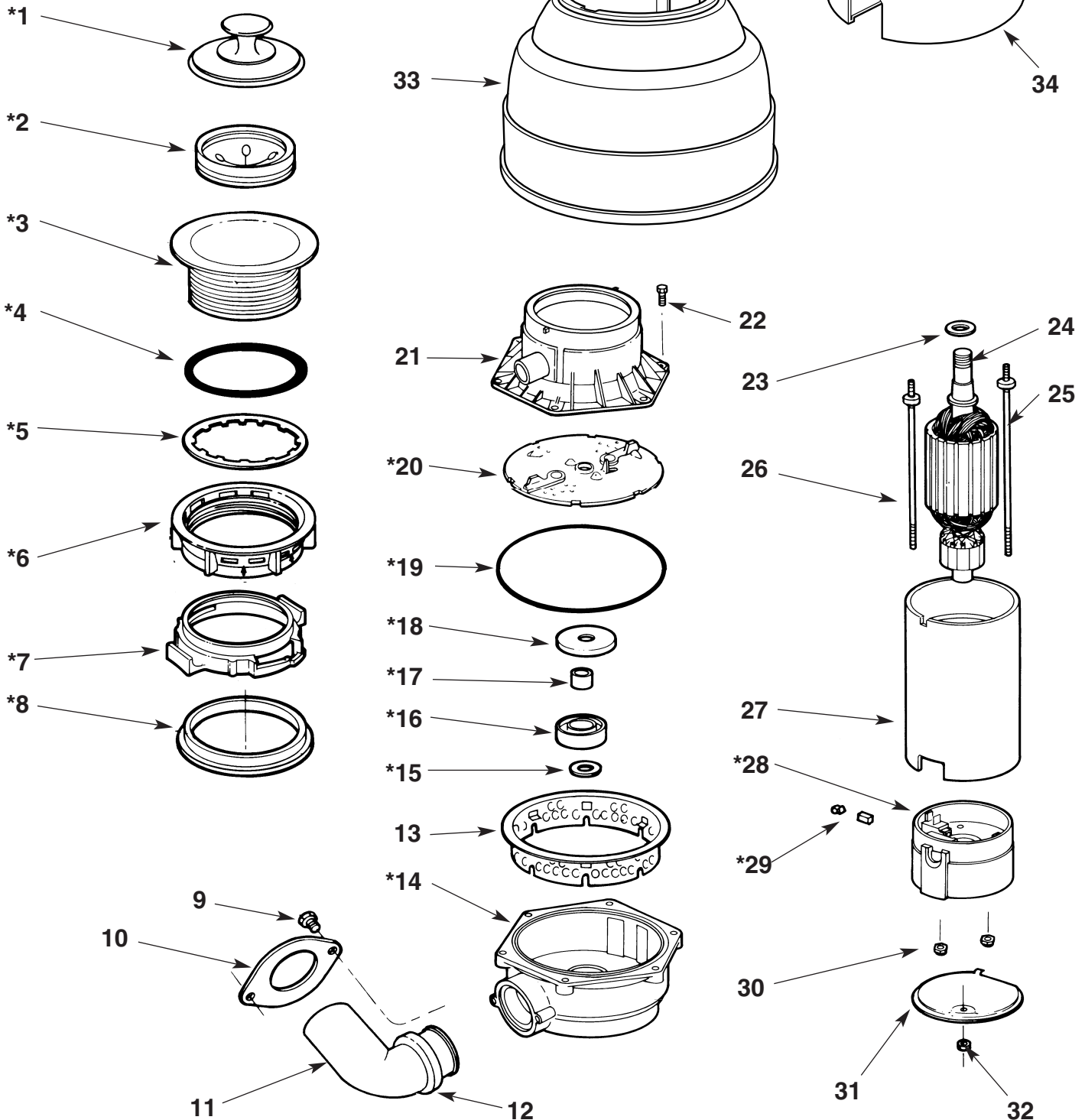

P.O. BOX 4146  
ANAHEIM, CA 92803 U.S.A.

\* PART OF AN ASSEMBLY, BUT CAN BE PURCHASED SEPARATELY.

## MODEL L-5000TC

ITEM #	DESCRIPTION	PART #	QTY	ITEM #	DESCRIPTION	PART #	QTY
	MOUNT ASSEMBLY	.249C019S75BF	1	33	NUT	.479C021P01	1
*1	STOPPER	.174C066S02	1	34	UPPER SHELL	.806C064P51	1
*2	SINKFLANGE & CAP ASSY.	.249C014S35	1	35	LOWER SHELL	.806C065P01	1
*3	RUBBER GASKET	.269C031P01	1	36	SHELL SCREW	.636C014P19	3
*4	FIBER GASKET (WAXED)	.269C033P01	1	37	PLUNGER BUTTON	.106C004P01	1
*5	SUPPORT RING	.614C072P01	1	38	"O" RING	.614C027P01	2
*6	MOUNT RING	.614C059P02	1	39	BUSHING	.102C003P02	1
*7	CUSHION MOUNT RING	.469C004P02	1	40	"O" RING	.614C028P01	1
8	OUTLET SCREW	.636C017P03	2	41	SCREW	.636C026P01	4
9	OUTLET FLANGE	.249C009P01	1	42	COLLAR	.154C005P02	1
10	OUTLET ELBOW	.673C015P01	1	43	SWITCH COVER	.174C021P01	1
11	RUBBER OUTLET GASKET	.269C038P01	1	44	SCREW	.636C014P03	3
12	GRIND RING	.614C060P01	1	45	SCREW	.636C019P01	2
	DRAIN HOUSING ASSEMBLY	.311C082S01	1	46	CHERRY SWITCH	.695C003P02	1
*13	DRAIN HOUSING	.311C082P01	1	47	SWITCH BRACKET	.072C001P01	1
*14	THRUST WASHER	.789C041P01	1	48	JAM NUT	.479C010P01	1
*15	WATER SEAL	.645C006P01	1	49	SPRING	.675C001P01	1
*16	SPACER SEAL	.102C005P01	1	50	WASHER	.789C011P01	1
	TURNTABLE ASSEMBLY	.258C032S04	1	51	WASHER	.789C013P01	1
*17	SLINGER	.789C034P03	1	52	RETAINER	.612C007P01	1
*18	O-RING	.645C005P01	1	53	BUSHING	.287C002P01	1
*19	TURNTABLE	.258C032P02	1	54	BUSHING	.102C004P01	2
20	HOPPER ASSEMBLY	.311C070S01	1	55	CONNECTOR FLAG	.711C010P01	2
21	HOPPER SCREW	.636C023P01	6	56	CONDUIT CLAMP	.142C001P01	1
22	ADAPTER	.614C061P02	1	57	GROUND WIRE	.299C005S08	1
23	GASKET	.269C014P01	1	58	CONDUIT	.163C003P01	1
24	WASHER	.789C035P02	1	59	LEAD WIRE (WHITE)	.299C008P05	1
25	ARMATURE ASSEMBLY.	.626C035P05	1	60	LEAD WIRE (WHITE)	.299C008P11	1
26	MOTOR STUD	.687C003P03	1	61	SPLICE	.711C009P01	1
27	MOTOR STUD	.687C003P02	1	62	GROUND SCREW	.636C027P01	1
28	MOTOR SHELL ASSEMBLY.	.681C031S14	1	63	CONDUIT CLAMP	.142C002P01	1
	ENDBELL ASSEMBLY	.311C081S81	1	64	SCREW	.636C014P18	1
*29	ENDBELL	.311C081P01	1	†65	SINKFLANGE GASKET (THICK)	.269C032P01	1
*30	MTR. BRUSH & BRUSH SPRING ASSY	.027C029S02	1				
31	NUT	.479C019P01	2				
32	INSPECTION PLATE	.554C032P01	1				

†NOT SHOWN

\*PART OF AN ASSEMBLY, BUT CAN BE PURCHASED SEPARATELY.



# Waste King

## Legend Series

by Anaheim Manufacturing Company

### PARTS LIST MODEL 5000TC

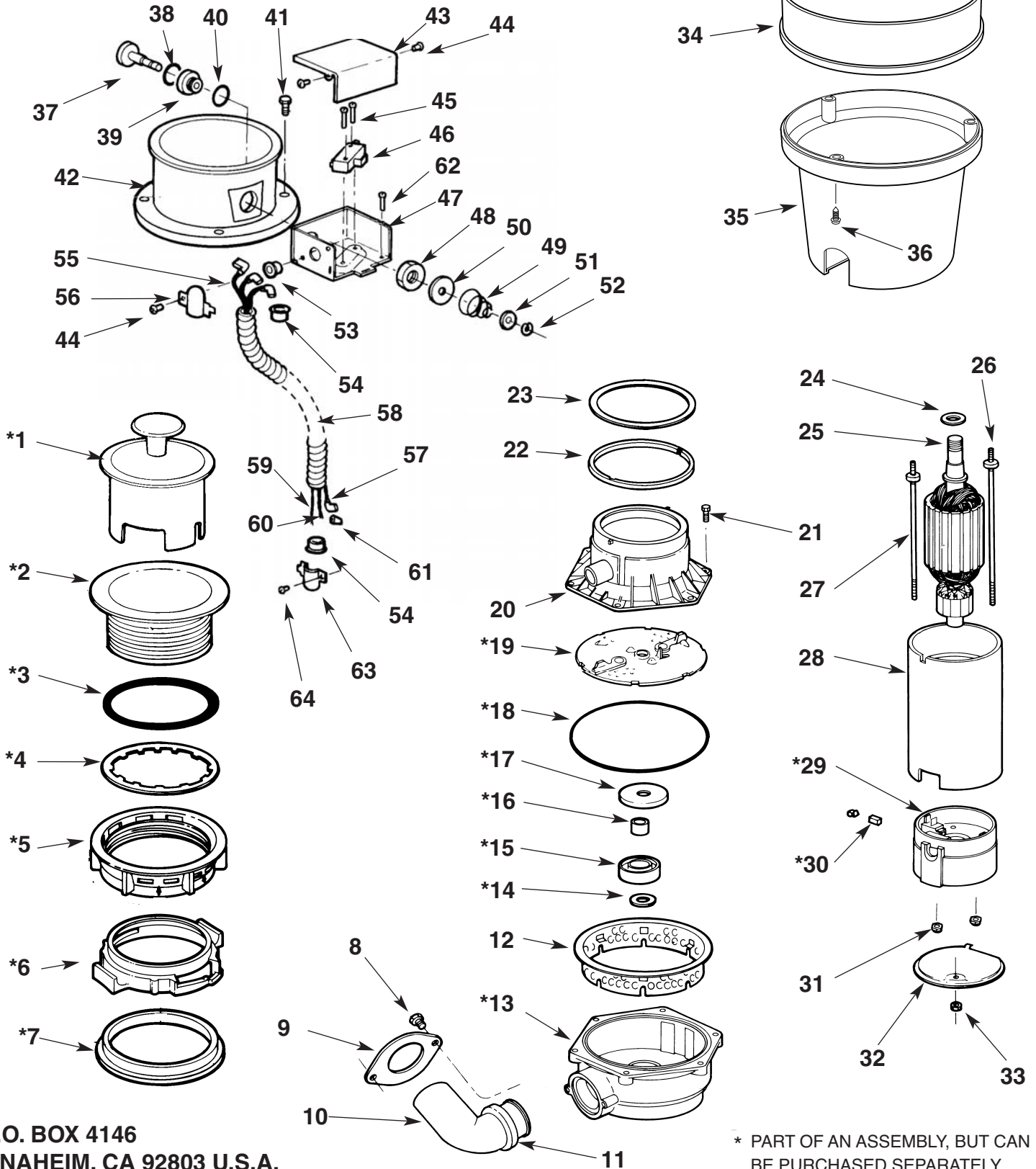

P.O. BOX 4146  
ANAHEIM, CA 92803 U.S.A.

\* PART OF AN ASSEMBLY, BUT CAN BE PURCHASED SEPARATELY.

ITEM NO.	DESCRIPTION	MODEL L-8000	QTY. PER UNIT
MOUNT ASSEMBLY		.249C019S242	.1
*1	.STOPPER	.174C067S01	.1
*2	.SPLASH GUARD	.614C069P01	.1
*3	.SINK FLANGE & CAP ASSEMBLY	.249C014S35	.1
*4	.RUBBER GASKET	.269C031P01	.1
*5	.FIBER GASKET (WAXED)	.269C033P01	.1
*6	.SUPPORT RING	.614C072P01	.1
*7	.MOUNT RING	.614C059P02	.1
*8	.CUSHION MOUNT RING	.469C004P02	.1
9	.OUTLET SCREW	.636C017P03	.2
10	.OUTLET FLANGE	.249C009P01	.1
11	.OUTLET ELBOW	.673C015P01	.1
12	.RUBBER OUTLET GASKET	.269C038P01	.1
13	.GRIND RING	.614C060P01	.1
DRAIN HOUSING ASSEMBLY		.311C082S01	.1
*14	.DRAIN HOUSING	.311C082P01	.1
*15	.THRUST WASHER	.789C041P01	.1
*16	.WATER SEAL	.645C006P01	.1
*17	.SPACER	.102C005P01	.1
TURNTABLE ASSEMBLY		.258C032S04	.1
*18	.SLINGER	.789C034P03	.1
*19	.O-RING	.645C005P01	.1
*20	.TURNTABLE	.258C032P02	.1
21	.HOPPER ASSEMBLY	.311C070P01	.1
22	.HOPPER SCREW	.636C023P01	.6
23	.WASHER	.789C035P02	.1
24	.ARMATURE ASSEMBLY	.626C035P16	.1
25	.MOTOR STUD	.687C003P05	.1
26	.MOTOR STUD	.687C003P06	.1
27	.MOTOR SHELL ASSEMBLY	.681C031P15	.1
ENDBELL ASSEMBLY		.311C081S10	.1
*28	.END BELL	.311C081P01	.1
*29	.MOTOR BRUSH & BRUSH SPRING ASSEMBLY	.027C029S02	.1
30	.NUT	.479C019P01	.2
31	.INSPECTION PLATE	.554C032P01	.1
32	.NUT	.479C021P01	.1
33	.UPPER SHELL	.806C064P01	.1
34	.LOWER SHELL	.806C066P01	.1
35	.SHELL SCREW	.636C024P01	.3
†36	.SINK FLANGE GASKET-WAXED (THICK)	.269C032P01	.1

†NOT SHOWN

\*PART OF AN ASSEMBLY, BUT CAN BE PURCHASED SEPARATELY.



# Waste King Legend Series

by Anaheim Manufacturing Company

## PARTS LIST MODEL 8000

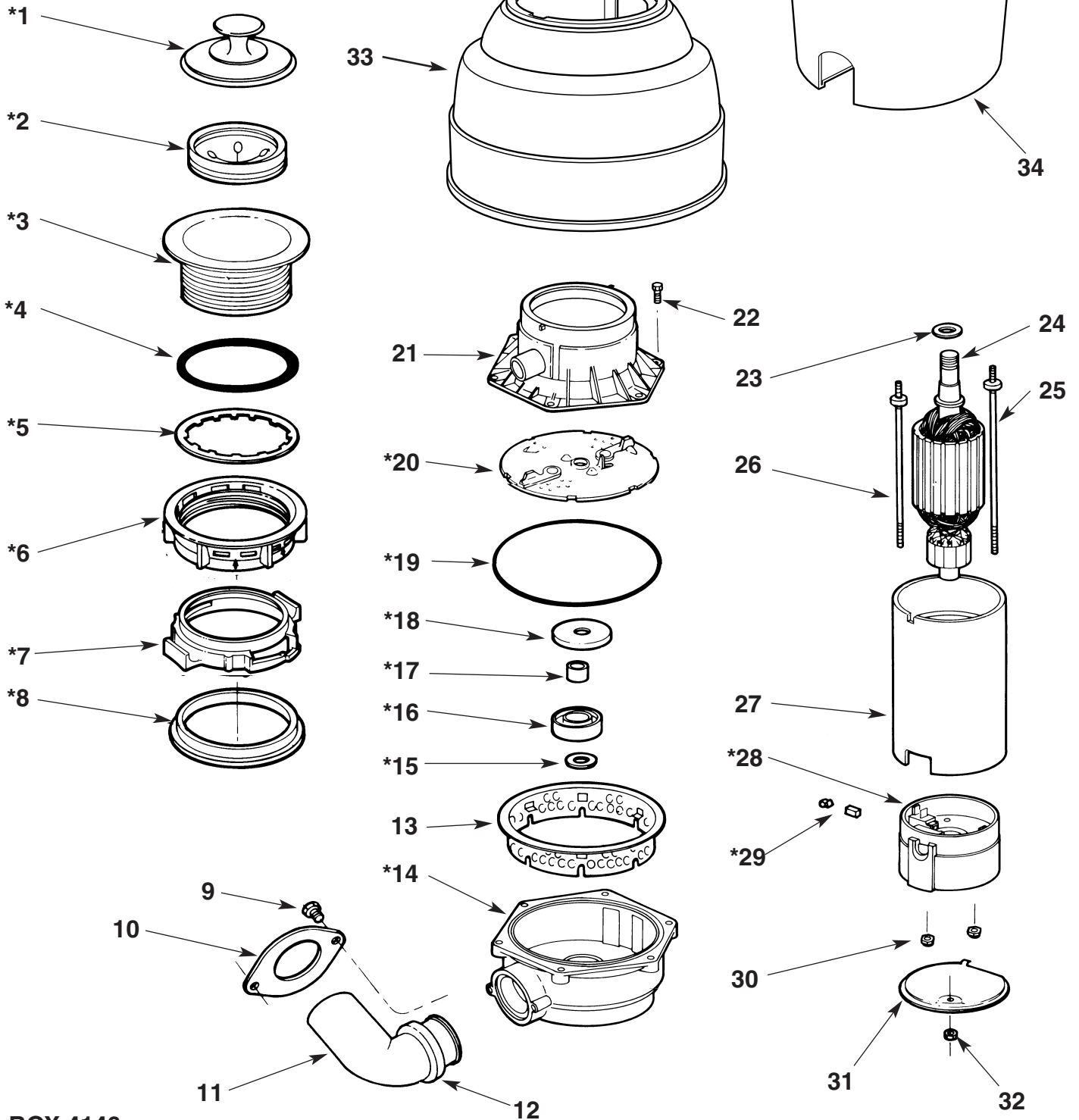

P.O. BOX 4146  
ANAHEIM, CA 92803 U.S.A.

\* PART OF AN ASSEMBLY, BUT CAN BE PURCHASED SEPARATELY.

## MODEL L-8000TC

ITEM #	DESCRIPTION	PART #	QTY	ITEM #	DESCRIPTION	PART #	QTY
	MOUNT ASSEMBLY	.249C019S75BF	1	33	NUT	.479C021P01	1
*1	STOPPER	.174C066S02	1	34	UPPER SHELL	.806C064P51	1
*2	SINKFLANGE & CAP ASSY.	.249C014S35	1	35	LOWER SHELL	.806C066P01	1
*3	RUBBER GASKET	.269C031P01	1	36	SHELL SCREW	.636C014P19	3
*4	FIBER GASKET (WAXED)	.269C033P01	1	37	PLUNGER BUTTON	.106C004P01	1
*5	SUPPORT RING	.614C072P01	1	38	"O" RING	.614C027P01	2
*6	MOUNT RING	.614C059P02	1	39	BUSHING	.102C003P02	1
*7	CUSHION MOUNT RING	.469C004P02	1	40	"O" RING	.614C028P01	1
8	OUTLET SCREW	.636C017P03	2	41	SCREW	.636C026P01	4
9	OUTLET FLANGE	.249C009P01	1	42	COLLAR	.154C005P02	1
10	OUTLET ELBOW	.673C015P01	1	43	SWITCH COVER	.174C021P01	1
11	RUBBER OUTLET GASKET	.269C038P01	1	44	SCREW	.636C014P03	3
12	GRIND RING	.614C060P01	1	45	SCREW	.636C019P01	2
	DRAIN HOUSING ASSEMBLY	.311C082S01	1	46	CHERRY SWITCH	.695C003P02	1
*13	DRAIN HOUSING	.311C082P01	1	47	SWITCH BRACKET	.072C001P01	1
*14	THRUST WASHER	.789C041P01	1	48	JAM NUT	.479C010P01	1
*15	WATER SEAL	.645C006P01	1	49	WASHER	.789C011P01	1
*16	SPACER SEAL	.102C005P01	1	50	SPRING	.675C001P01	1
	TURNTABLE ASSEMBLY	.258C032S04	1	51	WASHER	.789C013P01	1
*17	SLINGER	.789C034P03	1	52	RETAINER	.612C007P01	1
*18	O-RING	.645C005P01	1	53	BUSHING	.287C002P01	1
*19	TURNTABLE	.258C032P02	1	54	BUSHING	.102C004P01	2
20	HOPPER ASSEMBLY	.311C070S01	1	55	CONNECTOR FLAG	.711C010P01	2
21	HOPPER SCREW	.636C023P01	6	56	CONDUIT CLAMP	.142C001P01	1
22	ADAPTER	.614C061P02	1	57	GROUND WIRE ASSEMBLY	.299C005S08	1
23	GASKET	.269C014P01	1	58	CONDUIT	.163C003P01	1
24	WASHER	.789C035P02	1	59	LEAD WIRE (WHITE)	.299C008P06	1
25	ARMATURE ASSEMBLY	.626C035P16	1	60	LEAD WIRE (WHITE)	.299C008P11	1
26	MOTOR STUD	.687C003P05	1	61	SPLICE	.711C009P01	1
27	MOTOR STUD	.687C003P06	1	62	GROUND SCREW	.636C027P01	1
28	MOTOR SHELL ASSEMBLY	.681C031S15	1	63	CONDUIT CLAMP	.142C002P01	1
	ENDBELL ASSEMBLY	.311C081S09	1	64	SCREW	.636C014P18	1
*29	ENDBELL	.311C081P01	1	†65	SINKFLANGE GASKET (THICK)	.269C032P01	1
*30	MTR. BRUSH & BRUSH SPRING ASSY	.027C029S02	1				
31	NUT	.479C019P01	2				
32	INSPECTION PLATE	.554C032P01	1				

†NOT SHOWN

\*PART OF AN ASSEMBLY, BUT CAN BE PURCHASED SEPARATELY.



# Waste King

## Legend Series

by Anaheim Manufacturing Company

### PARTS LIST MODEL 8000TC

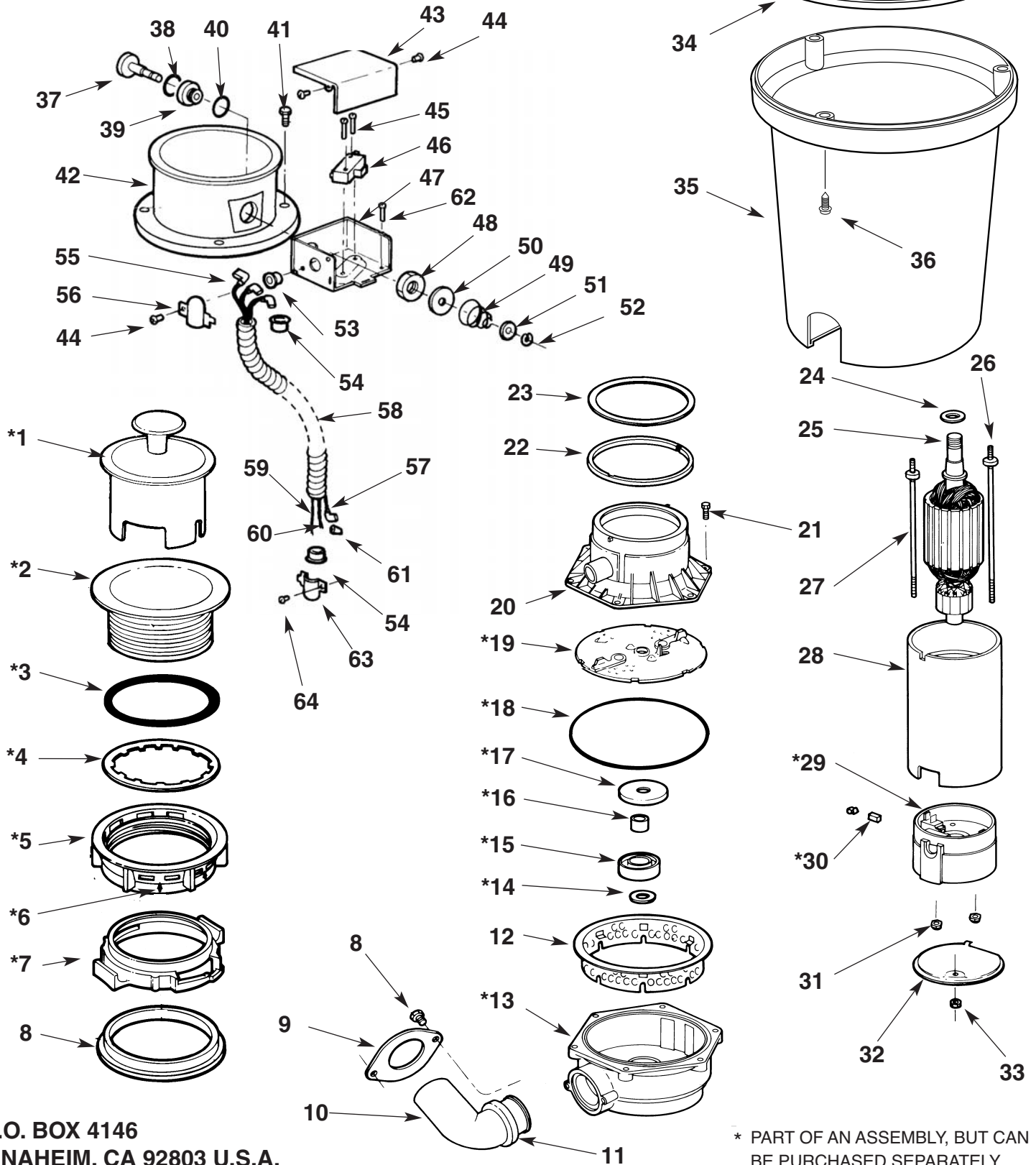

P.O. BOX 4146  
ANAHEIM, CA 92803 U.S.A.

\* PART OF AN ASSEMBLY, BUT CAN BE PURCHASED SEPARATELY.