

# REAR AXLE & REAR SUSPENSION

## SECTION **RA**

GI

MA

EM

LC

EF &  
EC

FE

CL

MT

AT

TF

PD

FA

**RA**

BR

ST

BF

HA

EL

IDX

## CONTENTS

<b>PRECAUTIONS AND PREPARATION</b> .....	2	<b>REAR SUSPENSION</b> .....	13
Precautions.....	2	Shock Absorber.....	14
Special Service Tools .....	2	Leaf Spring .....	14
Commercial Service Tools .....	2	<b>REAR AXLE AND REAR SUSPENSION</b> .....	16
<b>REAR AXLE AND REAR SUSPENSION</b> .....	3	5-link Type .....	16
<b>ON-VEHICLE SERVICE</b> .....	4	<b>REAR SUSPENSION</b> .....	17
Rear Axle and Rear Suspension Parts.....	4	5-link Type .....	17
Rear Wheel Bearing .....	4	<b>SERVICE DATA AND SPECIFICATIONS (SDS)</b> .....	20
<b>REAR AXLE</b> .....	5	General Specifications.....	20
Drum Brake Type.....	5	Inspection and Adjustment.....	21
Disc Brake Type.....	9		

## PRECAUTIONS AND PREPARATION

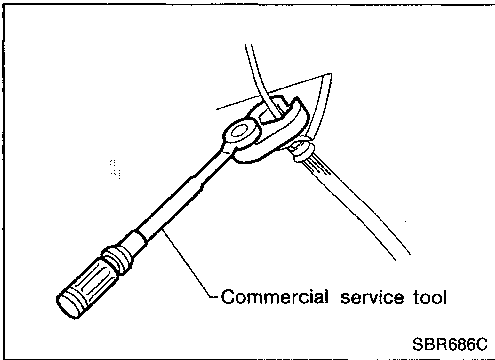

### Precautions

- When installing rubber parts, final tightening must be carried out under unladen condition\* with tires on ground.  
\*: Fuel, radiator coolant and engine oil full. Spare tire, jack, hand tools and mats in designated positions.
- Use flare nut wrench when removing or installing brake tubes.
- After installing removed suspension parts, check wheel alignment and adjust if necessary.
- Always torque brake lines when installing.

### Special Service Tools

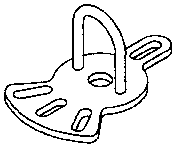
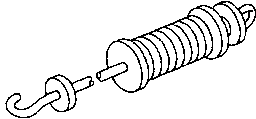
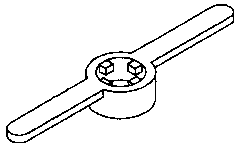
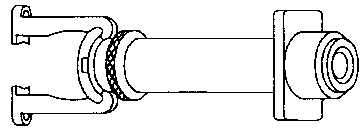
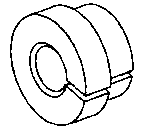
Tool number (Kent-Moore No.) Tool name	Description
KV40101000 (J25604-01) Axle stand	 Removing rear axle shaft NT159
ST36230000 (J25840-A) Sliding hammer	 Removing rear axle shaft NT126
ST38020000 ( — ) Bearing lock nut wrench	 Removing wheel bearing lock nut NT160
HT72480000 (J25852-B) Rear axle shaft bearing puller	 Removing wheel bearing NT161
ST37840000 ( — ) Rear axle shaft guide	 Installing rear axle shaft NT162

### Commercial Service Tools

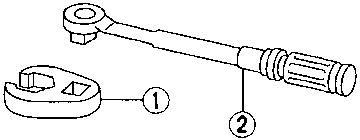
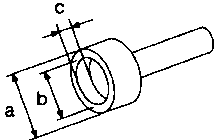
Tool name	Description
① Flare nut crows foot ② Torque wrench	 Removing and installing each brake piping NT223
Rear axle oil seal drift	 Installing oil seal NT163 a: 74 mm (2.91 in) dia. b: 68 mm (2.68 in) dia. c: 10 mm (0.39 in)

# REAR AXLE AND REAR SUSPENSION

## 2WD TRUCK MODELS

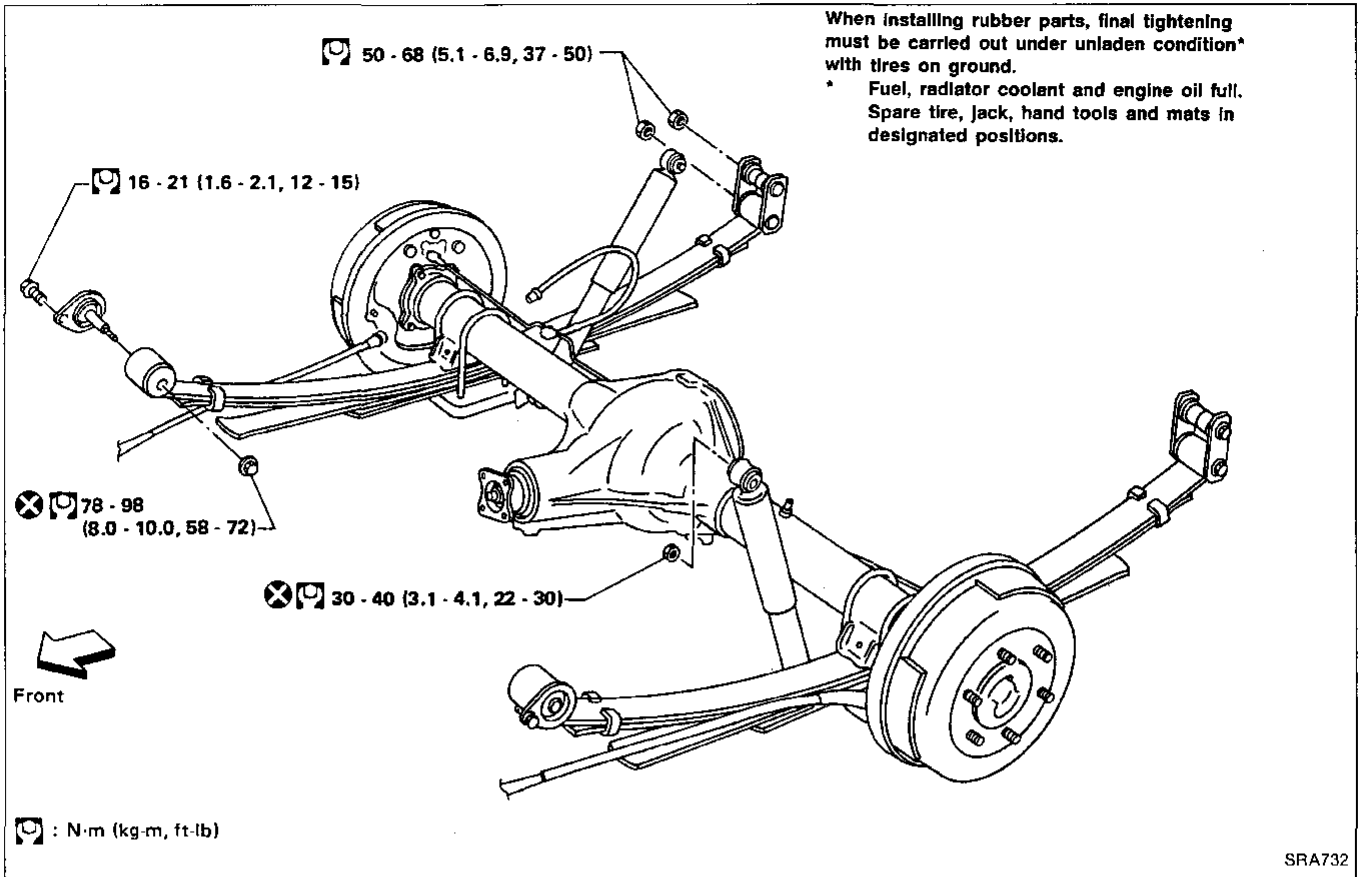

## 4WD TRUCK MODELS

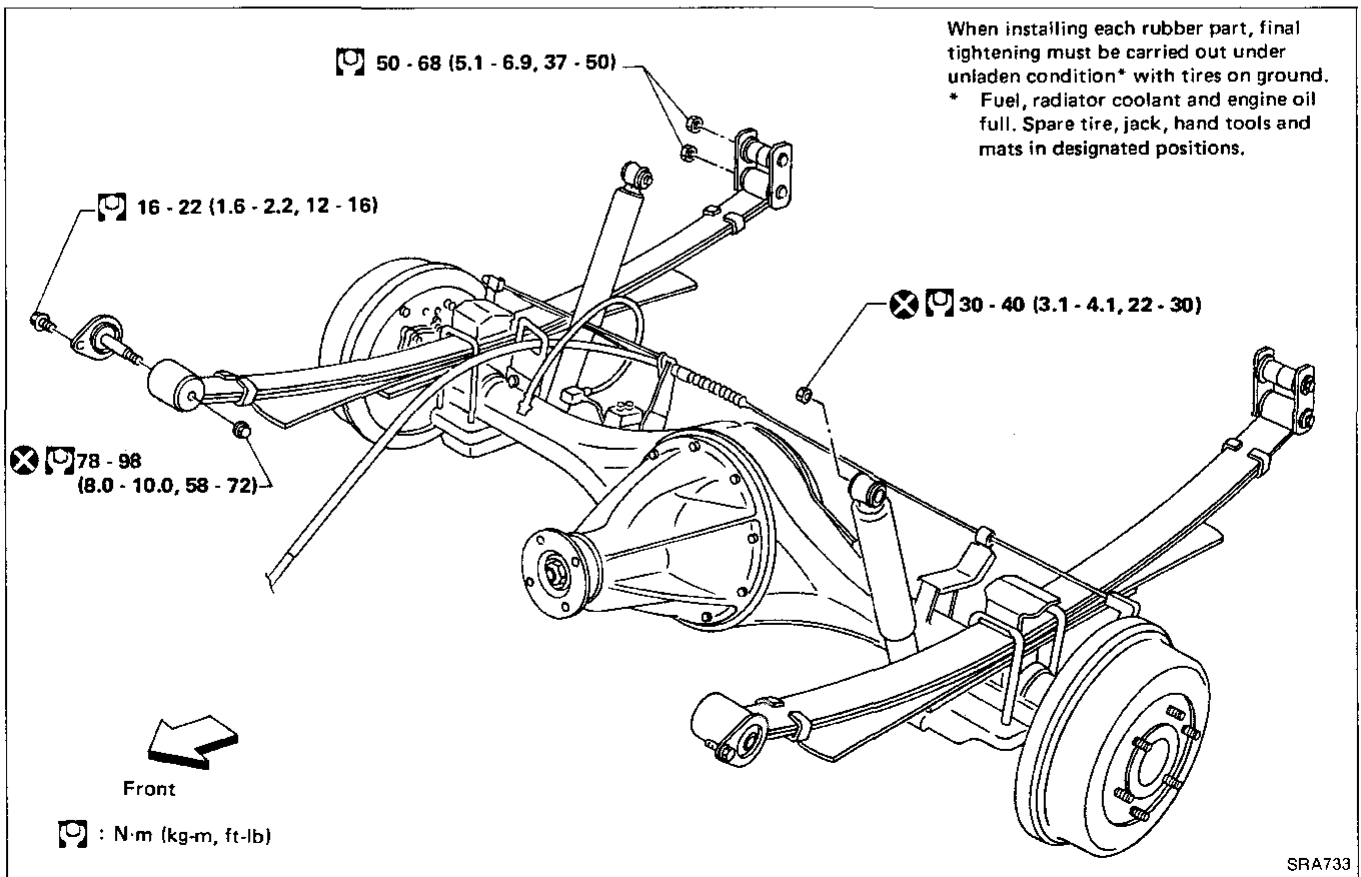

GE  
 MA  
 EM  
 LC  
 EF & EC  
 FE  
 CL  
 MT  
 AT  
 TF  
 PD  
 FA  
 RA  
 BR  
 ST  
 BF  
 HA  
 EL  
 IDX

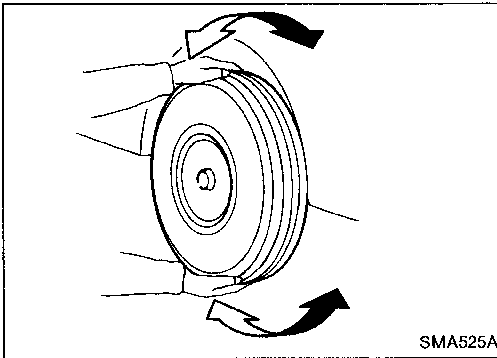

## Rear Axle and Rear Suspension Parts

Check rear axle and rear suspension parts for looseness, wear or damage.

- Shake each rear wheel to check for excessive play.

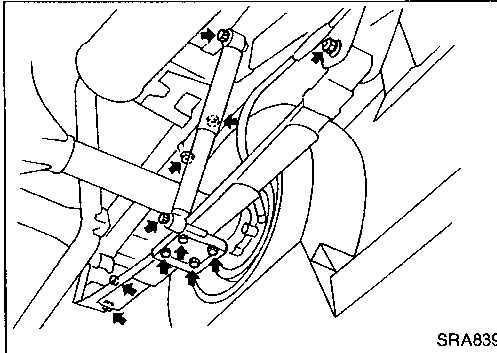

- Retighten all nuts and bolts to the specified torque.  
**Tightening torque: Refer to REAR SUSPENSION (RA-13).**

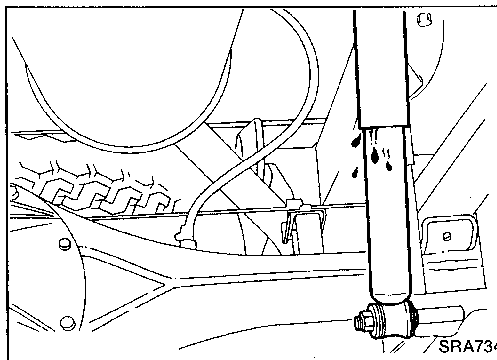

- Check shock absorber for oil leakage or other damage.
- Check shock absorber bushing for excessive wear or other damage.

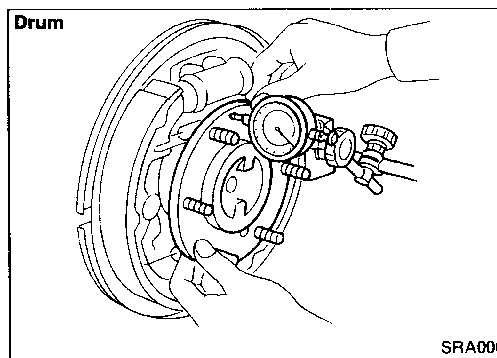

## Rear Wheel Bearing

- Check that wheel bearings operate smoothly.
- Check axial end play.

**Axial end play:**  
**Refer to SDS (RA-21).**

# REAR AXLE

## Drum Brake Type COMPONENTS

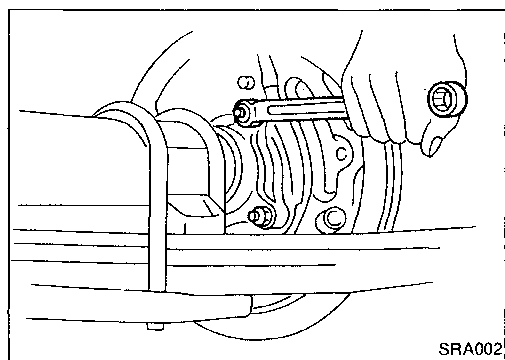
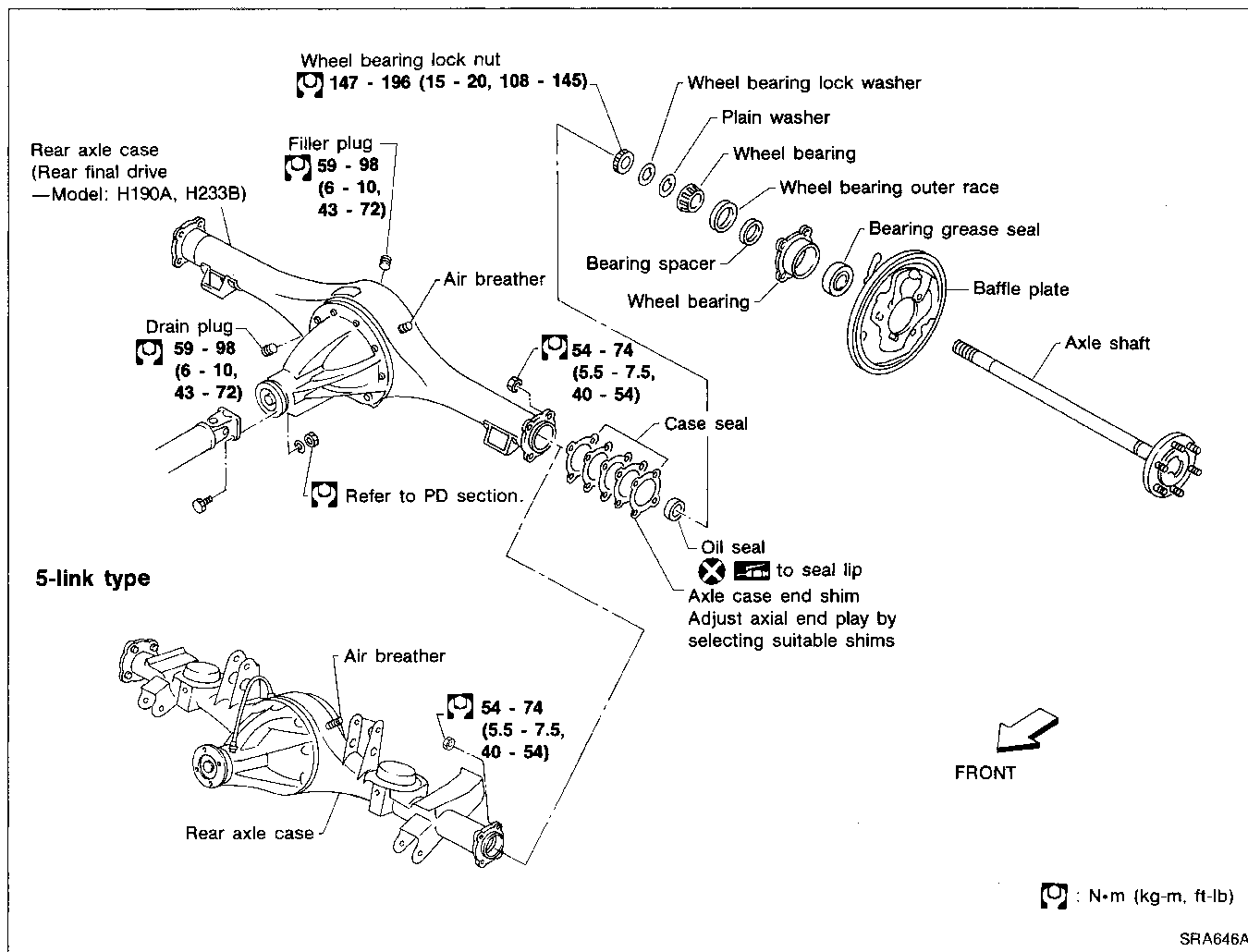

### REMOVAL

- Disconnect parking brake cable and brake tube.
- Remove nuts securing wheel bearing cage with baffle plate.

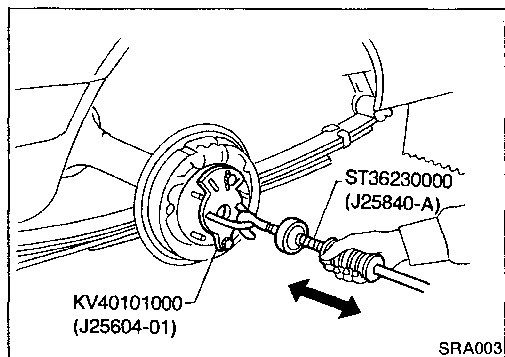

- Draw out axle shaft with Tool.
- When drawing out axle shaft, be careful not to damage oil seal.**
- Remove oil seal.
- Do not reuse oil seal once it is removed.  
Always install new one.**

## REAR AXLE

### Drum Brake Type (Cont'd)

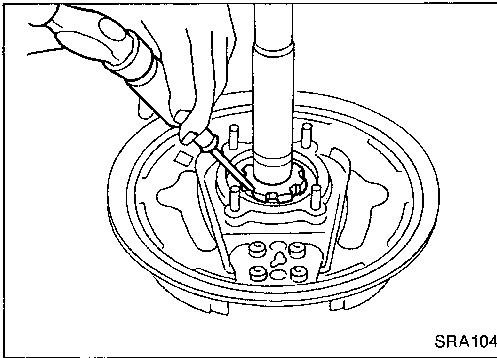

- Unbend lock washer with a screwdriver.

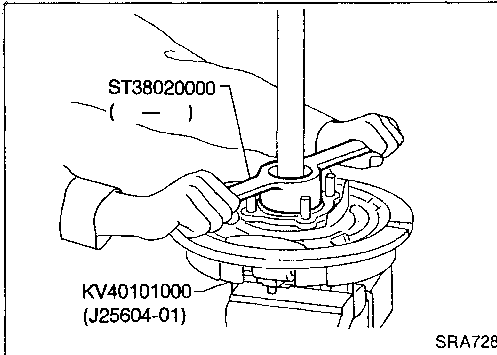

- Remove bearing lock nut with Tool.

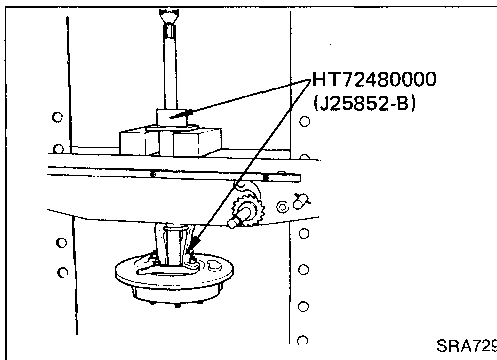

- Remove wheel bearing together with bearing cage and baffle plate from axle shaft.

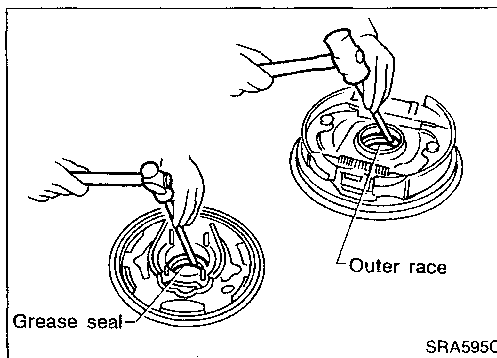

- Remove grease seal in bearing cage with suitable bar.
- Remove wheel bearing outer race with a brass drift.

## REAR AXLE

### Drum Brake Type (Cont'd)

#### INSPECTION

##### Axle shaft

- Check axle shaft for straightness, cracks, damage, wear or distortion. Replace if necessary.

##### Wheel bearing

- Make sure wheel bearing rolls freely and is free from noise, cracks, pitting or wear.

##### Axle case

- Check axle case for yield, deformation or cracks. Replace if necessary.

#### INSTALLATION

- Install wheel bearing outer race with a brass drift.
- Install a new grease seal in bearing cage.

**After installing new grease seal, coat sealing lip with multi-purpose grease.**

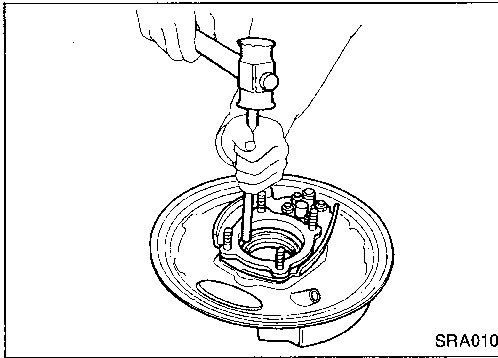

CI

MA

EM

LC

EF &  
EC

FE

CL

- Install bearing spacer with chamfer side facing axle shaft flange.

MT

AT

TF

PD

FA

RA

BR

ST

BF

HA

EL

IDX

963

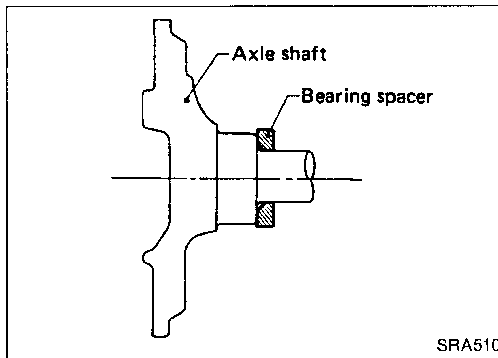

- Install wheel bearing inner race with a brass drift.  
**Coat each bearing cone with multi-purpose grease.**

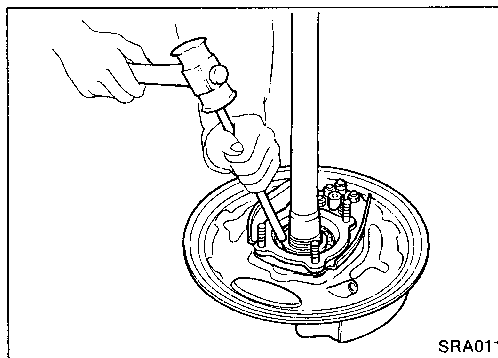

- Install plain washer and a new wheel bearing lock washer.
- Tighten wheel bearing lock nut.

**Fit wheel bearing lock washer lip in wheel bearing lock nut groove correctly by tightening lock nut. Be sure to bend it up.**

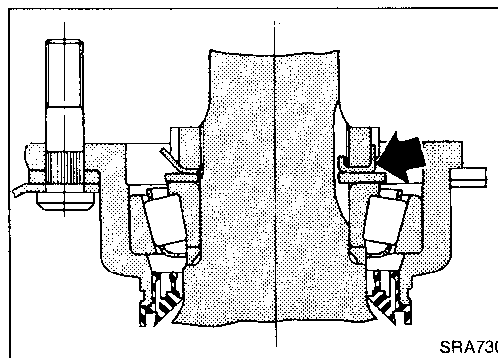

## REAR AXLE

### Drum Brake Type (Cont'd)

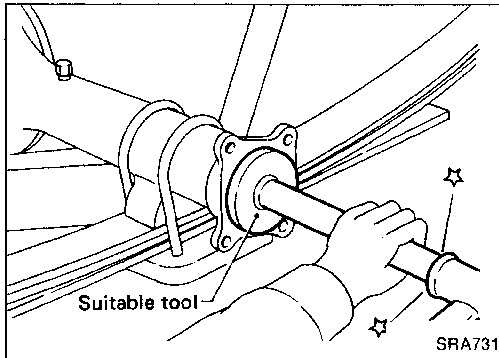

- Install a new oil seal with suitable tool.

After installing new oil seal, coat sealing lip with multi-purpose grease.

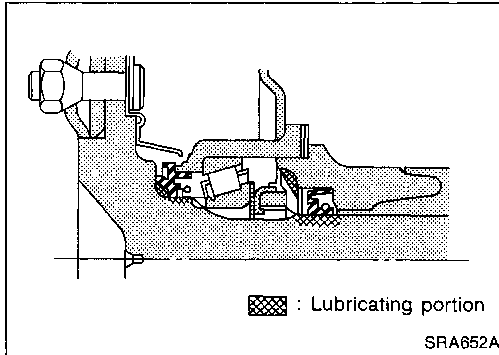

- Apply recess of axle case end with multi-purpose grease.
- Apply gear oil to the spline of axle shaft. Coat seal surface of axle shaft with multi-purpose grease (as shown left).

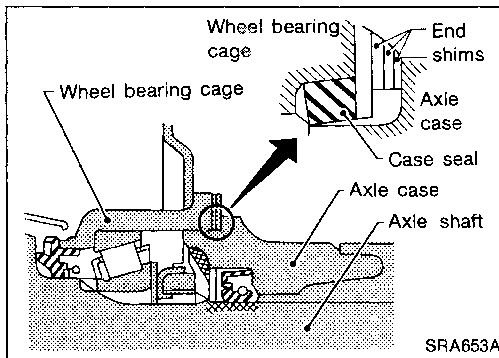

- Adjust axial end play.

- (1) Select end shims.

**Standard thickness: 1.5 mm (0.059 in)**

**Axle case end shim: Refer to SDS (RA-21).**

**Do not insert end shims between case seal and bearing cage.**

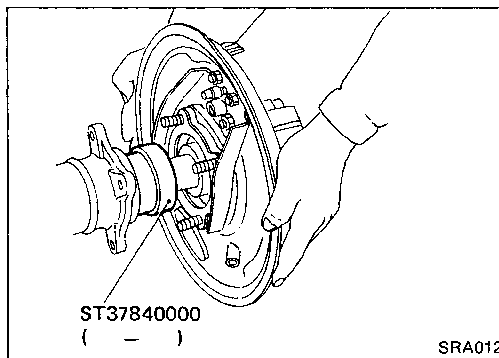

- (2) Insert axle shaft with Tool as a guide.

**When inserting axle shaft, be careful not to damage oil seal.**

- (3) Measure end play of axle shaft.

**Axial end play:**

**Servicing one side axle**

**0.02 - 0.15 mm (0.0008 - 0.0059 in)**

**Servicing both side axles**

**On first axle (right or left)**

**0.30 - 0.90 mm (0.0118 - 0.0354 in)**

**On second axle**

**0.02 - 0.15 mm (0.0008 - 0.0059 in)**

- (4) If axial end play is not within the specified limit, reselect axle case end shims.

**While adjusting axial end play, be careful not to damage oil seal.**

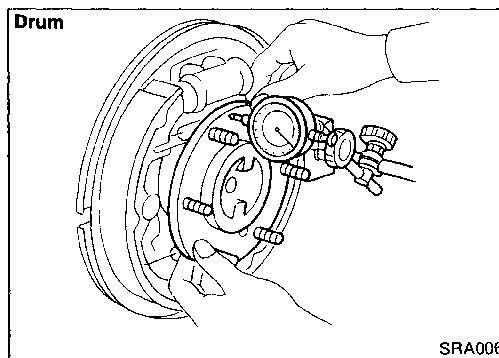



# REAR AXLE

## Disc Brake Type COMPONENTS

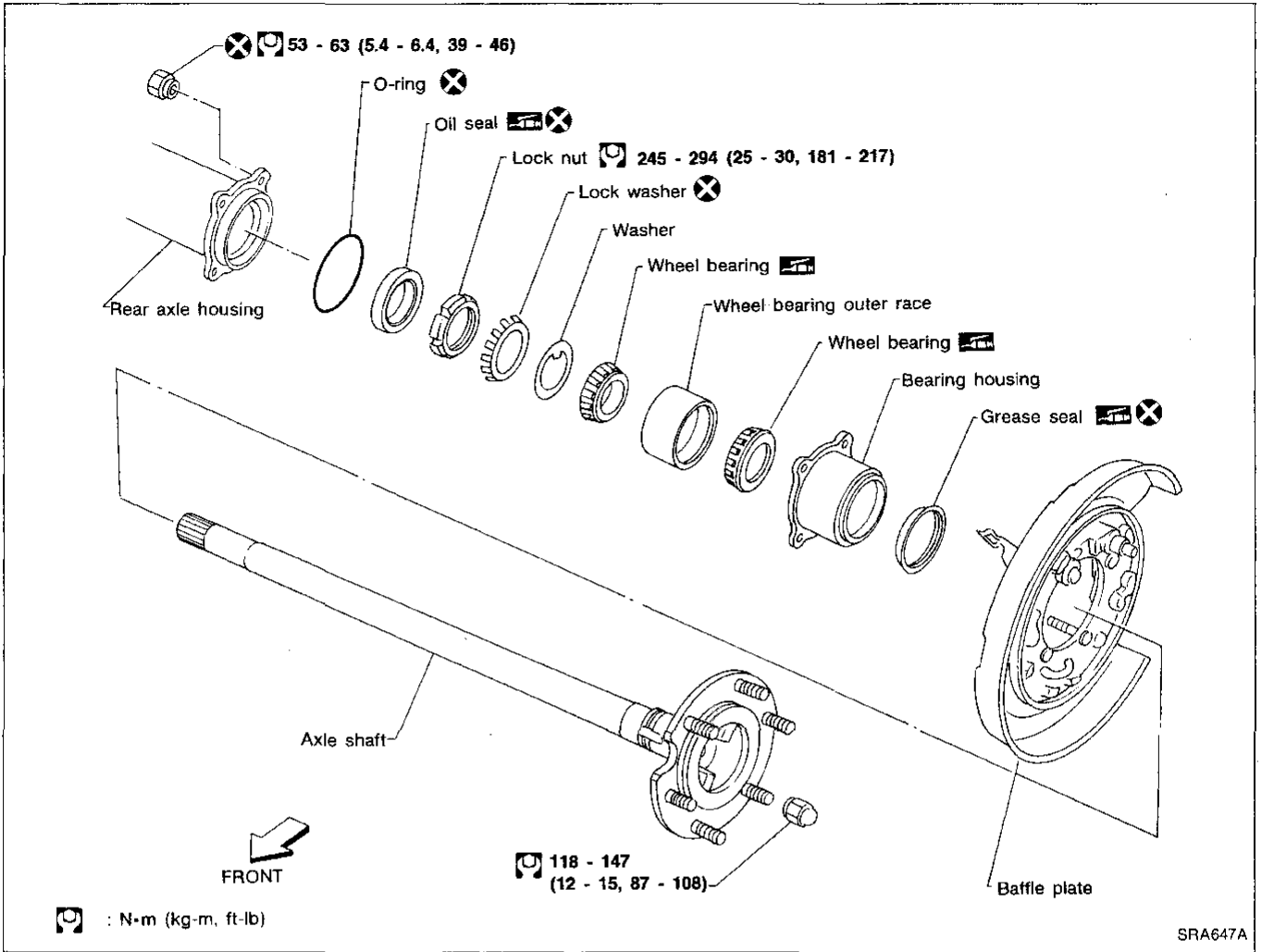

GF  
MA  
EM  
LC  
EF &  
EC  
FE  
CL  
MT  
AT  
TF  
PD

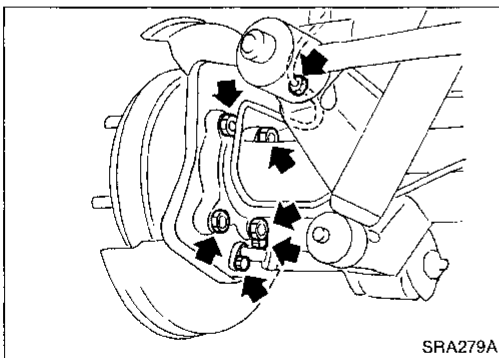

### REMOVAL

- Remove brake caliper assembly and rotor.
- Disconnect parking brake cable and brake tube.
- Remove nuts securing bearing housing to baffle plate.

FA  
RA

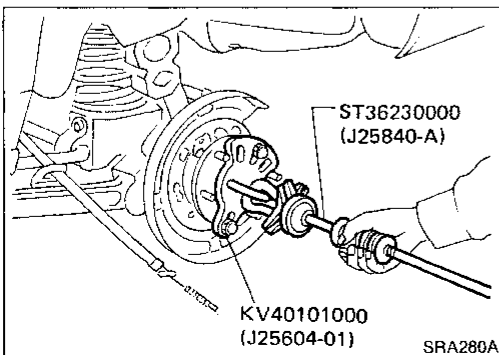

- Draw out axle shaft with Tool.
- When drawing out axle shaft, be careful not to damage oil seal.**

BR  
ST  
BF  
HA  
EL  
IDX

## REAR AXLE

### Disc Brake Type (Cont'd)

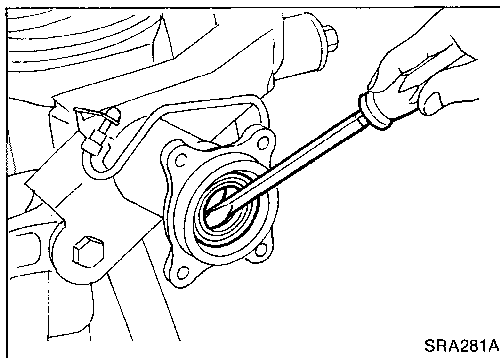

- Remove oil seal.  
**Do not reuse oil seal once it is removed.  
Always install new one.**

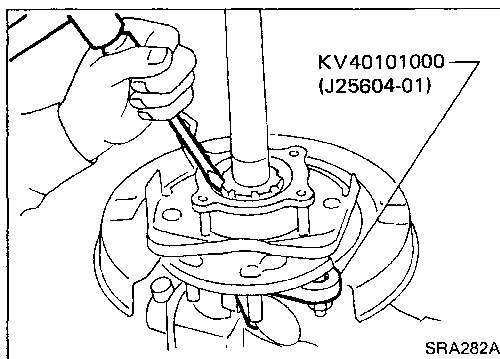

- Unbend lock washer with a screwdriver.  
**Do not reuse once removed lock washer.  
Always install new one.**

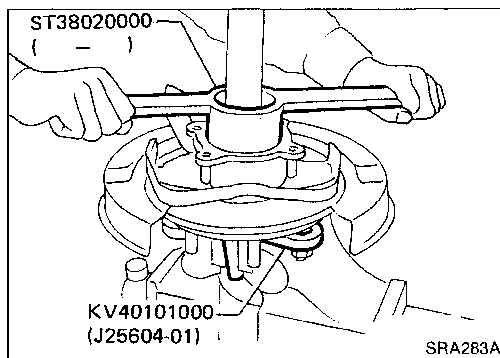

- Remove bearing lock nut with Tool.

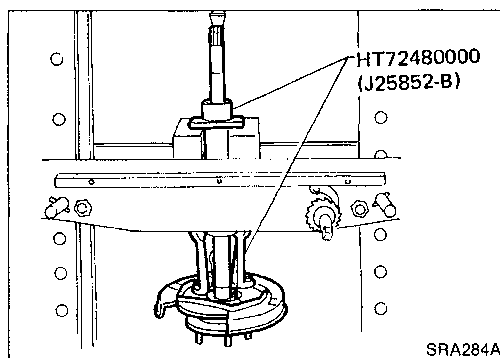

- Remove wheel bearing together with bearing housing and baffle plate from axle shaft.

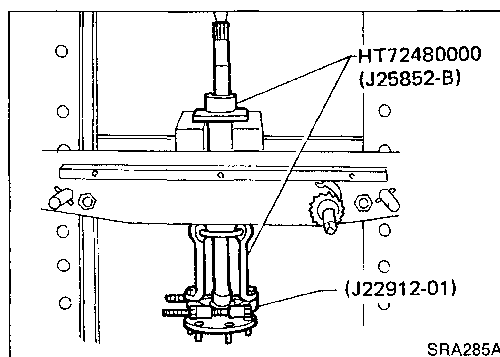

- Remove wheel bearing outer side inner race from axle shaft.

## REAR AXLE

### Disc Brake Type (Cont'd)

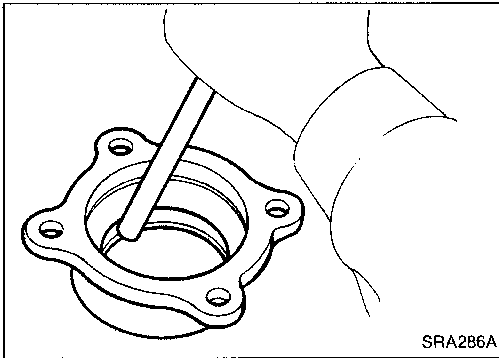

- Remove grease seal in bearing housing with suitable bar.

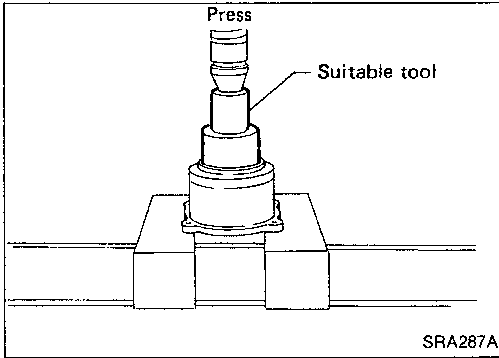

- Remove wheel bearing outer race with a suitable tool.

### INSPECTION

#### Axle shaft

Check axle shaft for straightness, cracks, damage, wear or distortion. Replace if necessary.

#### Bearing housing

Check bearing housing for deformation or cracks. Replace if necessary.

#### Rear axle housing

Check rear axle housing for yield, deformation or cracks. Replace if necessary.

### INSTALLATION

- Press new wheel bearing until it bottoms end face of bearing housing.

**Always press outer race of wheel bearing during installation.**

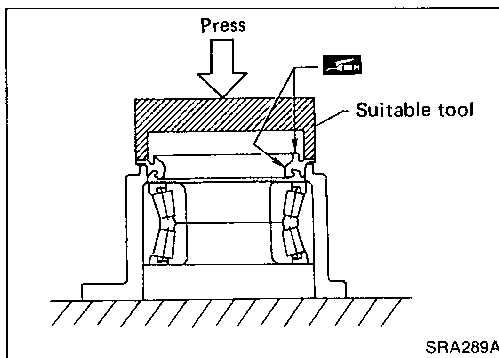
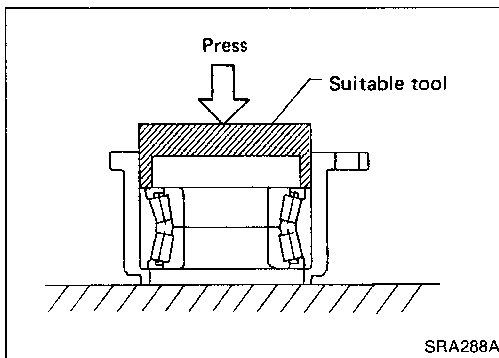

- Press new grease seal until it bottoms end face of bearing housing.

**After installing new grease seal, coat sealing lip with multi-purpose grease.**

## REAR AXLE

### Disc Brake Type (Cont'd)

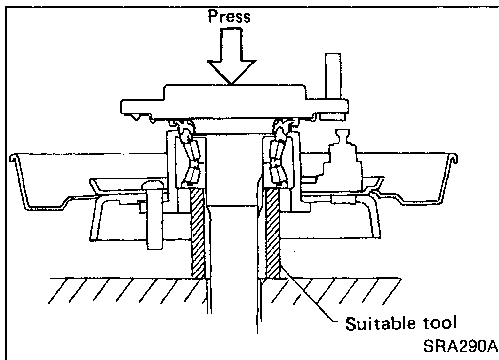

- Install baffle plate over bearing housing and press axle shaft into inner race of wheel bearing.

**Be careful not to damage or deform grease seal.**

- Before installing lock nut, apply a coat of wheel bearing grease to its seat. Tighten lock nut to specified torque.

: 245 - 294 N·m  
(25 - 30 kg-m, 181 - 217 ft-lb)

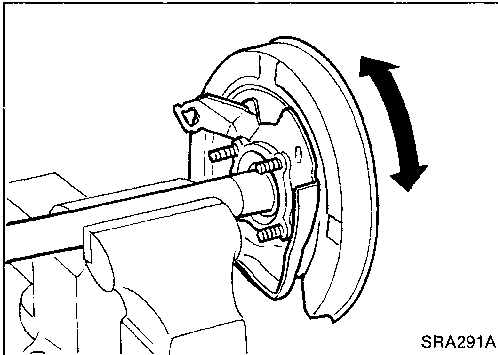

- Turn bearing housing (with respect to axle shaft) two or three times. It must turn smoothly.

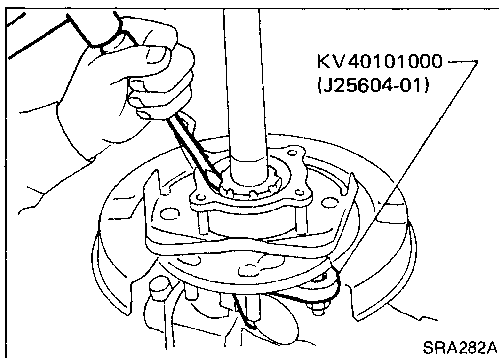

- Lock lock nut by bending one portion of lock washer.

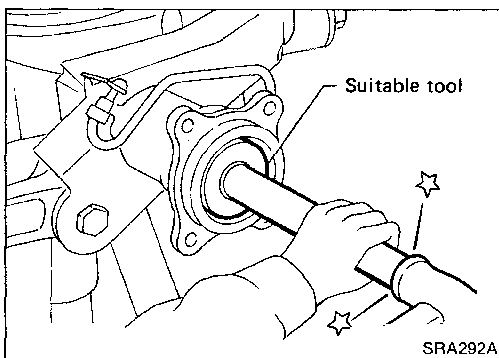

- Install new oil seal to rear axle housing using a suitable tool.

**After installing new oil seal, coat sealing lip with multi-purpose grease.**

- Position axle shafts in rear axle housing.

**Be careful not to damage oil seal.**

# REAR SUSPENSION

## 2WD TRUCK MODELS

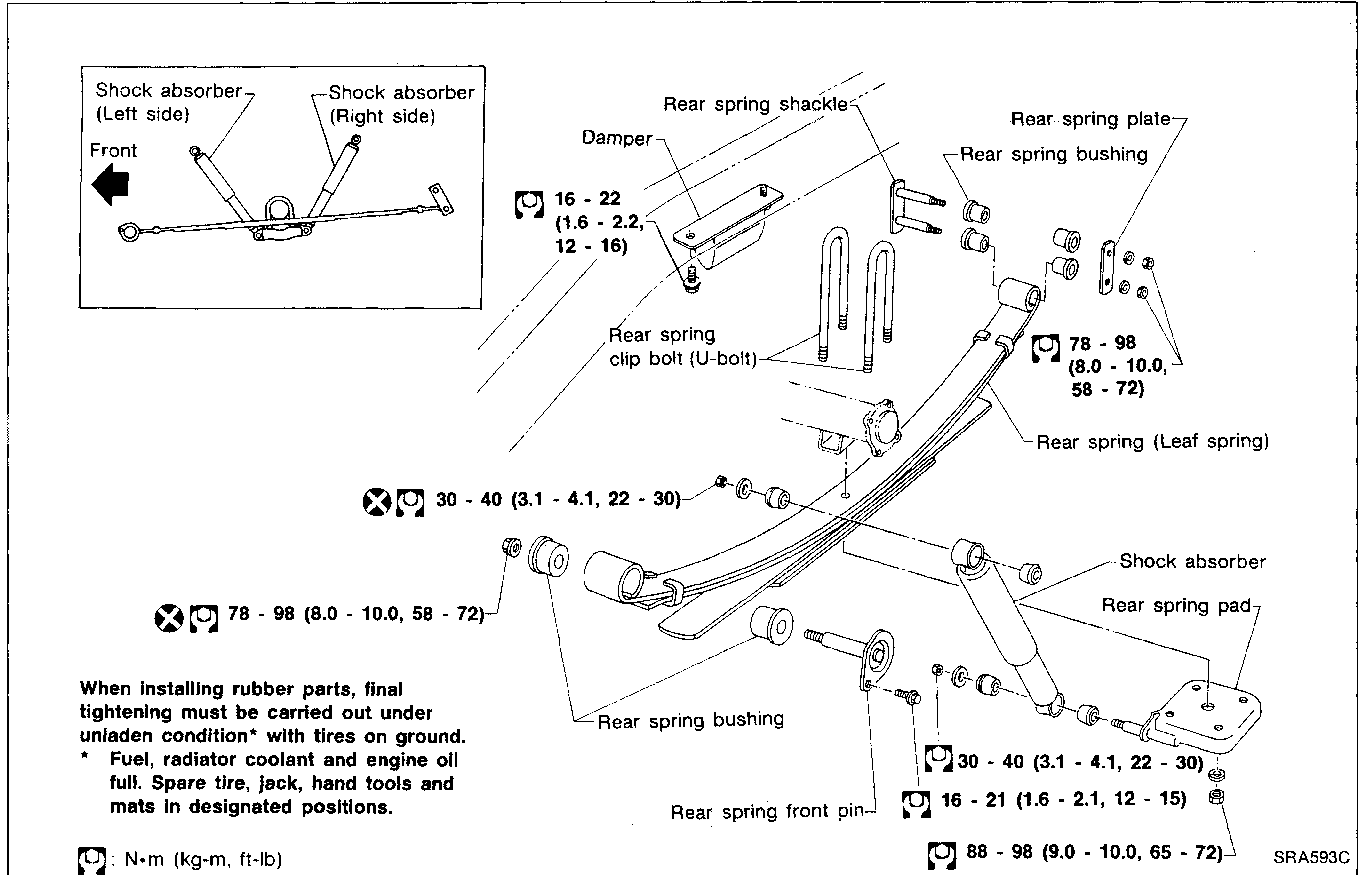

## 4WD TRUCK MODELS

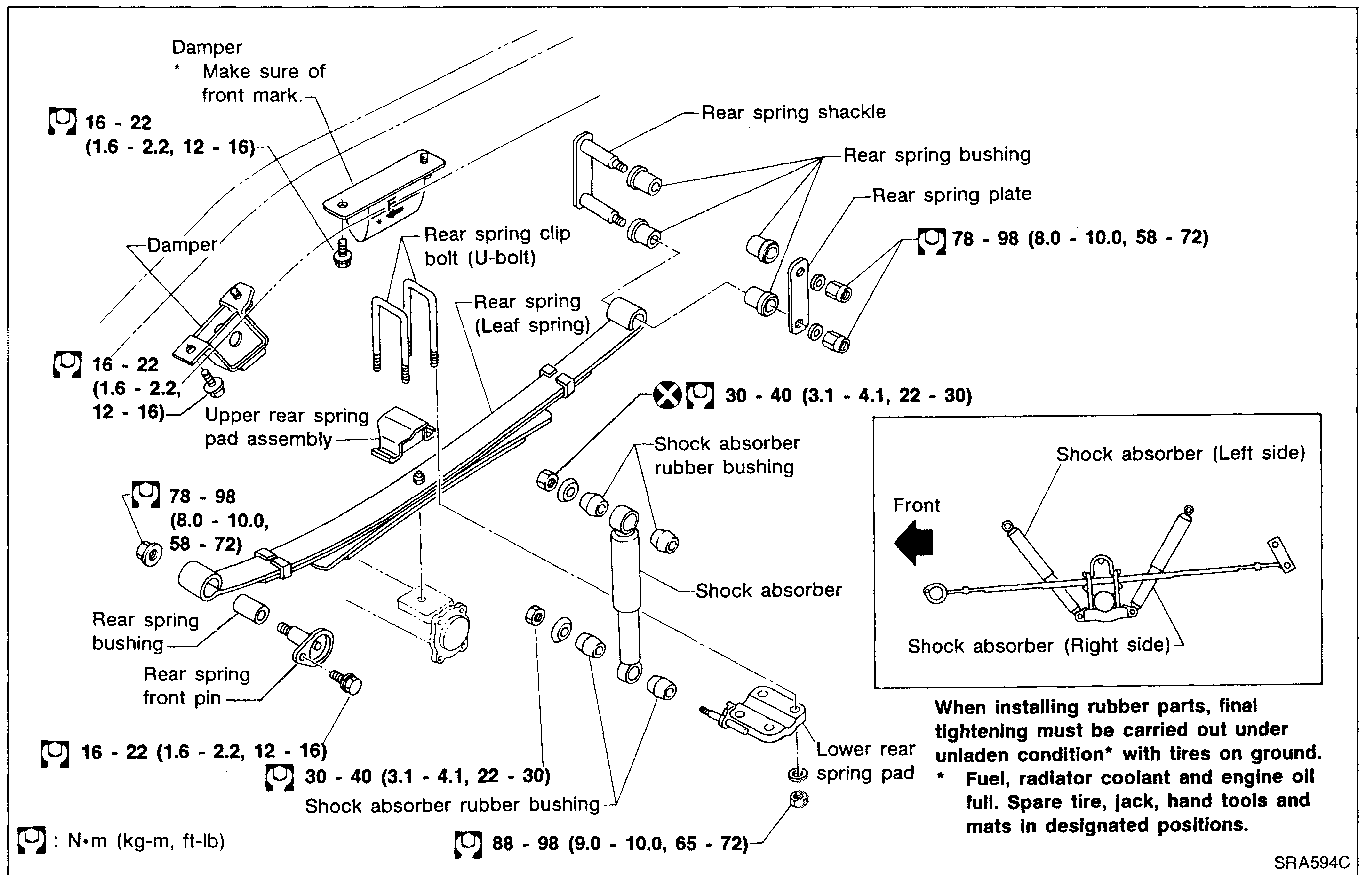

GE  
MA  
EM  
LC  
EF & EC  
FE  
CL  
MT  
AT  
TF  
PD  
FA  
RA  
BR  
ST  
BF  
HA  
EL  
IDX

## REAR SUSPENSION

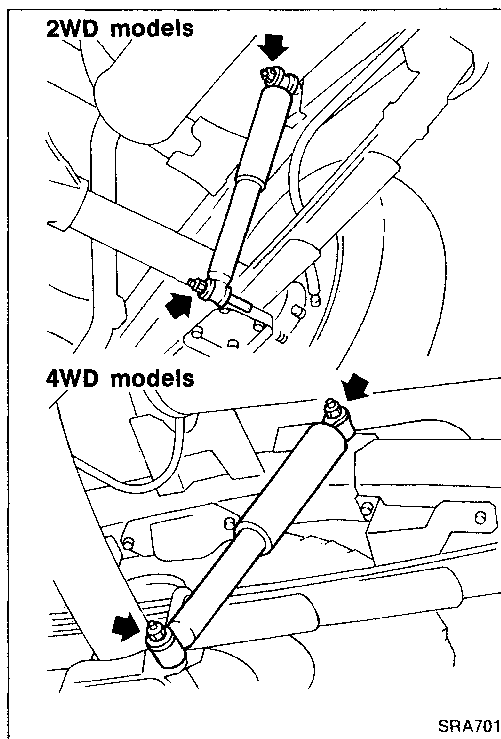

### Shock Absorber

#### REMOVAL AND INSTALLATION

- Remove shock absorber by disconnecting upper and lower end.

#### INSPECTION

- If oil leakage, cracks or deformation occurs, replace shock absorber assembly.
- If rubber bushings are cracked or deformed, replace rubber bushings.

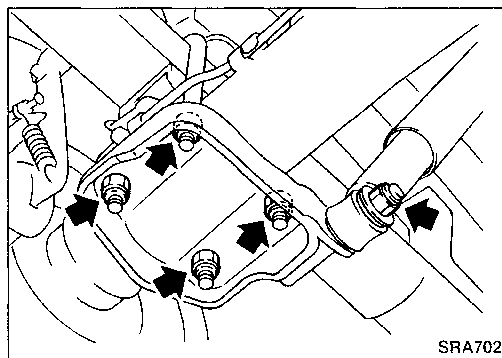

### Leaf Spring

#### REMOVAL AND INSTALLATION

- Disconnect shock absorber lower end, and remove U-bolts.

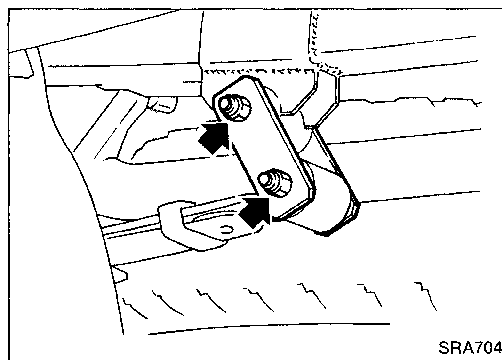

- Disconnect spring shackle.

## REAR SUSPENSION

### Leaf Spring (Cont'd)

- Disconnect front pin.

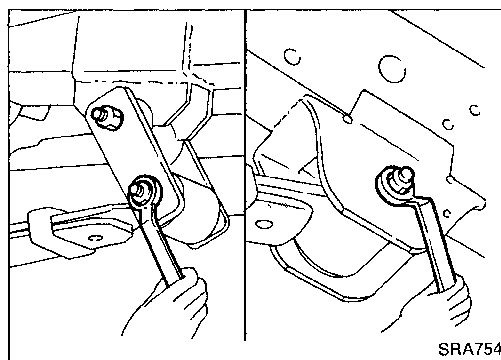
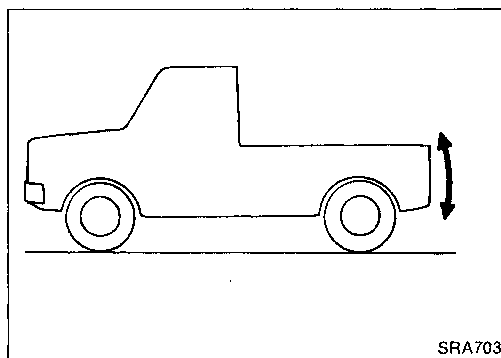
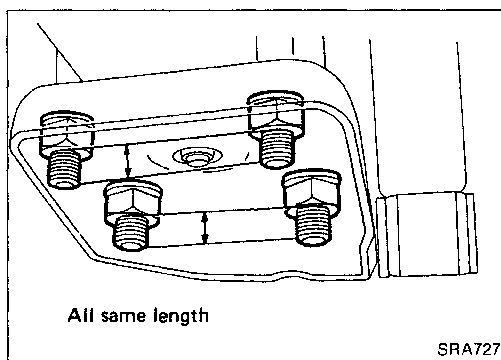
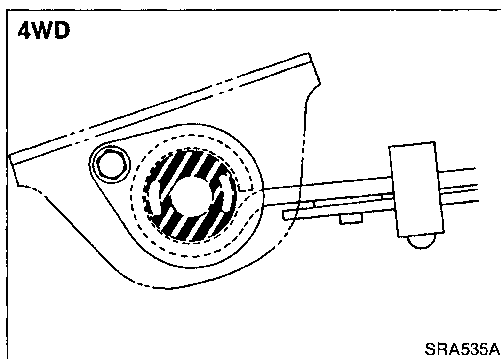
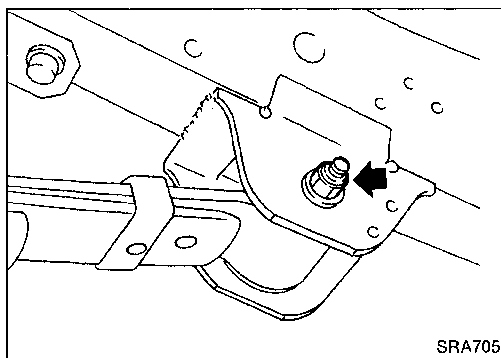

### INSPECTION

- Check leaf spring for cracks. Replace if necessary.
- Check front bracket and pin, shackle, U-bolts and spring pad for wear, cracks, straightness or damaged threads. Replace if necessary.
- Check all bushings for deformation or cracks. Replace if necessary.  
[4WD: Rear spring front bushing]  
Make sure that front bushing is properly installed.

### INSTALLATION

- Apply soapsuds to rubber bushing.
- Install spring shackle and front pin, and finger tighten the nuts.
- Install spring pad and nuts under leaf spring or axle case.
- Tighten U-bolt mounting nuts diagonally.

**Tighten U-bolts so that the lengths of all U-bolts under spring pad are the same.**

- Install shock absorber, and finger tighten the nuts.
- Remove stands and bounce the vehicle to stabilize suspension. (Unladen)

- Tighten spring shackle nuts, front pin nuts and shock absorber nuts.

**When installing rubber parts, final tightening must be carried out under unladen condition\* with tires on the ground.**

\* Fuel, radiator coolant and engine oil full. Spare tire, jack, hand tools and mats in designated positions.

GI

MA

EM

LC

EF &  
EC

FE

CL

MT

AT

TF

PD

FA

RA

BR

ST

BF

HA

EL

IDX

## REAR AXLE AND REAR SUSPENSION

### 5-link Type REMOVAL AND INSTALLATION

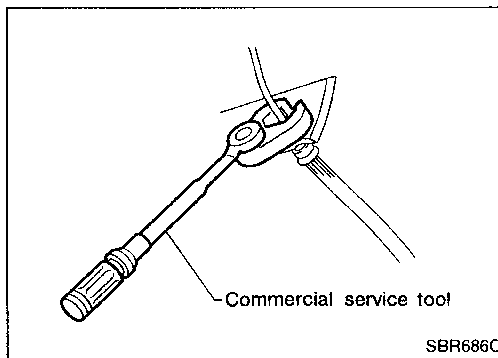
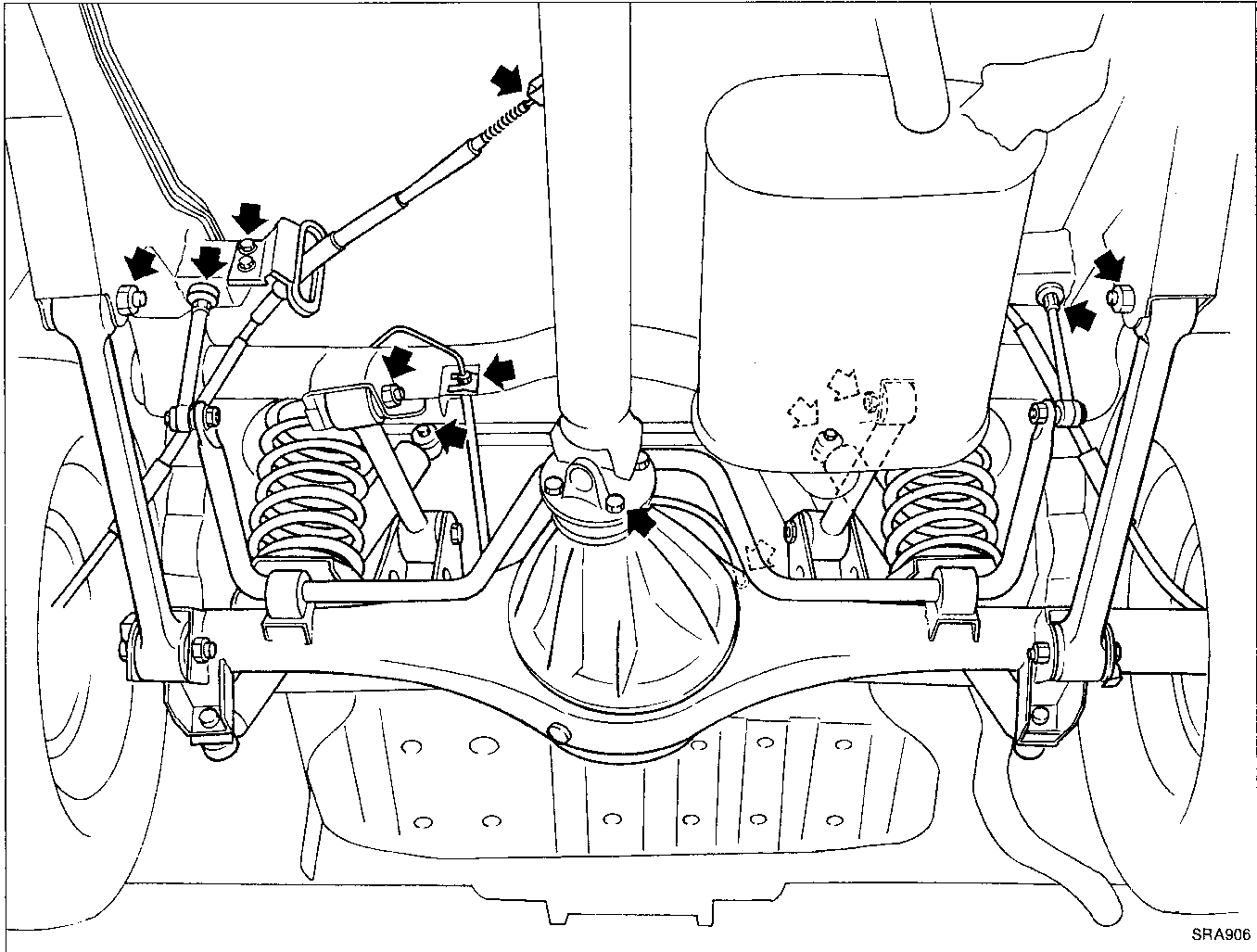

- Support axle and suspension components with a suitable jack and block.
- Disconnect brake hydraulic line and parking brake cables at back plates.

#### CAUTION:

**Use flare nut wrench when removing or installing brake tubes.**

- Remove stabilizer bar from body.
- Remove upper links and lower links from body.
- Remove panhard rod from body.
- Disconnect propeller shaft. Refer to PD section.
- Remove upper end nuts of shock absorber.

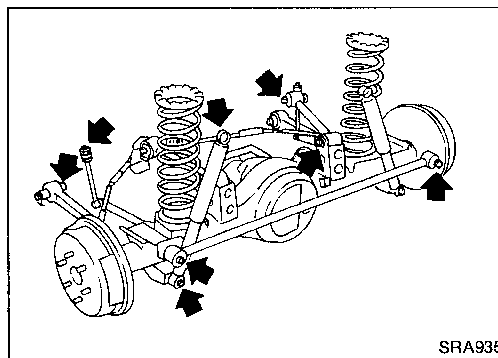

**Final tightening for rubber parts requires to be carried out under unladen condition with tires on ground.**



# REAR SUSPENSION

## 5-link Type

When installing rubber parts, final tightening must be carried out under unladen condition\* with tires on ground.

\* Fuel, radiator coolant and engine oil full.  
Spare tire, jack, hand tools and mats in designated positions.

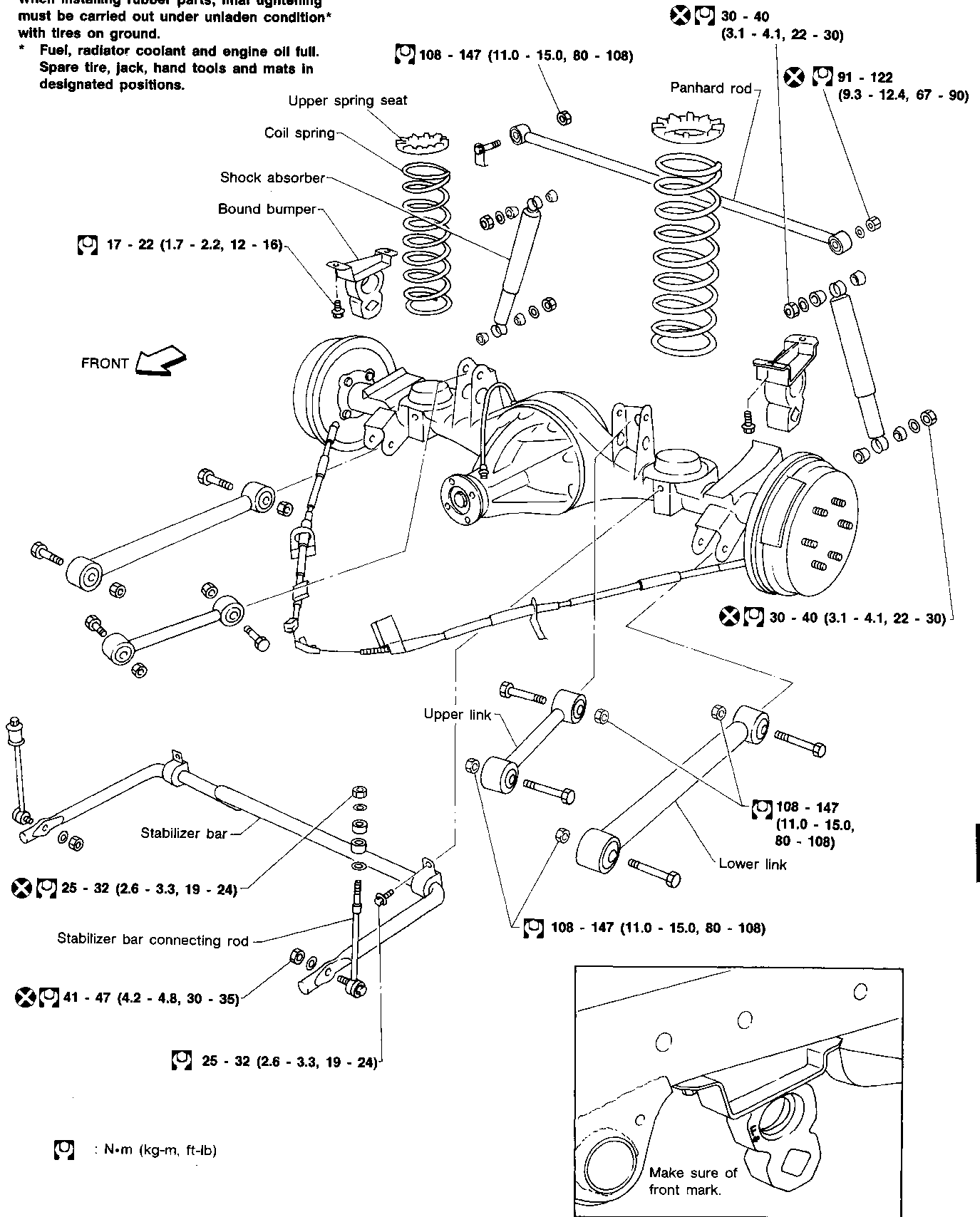

GE  
MA  
EM  
LC  
EF & EC  
FE  
CL  
MT  
AT  
TF  
PD  
FA  
RA  
BR  
ST  
BF  
HA  
EL

: N·m (kg-m, ft-lb)

## REAR SUSPENSION

### 5-link Type (Cont'd)

#### COIL SPRING AND SHOCK ABSORBER

##### Removal and Installation

- Refer to Removal and Installation of REAR AXLE AND REAR SUSPENSION - 5 link Type (RA-16).

**When installing coil spring, pay attention to its direction.**

**Be sure spring rubber seat is not twisted and has not slipped off when installing coil spring.**

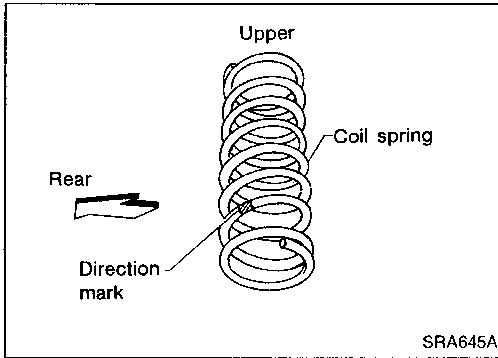

##### Inspection

- Check coil spring for yield, deformation or cracks.
- Check coil spring specifications. Refer to SDS (RA-21).
- Check shock absorber for oil leakage, cracks or deformation.
- Check shock absorber specifications. Refer to SDS (RA-21).
- Check all rubber parts for wear, cracks or deformation. Replace if necessary.

#### UPPER LINK, LOWER LINK AND PANHARD ROD

##### Inspection

Check for cracks, distortion or other damage. Replace if necessary.

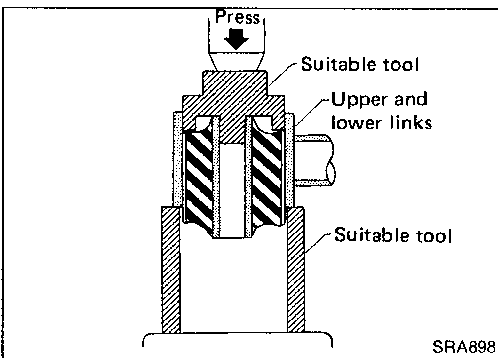

##### Bushing Replacement

Check for cracks or other damage. Replace with suitable tool if necessary.

- Remove bushing with suitable tool.

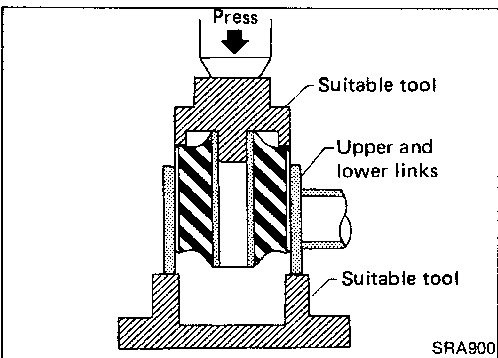

**When installing bushing, apply a coating of 1% soap water to outer wall of bushing.**

**Always install new bushing.**

**Do not tap end face of bushing directly with a hammer.**

# REAR SUSPENSION

## 5-link Type (Cont'd)

### Installation

When installing each link, pay attention to direction of bolts and nuts.

When installing each rubber part, final tightening must be carried out under unladen condition with tires on ground.

GI

MA

EM

LC

EF &  
EC

FE

CL

MT

AT

TF

PD

FA

**RA**

BR

ST

BF

HA

EL

IDX

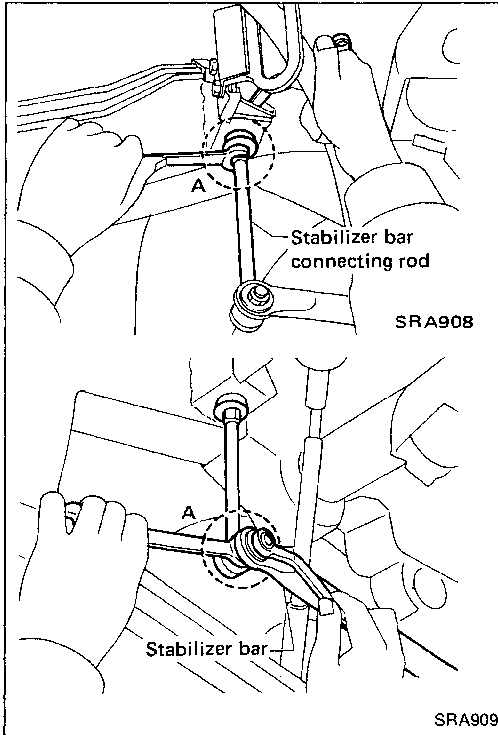

### STABILIZER BAR

#### Removal and Installation

- When removing and installing stabilizer bar, fix portion A.

# SERVICE DATA AND SPECIFICATIONS (SDS)

## General Specifications

### LEAF SPRING AND SHOCK ABSORBER (Trucks)

Applied model	2WD			4WD
	Except Heavy duty		Heavy duty	
	U.S.A.	Canada		
Leaf spring				
Spring length x width	mm (in)	1,200 x 60 (47.24 x 2.36)		
Spring thickness - number of leaves	mm (in)	7 (0.28) - 2 13 (0.51) - 1	7 (0.28) - 2 12 (0.47) - 2	8 (0.31) - 2 14 (0.55) - 2
Free camber "S"	mm (in)	174.9 (6.89)	169.1 (6.66)	138.7 (5.46)
Shock absorber				
Shock absorber type	Non-adjustable			
Maximum length	mm (in)	508 (20.00)		528 (20.79)
Compression	N (kg, lb)	157 - 275 (16 - 28, 35 - 62)		265 - 422 (27 - 43, 60 - 95)

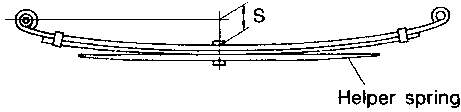

Helper spring

SRA657A

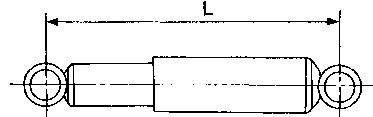

SRA658A

# SERVICE DATA AND SPECIFICATIONS (SDS)

## General Specifications (Cont'd)

### COIL SPRING AND SHOCK ABSORBER (Pathfinder)

Coil spring		
Wire diameter mm (in)	13.2 (0.520)	
Coil diameter mm (in)	117.2 (4.61)	
Free length mm (in)	417.0 (16.42)	
Identification color	White x 1, Blue x 1	
Shock absorber		
Shock absorber type	Non-adjustable	Adjustable
Maximum length mm (in)	586 (23.07)	585 (23.03)

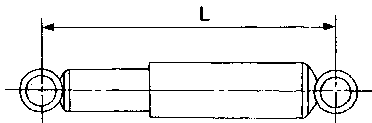

SRA658A

### STABILIZER BAR (Pathfinder)

Stabilizer bar diameter mm (in)	25.0 (0.984)
---------------------------------	--------------

## Inspection and Adjustment

### WHEEL BEARING (Drum brake models)

Total end play mm (in)	0.02 - 0.15 (0.0008 - 0.0059)	
Available rear axle case end shims	Thickness mm (in)	Part number
	0.05 (0.0020)	43086-P0110
	0.07 (0.0028)	43087-P0110
	0.10 (0.0039)	43088-P0110
	0.15 (0.0059)	43086-B9500
	0.20 (0.0079)	43089-P0110
	0.50 (0.0197)	43090-P0110
1.00 (0.0394)	43036-01G00	

### WHEEL BEARING (Disc brake models)

Total end play mm (in)	0 (0)
Bearing preload measured at bearing cage under load of 32,363 N (3,300 kg, 7,277 lb) N (kg, lb)	6.9 - 48.1 (0.7 - 4.9, 1.5 - 10.8)

GI

MA

EM

LC

EF &  
EC

FE

CL

MT

AT

TF

PD

FA

**RA**

BR

ST

BF

HA

EL

IDX