

CLUTCH

SECTION **CL**

GI

MA

EM

LC

EF &
EC

FE

CL

MT

AT

TF

PD

FA

RA

BR

ST

BF

HA

EL

IDX

CONTENTS

PRECAUTIONS AND PREPARATION	2	Operating Cylinder.....	8
Precautions.....	2	Clutch Damper.....	9
Special Service Tools.....	2	CLUTCH RELEASE MECHANISM	10
Commercial Service Tools.....	2	CLUTCH DISC AND CLUTCH COVER	12
CLUTCH SYSTEM	3	Clutch Disc.....	12
Clutch Pedal.....	4	Clutch Cover and Flywheel.....	13
INSPECTION AND ADJUSTMENT	5	SERVICE DATA AND SPECIFICATIONS (SDS)	14
Adjusting Clutch Pedal.....	5	General Specifications.....	14
Bleeding Procedure.....	6	Inspection and Adjustment.....	14
HYDRAULIC CLUTCH CONTROL	7		
Clutch Master Cylinder.....	7		

PRECAUTIONS AND PREPARATION

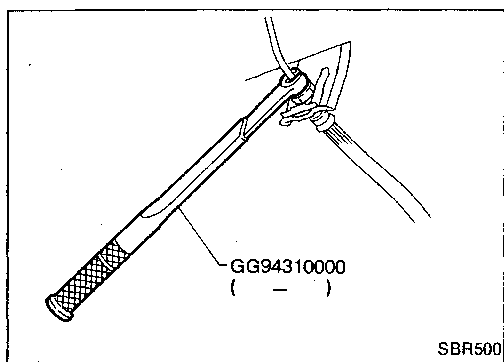

Precautions

- Recommended fluid is brake fluid "DOT 3".
- Never reuse drained brake fluid.
- Be careful not to splash brake fluid on painted areas.
- When removing and installing clutch piping, use Tool.
- To clean or wash all parts of master cylinder, operating cylinder and clutch damper, use clean brake fluid.
- Never use mineral oils such as gasoline or kerosene. They will ruin the rubber parts of the hydraulic system.

WARNING:

Remove all dust from clutch disc with a dust collector after cleaning with waste cloth.

Special Service Tools

Tool number (Kent-Moore No.) Tool name	Description	
ST20050010 (-) Base plate ST20050100 (-) Distance piece	 NT058	Inspecting diaphragm spring of clutch cover
GG94310000 (-) Flare nut torque wrench	 NT064	Removing and installing each clutch piping
ST20600000 (J26366) Clutch aligning bar	 NT062	Installing clutch cover and clutch disc
ST20050240 (-) Diaphragm spring adjusting wrench	 NT060	Adjusting unevenness of diaphragm spring of clutch cover

Commercial Service Tools

Tool name	Description	
Bearing puller	 NT077	Removing release bearing
Bearing drift	 NT063	Installing release bearing a = 50 mm (1.97 in) dia.

CLUTCH SYSTEM

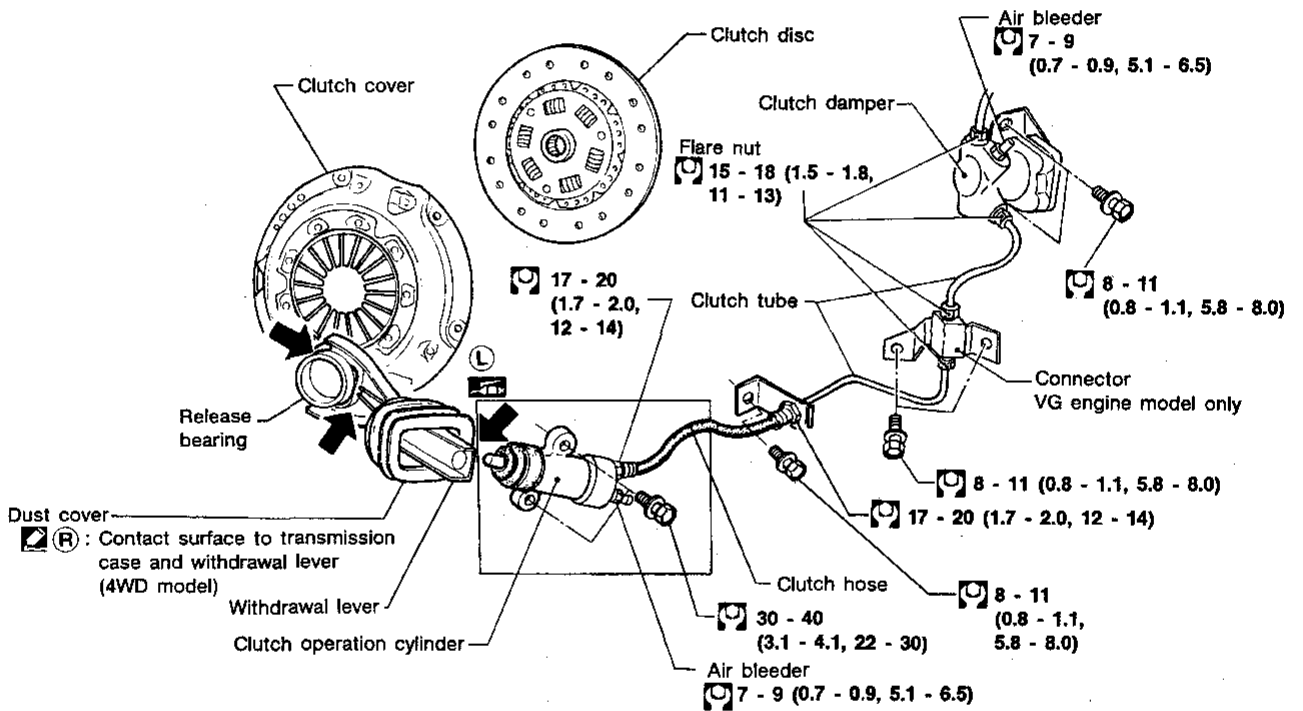
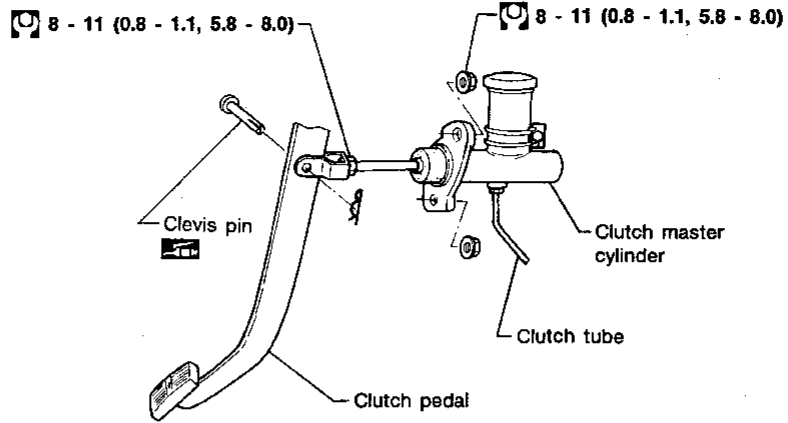

(R) : Contact surface to transmission case and withdrawal lever (4WD model)
 (L) : Apply lithium-based grease including molybdenum disulphide.
 : N·m (kg-m, ft-lb)

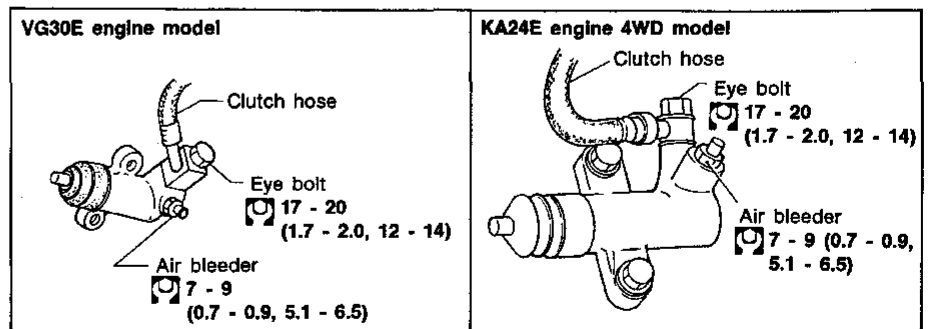

(R) : Apply recommended sealant (Nissan genuine part: KP115-00100) or equivalent.
 (L) : Apply lithium-based grease including molybdenum disulphide.
 : N·m (kg-m, ft-lb)

CLUTCH SYSTEM

Clutch Pedal

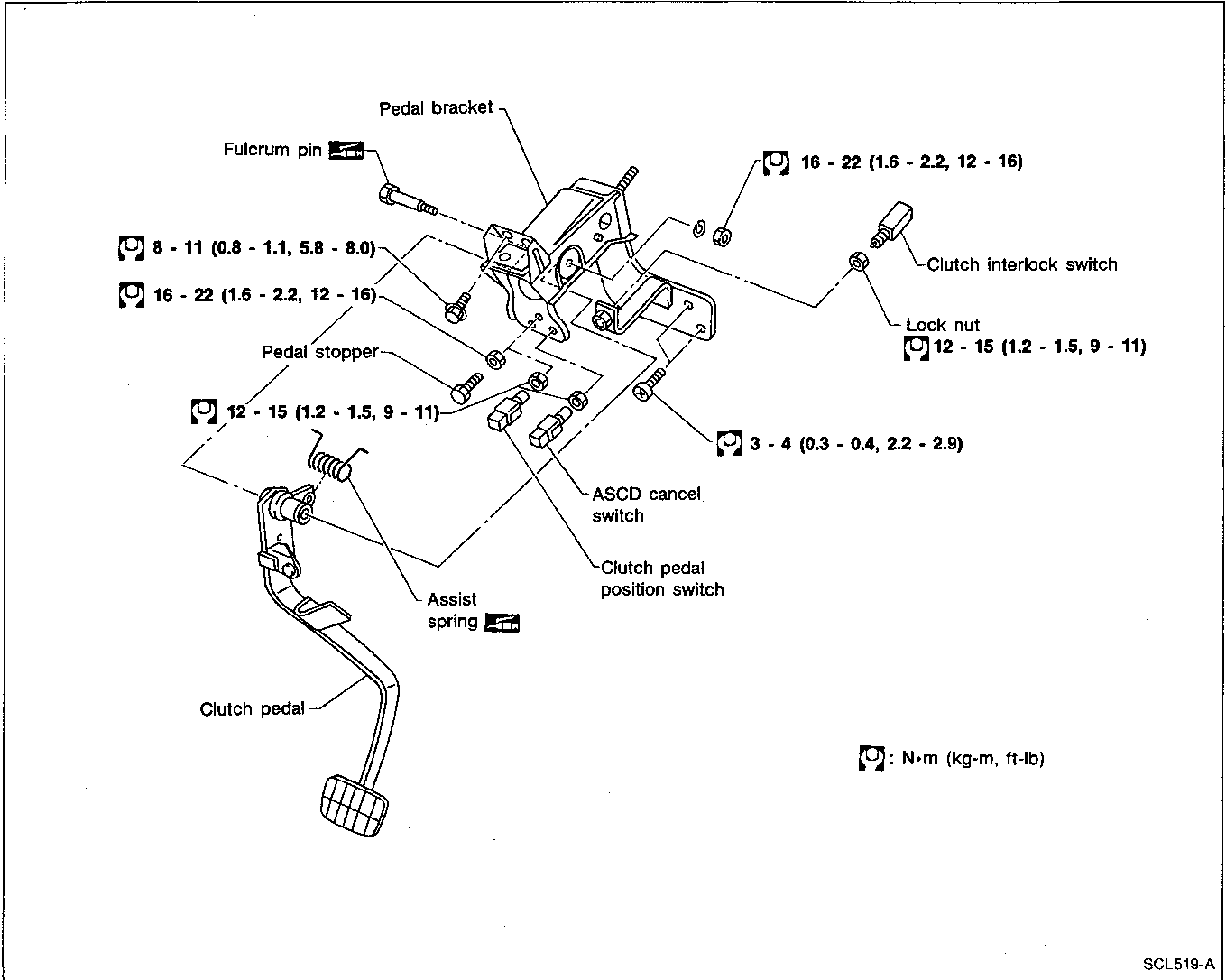

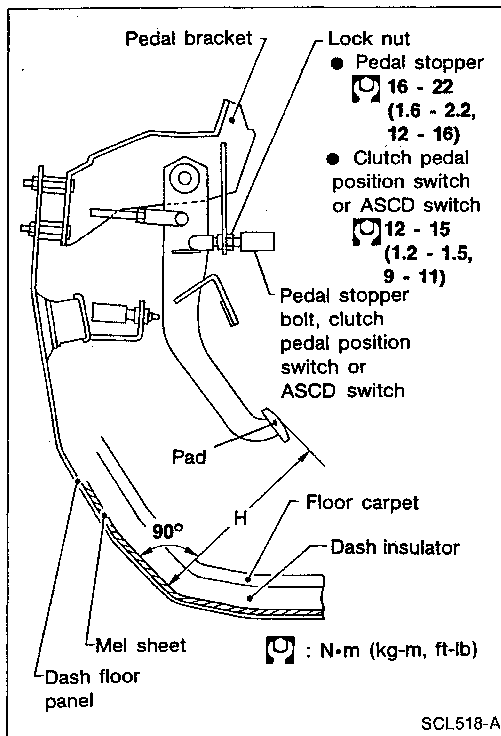

Adjusting Clutch Pedal

1. Adjust pedal height with pedal stopper or clutch pedal position switch.

Pedal height "H":

KA24E engine	236 - 246 mm (9.29 - 9.69 in)
VG30E engine	227 - 237 mm (8.94 - 9.33 in)

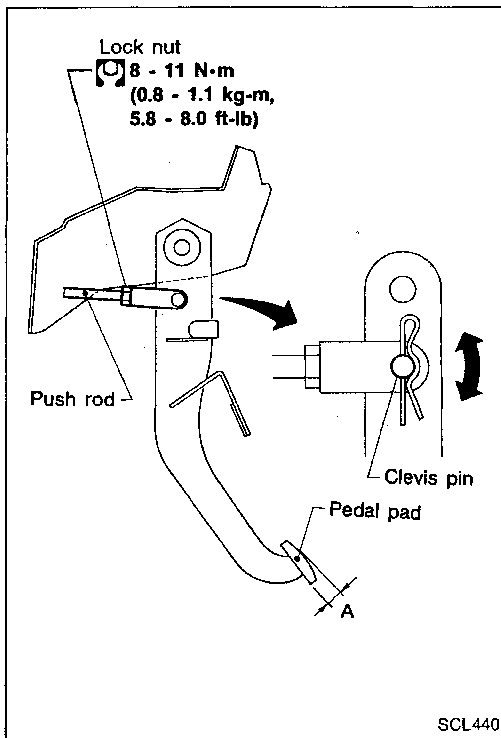

2. Adjust pedal free play with master cylinder push rod. Then tighten lock nut.

Pedal free play "A":

1.0 - 1.5 mm (0.039 - 0.059 in)

Pedal free play means the following total measured at position of pedal pad:

- **Play due to clevis pin and clevis pin hole in clutch pedal.**
3. Make sure that clevis pin can rotate smoothly. If not, readjust pedal free play with master cylinder push rod.

GI

MA

EM

LC

EF &
EC

FE

CL

MT

AT

TF

PD

FA

RA

BR

ST

BF

HA

EL

IDX

INSPECTION AND ADJUSTMENT

Adjusting Clutch Pedal (Cont'd)

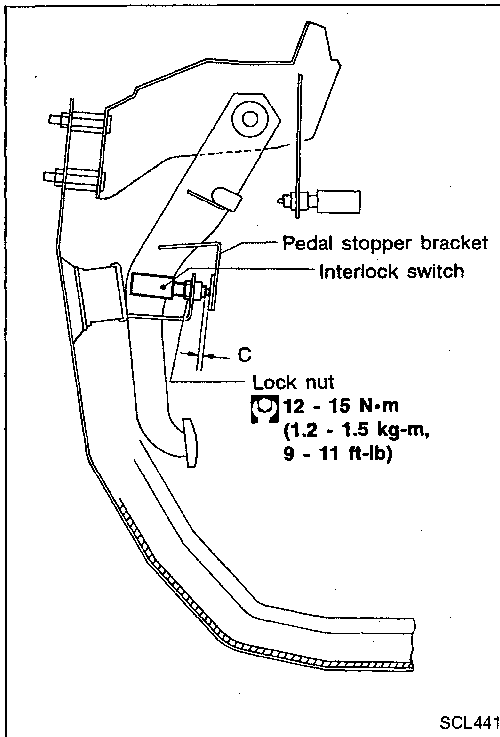

- Adjust clearance "C" between pedal stopper bracket and threaded end of clutch interlock switch while depressing clutch pedal fully.

Clearance "C":

0.3 - 1.0 mm (0.012 - 0.039 in)

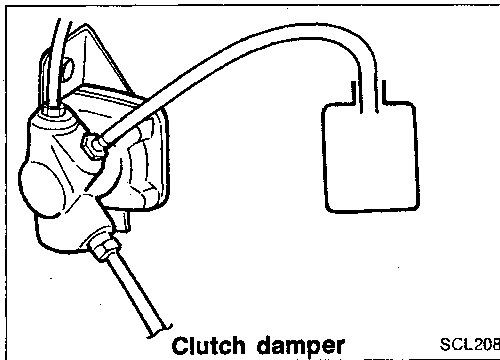

Bleeding Procedure

- Bleed air from clutch operating cylinder according to the following procedure.
 - **Carefully monitor fluid level at master cylinder during bleeding operation.**
 - Top up reservoir with recommended brake fluid.
 - Connect a transparent vinyl tube to air bleeder valve.
 - Fully depress clutch pedal several times.
 - With clutch pedal depressed, open bleeder valve to release air.
 - Close bleeder valve.
 - Repeat steps c through e above until brake fluid flows from air bleeder valve without air bubbles.
- Bleed air from clutch damper according to the above procedure.
- Repeat the above bleeding procedure 1 and 2 several times.

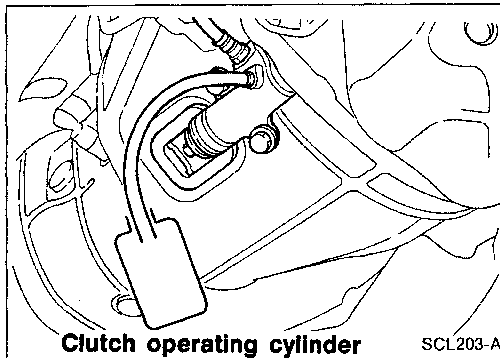

HYDRAULIC CLUTCH CONTROL

Clutch Master Cylinder

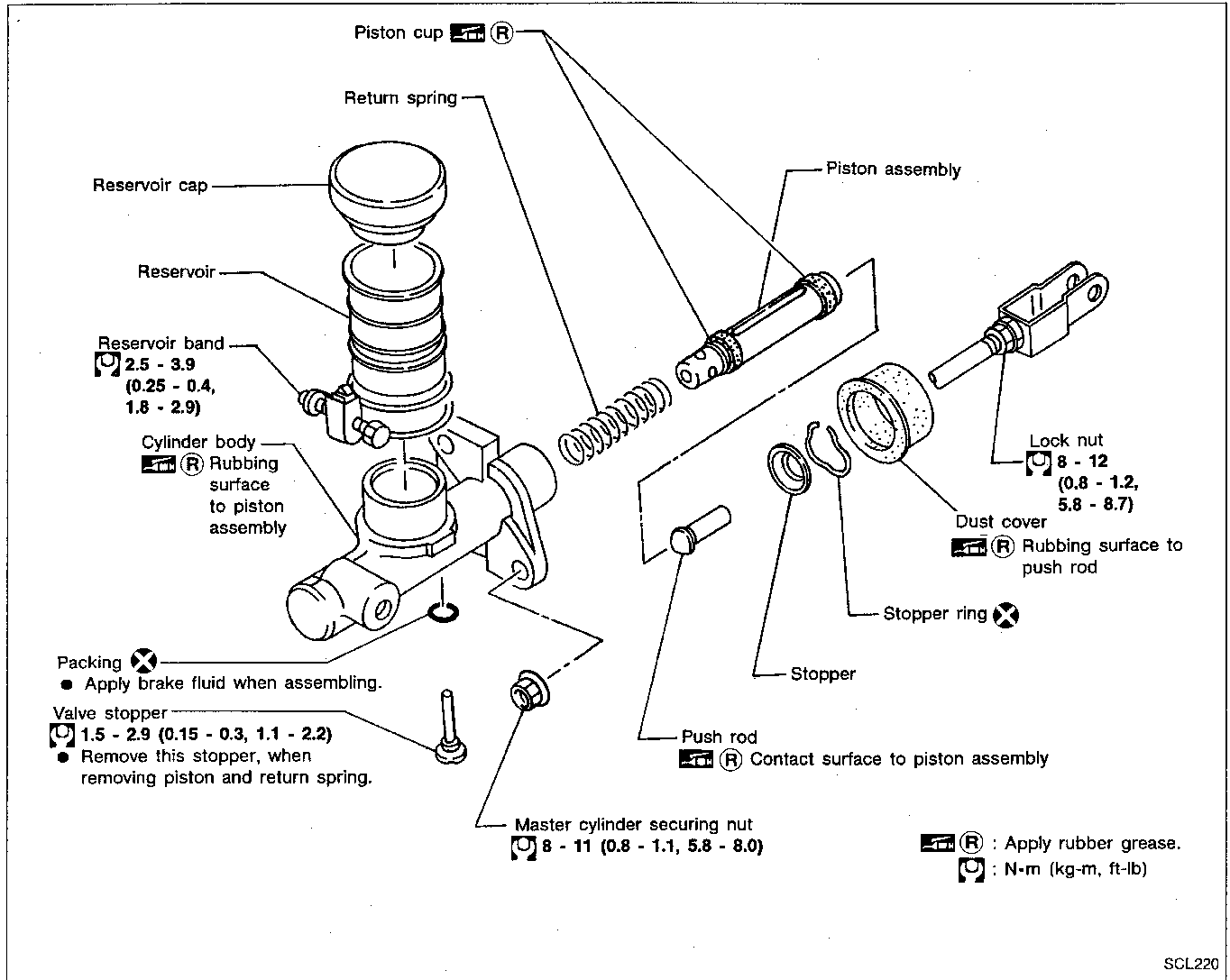

DISASSEMBLY AND ASSEMBLY

- Push piston in cylinder body with screwdriver when removing and installing valve stopper.

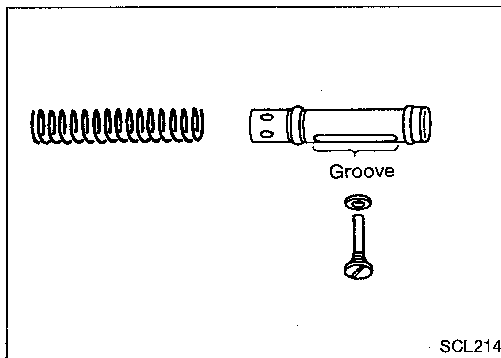

- Align groove of piston assembly and valve stopper portion when installing valve stopper.
- Check direction of piston caps.

HYDRAULIC CLUTCH CONTROL

Clutch Master Cylinder (Cont'd)

- Check cylinder and piston rubbing surface for uneven wear, rust or damage. Replace if necessary.
- Check piston with piston cup for wear or damage. Replace if necessary.
- Check return spring for wear or damage. Replace if necessary.
- Check reservoir for deformation or damage. Replace if necessary.
- Check dust cover for cracks, deformation or damage. Replace if necessary.

Operating Cylinder

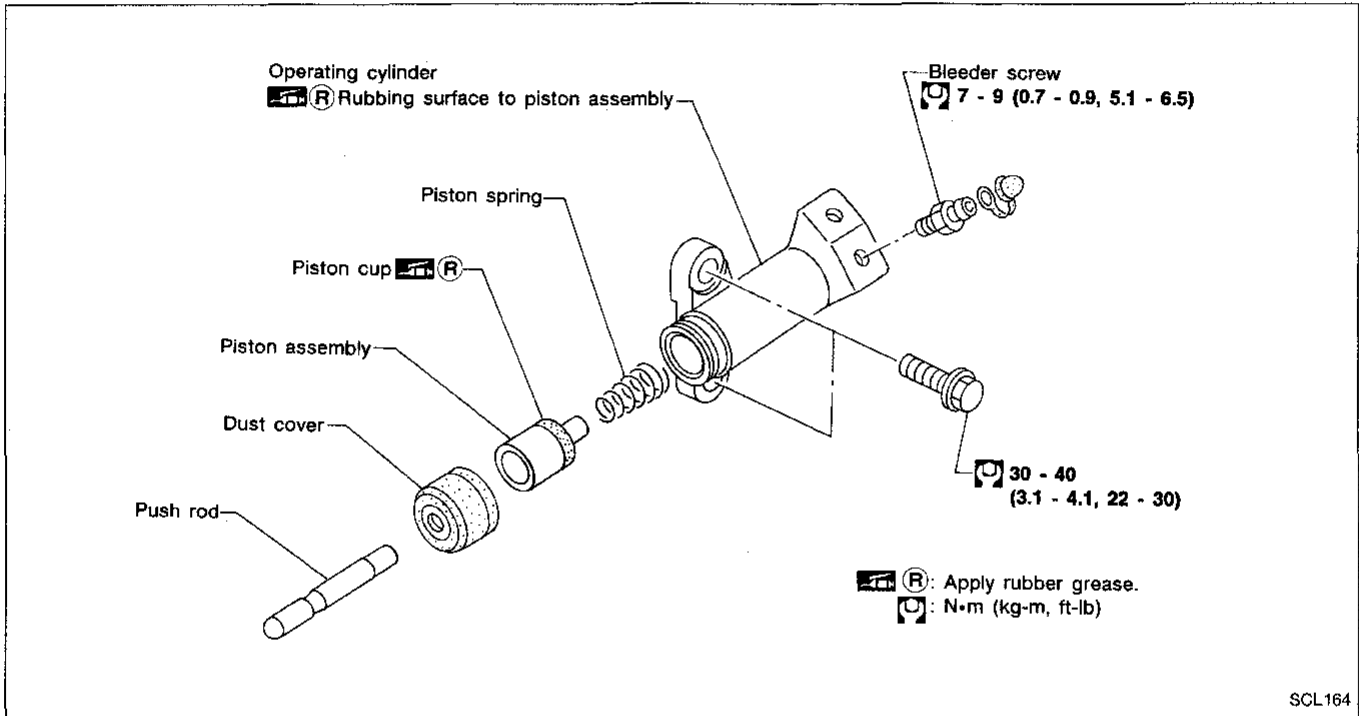

INSPECTION

- Check rubbing surface of cylinder for wear, rust or damage. Replace if necessary.
- Check piston with piston cup for wear or damage. Replace if necessary.
- Check piston spring for wear or damage. Replace if necessary.
- Check dust cover for cracks, deformation or damage. Replace if necessary.

Clutch Damper

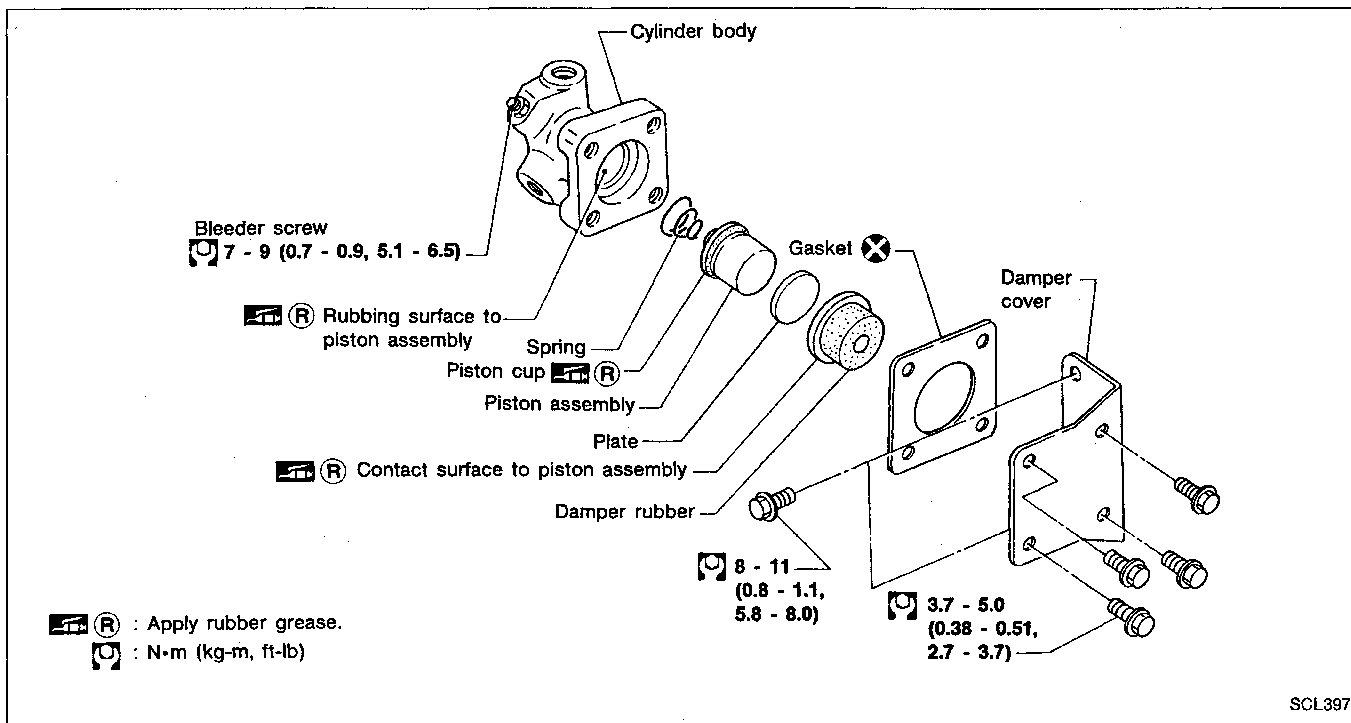

INSPECTION

- Check cylinder and piston rubbing surface for uneven wear, rust or damage. Replace if necessary.
- Check damper rubber and piston cup for cracks, deformation or damage. Replace if necessary.

GI

MA

EM

LC

EF &
EC

FE

CL

MT

AT

TF

PD

FA

RA

BR

ST

BF

HA

EL

IDX

CLUTCH RELEASE MECHANISM

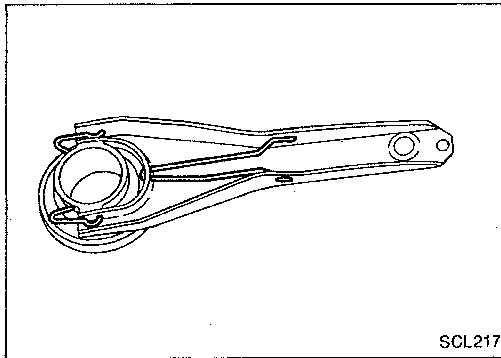
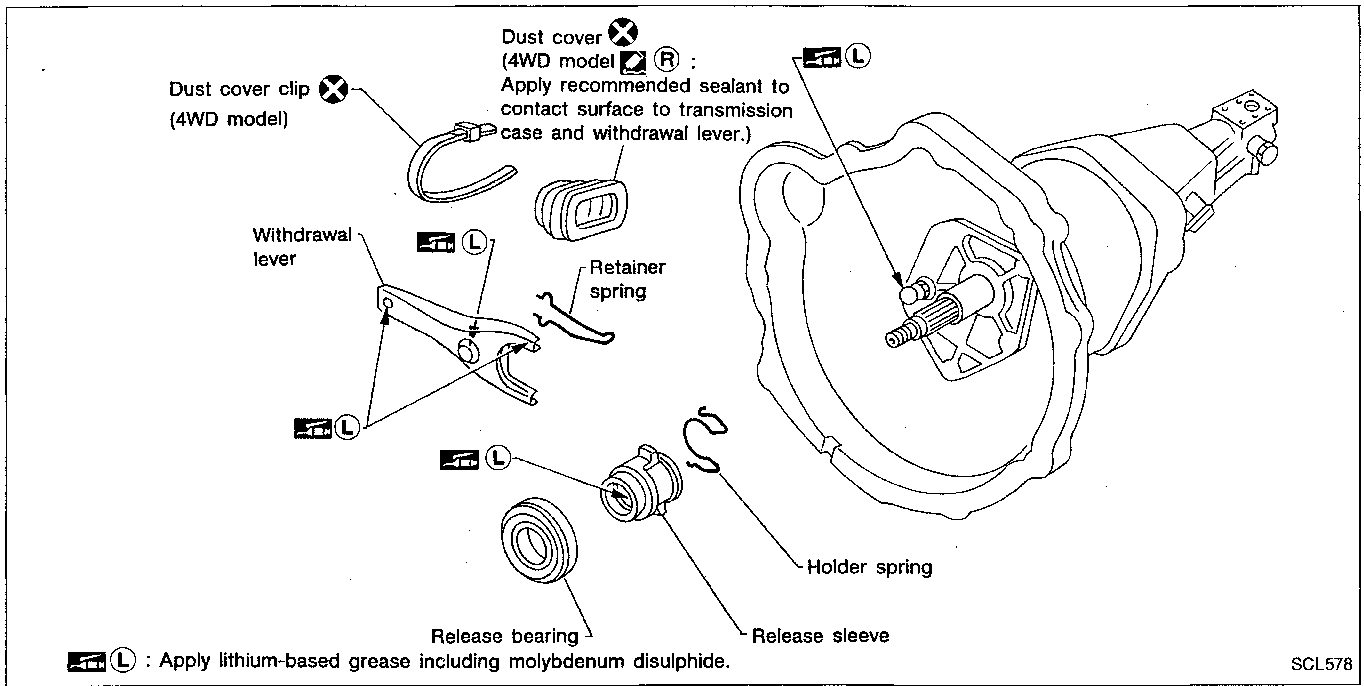

REMOVAL AND INSTALLATION

- Install retainer spring and holder spring.

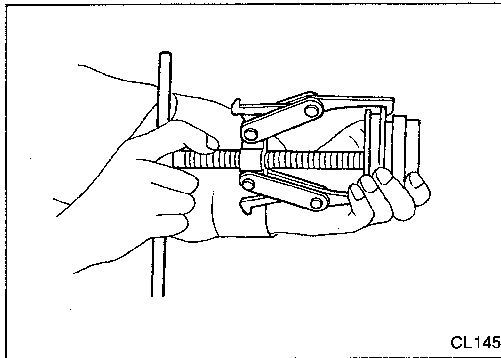

- Remove release bearing.

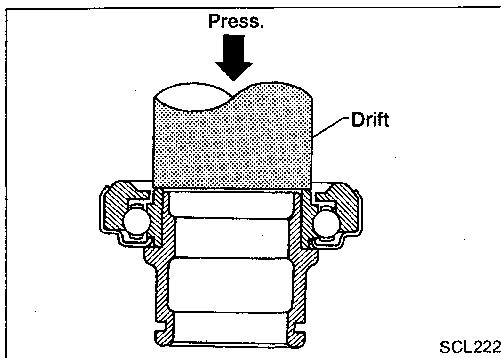

- Install release bearing with suitable drift.

CLUTCH RELEASE MECHANISM

INSPECTION

- Check release bearing to see that it rolls freely and is free from noise, crack, pitting or wear. Replace if necessary.
- Check release sleeve and withdrawal lever rubbing surface for wear, rust or damage. Replace if necessary.

GI

MA

EM

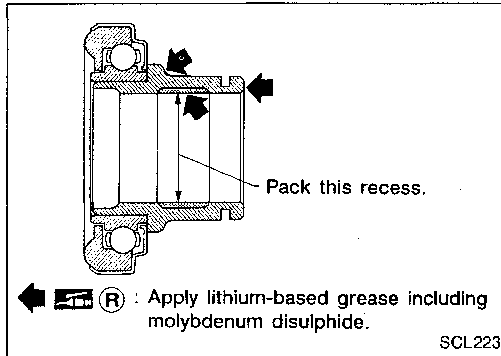

LUBRICATION

- Apply recommended grease to contact surface and rubbing surface.
- **Too much lubricant might damage clutch disc facing damage.**

LC

EF &
EC

FE

CL

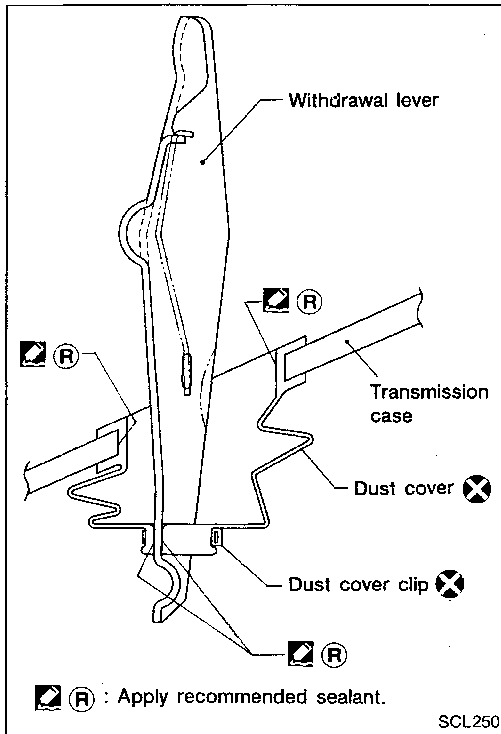

WATERPROOF — for 4WD model

- Apply recommended sealant to contact surface of dust cover to transmission case and withdrawal lever and then install dust cover clip.

MT

Recommended sealant: Nissan genuine part (KP115-00100) or equivalent.

AT

TF

PD

FA

RA

BR

ST

BF

HA

EL

IDX

CLUTCH DISC AND CLUTCH COVER

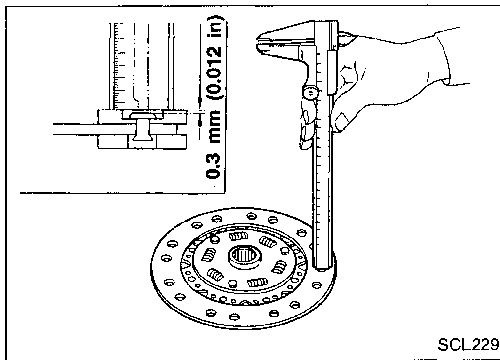
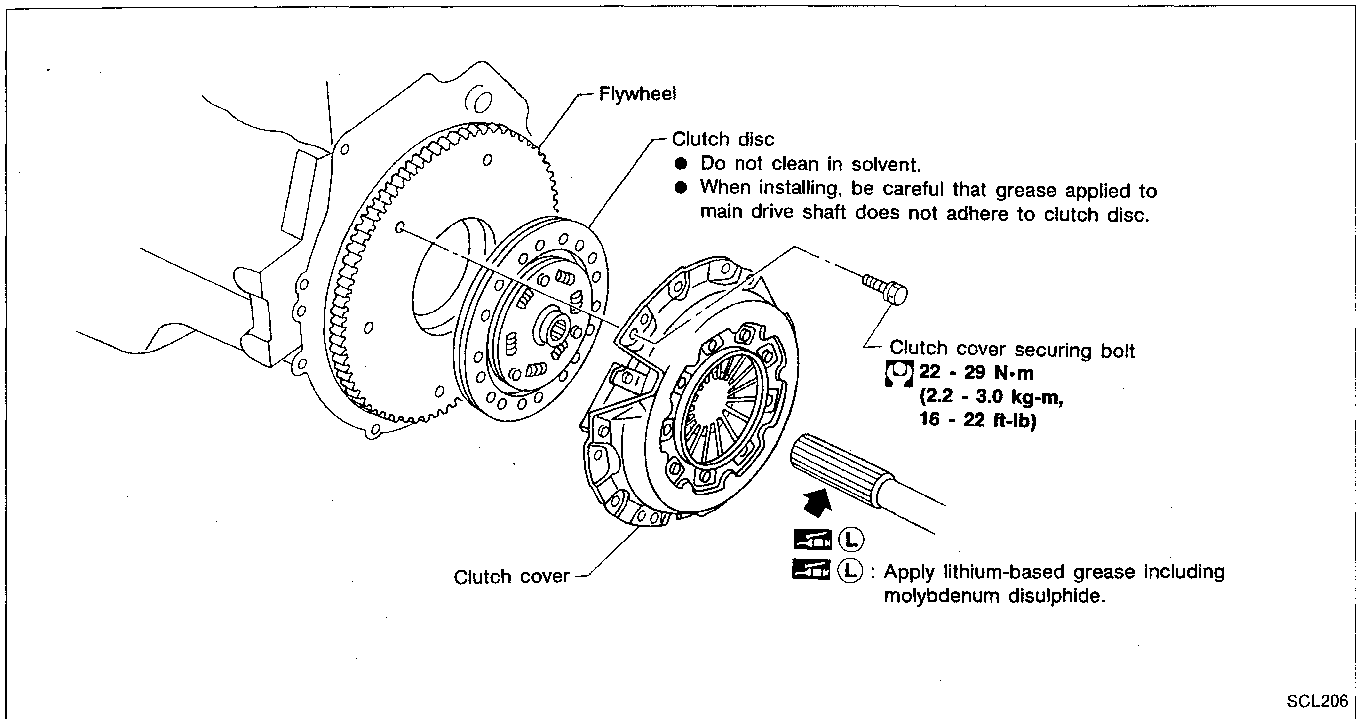

Clutch Disc

INSPECTION

Check clutch disc for wear of facing.

**Wear limit of facing surface to rivet head:
0.3 mm (0.012 in)**

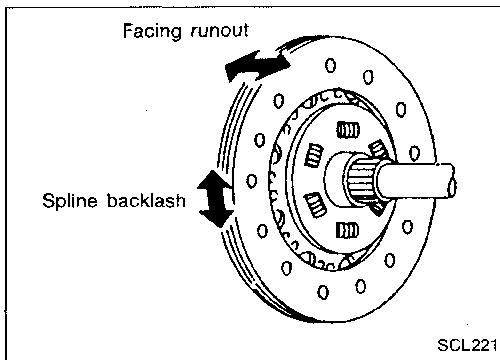

- Check clutch disc for backlash of spline and runout of facing.

**Maximum backlash of spline (at outer edge of disc):
1.0 mm (0.039 in)**

**Runout limit:
1.0 mm (0.039 in)**

**Distance of runout check point (from hub center):
Model 240 115 mm (4.53 in)
Model 250 120 mm (4.72 in)**

- Check clutch disc for burns, discoloration or oil or grease leakage. Replace if necessary.

INSTALLATION

- Apply recommended grease to contact surface of spline portion.

Too much lubricant might cause clutch disc facing damage.

Clutch Cover and Flywheel

INSPECTION AND ADJUSTMENT

- Set Tool and check height and unevenness of diaphragm spring.
- Set 0.2 mm (0.008 in) feeler gauges on distance pieces (ST20050100) when checking model 240 or 250.

Diaphragm spring height "A":

Model 240 37.0 - 39.0 mm (1.457 - 1.535 in)

Model 250 36.5 - 38.5 mm (1.437 - 1.516 in)

- Check thrust rings for wear or damage by shaking cover assembly and listening for a chattering noise, or by lightly hammering on rivets and listening for a cracking noise. Replace clutch cover assembly if necessary.
- Check pressure plate and clutch disc contact surface for slight burns or discoloration. Repair pressure plate with emery paper.
- Check pressure plate and clutch disc contact surface for deformation or damage. Replace if necessary.

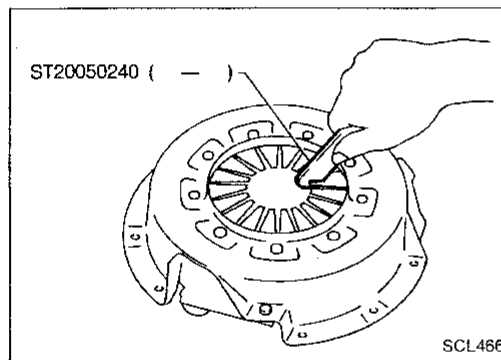
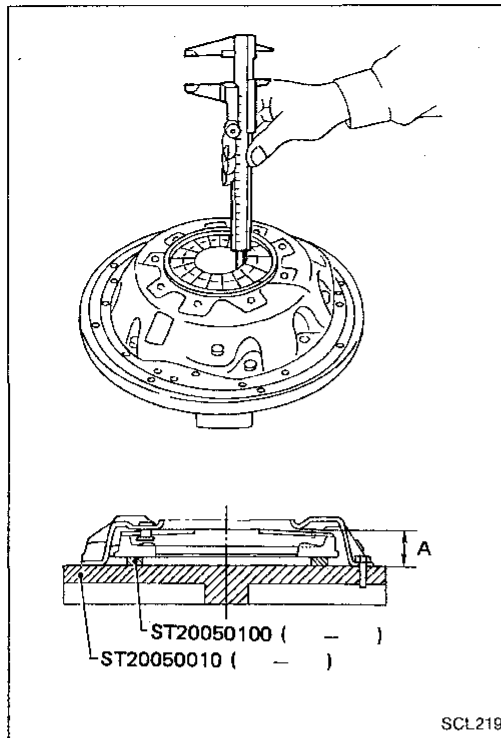

- Adjust unevenness of diaphragm spring with Tool.

Uneven limit:

Model 240 0.5 mm (0.020 in)

Model 250 0.5 mm (0.020 in)

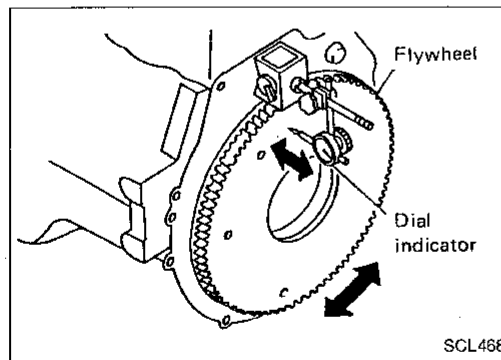

FLYWHEEL INSPECTION

- Check contact surface of flywheel for slight burns or discoloration. Repair flywheel with emery paper.
- Check flywheel runout.

Runout (Total indicator reading):

Flywheel

Refer to EM section. (Inspection — CYLINDER BLOCK)

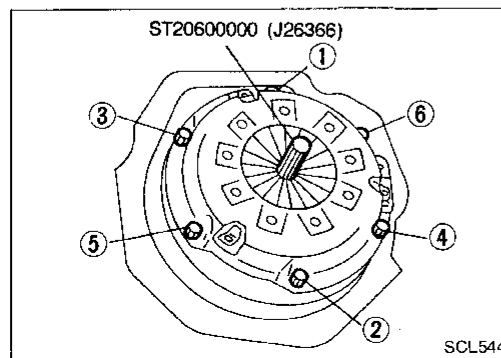

INSTALLATION

- Insert Tool into clutch disc hub when installing clutch cover and disc.
- Tighten clutch cover fixing bolts in numerical order by 2 steps.

Tightening torque:

First step 20 N·m (2.0 kg-m, 14 ft-lb)

Final step 22 - 29 N·m (2.2 - 3.0 kg-m, 16 - 22 ft-lb)

SERVICE DATA AND SPECIFICATIONS (SDS)

General Specifications

CLUTCH MASTER CYLINDER

Inner diameter	mm (in)	15.87 (5/8)
----------------	---------	-------------

CLUTCH OPERATING CYLINDER

Inner diameter	mm (in)	17.46 (11/16)
----------------	---------	---------------

CLUTCH DAMPER

Inner diameter	mm (in)	19.05 (3/4)
----------------	---------	-------------

CLUTCH DISC

Model	240	250
Engine	KA24E	VG30E
Facing size (Outer dia. x inner dia. x thickness)	240 x 150 x 3.5 (9.45 x 5.91 x 0.138)	250 x 160 x 3.5 (9.84 x 6.30 x 0.138)
Thickness of disc assembly With load	7.8 - 8.2 (0.307 - 0.323) with 4,904 N (500 kg, 1,103 lb)	7.9 - 8.3 (0.311 - 0.327) with 5,884 N (600 kg, 1,323 lb)

CLUTCH COVER

Model	240	250
Engine	KA24E	VG30E
Full-load N (kg, lb)	4,413 (450, 992)	4,904 (500, 1,103)

Inspection and Adjustment

CLUTCH PEDAL

Unit: mm (in)

Pedal height*	
KA24E engine model	236 - 246 (9.29 - 9.69)
VG30E engine model	227 - 237 (8.94 - 9.33)
Pedal free play	1.0 - 1.5 (0.039 - 0.059)
Clearance between pedal stopper bracket and threaded end of clutch interlock switch (when depressing clutch pedal fully.)	0.3 - 1.0 (0.012 - 0.039)

*: Measured from surface of melt sheet to pedal pad.

CLUTCH DISC

Unit: mm (in)

Model	240	250
Wear limit of facing surface to rivet head	0.3 (0.012)	
Runout limit of facing	1.0 (0.039)	
Distance of runout check point (from hub center)	115 (4.53)	120 (4.72)
Maximum backlash of spline (at outer edge of disc)	1.0 (0.039)	

CLUTCH COVER

Unit: mm (in)

Model	240	250
Diaphragm spring height	37.0 - 39.0 (1.457 - 1.535)	36.5 - 38.5 (1.437 - 1.516)
Uneven limit of diaphragm spring toe height	0.5 (0.020)	0.5 (0.020)