

DVD Home Theatre System

Operating Instructions

Owner's Record

The model and serial numbers are located on the rear of the unit. Record the serial number in the space provided below. Refer to them whenever you call upon your Sony dealer regarding this product.

Model No. _____ Serial No. _____

HT-7100DH

WARNING

To reduce the risk of fire or electric shock, do not expose this apparatus to rain or moisture.

To prevent fire, do not cover the ventilation of the apparatus with newspapers, table-cloths, curtains, etc. And don't place lighted candles on the apparatus.

To prevent fire or shock hazard, do not place objects filled with liquids, such as vases, on the apparatus.

Do not install the appliance in a confined space, such as a bookcase or built-in cabinet.

Install this system so that the power cord can be unplugged from the wall socket immediately in the event of trouble.



Don't throw away batteries with general house waste; dispose of them correctly as chemical waste.

For customers in the United States

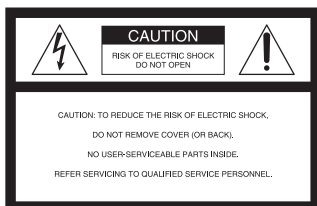

This symbol is intended to alert the user to the presence of uninsulated "dangerous voltage" within the product's enclosure that may be of sufficient magnitude to constitute a risk of electric shock to persons.



This symbol is intended to alert the user to the presence of important operating and maintenance (servicing) instructions in the literature accompanying the appliance.

WARNING

This equipment has been tested and found to comply with the limits for a Class B digital device, pursuant to Part 15 of the FCC Rules. These limits are designed to provide reasonable protection against harmful interference in a residential installation.

This equipment generates, uses, and can radiate radio frequency energy and, if not installed and used in accordance with the instructions, may cause harmful interference to radio communications.

However, there is no guarantee that interference will not occur in a particular installation. If this equipment does cause harmful interference to radio or television reception, which can be determined by turning the equipment off and on, the user is encouraged to try to correct the interference by one or more of the following measures:

- Reorient or relocate the receiving antenna.
- Increase the separation between the equipment and receiver.
- Connect the equipment into an outlet on a circuit different from that to which the receiver is connected.
- Consult the dealer or an experienced radio/TV technician for help.

CAUTION

You are cautioned that any changes or modification not expressly approved in this manual could void your authority to operate this equipment.

Note to CATV system installer:

This reminder is provided to call CATV system installer's attention to Article 820-40 of the NEC that provides guidelines for proper grounding and, in particular, specifies that the cable ground shall be connected to the grounding system of the building, as close to the point of cable entry as practical.

About This Manual

- The instructions in this manual are for model HT-7100DH.

The HT-7100DH consists of:

- Receiver STR-K7100
- DVD player DVP-NC85H
- Speaker system
 - Front speaker SS-MSP7000
 - Center speaker SS-CNP900
 - Surround speaker SS-SRP7000
 - Sub woofer SA-WP780
- The instructions in this manual describe the controls on the supplied remote. You can also use the controls on the receiver if they have the same or similar names as those on the remote.

About area codes

The area code of the receiver you purchased is shown on the lower right portion of the rear panel (see the illustration below).

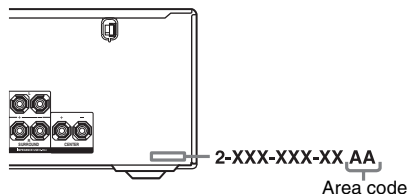

Any differences in operation, according to the area code, are clearly indicated in the text, for example, "Models of area code AA only".

This receiver incorporates Dolby* Digital and Pro Logic Surround and the DTS** Digital Surround System.

- * Manufactured under license from Dolby Laboratories.
"Dolby", "Pro Logic" and the double-D symbol are trademarks of Dolby Laboratories.
- ** "DTS" and "DTS Digital Surround" are trademarks of DTS, Inc.

This receiver incorporates High-Definition Multimedia Interface (HDMI™) technology. HDMI, the HDMI logo and High-Definition Multimedia Interface are trademarks or registered trademarks of HDMI Licensing LLC.

The XM name and related logos are registered trademarks of XM Satellite Radio Inc.

Note for the supplied remote

(RM-AAP016)

The AUX button on the remote is not available for receiver operation.

Table of Contents

Getting Started

| | |
|--|----|
| Description and location of parts..... | 5 |
| 1: Installing speakers | 14 |
| 2: Connecting speakers..... | 16 |
| 3a: Connecting the audio components | 17 |
| 3b: Connecting the video components | 18 |
| 4: Connecting the antennas..... | 26 |
| 5: Preparing the receiver and the remote | 27 |
| 6: Selecting the speaker system..... | 28 |
| 7: Calibrating the appropriate settings automatically (AUTO CALIBRATION) | 29 |
| 8: Adjusting the speaker levels and balance (TEST TONE) | 33 |

Playback

| | |
|-------------------------------------|----|
| Selecting a component..... | 34 |
| Listening/Watching a component..... | 36 |

Amplifier Operations

| | |
|---|----|
| Navigating through menus | 38 |
| Adjusting the level (LEVEL menu)..... | 41 |
| Adjusting the tone (TONE menu)..... | 42 |
| Settings for the surround sound (SUR menu)..... | 42 |
| Settings for the tuner (TUNER menu)..... | 43 |
| Settings for the audio (AUDIO menu) | 43 |
| Settings for the video (VIDEO menu)..... | 44 |
| Settings for the system (SYSTEM menu) ... | 45 |
| Calibrating the appropriate settings automatically (A. CAL menu)..... | 47 |

Enjoying Surround Sound

| | |
|--|----|
| Enjoying Dolby Digital and DTS Surround sound (AUTO FORMAT DIRECT)..... | 47 |
| Selecting a pre-programmed sound field | 49 |
| Using only the front speakers and sub woofer (2CH STEREO) | 51 |
| Resetting sound fields to the initial settings | 52 |

Tuner Operations

| | |
|------------------------------------|----|
| Listening to FM/AM radio..... | 52 |
| Presetting radio stations | 54 |
| Listening to the XM Radio | 56 |
| Presetting XM Radio stations | 60 |

Other Operations

| | |
|--|----|
| Switching the audio input mode (INPUT MODE) | 63 |
| Enjoying the DIGITAL MEDIA PORT (DMPORT) | 63 |
| Listening to digital sound from other inputs (DIGITAL ASSIGN) | 66 |
| Naming inputs..... | 67 |
| Changing the display | 68 |
| Using the Sleep Timer | 68 |
| Recording using the receiver | 69 |

Using the Remote

| | |
|------------------------------|----|
| Programming the remote | 70 |
|------------------------------|----|

Additional Information

| | |
|-----------------------|----|
| Glossary | 75 |
| Precautions | 76 |
| Troubleshooting | 77 |
| Specifications | 81 |
| Index | 83 |

Description and location of parts

Receiver

Front panel

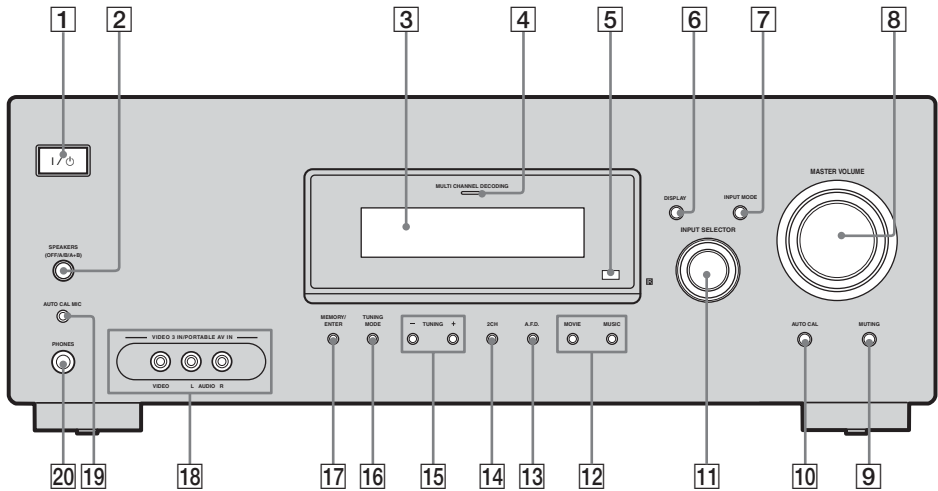

| Name | Function |
|--------------------------------------|---|
| 1 I/O (on/standby) | Press to turn the receiver on or off (page 27, 36, 37, 52, 81). |
| 2 SPEAKERS (OFF/A/B/A+B) | Press to select the speaker system (page 28). |
| 3 Display | The current status of the selected component or a list of selectable items appears here (page 7). |
| 4 MULTI CHANNEL DECODING lamp | Lights up when multi channel audio is decoded (page 37). |
| 5 Remote sensor | Receives signals from remote commander. |

| Name | Function |
|------------------------|---|
| 6 DISPLAY | Press to select information displayed on the display (page 68). |
| 7 INPUT MODE | Press to select the input mode when the same components are connected to both digital and analog jacks (page 63). |
| 8 MASTER VOLUME | Turn to adjust the volume level of all speakers at the same time (page 33, 34, 36, 37). |
| 9 MUTING | Press to mute the sound (page 34). |
| 10 AUTO CAL | Press to activate the Auto Calibration function (page 29). |

| Name | Function |
|--|--|
| 11 INPUT SELECTOR | Turn to select the input source to playback (page 34, 36, 37, 53, 55, 63, 65, 69). |
| 12 MOVIE, MUSIC | Press to select sound fields (MOVIE, MUSIC) (page 49). |
| 13 A.F.D. | Press to select A.F.D. mode (page 47). |
| 14 2CH | Press to select 2CH STEREO mode (page 51, 52). |
| 15 TUNING +/- | Press to scan a station (page 53, 54). |
| 16 TUNING MODE | Press to select the tuning mode (page 55, 81). |
| 17 MEMORY/ENTER | Press to store a station or enter the selection when selecting the settings (page 27). |
| 18 VIDEO 3 IN/ PORTABLE AV IN jacks | Connect to camcorder or video game (page 25, 34). |
| 19 AUTO CAL MIC jack | Connects to the supplied optimizer microphone for the Auto Calibration function (page 29). |
| 20 PHONES jack | Connects to a headphone (page 78). |

About the indicators on the display

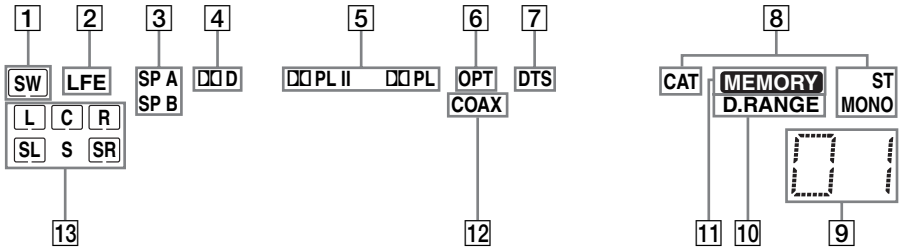

| Name | Function |
|--------------------|---|
| 1 SW | Lights up when the audio signal is output from the SUB WOOFER jack. |
| 2 LFE | Lights up when the disc being played back contains an LFE (Low Frequency Effect) channel and the LFE channel signal is actually being reproduced. |
| 3 SP A/SP B | Lights up according to the speaker system used. However, these indicators do not light up if the speaker output is turned off or if a headphone is connected. |
| 4 DDD | Lights up when the receiver is decoding Dolby Digital signals. Note When playing a Dolby Digital format disc, be sure that you have made digital connections and that INPUT MODE is not set to "ANALOG" (page 63). |
| 5 PL/PL II | "PL" lights up when the receiver applies Pro Logic processing to 2 channel signals in order to output the center and surround channel signals. "PL II" lights up when the Pro Logic II Movie or Music decoder is activated. |

| Name | Function |
|------------------------------------|--|
| 6 OPT | Lights up when VIDEO 2 input is selected. However, "UNLOCK" appears on the display if no digital signal is input through the OPTICAL jack. "OPT" also lights up when SAT input is selected if – INPUT MODE is set to "AUTO IN" and the source signal is a digital signal being input through the OPTICAL jack. – INPUT MODE is set to "OPT IN" (page 63). |
| 7 DTS | Lights up when the receiver is decoding DTS signals. Note When playing a DTS format disc, be sure that you have made digital connections and that INPUT MODE is not set to "ANALOG" (page 63). |
| 8 Tuner indicators | Lights up when using the receiver to tune in radio stations (page 52), etc. |
| 9 Preset station indicators | Lights up when using the receiver to tune in radio stations you have preset. For details on presetting radio stations, see page 54. |
| 10 D.RANGE | Lights up when dynamic range compression is activated (page 41). |

| Name | Function |
|--------------------------------|---|
| 11 MEMORY | Lights up when a memory function, such as Preset Memory (page 54), etc., is activated. |
| 12 COAX | Lights up when INPUT MODE is set to "AUTO IN" and the source signal is a digital signal being input through the COAXIAL jack, or when INPUT MODE is set to "COAX IN" (page 63). |
| 13 Playback channel indicators | <p>The letters (L, C, R, etc.) indicate the channels being played back. The boxes around the letters vary to show how the receiver downmixes the source sound.</p> <p>L Front Left R Front Right C Center (monaural) SL Surround Left SR Surround Right S Surround (monaural or the surround components obtained by Pro Logic processing)</p> <p>Example: Recording format (Front/Surround): 3/2.1 Sound Field: A.F.D. AUTO</p> |

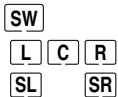

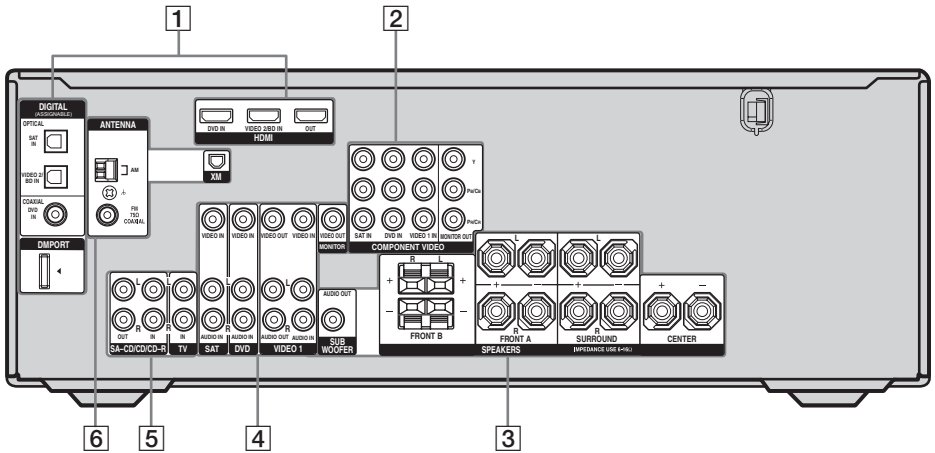

Rear panel



1 DIGITAL INPUT/OUTPUT section

- 

OPTICAL IN jack Connects to a DVD player, etc. The COAXIAL jack provides a better quality of loud sound (page 20, 24).
- 

COAXIAL IN jack Connects to a DVD player, or a Blu-ray disc player. The image and the sound are output to a TV or a projector (page 22).
- 

HDMI IN/OUT jack^{a)} Connect to a DIGITAL MEDIA PORT adapter (page 64).
- 

Connect to a DIGITAL MEDIA PORT adapter (page 64).

2 COMPONENT VIDEO INPUT/OUTPUT section

- 

Green COMPONENT VIDEO INPUT/OUTPUT jack^{a)} Connects to a DVD player, TV, satellite tuner, etc. You can enjoy high quality image (page 19, 21, 24).
- 

Blue COMPONENT VIDEO INPUT/OUTPUT jack^{a)}
- 

Red COMPONENT VIDEO INPUT/OUTPUT jack^{a)}

3 SPEAKER section

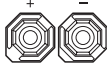
- 

FRONT A SPEAKERS Connects to speakers (page 16).
- 

FRONT B SPEAKER
- 

SUB WOOFER Connects to sub woofer (page 16).

4 VIDEO/AUDIO INPUT/OUTPUT section



- 

White (L) AUDIO IN/OUT jack Connects the video and audio jacks of a VCR or a DVD player (page 19, 20, 21, 24, 25).
- 



Red (R) AUDIO IN/OUT jack
- 

Yellow VIDEO IN/OUT jack^{a)}

5 AUDIO INPUT/OUTPUT section

| | | |
|---|------------------------------|---|
|  | White (L) AUDIO IN/ OUT jack | Connects to Super Audio CD player or CD player, etc. (page 17). |
|  | Red (R) | |

6 ANTENNA section

| | | |
|---|----------------------|--|
|  | FM ANTENNA jack | Connects to the FM wire antenna supplied with this receiver (page 26). |
|  | AM ANTENNA terminals | Connects to the AM loop antenna supplied with this receiver (page 26). |
|  | XM terminal | Connects to the XM connect-and-Play antenna (not supplied with this receiver) (page 57). |

a) You can watch the selected input image when you connect the HDMI OUT or MONITOR OUT jack to a TV (page 19).

Remote commander

You can use the supplied remote to operate the receiver and to control the Sony audio/video components that the remote is assigned to operate.

You can also program the remote to control non-Sony audio/video components. For details, see “Programming the remote” (page 70).



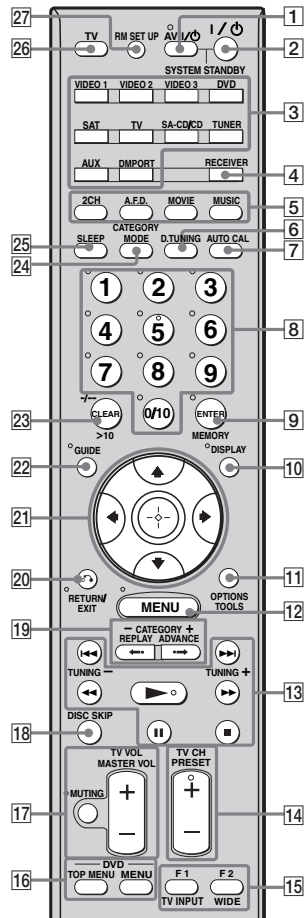





RM-AAP016





















| Name | Function | | | | | | | | | | | | | | | | | | | | | | |
|---------------------------------|--|--------|-------------------------|---------|------------------|---------|------------------|---------|------------------|-----|------------|-----|-----------------|----|----|----------|--------------------------|-------|----------------|-----|--------------|--------|----------------------------|
| 1 AV I/⏻ (on/standby) | <p>Press to turn on or off the audio/video components that the remote is programmed to operate.</p> <p>To turn the TV on or off, press TV (26) and then press AV I/⏻.</p> <p>If you press I/⏻ (2) at the same time, it will turn off the receiver and other components (SYSTEM STANDBY).</p> <p>Note</p> <p>The function of the AV I/⏻ switch changes automatically each time you press the input buttons (3).</p> | | | | | | | | | | | | | | | | | | | | | | |
| 2 I/⏻ (on/standby) | <p>Press to turn the receiver on or off.</p> <p>To turn off all components, press I/⏻ and AV I/⏻ (1) at the same time (SYSTEM STANDBY).</p> | | | | | | | | | | | | | | | | | | | | | | |
| 3 Input buttons | <p>Press one of the buttons to select the component you want to use. When you press any of the input buttons, the receiver turns on. The buttons are factory assigned to control Sony components as follows. You can program the remote to control non-Sony components following the steps in “Programming the remote” on page 70.</p> <table border="1"> <thead> <tr> <th>Button</th> <th>Assigned Sony component</th> </tr> </thead> <tbody> <tr> <td>VIDEO 1</td> <td>VCR (VTR mode 3)</td> </tr> <tr> <td>VIDEO 2</td> <td>VCR (VTR mode 2)</td> </tr> <tr> <td>VIDEO 3</td> <td>VCR (VTR mode 1)</td> </tr> <tr> <td>DVD</td> <td>DVD player</td> </tr> <tr> <td>SAT</td> <td>Satellite tuner</td> </tr> <tr> <td>TV</td> <td>TV</td> </tr> <tr> <td>SA-CD/CD</td> <td>Super Audio CD/CD player</td> </tr> <tr> <td>TUNER</td> <td>Built-in tuner</td> </tr> <tr> <td>AUX</td> <td>Not assigned</td> </tr> <tr> <td>DMPORT</td> <td>DIGITAL MEDIA PORT adapter</td> </tr> </tbody> </table> | Button | Assigned Sony component | VIDEO 1 | VCR (VTR mode 3) | VIDEO 2 | VCR (VTR mode 2) | VIDEO 3 | VCR (VTR mode 1) | DVD | DVD player | SAT | Satellite tuner | TV | TV | SA-CD/CD | Super Audio CD/CD player | TUNER | Built-in tuner | AUX | Not assigned | DMPORT | DIGITAL MEDIA PORT adapter |
| Button | Assigned Sony component | | | | | | | | | | | | | | | | | | | | | | |
| VIDEO 1 | VCR (VTR mode 3) | | | | | | | | | | | | | | | | | | | | | | |
| VIDEO 2 | VCR (VTR mode 2) | | | | | | | | | | | | | | | | | | | | | | |
| VIDEO 3 | VCR (VTR mode 1) | | | | | | | | | | | | | | | | | | | | | | |
| DVD | DVD player | | | | | | | | | | | | | | | | | | | | | | |
| SAT | Satellite tuner | | | | | | | | | | | | | | | | | | | | | | |
| TV | TV | | | | | | | | | | | | | | | | | | | | | | |
| SA-CD/CD | Super Audio CD/CD player | | | | | | | | | | | | | | | | | | | | | | |
| TUNER | Built-in tuner | | | | | | | | | | | | | | | | | | | | | | |
| AUX | Not assigned | | | | | | | | | | | | | | | | | | | | | | |
| DMPORT | DIGITAL MEDIA PORT adapter | | | | | | | | | | | | | | | | | | | | | | |
| 4 RECEIVER | Press to activate the receiver operation (page 33). | | | | | | | | | | | | | | | | | | | | | | |



| Name | Function |
|--|---|
| 5 MUSIC | Press to select sound fields (MUSIC). |
| 2CH | Press to select 2CH STEREO mode. |
| A.F.D. | Press to select A.F.D. mode. |
| MOVIE | Press to select sound fields (MOVIE). |
| 6 D. TUNING | Press to enter direct tuning mode. |
| 7 AUTO CAL | Press to activate the Auto Calibration function. |
| 8 Numeric buttons (number 5 ^a) | <p>Press the numeric buttons to – preset/tune to preset stations.</p> <p>– select track numbers of the CD player, VCD player, LD player, DVD player, MD deck, DAT deck, or tape deck. Press 0/10 to select track number 10.</p> <p>– select channel numbers of the TV, VCR, satellite tuner, Blu-ray disc recorder, hard disc recorder, PSX, DVD/VHS COMBO or DVD/HDD COMBO.</p> <p>Press TV (26) and then press the numeric buttons to select the TV channels.</p> |
| 9 MEMORY | Press MEMORY to store a station. |
| ENTER | <p>Press to enter the value after selecting a channel, disc or track using the numeric buttons of the VCR, CD player, VCD player, LD player, MD deck, DAT deck, tape deck, satellite tuner, Blu-ray disc recorder or PSX.</p> <p>To enter the value of Sony TV, press TV (26) and then press ENTER.</p> |
| 10 DISPLAY | <p>Press to select information displayed on the TV screen of the TV, VCR, VCD player, LD player, DVD player, CD player, MD deck, Blu-ray disc recorder, PSX, satellite tuner, DVD/VHS COMBO or DVD/HDD COMBO.</p> <p>To select information of Sony TV, press TV (26) and then press DISPLAY.</p> |

continued

| Name | Function |
|---|--|
| 11 OPTIONS TOOLS | Press to display and select items from the option menus for DVD player or DVD/VHS COMBO. To display the options of Sony TV, press TV (26) and then press OPTIONS TOOLS. |
| 12 MENU | Press to display the menus of the receiver, VCR, DVD player, satellite tuner, Blu-ray disc recorder, PSX, DVD/VHS COMBO or DVD/HDD COMBO on the TV screen. Then, use the  ,  ,  ,  and  to perform menu operations. To display the menus of Sony TV, press TV (26) and then press MENU. |
| 13  a) b) | Press to start playback of the VCR, CD player, VCD player, LD player, DVD player, MD deck, DAT deck, tape deck, Blu-ray disc recorder, PSX, DVD/VHS COMBO or DVD/HDD COMBO. |
| II ^{b)} | Press to pause playback or recording of the VCR, CD player, VCD player, LD player, DVD player, MD deck, DAT deck, tape deck, Blu-ray disc recorder, PSX, DVD/VHS COMBO, or DVD/HDD COMBO. (Also starts recording with components in recording standby.) |
|  ^{b)} | Press to stop playback of the VCR, CD player, VCD player, LD player, DVD player, MD deck, DAT deck, tape deck, Blu-ray disc recorder, PSX, DVD/VHS COMBO or DVD/HDD COMBO. |
|   b) | Press to – search tracks in the forward/backward direction of the CD player, VCD player, DVD player, LD player, MD deck, Blu-ray disc recorder, PSX, DVD/VHS COMBO, or DVD/HDD COMBO. – fast forward/rewind of the VCR, DAT deck, or tape deck. |

| Name | Function |
|---|--|
|   b) | Press to skip tracks of the VCR, CD player, VCD player, LD player, DVD player, MD deck, DAT deck, tape deck, Blu-ray disc recorder, PSX, DVD/VHS COMBO, or DVD/HDD COMBO. |
| TUNING +/- | Press to scan a station. |
| 14 TV CH +^{a)}/- | Press TV (26) and then press TV/CH +/- to select preset TV channels. |
| PRESET +^{a)}/- | Press to – select preset stations. – select preset channels of the TV, VCR, satellite tuner, Blu-ray disc recorder, DVD player, DVD/VHS COMBO or DVD/HDD COMBO. |
| 15 F1, F2 | Press F1 or F2 to select a component to operate. – DVD/HDD COMBO F1: HDD mode F2: DVD mode – DVD/VHS COMBO F1: DVD mode F2: VHS mode |
| TV/INPUT | Press TV (26) and then press TV/INPUT to select the input signal (TV input or video input). |
| WIDE | Press TV (26) and then press WIDE to select the wide picture mode. |
| 16 DVD TOP MENU | Press to display the menu or on-screen guide of the DVD player on the TV screen. Then, use the  ,  ,  ,  and  to perform menu operations. |
| DVD MENU | Press to display the menu of the DVD player on the TV screen. Then, use the  ,  ,  ,  and  to perform menu operations. |
| 17 TV VOL +/- | Press TV (26) and then press TV VOL to adjust the TV volume level. |
| MASTER VOL +/- | Press to adjust the volume level of all speakers at the same time. |
| MUTING | Press to mute the sound. To mute the sound of the TV, press TV (26) and then press MUTING. |

| Name | Function |
|---|---|
| 18 DISC SKIP | Press to skip disc of the CD player, VCD player, DVD player or MD deck (multi-disc changer only). |
| 19 CATEGORY +/- | Press to select the category for XM Radio. |
| REPLAY ←/ ADVANCE → | Press to replay the previous scene or fast forward the current scene of the DVD player, Blu-ray disc recorder, DVD/VHS COMBO or DVD/HDD COMBO. |
| 20 RETURN/ EXIT ↻ | Press to – return to the previous menu. – exit the menu while the menu or on-screen guide of the VCD player, LD player, DVD player, Blu-ray disc recorder, PSX, DVD/VHS COMBO, or satellite tuner is displayed on the TV screen. To return to the previous menu of Sony TV, press TV (26) and then press RETURN/EXIT ↻. |
| 21  ,  | After pressing RECEIVER (4), then press MENU (12) for receiver operation, press  to select the settings. After pressing DVD TOP MENU (16) or DVD MENU (16), press  to select the settings, and then press  to enter the selection. Press  also, to enter the selection of the receiver, VCR, satellite tuner, CD player, DVD player or Blu-ray disc recorder, PSX, DVD/VHS COMBO or DVD/HDD COMBO. |
| 22 GUIDE | Press to display the EPG (Electronic Program Guide) of the TV, DVD player, Satellite tuner, Blu-ray disc recorder, PSX or DVD/HDD COMBO. |
| 23 -/-- | Press to select the channel entry mode, either one or two digit of the VCR or satellite tuner. To select the channel entry mode of the TV, press TV (26) and then press -/--. |

| Name | Function |
|-------------------------|--|
| CLEAR | Press to clear a mistake when you press the incorrect numeric button of the DVD player, Blu-ray disc recorder, PSX, satellite tuner, DVD/VHS COMBO or DVD/HDD COMBO. |
| >10 | Press to select track numbers over 10 of the CD player, VCD player, LD player, MD deck, tape deck, TV, VCR or satellite tuner. |
| 24 CATEGORY MODE | Press to select the category mode for XM Radio. |
| 25 SLEEP | Press to activate the Sleep Timer function and the duration which the receiver turns off automatically. |
| 26 TV | Press to light up the button. It changes the remote key function to activate the buttons with orange printing. It also activate the DISPLAY (10), OPTIONS TOOLS (11), MENU (12), RETURN/EXIT ↻ (20),  (21) and  (21) buttons to perform menu operations for Sony TVs only. |
| 27 RM SET UP | Press to set up the remote. |

- a) The number 5, PRESET +, TV CH + and  buttons have tactile dots. Use the tactile dots as references when operating the receiver.
- b) The button is also available for DIGITAL MEDIA PORT adapter operation. For details on the function of the buttons, see the operating instructions supplied with the DIGITAL MEDIA PORT adapter.

Notes

- Some functions explained in this section may not work depending on the model.
- The above explanation is intended to serve as an example only. Therefore, depending on the component, the above operation may not be possible or may operate differently than described.
- The AUX on the remote is not available for receiver operation.

1: Installing speakers

To fully enjoy theater-like multi channel surround sound requires five speakers (two front speakers, a center speaker, and two surround speakers) and a sub woofer (5.1 channel).

Example of a 5.1 channel speaker system configuration

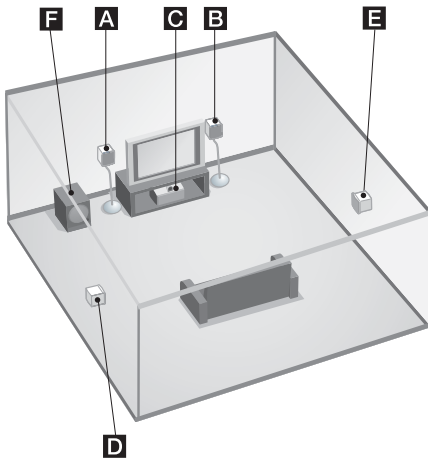

- A** Front speaker (Left)
- B** Front speaker (Right)
- C** Center speaker
- D** Surround speaker (Left)
- E** Surround speaker (Right)
- F** Sub woofer

Tip

Since the sub woofer does not emit highly directional signals, you can place it wherever you want.

Installing the speakers on a flat surface

Before you install the speakers and sub woofer, be sure to attach the supplied foot pads to prevent vibration or movement as shown in the illustration below.

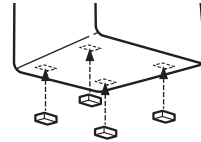

Installing the speakers on the speaker stand

For greater flexibility in positioning the speakers, use the optional WS-FV11 speaker stand (available only in certain countries). For details, refer to the operating instructions supplied with the speaker stand

Installing the speakers on the wall

You can install your surround speakers on the wall.

- 1 Prepare screws (not supplied) that are suitable for the hook on the back of each speaker as shown in the illustrations below.**

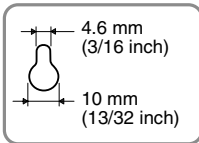
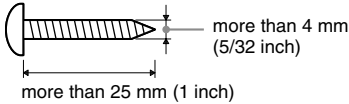

Hook on the back of the speaker

- 2 Fasten the screws to the wall. The screws should protrude 5 to 7 mm.**

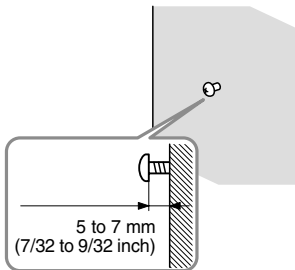

- 3 Hang the speakers on the screws.**

Hook on the back of the speaker

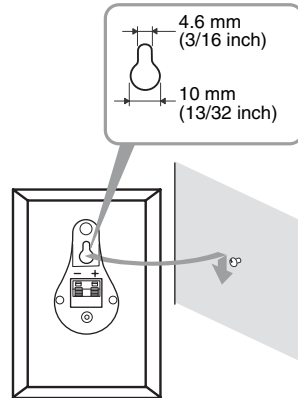

Notes

- Use screws that are suitable for the wall material and strength. As a plaster board wall is especially fragile, attach the screws securely to a beam and fasten them to the wall. Install the speakers on a vertical and flat wall where reinforcement is applied.
- Contact a screw shop or installer regarding the wall material or screws to be used.
- Sony is not responsible for accident or damage caused by improper installation, insufficient wall strength or improper screw installation, natural calamity, etc.

2: Connecting speakers

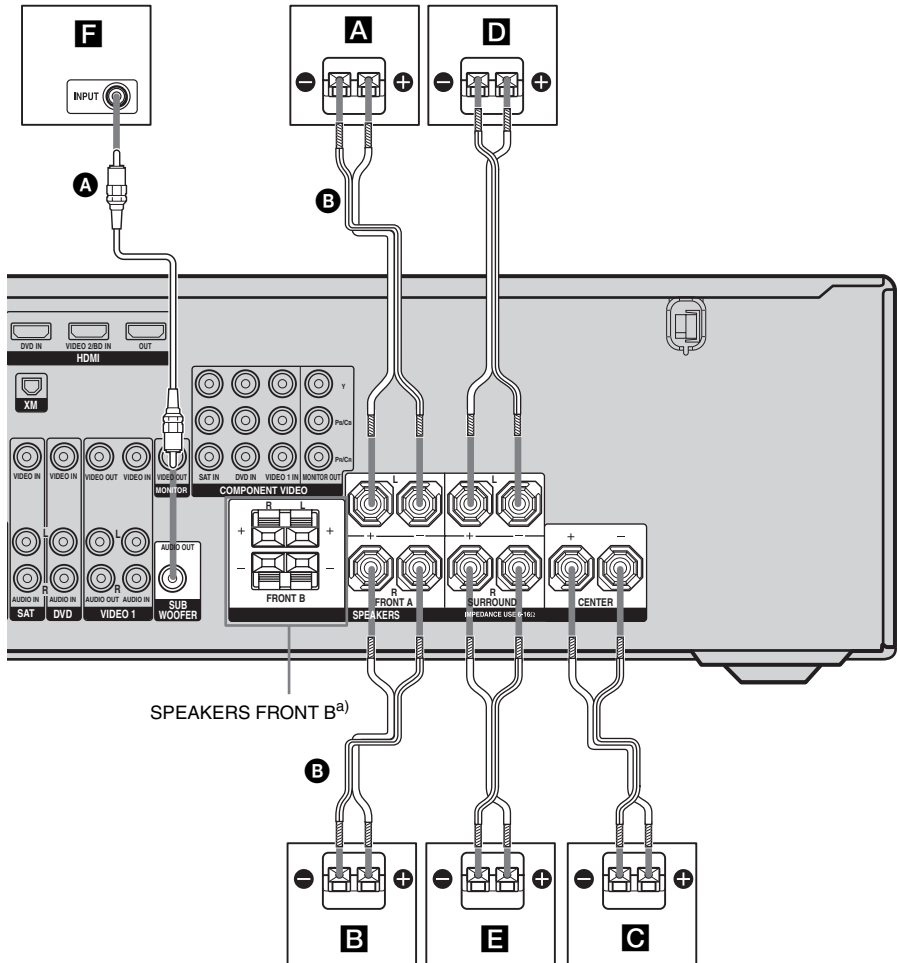

- A** Monaural audio cord (supplied)
- B** Speaker cords (supplied)^{b)}

- A** Front speaker A (Left)
- B** Front speaker A (Right)
- C** Center speaker
- D** Surround speaker (Left)
- E** Surround speaker (Right)
- F** Sub woofer

^{a)} If you have an additional front speaker system, connect them to the SPEAKERS FRONT B terminal. You can select the front speakers you want to use with the SPEAKERS (OFF/A/B/A+B) button. For details, see “6: Selecting the speaker system” (page 28).

^{b)} Use the long speaker cords to connect the surround speakers and the short speaker cords to connect the front and center speakers.

To connect the speakers correctly

Check the speaker type by referring to the speaker label* on the rear panel of the speakers.

| Character on speaker label | Speaker type |
|----------------------------|----------------|
| L | Front left |
| R | Front right |
| SL | Surround left |
| SR | Surround right |

* The center speaker and sub woofer do not have any character on the speaker label. For details on the speaker type, see page 3.

Tip

Use the supplied speakers to optimize the system's performance.

3a: Connecting the audio components

Connecting a Super Audio CD/CD player/CD recorder

The following illustration shows how to connect a Super Audio CD player, CD player or CD recorder.

After connecting your audio component, proceed to “3b: Connecting the video components” (page 18) or “4: Connecting the antennas” (page 26).

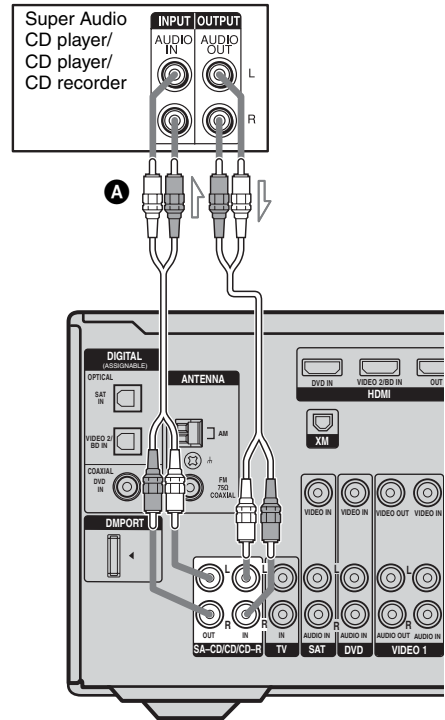

A Audio cord (not supplied)

3b: Connecting the video components

How to hook up your components

This section describes how to hook up your components to this receiver. Before you begin, refer to “Component to be connected” below for the pages which describe how to connect each component.

After hooking up all your components, proceed to “4: Connecting the antennas” (page 26).

Component to be connected

| Component | Page |
|-----------------------------|------|
| TV | 19 |
| DVD player/DVD recorder | 20 |
| With HDMI jack | 22 |
| Satellite tuner/Set-top box | 24 |
| VCR | 25 |
| Camcorder, video game, etc. | 25 |

Video input/output jack to be connected

The image quality depends on the connecting jack. Refer to the illustration that follows. Select the connection according to the jacks on your components.

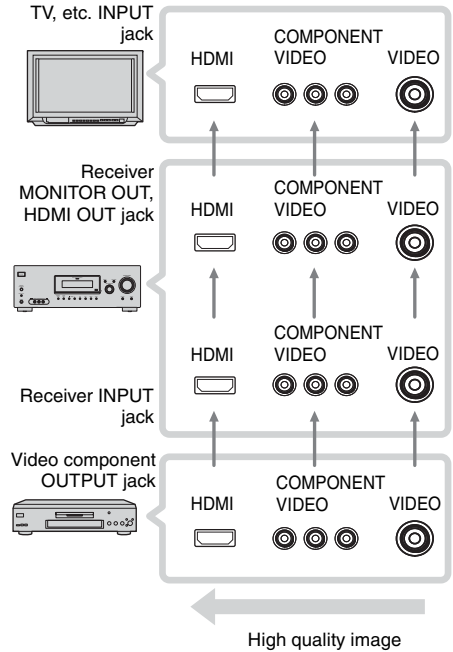

Notes

- Connect image display components such as a TV or a projector to the HDMI OUT or MONITOR OUT jack on the receiver.
- Turn on the receiver when the video and audio of a playback component are being output to a TV through the receiver. If the power supply of the receiver is not on, neither video nor audio is transmitted.

Connecting a TV

The image from a visual component connected to this receiver and the menu of this receiver can be displayed on a TV screen.

It is not necessary to connect all the cables.

Connect audio and video cords according to the jacks of your components.

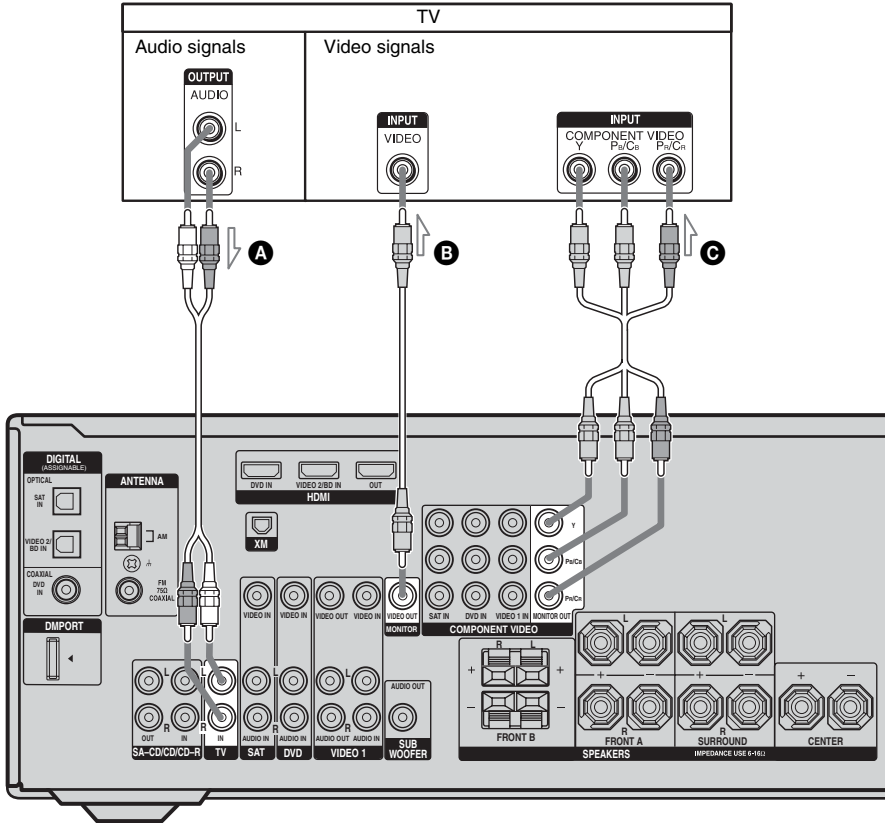

- A** Audio cord (not supplied)
- B** Video cord (not supplied)
- C** Component video cord (not supplied)

Notes

- Connect image display components such as a TV or a projector to the MONITOR OUT jack on the receiver.
- Turn on the receiver when the video and audio of a playback component are being output to a TV via the receiver. If the power supply of the receiver is not turned on, neither video nor audio is transmitted.

Tips

- You can watch the selected input image when you connect the MONITOR OUT jack to a TV.
- To output the sound of the TV from the speakers connected to the receiver, be sure to
 - connect the audio output jacks of the TV to the TV IN jack of the receiver.
 - turn off or mute the TV's volume.

Connecting a DVD player/DVD recorder

The following illustration shows how to connect a DVD player/DVD recorder. It is not necessary to connect all the cables. Connect audio and video cords according to the jacks of your components.

Connecting a DVD player

Notes

- To input multi channel digital audio from the DVD player, set the digital audio output setting on the DVD player. Refer to the operating instructions supplied with the DVD player.
- When connecting optical digital cords, insert the plugs straight in until they click into place.
- Do not bend or tie the optical digital cords.

Tip

All the digital audio jacks are compatible with 32 kHz, 44.1 kHz, 48 kHz, and 96 kHz sampling frequencies.

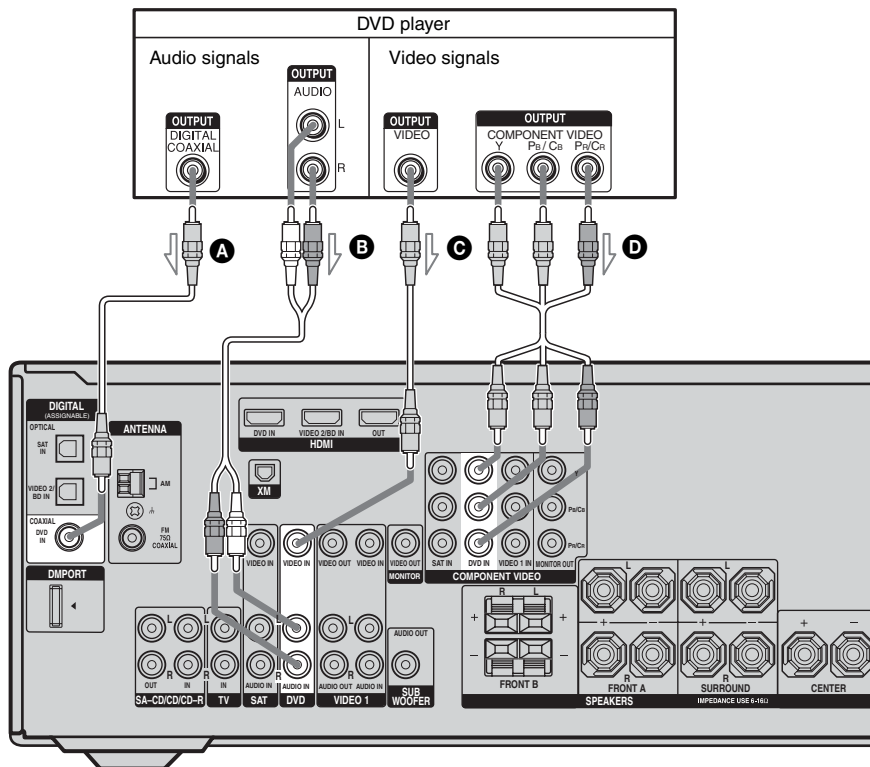

- A** Coaxial digital cord (supplied)
- B** Audio cord (not supplied)
- C** Video cord (not supplied)
- D** Component video cord (not supplied)

Connecting a DVD recorder

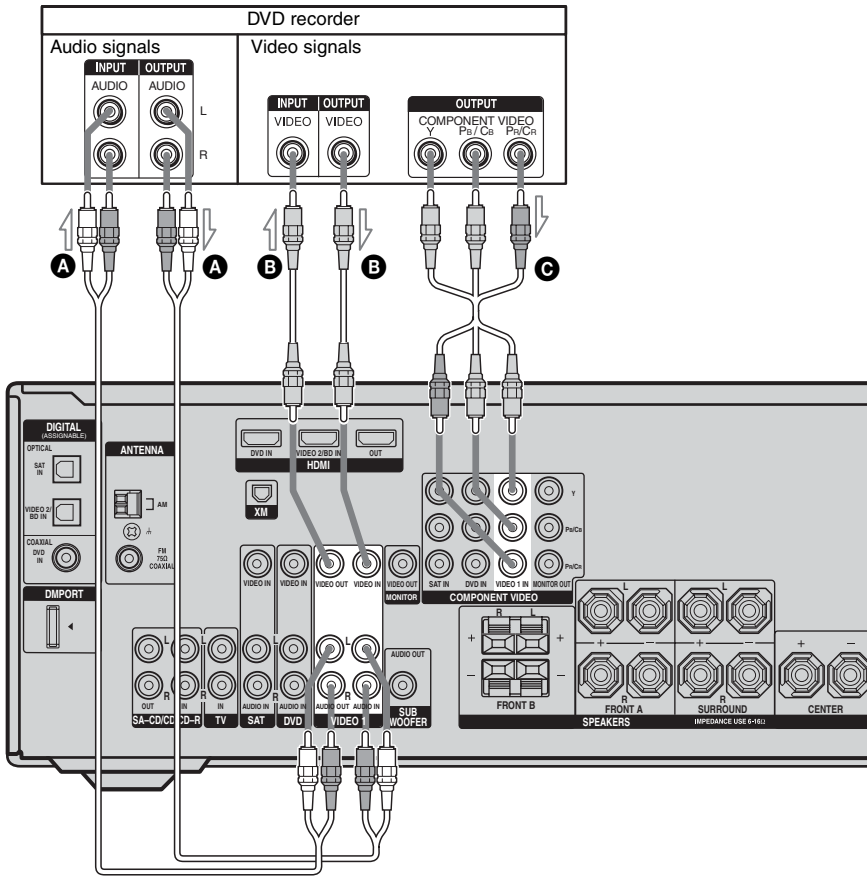

- A** Audio cord (not supplied)
- B** Video cord (not supplied)
- C** Component video cord (not supplied)

- Be sure to change the factory setting of the VIDEO 1 input button on the remote so that you can use the button to control your DVD recorder. For details, see “Programming the remote” (page 70).
- You can also rename the VIDEO 1 input so that it can be displayed on the receiver’s display. For details, see “Naming inputs” (page 67).

Connecting components with HDMI jacks

HDMI is the abbreviated name for High-Definition Multimedia Interface. It is an interface which transmits video and audio signals in digital format.

The sound is output from the TV speaker only when a playback component and this receiver, as well as this receiver and the TV are connected via a HDMI jack. To output the sound from the supplied speakers and to take advantage of the multi channel surround sound, be sure to

- connect the digital audio jacks on the playback component to the receiver.
- turn off or mute the TV's volume.

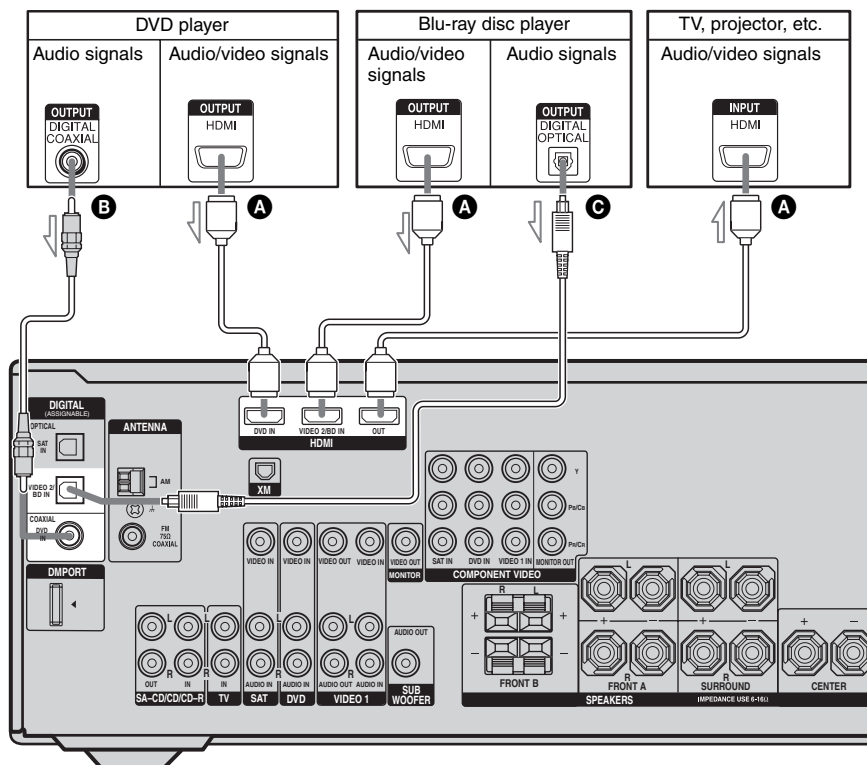

A HDMI cable (not supplied)

We recommend that you use a Sony HDMI cable.

B Coaxial digital cord (supplied)

C Optical digital cord (not supplied)

If you connect a Blu-ray disc player

- Be sure to change the factory setting of the VIDEO 2 input button on the remote so that you can use the button to control your blu-ray disc player. For details, see “Programming the remote” (page 70).
- You can also rename the VIDEO 2 input so that it can be displayed on the receiver’s display. For details, see “Naming inputs” (page 67).

Notes on HDMI connections

- This receiver may not be able to transfer video or audio signals with certain types of components.
- The multi/stereo area audio signals of a Super Audio CD are not output.
- Be sure to turn on the receiver when the video and audio of a playback component are being output to a TV via the receiver. If the power supply of the receiver is not turned on, neither video nor audio is transmitted.
- Audio signals (sampling frequency, bit length, etc.) transmitted from a HDMI jack may be restricted by the connected component. Check the setup of the connected component if the image is poor or the sound does not come out of a component connected via the HDMI cable.
- Video signals input to the HDMI IN jack can only be output from the HDMI OUT jack. The input video signals cannot be output from the VIDEO OUT or MONITOR OUT jacks.
- Refer to the operating instructions of each component connected for details.

Notes on digital audio signals connection

- When connecting optical digital cords, insert the plugs straight in until they click into place.
- Do not bend or tie optical digital cords.
- All the digital audio jacks are compatible with 32 kHz, 44.1 kHz, 48 kHz, and 96 kHz sampling frequencies.

Connecting a satellite tuner/ Set-top box

The following illustration shows how to connect a satellite tuner or set-top box. It is not necessary to connect all the cables. Connect audio and video cords according to the jacks of your components.

Notes

- When connecting optical digital cords, insert the plugs straight in until they click into place.
- Do not bend or tie optical digital cords.

Tip

All the digital audio jacks are compatible with 32 kHz, 44.1 kHz, 48 kHz, and 96 kHz sampling frequencies.

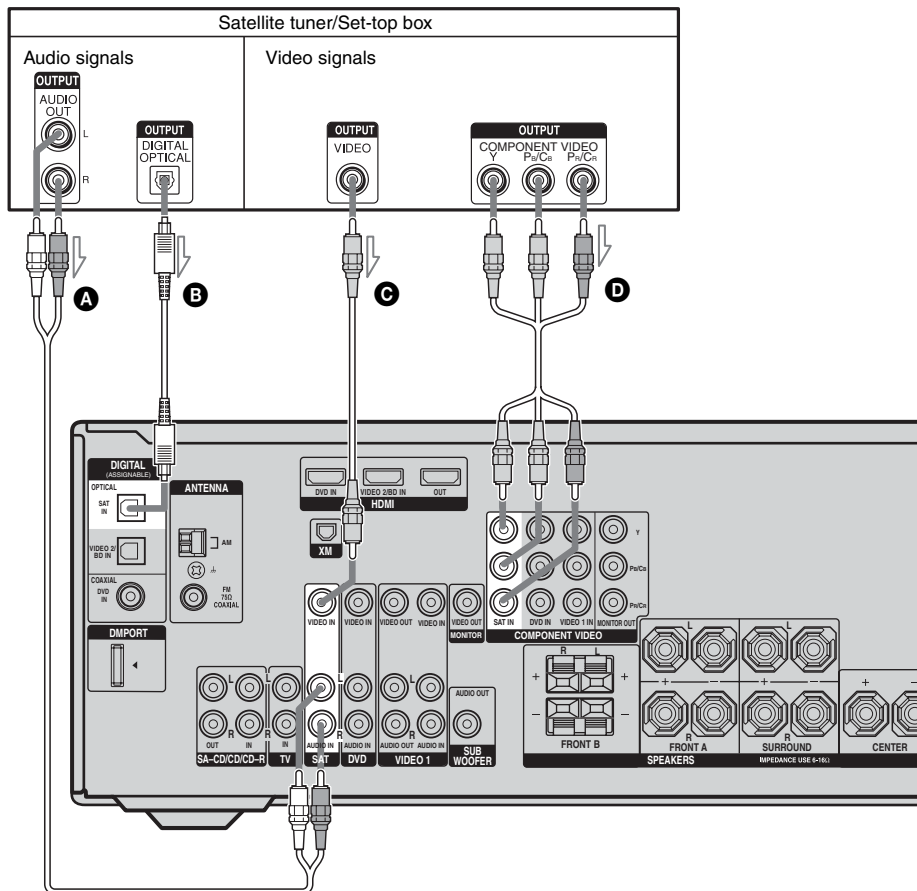

- A** Audio cord (not supplied)
- B** Optical digital cord (not supplied)
- C** Video cord (not supplied)
- D** Component video cord (not supplied)

Connecting components with analog video and audio jack

The following illustration shows how to connect a component which has analog jacks such as a VCR, etc.

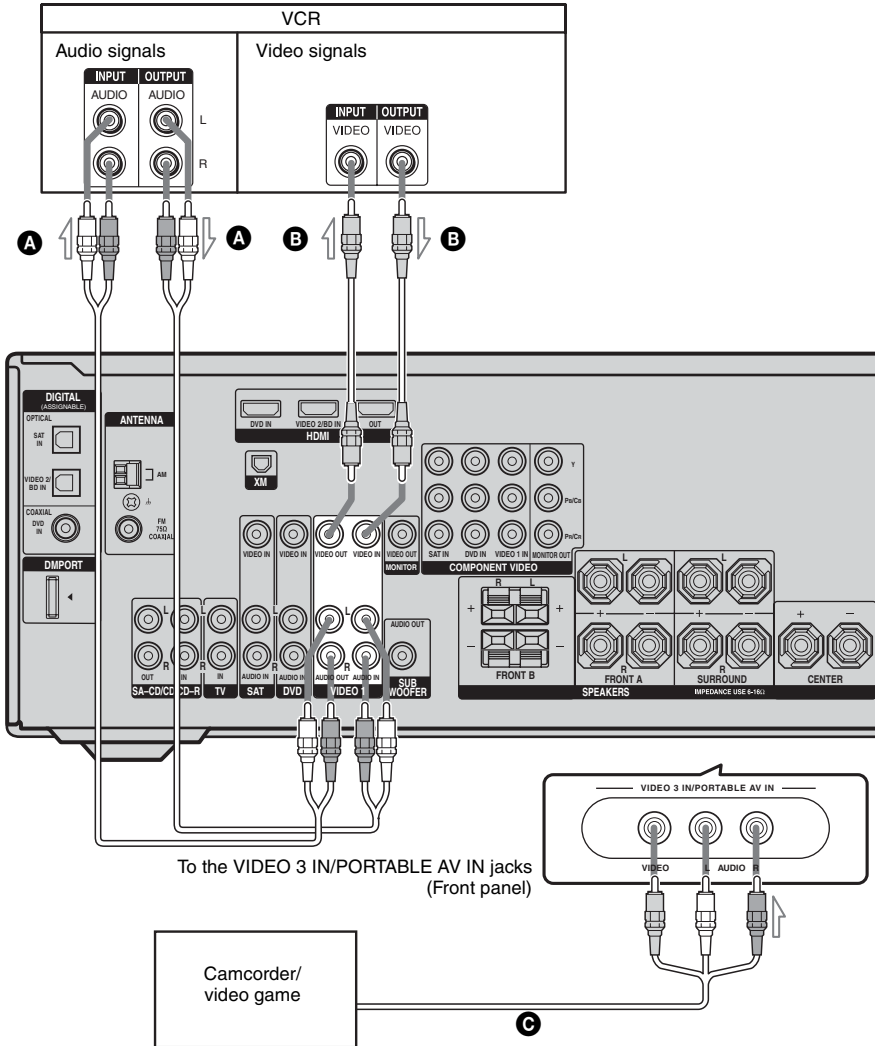

To the VIDEO 3 IN/PORTABLE AV IN jacks (Front panel)

- A** Audio cord (not supplied)
- B** Video cord (not supplied)
- C** Audio/video cord (not supplied)

4: Connecting the antennas

Connect the supplied AM loop antenna and FM wire antenna.

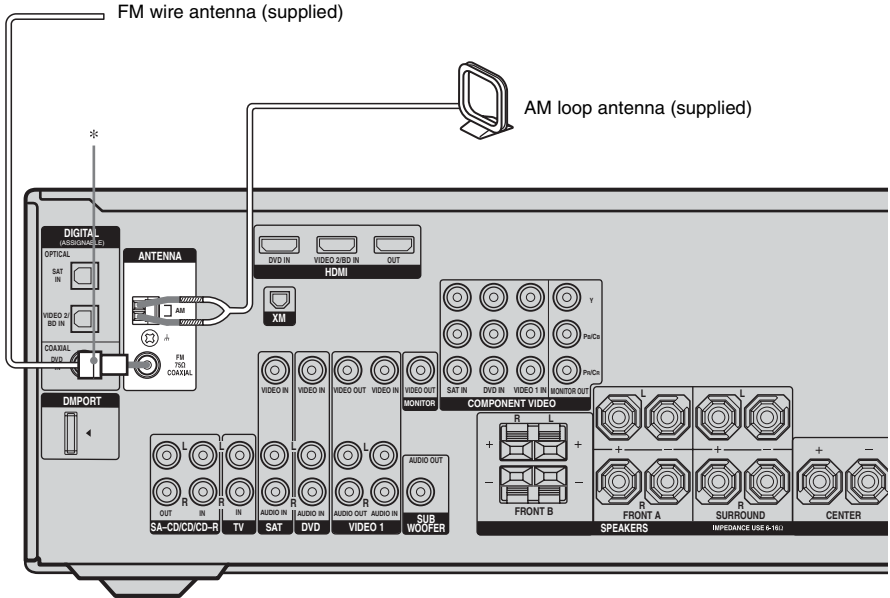

* The shape of the connector varies depending on the area code of this receiver.

Notes

- To prevent noise pickup, keep the AM loop antenna away from the receiver and other components.
- Be sure to fully extend the FM wire antenna.
- After connecting the FM wire antenna, keep it as horizontal as possible.

5: Preparing the receiver and the remote

Connecting the AC power cord

Connect the AC power cord to a wall outlet.

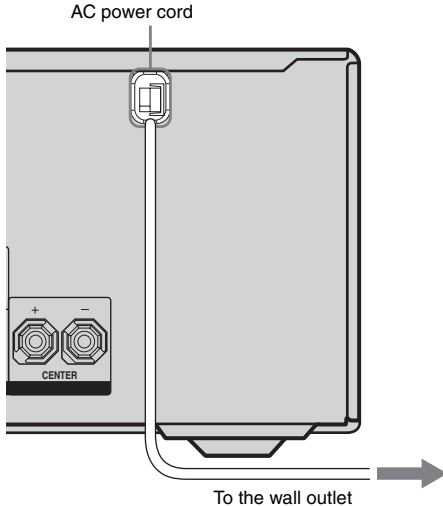

Performing initial setup operations

Before using the receiver for the first time, initialize the receiver by performing the following procedure. This procedure can also be used to return settings you have made to their factory defaults.

Be sure to use the buttons on the receiver for this operation.

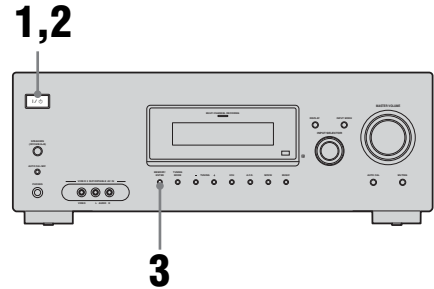

1 Press **I/⏻** to turn off the receiver.

2 Hold down **I/⏻** for 5 seconds. “PUSH” and “ENTER” appears on the display alternately.

3 Press **MEMORY/ENTER**.

After “CLEARING” appears on the display for a while, “CLEARED” appears.

The following items are reset to their factory settings.

- All settings in the LEVEL, TONE, SUR, TUNER, AUDIO, VIDEO and SYSTEM menus.
- The sound field memorized for each input and preset station.
- All sound field parameters.
- All preset stations.
- All index names for inputs and preset stations.
- MASTER VOLUME is set to “VOL MIN”.
- Input is set to “DVD”.

Inserting batteries into the remote

Insert two R6 (size-AA) batteries in the RM-AAP016 remote commander. Observe the correct polarity when installing batteries.

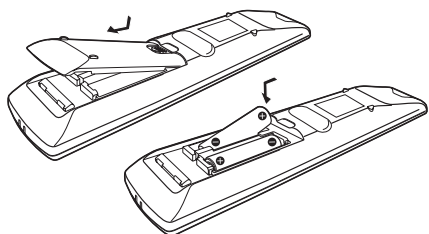

Notes

- Do not leave the remote in an extremely hot or humid place.
- Do not use a new battery with old ones.
- Do not mix alkaline batteries and other kinds of batteries.
- Do not expose the remote sensor to direct sunlight or lighting apparatuses. Doing so may cause a malfunction.
- If you do not intend to use the remote for an extended period of time, remove the batteries to avoid possible damage from battery leakage and corrosion.
- When you replace the batteries, the remote buttons may be reset to their factory settings. If this happens, reassign the buttons again (page 70).

Tip

Under normal conditions, the batteries should last for about 3 months. When the remote no longer operates the receiver, replace all the batteries with new ones.

6: Selecting the speaker system

You can select the front speakers you want to drive.

Be sure to use the buttons on the receiver for this operation.

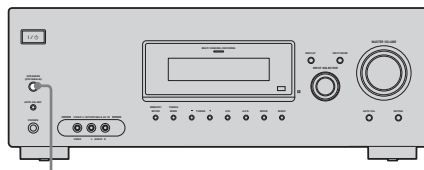

SPEAKERS
(OFF/A/B/A+B)

Press SPEAKERS (OFF/A/B/A+B) repeatedly to select the front speaker system you want to drive.

| To select | Light up |
|---|---------------|
| The speakers connected to the SPEAKERS FRONT A terminals | SP A |
| The speakers connected to the SPEAKERS FRONT B terminals | SP B |
| The speakers connected to both the SPEAKERS FRONT A and B terminals (parallel connection) | SP A and SP B |

To turn off the speaker output

Press SPEAKERS (OFF/A/B/A+B) repeatedly until the “SP A” and “SP B” indicators on the display do not light up.

Note

You cannot switch the front speakers by pressing SPEAKERS (OFF/A/B/A+B) when the headphones are connected.

7: Calibrating the appropriate settings automatically (AUTO CALIBRATION)

This receiver is equipped with D.C.A.C. (Digital Cinema Auto Calibration) Technology which allows you to perform automatic calibration as follows:

- Check the connection between each speaker and the receiver.
- Adjust the speaker level.
- Measure the distance of each speaker to your listening position.

You can also adjust the speaker levels and balance manually. For details, see “8: Adjusting the speaker levels and balance (TEST TONE)” (page 33).

Before you perform Auto Calibration

Before you perform the auto calibration, set up and connect the speakers (page 16, 17).

- The AUTO CAL MIC jack is used for the supplied optimizer microphone only. Do not connect other microphones to this jack. Doing so may damage the receiver and the microphone.
- During the calibration, the sound that comes out of the speakers is very loud. Pay attention to the presence of children or to the effect on your neighborhood.
- Perform the auto calibration in a quiet environment to avoid the effect of noise and get a more accurate measurement.
- If there are any obstacles in the path between the optimizer microphone and the speakers, the calibration cannot be performed correctly. Remove any obstacles from the measurement area to avoid measurement error.

Notes

- The Auto Calibration function does not work when headphones are connected.
- If the Muting function is on when we perform Auto Calibration, it will turn off automatically.

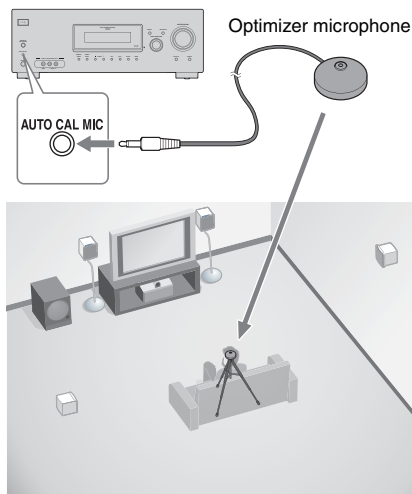

1 Connect the supplied optimizer microphone to the AUTO CAL MIC jack on the front panel.

2 Set up the optimizer microphone. Place the optimizer microphone at your listening position. Use a stool or tripod so that the optimizer microphone remains at the same height as your ears.

Tip

When you face the speaker towards the optimizer microphone, you will get a more accurate measurement.

Performing Auto Calibration

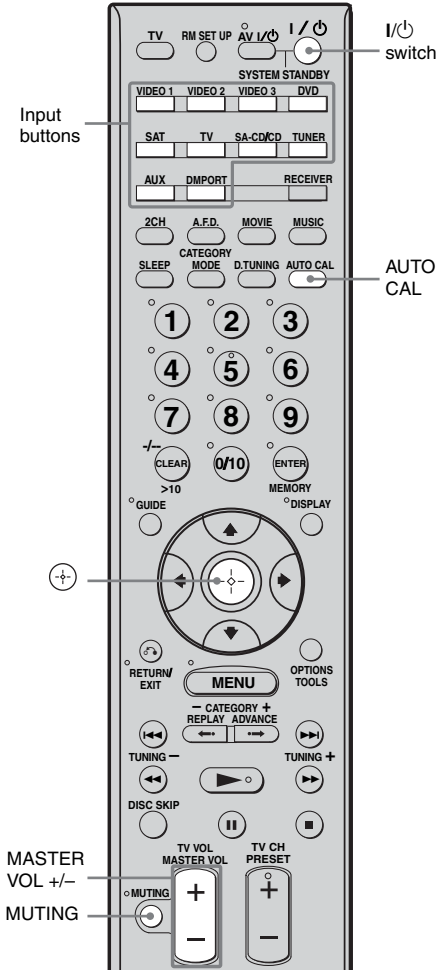

Press AUTO CAL.

The following appears on the display.
 A.CAL [5] → A.CAL [4] → A.CAL [3] →
 A.CAL [2] → A.CAL [1]

The measurement process will take a few minutes to complete.

The table below shows the display when measurement starts.

| Measurement for | Display |
|-------------------------|---|
| Environment noise level | NOISE.CHK |
| Speaker connection | MEASURE and SP DET. appears alternately* |
| Speaker level | MEASURE and GAIN appears alternately* |
| Speaker distance | MEASURE and DISTANCE appears alternately* |

* The corresponding speaker indicator lights up in the display during measurement.

When measurement ends, “COMPLETE” appears on the display and the settings are registered.

When you have finished

Disconnect the optimizer microphone from the receiver.

Notes

- Auto Calibration cannot detect the sub woofer. Therefore, all sub woofer settings will be maintained.
- You cannot select Auto Calibration when headphone is connected.

Tips

- When Auto Calibration starts:
 - Stand some distance from the speakers and the listening position to avoid measurement failure. This is because test signals are output from the speakers during measurement.
 - Avoid making noise to get a more accurate measurement.
- The Auto Calibration function will be canceled when you do the following during the measurement process:
 - Press I/switch, input buttons or MUTING.
 - Change the volume level.
 - Press AUTO CAL again.

Error and warning codes

Error codes

When an error is detected during Auto Calibration, an error code will appear on the display cyclically after each measurement process as follows:

Error code → blank display → (error code → blank display)^{a)} → PUSH → blank display → ENTER

^{a)} Appears when there are more than one error code.

To rectify the error

- 1 Record down the error code.
- 2 Press RECEIVER.
The RECEIVER indicator lights up and receiver operation is activated.
- 3 Press \oplus .
- 4 Press I/off to turn off the receiver.
- 5 Rectify the error.
For details, see “Error codes and remedies” below.
- 6 Turn on the receiver and perform Auto Calibration again (page 30).

Error codes and remedies

| Error code | Explanation | Remedy |
|------------|--|---|
| ERROR 10 | The environment is too noisy. | Make sure the environment is quiet during Auto Calibration. |
| ERROR 11 | The speakers are placed too near the optimizer microphone. | Place your speakers further away from the optimizer microphone. |
| ERROR 12 | None of the speakers are detected. | Make sure that the optimizer microphone is connected properly and perform Auto Calibration. |
| ERROR 20 | Front speakers are not detected or only one front speaker is detected. | Check the front speaker connection. |
| ERROR 21 | Only one surround speaker is detected. | Check the surround speaker connection. |

Warning codes

During Auto Calibration, the warning code provides information on the measurement result. The warning code will appear on the display cyclically as follows:

Warning code → blank display → (warning code → blank display)^{b)} → PUSH → blank display → ENTER

^{b)} Appears when there are more than one warning code.

You can choose to ignore the warning code as the Auto Calibration function will automatically adjust the settings. You can also change the settings manually.

To change the settings manually

- 1 Record down the warning code.
- 2 Press RECEIVER.
The RECEIVER indicator lights up and receiver operation is activated.
- 3 Press (+).
- 4 Press I/⏻ to turn off the receiver.
- 5 Follow the solution provided in the “Warning codes and solutions” below.
- 6 Turn on the receiver and perform Auto Calibration again (page 30).

Warning codes and solutions

| Warning code | Explanation | Solution |
|--------------|--|---|
| WARN. 40 | The environment is noisy. | Make sure the environment is quiet during Auto Calibration. |
| WARN. 50 | The center speaker is not connected. | Be sure to connect the center speaker. |
| WARN. 51 | The surround speakers are not connected. | Be sure to connect the surround speakers. |
| WARN. 60 | The front speaker balance is out of range. | Reposition your front speakers. ^{c)} |
| WARN. 62 | The center speaker level is out of range. | Reposition your center speaker. ^{d)} |
| WARN. 63 | The surround left speaker level is out of range. | Reposition your surround left speaker. ^{e)} |
| WARN. 64 | The surround right speaker level is out of range. | Reposition your surround right speaker. ^{f)} |
| WARN. 70 | The front speaker distance is out of range. | Reposition your front speakers. ^{c)} |
| WARN. 72 | The center speaker distance is out of range. | Reposition your center speaker. ^{d)} |
| WARN. 73 | The surround left speaker distance is out of range. | Reposition your surround left speaker. ^{e)} |
| WARN. 74 | The surround right speaker distance is out of range. | Reposition your surround right speaker. ^{f)} |

^{c)} For details, refer “Front speaker distance” (page 45).

^{d)} For details, refer “Center speaker distance” (page 45).

^{e)} For details, refer “Surround left speaker distance” (page 45).

^{f)} For details, refer “Surround right speaker distance” (page 45).

8: Adjusting the speaker levels and balance (TEST TONE)

You can adjust the speaker levels and balance while listening to the test tone from your listening position.

Tip

The receiver employs a test tone with a frequency centered at 800 Hz.

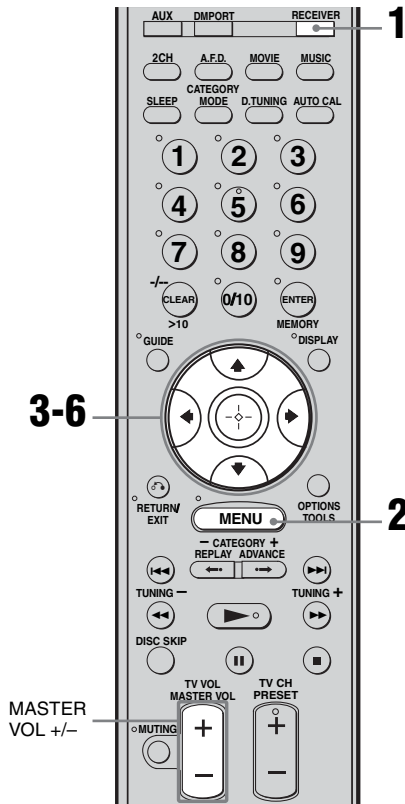

- 3** Press \oplus or \rightarrow to enter the menu.
- 4** Press \uparrow/\downarrow repeatedly to select “T. TONE”.
- 5** Press \oplus or \rightarrow to enter the parameter.
- 6** Press \uparrow/\downarrow repeatedly to select “T. TONE Y”.

The test tone is output from each speaker in sequence as follows:

Front left \rightarrow Center \rightarrow Front right \rightarrow
Surround right \rightarrow Surround left \rightarrow
Sub woofer

- 7** Adjust the speaker levels and balance using the LEVEL menu so that the level of the test tone sounds the same from each speaker.

For details, see “Adjusting the level (LEVEL menu)” (page 41).

Tips

- To adjust the level of all speakers at the same time, press MASTER VOL +/- . You can also use MASTER VOLUME on the receiver.
- The adjusted value are shown on the display during adjustment.

- 8** Repeat steps 1 to 6 to select “T. TONE N”.

You can also press any input buttons. The test tone turns off.

- 1** Press RECEIVER.

The RECEIVER indicator lights up and receiver operation is activated.

- 2** Press MENU.

“1-LEVEL” appears on the display.

Selecting a component



1 Press the input button to select a component.

You can also use INPUT SELECTOR on the receiver.

The selected input appears on the display.

| Selected input [Display] | Components that can be played back |
|--------------------------------|--|
| VIDEO 1 [VIDEO 1] | VCR, etc., connected to the VIDEO 1 jack |
| VIDEO 2 [VIDEO 2/BD]* | Blu-ray disc player, etc., connected to the VIDEO 2/BD jack |
| VIDEO 3 [VIDEO 3/PORTABLE AV]* | Camcorder, video game, etc., connected to the VIDEO 3 IN/PORTABLE AV IN jack |
| DVD [DVD] | DVD player, etc., connected to DVD jack |
| SAT [SAT] | Satellite tuner, set-top box, etc., connected to SAT jack |
| TV [TV] | TV, etc., connected to TV jack |
| SA-CD/CD [SA-CD/CD/CD-R]* | Super Audio CD player, CD player, etc., connected to the SA-CD/CD/CD-R jack |
| TUNER [FM or AM band] | Built-in radio tuner |
| TUNER [XM RADIO] | For details, see page 56. |
| DMPORT [DMPORT] | DIGITAL MEDIA PORT adapter connected to DMPORT jack |

* "VIDEO 2/BD", "VIDEO 3/PORTABLE AV" and "SA-CD/CD/CD-R" scroll across the display, then "VIDEO 2", "VIDEO 3" and "SA-CD/CD" appear respectively.

2 Turn on the component and start playback.

3 Press MASTER VOL +/- to adjust the volume.

You can also use MASTER VOLUME on the receiver.

To mute the sound

Press MUTING.

The muting function will be canceled when you do the following.

- Press MUTING again.
- Increase the volume.
- Turn off the receiver.

To avoid damaging your speakers

Before you turn off the receiver, be sure to turn down the volume level.

To listen to the sub woofer

Be sure to use the buttons on the rear panel of the sub woofer for this operation.

1 Press POWER.

The POWER indicator lights up.

2 Turn LEVEL to adjust the volume.

Set the volume level to suit your preference according to the selected input as slight adjustments may enhance the sound.

Note

Do not set the volume of the sub woofer to maximum as extraneous noise may be heard.

Listening/Watching a component

Listening to a Super Audio CD/CD

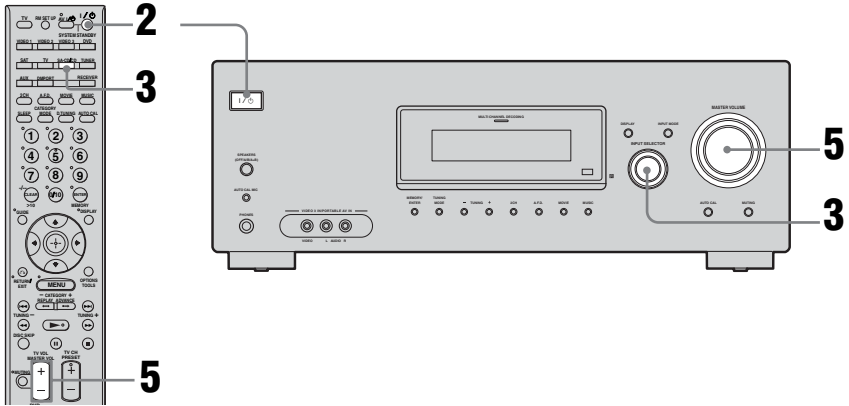

Notes

- The operation is described for a Sony Super Audio CD player.
- Refer to the operating instructions supplied with the Super Audio CD player or CD player.

Tips

- You can select the sound field to suit the music. Refer to page 49 for details.
Recommended sound fields:
Classical: HALL
Jazz: JAZZ
Live concert: CONCERT
- You can listen to the sound that was recorded in the 2 channel format from all speakers (multi channel). Refer to page 47 for details.

1 Turn on the Super Audio CD player/CD player, then place the disc on the tray.

2 Turn on the receiver.

3 Press SA-CD/CD.

You can also use INPUT SELECTOR on the receiver to select "SA-CD/CD/CD-R".

4 Playback the disc.

5 Adjust to a suitable volume.

6 After you have finished listening to the Super Audio CD/CD, eject the disc and turn off the receiver and Super Audio CD player/CD player.

Watching a DVD

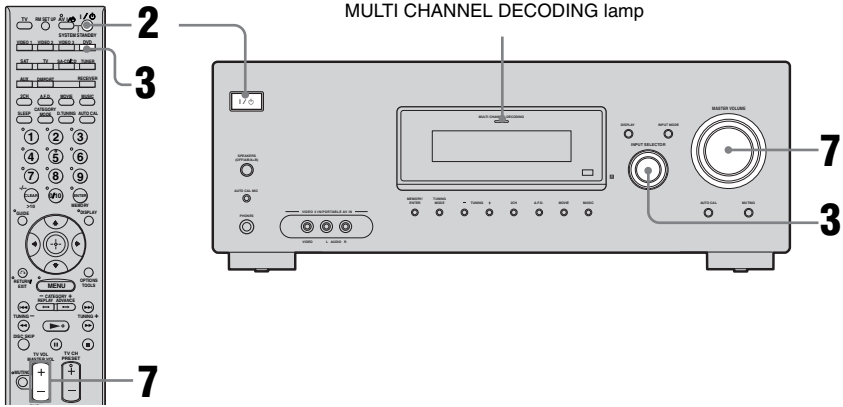

Notes

- Refer to the operating instructions supplied with the TV and DVD player.
- Check the following if you cannot listen to multi channel sound.
 - Be sure the sound source corresponds to the multi channel format (the MULTI CHANNEL DECODING lamp on the front panel lights up during playback).
 - Be sure this receiver is connected to the DVD player via a digital connection.
 - Be sure the digital audio output of the DVD player is set up properly.

Tips

- Select the sound format of the disc to be played, if necessary.
- You can select the sound field to suit the movie/music. Refer to page 49 for details.
Recommended sound fields:
Movie: C.ST.EX
Music: CONCERT

1 Turn on the TV and DVD player.

2 Turn on the receiver.

3 Press DVD.

You can also use INPUT SELECTOR on this receiver to select “DVD”.

4 Switch the input of the TV so that an image of the DVD is displayed.

5 Set up the DVD player.

Refer to the “Quick Setup Guide” supplied with the receiver.

6 Playback the disc.

7 Adjust to a suitable volume.

8 After you have finished watching the DVD, eject the disc and turn off the receiver, TV and DVD player.

Amplifier Operations

Navigating through menus

By using the amplifier menus, you can make various adjustments to customize the receiver.

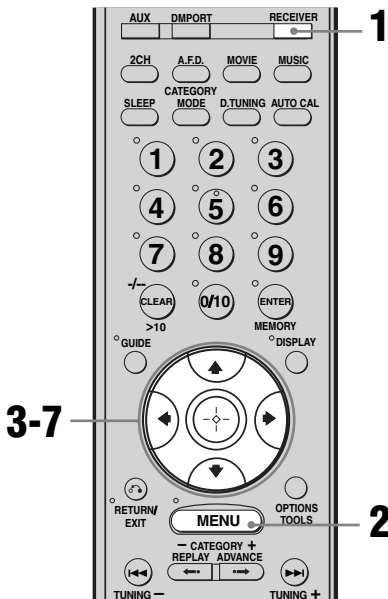

1 Press RECEIVER.

The RECEIVER indicator lights up and receiver operation is activated.

2 Press MENU.

“1-LEVEL” appears on the display.

3 Press \uparrow/\downarrow repeatedly to select the menu you want.

4 Press \ominus or \rightarrow to enter the menu.

5 Press \uparrow/\downarrow repeatedly to select the parameter you want to adjust.

6 Press \ominus or \rightarrow to enter the parameter.

7 Press \uparrow/\downarrow repeatedly to select the setting you want.

The setting is entered automatically.

8 Repeat steps 3 to 7 when you want to make other settings.

To return to the previous display

Press \leftarrow .

To exit the menu

Press MENU.

However, if the RECEIVER button is light-off, press RECEIVER and then press MENU.

Note

Some parameters and settings may appear dimmed on the display. This means that they are either unavailable or fixed and unchangeable.

Overview of the menus

The following options are available in each menu. For details on navigating through menus, see page 38.

| Menu [Display] | Parameters [Display] | Settings | Initial setting |
|-------------------------|---|---|-----------------|
| LEVEL (41) [1-LEVEL] | Test tone ^{a)} [T. TONE] | T. TONE Y, T. TONE N | T. TONE N |
| | Front speaker balance ^{a)} [FRT BAL] | BAL. L +1 to BAL. L +8, BALANCE, BAL. R +1 to BAL. R +8 | BALANCE |
| | Center speaker level [CNT LVL] | CNT -10 dB to CNT +10 dB (1 dB step) | CNT 0 dB |
| | Surround left speaker level [SL LVL] | SUR L -10 dB to SUR L +10 dB (1 dB step) | SUR L 0 dB |
| | Surround right speaker level [SR LVL] | SUR R -10 dB to SUR R +10 dB (1 dB step) | SUR R 0 dB |
| | Sub woofer level [SW LVL] | SW -10 dB to SW +10 dB (1 dB step) | SW 0 dB |
| | Dynamic range compressor ^{a)} [D. RANGE] | COMP. OFF, COMP. STD, COMP. MAX | COMP. OFF |
| TONE (42) [2-TONE] | Front speaker bass level [BASS LVL] | BASS -6 dB to BASS +6 dB (1 dB step) | BASS 0 dB |
| | Front speaker treble level [TRE LVL] | TRE -6 dB to TRE +6 dB (1 dB step) | TRE 0 dB |
| SUR (42) [3-SUR] | Sound field selection ^{a)} [S.F. SELECT] | 2CH ST., A.F.D. AUTO, DOLBY PL, PLII MV, PLII MS, MULTI ST., C.ST.EX A, C.ST.EX B, C.ST.EX C, PORTABLE, HALL, JAZZ, CONCERT | A.F.D. AUTO |
| | Effect level ^{a)} ^{b)} [EFFECT] | EFCT. MIN, EFCT. STD, EFCT. MAX | EFCT. STD |
| TUNER (43) [4-TUNER] | FM station receiving mode ^{a)} [FM MODE] | FM AUTO, FM MONO | FM AUTO |
| | Naming preset stations ^{a)} [NAME IN] | | |

| Menu [Display] | Parameters [Display] | Settings | Initial setting |
|---------------------------|--|--|---|
| AUDIO (43) [5-AUDIO] | Digital audio input decoding priority ^{a)} [DEC. PRI.] | DEC. AUTO, DEC. PCM | DEC. AUTO for: VIDEO 1, 2, 3, TV, SAT, DVD; DEC. PCM for: SA-CD/CD/ CD-R |
| | Digital broadcast language selection ^{a)} [DUAL] | DUAL M/S, DUAL M, DUAL S, DUAL M+S | DUAL M |
| | Synchronizes audio with video output ^{a)} [A.V. SYNC.] | A.V.SYNC. Y, A.V.SYNC. N | A.V.SYNC. N |
| | Digital Assign [D.ASSIGN] | VD2-VD1, VD2-VD2, VD2-VD3, VD2-DVD, VD2-TV, VD2-CD, DVD-VD1, DVD-VD2, DVD-VD3, DVD-DVD, DVD-TV, DVD-CD, SAT-VD1, SAT-VD3, SAT-DVD, SAT-SAT, SAT-TV, SAT-CD | VD2-VD2 for: VIDEO 2; DVD-DVD for: DVD; SAT-SAT for: SAT |
| | Naming inputs ^{a)} [NAME IN] | | |
| VIDEO (44) [6-VIDEO] | DIGITAL MEDIA PORT video assign ^{a)} [DMPORT V.] | -NONE, -VIDEO 1, -VIDEO 3, -DVD, -SAT | -NONE |
| | Naming inputs ^{a)} [NAME IN] | | |
| SYSTEM (45) [7-SYSTEM] | Front speaker distance ^{a)} [FRT DIST.] | DIST. 3 ft. to DIST. 23 ft. (1 ft. step) | DIST. 10 ft |
| | Center speaker distance ^{a)} [CNT DIST.] | DIST. ■■ ft. between front speaker distance and 5 ft. (1 ft. step) | DIST. 10 ft |
| | Surround left speaker distance ^{a)} [SL DIST.] | DIST. ■■ ft. between front speaker distance and 15 ft. (1 ft. step) | DIST. 10 ft |
| | Surround right speaker distance ^{a)} [SR DIST.] | DIST. ■■ ft. between front speaker distance and 15 ft. (1 ft. step) | DIST. 10 ft |
| | Surround speaker position ^{a)} [SUR POS.] | SIDE/LO, SIDE/HI, BEHD/LO, BEHD/HI | SIDE/LO |
| | Brightness of the display ^{a)} [DIMMER] | 0% dim, 40% dim, 70% dim | 0% dim |
| A. CAL (47) [8-A. CAL] | Auto Calibration ^{a)} [AUTO CAL] | A.CAL YES, A.CAL NO | A.CAL NO |

^{a)}For details, refer to the page in the parentheses.

^{b)}The surround effect is not available for "PORTABLE" sound field.

Adjusting the level

(LEVEL menu)

You can use the LEVEL menu to adjust the balance and level of each speaker. These settings are applied to all sound fields. Select “1-LEVEL” in the amplifier menus. For details on adjusting the parameters, see “Navigating through menus” (page 38) and “Overview of the menus” (page 39).

LEVEL menu parameters

■ T. TONE (Test tone)

Lets you adjust the speaker levels and balance while listening to the test tone from your listening position. For details, see “8: Adjusting the speaker levels and balance (TEST TONE)” (page 33).

■ FRT BAL (Front speaker balance)

Lets you adjust the balance between front left and right speakers.

■ CNT LVL (Center speaker level)

■ SL LVL (Surround left speaker level)

■ SR LVL (Surround right speaker level)

■ SW LVL (Sub woofer level)

■ D. RANGE (Dynamic range compressor)

Lets you compress the dynamic range of the sound track. This may be useful when you want to watch movies at low volumes late at night. Dynamic range compression is possible with Dolby Digital sources only.

- COMP. OFF
The dynamic range is not compressed.
- COMP. STD
The dynamic range is compressed as intended by the recording engineer.
- COMP. MAX
The dynamic range is compressed dramatically.

Tip

Dynamic range compressor lets you compress the dynamic range of the soundtrack based on the dynamic range information included in the Dolby Digital signal.

“COMP. STD” is the standard setting, but it only enacts light compression. Therefore, we recommend using the “COMP. MAX” setting. This greatly compresses the dynamic range and lets you view movies late at night at low volumes. Unlike analog limiters, the levels are predetermined and provide a very natural compression.

Adjusting the tone (TONE menu)

You can use the TONE menu to adjust the tonal quality (bass/treble level) of the front speakers.

Select “2-TONE” in the amplifier menus. For details on adjusting the parameters, see “Navigating through menus” (page 38) and “Overview of the menus” (page 39).

TONE menu parameters

- **BASS LVL (Front speaker bass level)**
- **TRE LVL (Front speaker treble level)**

Settings for the surround sound (SUR menu)

You can use the SUR menu to select the sound field you want for your listening pleasure.

Select “3-SUR” in the amplifier menus. For details on adjusting the parameters, see “Navigating through menus” (page 38) and “Overview of the menus” (page 39).

SUR menu parameters

■ S.F. SELCT (Sound field selection)

Lets you select the sound field you want. For details, see “Enjoying Surround Sound” (page 47).

Note

The receiver lets you apply the last selected sound field to an input whenever it is selected (Sound Field Link). For example, if you select “HALL” for the SA-CD/CD input, then change to a different input and then return to SA-CD/CD, “HALL” will automatically be applied again.

■ EFFECT (Effect level)

Lets you adjust the “presence” of the surround effect for sound fields selected with the MOVIE or MUSIC buttons and for “HP THEA” sound field. However, the surround effect is not available for “PORTABLE” sound field.

- EFCT. MIN
The surround effect is minimum.
- EFCT. STD
The surround effect is standard.
- EFCT. MAX
The surround effect is maximum.

Settings for the tuner

(TUNER menu)

You can use the TUNER menu to set the FM station receiving mode and to name preset stations.

Select “4-TUNER” in the amplifier menus. For details on adjusting the parameters, see “Navigating through menus” (page 38) and “Overview of the menus” (page 39).

TUNER menu parameters

■ FM MODE (FM station receiving mode)

- FM AUTO
This receiver will decode the signal as stereo signal when the radio station is broadcast in stereo.
- FM MONO
This receiver will decode the signal as mono signal regardless of the broadcast signal.

■ NAME IN (Naming preset stations)

Lets you set the name of preset stations. For details, see “Naming preset stations” (page 55).

Settings for the audio

(AUDIO menu)

You can use the AUDIO menu to make settings for the audio to suit your preference. Select “5-AUDIO” in the amplifier menus. For details on adjusting the parameters, see “Navigating through menus” (page 38) and “Overview of the menus” (page 39).

AUDIO menu parameters

■ DEC. PRI. (Digital audio input decoding priority)

Lets you specify the input mode for the digital signal input to the DIGITAL IN jacks.

- DEC. AUTO
Automatically switches the input mode between DTS, Dolby Digital, or PCM.
- DEC. PCM
PCM signals are given priority (to prevent interruption when playback starts). However, when other signals are input, there may be no sound depending on the format. In this case, set to “DEC. AUTO”.

Note

When set to “DEC. AUTO” and the sound from the digital audio jacks (for CD, etc.) is interrupted when playback starts, set to “DEC. PCM”.

■ DUAL (Digital broadcast language selection)

Lets you select the language you want to listen to during digital broadcast. This feature only functions for Dolby Digital sources.

- DUAL M/S (Main/Sub)
Sound of the main language will be output through the front left speaker and sound of the sub language will be output through the front right speaker simultaneously.
- DUAL M (Main)
Sound of the main language will be output.
- DUAL S (Sub)
Sound of the sub language will be output.
- DUAL M+S (Main + Sub)
Mixed sound of both the main and sub languages will be output.

■ A.V. SYNC. (Synchronizes audio with video output)

- A.V.SYNC. Y (Yes) (Delay time: 68 ms)
The audio output is delayed so that the time gap between the audio output and visual display is minimized.
- A.V.SYNC. N (No) (Delay time: 0 ms)
The audio output is not delayed.

Notes

- This parameter is useful when you use a large LCD or plasma monitor or a projector.
- This parameter is valid only when you use a sound field selected with the 2CH or A.F.D. buttons.

■ D.ASSIGN (Digital audio input assignment)

Lets you assign the digital audio input to other input source. For details, see “Listening to digital sound from other inputs (DIGITAL ASSIGN)” (page 66).

■ NAME IN (Naming inputs)

Lets you set the name of inputs. For details, see “Naming inputs” (page 67).

Settings for the video (VIDEO menu)

You can use the VIDEO menu to assign the composite video input to DMPORT input and to name inputs.

Select “6-VIDEO” in the amplifier menus. For details on adjusting the parameters, see “Navigating through menus” (page 38) and “Overview of the menus” (page 39).

VIDEO menu parameters

■ DMPORT V. (DIGITAL MEDIA PORT video assign)

Lets you assign the composite video input to DMPORT input so that you can view the images on the TV screen. For details, see “Watching a connected component through DMPORT connection” (page 65).

■ NAME IN (Naming inputs)

Lets you set the name of inputs. For details, see “Naming inputs” (page 67).

Settings for the system (SYSTEM menu)

You can use the SYSTEM menu to set the size and distance of the speakers connected to this system.

Select “7-SYSTEM” in the amplifier menus. For details on adjusting the parameters, see “Navigating through menus” (page 38) and “Overview of the menus” (page 39).

SYSTEM menu parameters

■ FRT DIST. (Front speaker distance)

Lets you set the distance from your listening position to the front speaker (A). If both front speakers are not placed an equal distance from your listening position, set the distance as the average distance between the front speakers.

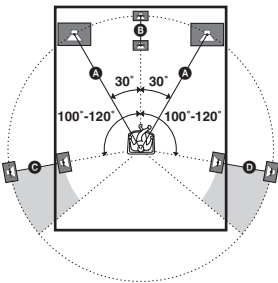

■ CNT DIST. (Center speaker distance)

Lets you set the distance from your listening position to the center speaker. Center speaker distance should be set from a distance equal to the front speaker distance (A) to a distance 5 feet closer to your listening position (B).

■ SL DIST. (Surround left speaker distance)

Lets you set the distance from your listening position to the surround left speaker. Surround left speaker distance should be set from a distance equal to the front speaker distance (A) to a distance 15 feet closer to your listening position (C).

■ SR DIST. (Surround right speaker distance)

Lets you set the distance from your listening position to the surround right speaker. Surround right speaker distance should be set from a distance equal to the front speaker distance (A) to a distance 15 feet closer to your listening position (D).

Tip

The receiver lets you to input the speaker position in terms of distance. However, it is not possible to set the center speaker further than the front speakers. Also, the center speaker cannot be set more than 5 feet closer from the front speakers. Likewise, the surround speakers can not be set further away from the listening position than the front speakers. And they can be no more than 15 feet closer. This is because incorrect speaker placement is not conducive to the enjoyment of surround sound.

Please note that, setting the speaker distance closer than the actual location of the speakers will cause a delay in the output of the sound from that speaker. In other words, the speaker will sound like it is further away.

For example, setting the center speaker distance 3-6 feet closer than the actual speaker position will create a fairly realistic sensation of being “inside” the screen. If you cannot obtain a satisfactory surround effect because the surround speakers are too close, setting the surround speaker distance closer (shorter) than the actual distance will create a larger sound stage.

Adjusting these parameter while listening to the sound often results in much better surround sound. Give it a try!

■ SUR POS. (Surround speaker position)

Lets you specify the location of your surround speakers for proper implementation of the surround effects in the Cinema Studio EX modes (page 50).

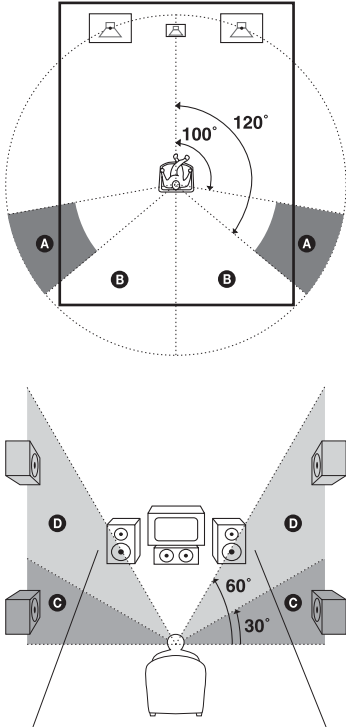

- **SIDE/LO**
Select if the location of your surround speakers corresponds to sections **A** and **C**.
- **SIDE/HI**
Select if the location of your surround speakers corresponds to sections **A** and **D**.
- **BEHD/LO**
Select if the location of your surround speakers corresponds to sections **B** and **C**.
- **BEHD/HI**
Select if the location of your surround speakers corresponds to sections **B** and **D**.

Tip

Surround speaker position is designed specifically for implementation of the Cinema Studio EX modes. For other sound fields, speaker position is not so critical.

Those sound fields were designed under the premise that the surround speakers would be located behind the listening position, but presentation remains fairly consistent even with the surround speakers positioned at a rather wide angle. However, if the speakers are pointing toward the listener from the immediate left and right of the listening position, the surround effects become unclear unless set to “SIDE/LO” or “SIDE/HI”.

Nevertheless, each listening environment has many variables, such as wall reflections, and you may obtain better results using “BEHD/HI” if your speakers are located high above the listening position, even if they are located to the immediate left and right.

Therefore, although it may result in a setting contrary to the above explanation, we recommend that you playback multi channel surround encoded software and select the setting that provides a good sense of spaciousness and that best succeeds in forming a cohesive space between the surround sound from the surround speakers and the sound of the front speakers. If you are not sure which sounds best, select “BEHD/LO” or “BEHD/HI” and then use the speaker distance parameter and speaker level adjustments to obtain proper balance.

■ DIMMER (Brightness of the display)

Lets you adjust the brightness in 3 steps.

Calibrating the appropriate settings automatically

(A. CAL menu)

For details, see “7: Calibrating the appropriate settings automatically (AUTO CALIBRATION)” (page 29).

Enjoying Surround Sound

Enjoying Dolby Digital and DTS Surround sound (AUTO FORMAT DIRECT)

The Auto Format Direct (A.F.D.) mode allows you to listen to higher fidelity sound and select the decoding mode for listening to a 2 channel stereo sound as multi channel sound.

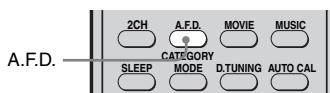

Press A.F.D. repeatedly to select the sound field you want.

For details, see “Types of A.F.D. mode” (page 48).

Types of A.F.D. mode

| Decoding mode | A.F.D. mode [Display] | Multi channel audio after decoding | Effect |
|---------------------------|---------------------------------|---|---|
| (Detecting automatically) | A.F.D. AUTO [A.F.D. AUTO] | (Detecting automatically) | Presents the sound as it was recorded/ encoded without adding any surround effects. However, this receiver will generate a low frequency signal for output to the sub woofer when there is no LFE signals. |
| Dolby Pro Logic | PRO LOGIC [DOLBY PL] | 4 channel | Performs Dolby Pro Logic decoding. The source recorded in 2 channel format is decoded into 4,1 channels. |
| Dolby Pro Logic II | PRO LOGIC II MOVIE [PLII MV] | 5 channel | Performs Dolby Pro Logic II Movie mode decoding. This setting is ideal for movies encoded in Dolby Surround. In addition, this mode can reproduce sound in 5.1 channel for watching videos of overdubbed or old movies. |
| | PRO LOGIC II MUSIC [PLII MS] | 5 channel | Performs Dolby Pro Logic II Music mode decoding. This setting is ideal for normal stereo sources such as CDs. |
| (Multi Stereo) | MULTI STEREO [MULTI ST.] | (Multi Stereo) | Outputs 2 channel left/right signals from all speakers. |

Selecting a pre-programmed sound field

You can take advantage of surround sound simply by selecting one of the receiver's pre-programmed sound fields. They bring the exciting and powerful sound of movie theaters and concert halls into your home.

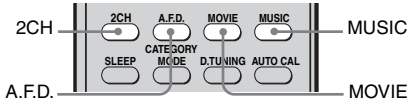

Press MOVIE repeatedly to select a sound field for movies or press MUSIC repeatedly to select a sound field for music.

For details, see “Types of sound field available” (page 50).

Types of sound field available

| Sound field for | Sound field [Display] | Effect |
|-----------------|--|--|
| Movie | CINEMA STUDIO EX A DCS [C.ST.EX A] | Reproduces the sound characteristics of the Sony Pictures Entertainment "Cary Grant Theater" cinema production studio. This is a standard mode, great for watching almost any type of movie. |
| | CINEMA STUDIO EX B DCS [C.ST.EX B] | Reproduces the sound characteristics of the Sony Pictures Entertainment "Kim Novak Theater" cinema production studio. This mode is ideal for watching science-fiction or action movies with lots of sound effects. |
| | CINEMA STUDIO EX C DCS [C.ST.EX C] | Reproduces the sound characteristics of the Sony Pictures Entertainment scoring stage. This mode is ideal for watching musicals or films where orchestra music is featured in the soundtrack. |
| Music | PORTABLE AUDIO [PORTABLE] | Reproduces a clear enhanced sound image from your portable audio device. This mode is ideal for MP3 and other compressed music. |
| | HALL [HALL] | Reproduces the acoustics of a classical concert hall. |
| | JAZZ CLUB [JAZZ] | Reproduces the acoustics of a jazz club. |
| | LIVE CONCERT [CONCERT] | Reproduces the acoustics of a 300-seat live house. |
| Headphone | HEADPHONE 2CH [HP 2CH] | This mode is selected automatically if you use headphone when 2 channel mode (page 51)/A.F.D. mode (page 48) is selected. Standard 2 channel stereo sources completely bypass the sound field processing and multi channel surround formats are downmixed to 2 channels. |
| | HEADPHONE THEATER DCS [HP THEA] | This mode is selected automatically if you use headphone when sound field for movie/music is selected. It allows you to experience a theater-like environment while listening through a pair of headphones. |

About DCS (Digital Cinema Sound)

Sound fields with **DCS** mark use DCS technology.

DCS is a unique sound reproduction technology for home theater developed by Sony, in cooperation with Sony Pictures Entertainment, for enjoying the exciting and powerful sound of movie theaters at home. With this "Digital Cinema Sound" developed by integrating a DSP (Digital signal processor) and measured data, the ideal sound field intended by film makers can be experienced at home.

About CINEMA STUDIO EX modes

CINEMA STUDIO EX modes are suitable for watching motion picture DVDs (etc.), with multi channel surround effects. You can reproduce the sound characteristics of Sony Pictures Entertainment's dubbing studio in your home.

The CINEMA STUDIO EX modes consist of the following three elements.

- Virtual Multi Dimension
Creates 5 sets of virtual speakers from a single pair of actual surround speakers.
- Screen Depth Matching
Creates the sensation that the sound is coming from inside the screen like in theaters.
- Cinema Studio Reverberation
Reproduces the type of reverberation found in theaters.





The CINEMA STUDIO EX modes integrate these three elements simultaneously.

Notes

- The effects provided by the virtual speakers may cause increased noise in the playback signal.
- When listening with sound fields that employ the virtual speakers, you will not be able to hear any sound coming directly from the surround speakers.
- This function does not work for signals with a sampling frequency of more than 48 kHz.

Tip

You can identify the encoding format of DVD software, etc., by looking at the logo on the package.

-  : Dolby Digital discs
-   : Dolby Surround encoded programs
-  : DTS Digital Surround encoded programs

To turn off the surround effect for movie/music

Press 2CH to select "2CH ST." or press A.F.D. repeatedly to select "A.F.D. AUTO".

Using only the front speakers and sub woofer (2CH STEREO)

In this mode, the receiver outputs the sound from the front left/right speakers and the sub woofer.

When multi channel surround formats are input, the signals are downmixed to 2 channel with bass frequencies being output from the sub woofer.

When standard 2 channel stereo sources are input, the receiver's bass redirection circuitry will be activated. The front channel bass frequencies will be output from the sub woofer.

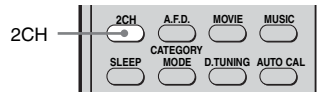

Press 2CH.

Resetting sound fields to the initial settings

Be sure to use the buttons on the receiver for this operation.

1,2

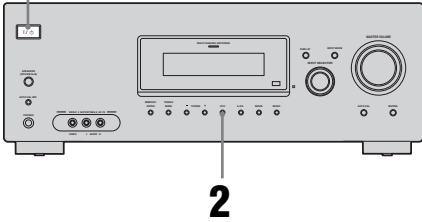

1 Press I/O to turn off the receiver.

2 While holding down 2CH, press I/O.

“S.F. CLR.” appears on the display and all sound fields are reset to their initial setting.

Tuner Operations

Listening to FM/AM radio

You can listen to FM and AM broadcasts through the built-in tuner. Before operation, make sure you have connected the FM and AM antennas to the receiver (page 26).

Tip

The tuning scale is:

FM : 100 kHz

AM : 10 kHz*

* The AM tuning scale can be changed (page 81).

Automatic tuning

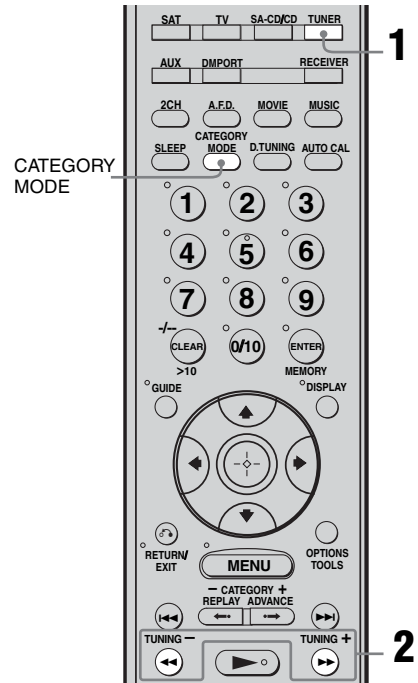

- 1 Press TUNER repeatedly to select the FM or AM band.**
- 2 Press TUNING + or TUNING –.**

Press TUNING + to scan from low to high; press TUNING – to scan from high to low.

The receiver stops scanning whenever a station is received.

Using the controls on the receiver

- Turn INPUT SELECTOR to select the FM or AM band.
- Press TUNING MODE repeatedly to select “AUTO T.”.
- Press TUNING + or TUNING –.

In case of poor FM stereo reception

If the FM stereo reception is poor and “ST” flashes on the display, select monaural audio so that the sound will be less distorted.

- To select monaural audio, you can
 - press FM MODE repeatedly until the “MONO” indicator lights up on the display.
 - set “FM MODE” in TUNER menu to “FM MONO” (page 39).
- To return to stereo mode, you can
 - press FM MODE repeatedly until the “MONO” indicator on the display do not light up.
 - set “FM MODE” in TUNER menu to “FM AUTO” (page 39).

Direct tuning

Enter the frequency of a station directly by using the numeric buttons.

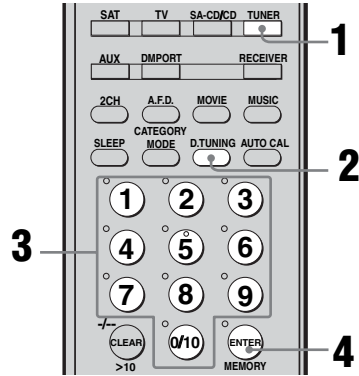

- 1 Press TUNER repeatedly to select the FM or AM band.**
You can also use INPUT SELECTOR on the receiver.
- 2 Press D.TUNING.**
- 3 Press the numeric buttons to enter the frequency.**
Example 1: FM 102.50 MHz
Select 1 → 0 → 2 → 5 → 0
Example 2: AM 1,350 kHz
Select 1 → 3 → 5 → 0
- 4 Press ENTER.**
You can also use MEMORY/ENTER on the receiver.

Tip

If you have tuned in an AM station, adjust the direction of the AM loop antenna for optimum reception.

If you cannot tune in a station

Make sure you have entered the right frequency. If not, repeat steps 2 to 4. If you still cannot tune in a station, the frequency is not used in your area.

Presetting radio stations

You can preset up to 30 FM stations and 30 AM stations. Then you can easily tune in the stations you often listen to.

Presetting radio stations

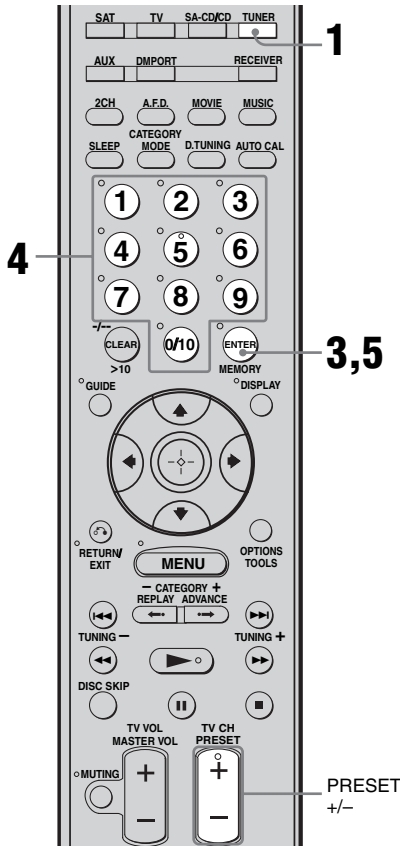

1 Press TUNER repeatedly to select the FM or AM band.

You can also use INPUT SELECTOR on the receiver.

2 Tune in the station that you want to preset using Automatic Tuning (page 52) or Direct Tuning (page 53).

Switch the FM reception mode, if necessary (page 53).

3 Press MEMORY.

You can also use MEMORY/ENTER on the receiver.

“MEMORY” lights up for a few seconds. Perform steps 4 and 5 before “MEMORY” goes out.

4 Press the numeric buttons to select a preset number.

You can also press PRESET + or PRESET - to select a preset number. If “MEMORY” goes out before you select the preset number, start again from step 3.

5 Press ENTER.

You can also use MEMORY/ENTER on the receiver.

The station is stored as the selected preset number.

If “MEMORY” goes out before you press ENTER, start again from step 3.

6 Repeat steps 1 to 5 to preset another station.

Tuning to preset stations

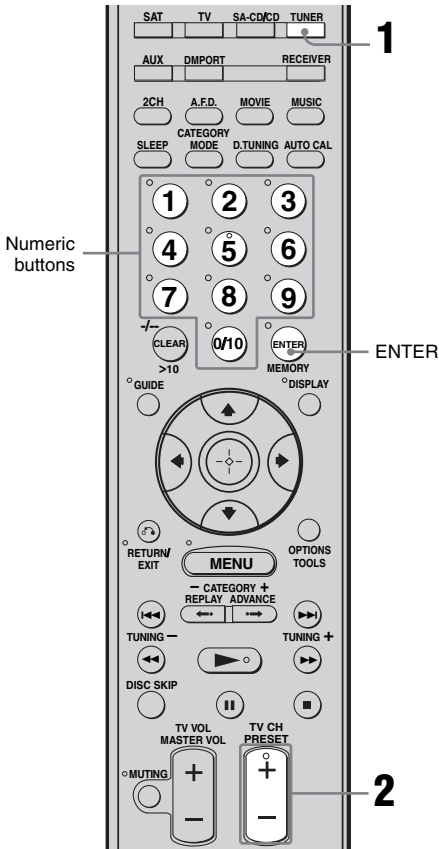

- 1 Press TUNER repeatedly to select the FM or AM band.
- 2 Press PRESET + or PRESET – repeatedly to select the preset station you want.

Each time you press the button, you can select a preset station as follows:

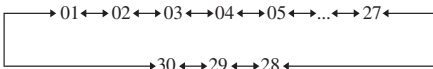

You can also press the numeric buttons to select the preset station you want. Then, press ENTER to enter the selection.

Using the controls on the receiver

- 1 Turn INPUT SELECTOR to select the FM or AM band.
- 2 Press TUNING MODE repeatedly to select “PRESET T.”.
- 3 Press TUNING + or TUNING – repeatedly to select the preset station you want.

Naming preset stations



- 1 Press TUNER repeatedly to select the FM or AM band. You can also use INPUT SELECTOR on the receiver.
- 2 Tune in the preset station you want to create an index name for (page 55).

3 Press RECEIVER.

The RECEIVER indicator is lights up and receiver operation is activated.

4 Press MENU.

“1-LEVEL” appears on the display.

5 Press \uparrow/\downarrow repeatedly to select “4-TUNER”.

6 Press \oplus or \rightarrow to enter the menu.

7 Press \uparrow/\downarrow repeatedly to select “NAME IN”.

8 Press \oplus or \rightarrow to enter the parameter.

The cursor flashes and you can select a character. Follow the procedure given in “To create an index name” below.

To create an index name

- 1 Use $\uparrow/\downarrow/\leftarrow/\rightarrow$ to create an index name. Press \uparrow/\downarrow to select a character, then press \leftarrow/\rightarrow to move the cursor to the next position.

If you made a mistake

Press \leftarrow/\rightarrow until the character you want to change flashes, then press \uparrow/\downarrow to select the correct character.

Tip

You can select the character type as follows by pressing \uparrow/\downarrow .
Alphabet (upper case) \rightarrow Numbers \rightarrow Symbols

2 Press \oplus .

The entered name is registered.

Listening to the XM Radio

About XM Satellite Radio

XM Satellite Radio offers an extraordinary variety of commercial-free music, plus the best in sports, news, talk and entertainment. XM is broadcast in superior digital audio from coast to coast. From rock to reggae, from classical to hip hop, XM has something for every music fan. XM’s dedication to playing the richest selection of music is matched by its passion for live sporting events, talk radio, up-to-the-minute news, stand-up comedy, children’s programming, and much more. For U.S. customers, information about XM Satellite Radio is available online at www.xmradio.com. For Canadian customers, information about XM Canada is online at www.xmradio.ca.

XM Satellite Radio Terms and Conditions

Hardware and required monthly subscription sold separately. Other fees and taxes, including a one-time activation fee may apply. Subscription fee is consumer only. All fees and programming subject to change. Channels with frequent explicit language are indicated with an XL. Channel blocking is available for XM radio receivers by calling 1-800-XMRADIO (US residents) and 1-877-GET-XMSR (Canadian residents). For a full listing of the XM commercial-free channels and advertising-supported channels, visit lineup.xmradio.com (US residents) or xmradio.ca (Canadian residents). Subscriptions subject to Customer Agreement available at xmradio.com (US residents) and xmradio.ca (Canadian residents). Only available in the 48 contiguous United States and Canada. ©2006 XM Satellite Radio Inc. All rights reserved. All other trademarks are the property of their respective owners.

To Activate XM Satellite Radio

Once you have installed the XM Mini-Tuner Dock, inserted the XM Mini-Tuner, connected the XM Dock to your XM Ready® home audio system, and installed the antenna, you are ready to subscribe and begin receiving XM programming. There are three places to find your eight character XM Radio ID: on the XM Mini-Tuner, on the XM Mini-Tuner package, and on XM Channel 0. Record the Radio ID in the following eight squares for reference.

□□□□□□□□

Note

The XM radio ID does not use the letters “I”, “O”, “S” or “F”. Activate your XM Satellite Radio service in the U.S. online at <http://activate.xmradio.com> or call 1-800-XM-RADIO (1-800-967-2346). You will need a major credit card. XM will send a signal from the satellites to activate the full channel lineup. Activation normally takes 10 to 15 minutes, but during peak busy periods you may need to keep your XM Ready home audio system on for up to an hour. When you can access the full channel lineup on your XM Ready home audio system you are done. For more information or to subscribe in Canada, visit XM on the Web at www.xmradio.ca or call XM’s Listener Care at 1-877-GET-XMSR (1-877-438-9677).

Connecting the XM Radio

Before operating the system, connect the XM Connect-and-Play antenna to the XM jack.

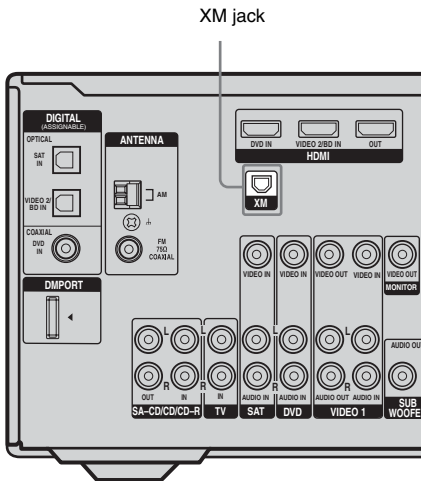

Note

To ensure optional reception of XM’s satellite signal, move your antenna to various window locations around your home to see where the best reception will be received. Most XM customers place the antenna in a south-facing window with a clear view to the sky.

Checking the XM Radio ID



1 Press TUNER repeatedly to select “XM RADIO”.

You can also use INPUT SELECTOR on the receiver.

2 Press TUNING + or TUNING – to select channel 0.

You can also press TUNING MODE on the receiver to select “AUTO T.”, and then press TUNING + or TUNING – to select channel 0.

3 Check the XM Radio ID on the display and write it in the space provided here.

ID: _____

If you cannot read the characters or numbers on the display, refer to the following table.

| Display | Description |
|---------|-------------|
| 2 | 2 (two) |
| 5 | 5 (five) |
| 6 | 6 (six) |
| 8 | 8 (eight) |
| 0 | 0 (zero) |
| A | A |
| B | B |
| D | D |
| G | G |
| H | H |
| K | K |
| M | M |
| Q | Q |
| Z | Z |

Receiving XM Radio broadcasts



1 Press TUNER repeatedly to select the “XM RADIO”.

You can also use INPUT SELECTOR on the receiver.

2 Press TUNING + or TUNING – to select a channel.

You can also press TUNING MODE on the receiver to select “AUTO T.”, and then press TUNING + or TUNING – to select a channel.

Selecting channels from a category (CATEGORY TUNING)

You can select a channel from one category or all the categories by changing the category mode.

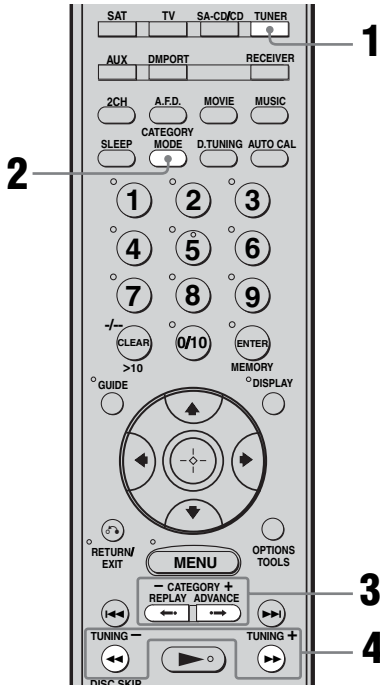

1 Press **TUNER** repeatedly to select the “XM RADIO”.

2 Press **CATEGORY MODE** repeatedly to select “ONE CAT”.

- ALL CAT: You can select a channel from all the categories. The initial setting is “ALL CAT”.
- ONE CAT: You can select a channel from one category. “CAT” is displayed on the display when “ONE CAT” is selected.

3 Press **CATEGORY +** or **CATEGORY –** to select the category you want.

The category is selected and the channel with the lowest number in the specified category is selected.

4 Press **TUNING +** or **TUNING –** to select the channel.

You can also press **TUNING MODE** on the receiver to select “AUTO T.”, and then press **TUNING +** or **TUNING –** to select the channel.

Notes

- When you select a channel in the “ONE CAT” mode, the channel you selected may not be the one in the category you want. This is because one channel may belong to more than one category.
- If you press **CATEGORY +** or **CATEGORY –** in the “ALL CAT” mode, the first channel of the next or previous category is selected (CATEGORY SKIP).

Selecting channels by inputting the channel number directly (DIRECT TUNING)

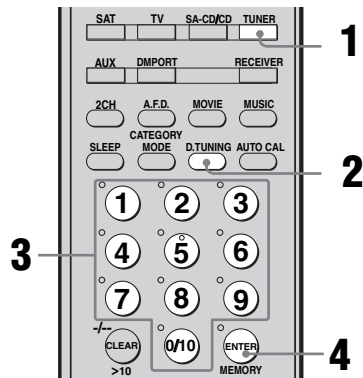

1 Press **TUNER** repeatedly to select the “XM RADIO”.

You can also use **INPUT SELECTOR** on the receiver.

- 2** Press D.TUNING.
- 3** Press the numeric buttons to enter the channel number.
- 4** Press ENTER.

You can also use MEMORY/ENTER on the receiver.

The selected channel is tune in.

Displaying the XM-RADIO information on the front panel display

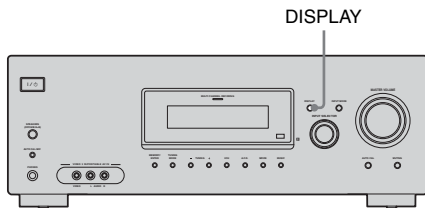

Press DISPLAY on the receiver repeatedly.

Each time you press DISPLAY while tuning in the channel, the display changes cyclically as follows:

Channel name → Channel number →
 Category → Artist name/Feature →
 Song/Program title → Sound field type

Tip

The preset number is always displayed at the right end of the display.

Presetting XM Radio stations

You can select the channels you want directly by presetting them using the preset numbers. You can preset up to 30 XM Radio channels.

Presetting channels using the preset numbers

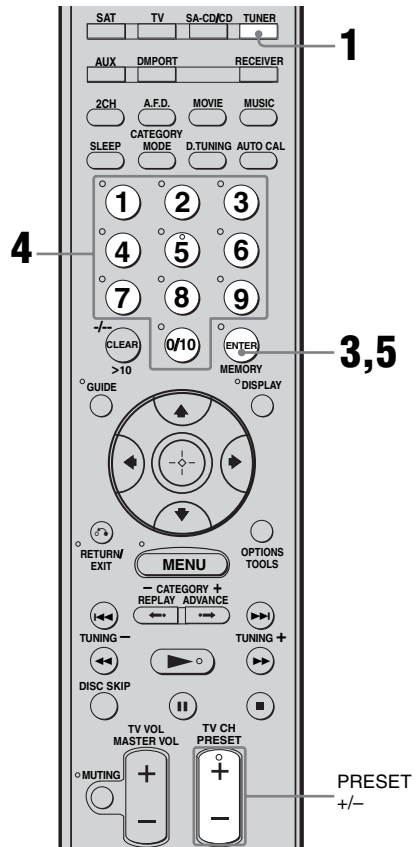

- 1** Press TUNER repeatedly to select the “XM RADIO”.

You can also use INPUT SELECTOR on the receiver.

2 Tune in the channel you want to preset.

For details on selecting channels, see “Listening to the XM Radio” (page 56).

3 Press MEMORY.

You can also use MEMORY/ENTER on the receiver.

4 Press the numeric buttons to enter the preset number.

You can also select the number by pressing PRESET + or PRESET –. You can also press TUNING + or TUNING – on the receiver.

Preset number is available from 1 to 30, and channel 1 is preset for all the preset numbers when you purchase the receiver.

5 Press ENTER.

You can also use MEMORY/ENTER on the receiver.

6 Repeat steps 2 to 5 to preset another channel.

Selecting the channel by using the preset numbers

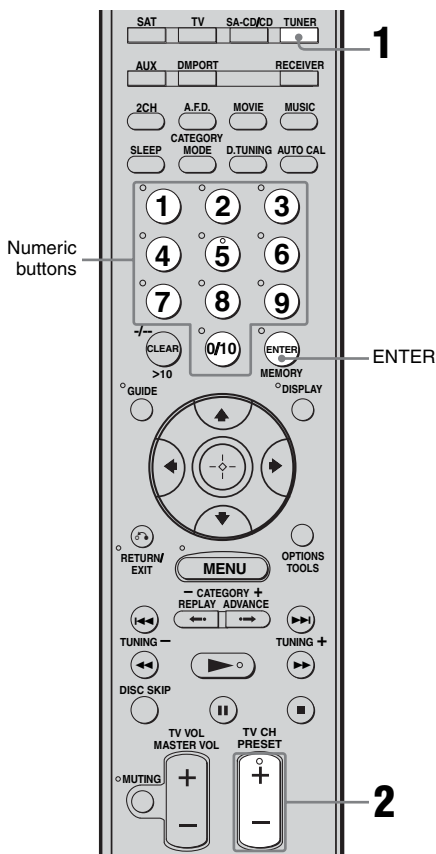

1 Press TUNER repeatedly to select the “XM RADIO”.

2 Press PRESET + or PRESET – repeatedly to select the preset channel you want.

You can also press the numeric buttons to select the preset channel you want. Then press ENTER to enter the selection.

You can also press TUNING MODE on the receiver to select “PRESET T.”, and then press TUNING + or TUNING –.

You can select preset channels from 1 to 30.

continued

Note

The preset channel information will be updated depending on the service provided by the XM Satellite Radio Inc. that you have subscribed to.

XM Radio messages list

| Message appears | Explanation | Remedies |
|------------------------|---|--|
| ANTENNA | The XM antenna is not connected or transmission is not being received properly. | Make sure that the antenna is securely connected. Try to disconnect the antenna then reconnect, or turn off the power then turn back on. |
| UPDATING | The encryption code is being updated. | Wait until the encryption code has been updated. |
| NO SIGNL | The signal is too weak. | Adjust the antenna so that the signal is as strong as possible. |
| LOADING | The audio channel or information is being acquired. | Wait until the audio channel or information has been acquired. |
| OFF AIR | The selected channel is off the air. | Make sure that you selected the channel properly. Try to select another channel. |
| (space)---- | There is no characteristic information such as an artist name, song title or program title available. | — |
| -- | The preset number entered is an invalid number. | Enter a number from 1 to 30. |
| ----CH | The selected channel is not available. | — |

Switching the audio input mode (INPUT MODE)

You can select the audio input mode by setting the audio input mode when you connect components to both digital and analog audio input jacks on the receiver.

1 Turn INPUT SELECTOR on the receiver to select the input.

You can also use the input buttons on the remote.

2 Press INPUT MODE repeatedly on the receiver to select the audio input mode.

The selected audio input mode appears on the display.

Audio input modes

■ AUTO IN

Gives priority to digital audio signals when there are both digital and analog connections. If there are no digital audio signals, analog audio signals are selected.

■ COAX IN

Specifies the digital audio signals input to the DIGITAL COAXIAL jack.

■ OPT IN

Specifies the digital audio signals input to the DIGITAL OPTICAL jack.

■ ANALOG

Specifies the analog audio signals input to the AUDIO IN (L/R) jacks.

Note

Some audio input modes may not be set up depending on the input.

Enjoying the DIGITAL MEDIA PORT (DMPORT)

The DIGITAL MEDIA PORT (DMPORT) allows you to enjoy sound from a network system such as a portable audio source or computer.

By connecting a DIGITAL MEDIA PORT adapter (not supplied), you can enjoy sound from the connected component on the receiver.

For details, see the operating instructions supplied with the DIGITAL MEDIA PORT adapter.

Notes

- Do not connect an adapter other than the DIGITAL MEDIA PORT adapter.
- Do not connect or disconnect the DIGITAL MEDIA PORT adapter while the receiver is turned on.
- Depending on the DIGITAL MEDIA PORT adapter, video output may not be possible.
- The DIGITAL MEDIA PORT adapters are available for purchase depending on the area.

Connecting the DIGITAL MEDIA PORT adapter

You can listen to the sound from the component connected through the DIGITAL MEDIA PORT adapter to the DMPORT jack on the receiver.

You can also view the images on the TV screen by connecting the video output of the DIGITAL MEDIA PORT adapter to the receiver.

To view the images, proceed to “Watching a connected component through DMPORT connection” on page 65.

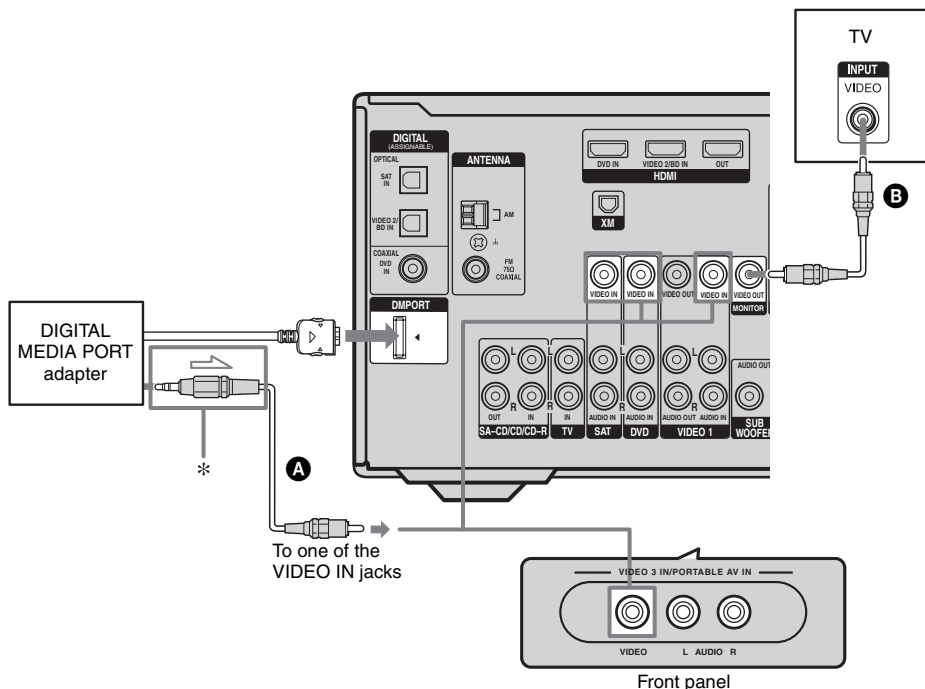

* The type of connector varies depending on the DIGITAL MEDIA PORT adapter. For details, see the operating instructions supplied with the DIGITAL MEDIA PORT adapter.

A Video cord (not supplied)

To detach the DIGITAL MEDIA PORT adapter from DMPORT jack

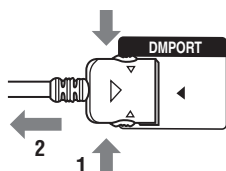

Press and hold both sides of the connector and then pull out the connector.

Notes

- When connecting the DIGITAL MEDIA PORT adapter, be sure the connector is inserted with the arrow mark facing toward the arrow mark on the DMPORT jack.
- Be sure to make DMPORT connections firmly, insert the connector straight in.
- As the connector of the DIGITAL MEDIA PORT adapter is fragile, be sure to handle with care when placing or moving the receiver.

Listening to a connected component through DMPORT connection

1 Press DMPORT.

You can also use the INPUT SELECTOR on the receiver to select “DMPORT”.

2 Start playback of the connected component.

The sound is played back on the receiver. For details, see the operating instructions supplied with the DIGITAL MEDIA PORT adapter.

Watching a connected component through DMPORT connection

You need to assign composite video input to DMPORT input so that you can view the images on the TV screen.

1 Press RECEIVER.

The RECEIVER indicator lights up and receiver operation is activated.

2 Press MENU.

“1-LEVEL” appears on the display.

3 Press \uparrow/\downarrow repeatedly to select “6-VIDEO”.

4 Press \oplus or \rightarrow to enter the menu.

5 Press \uparrow/\downarrow repeatedly to select “DMPORT V.”.

6 Press \ominus or \rightarrow to enter the parameter.

7 Press \uparrow/\downarrow repeatedly to select the composite video input you want to assign to DMPORT input.

Initial setting: –NONE

The assignable composite video input are VIDEO 1, VIDEO 3, DVD and SAT inputs.

For example, select “–VIDEO 1”.

When you press DMPORT, the images from the component connected to the VIDEO 1 VIDEO IN jack through DIGITAL MEDIA PORT adapter will be appear on the TV screen.

To return to the previous display

Press \leftarrow .

Notes

- Depending on the type of DIGITAL MEDIA PORT adapter, you can operate the connected component by using the remote. For details on remote button operation, see page 10.
- Be sure you have made the video connection from DIGITAL MEDIA PORT adapter to the receiver (page 64).
- Be sure you have connected the MONITOR VIDEO OUT of the receiver to the TV (page 19).
- Depending on the DIGITAL MEDIA PORT adapter, video output may not be possible.

Tip

When listening to MP3 or other compressed music using a portable audio source, you can enhance the sound. Press MUSIC repeatedly to select “PORTABLE” (page 49).

Listening to digital sound from other inputs

(DIGITAL ASSIGN)

You can reassign digital audio input that has OPTICAL or COAXIAL (SAT IN, VIDEO 2/BD IN, DVD IN) signals to another input when they are not currently being used. For example, to output the sound source for the DVD player using the OPTICAL IN jack on the receiver:

- Connect the optical output jack of the DVD player to the OPTICAL VIDEO 2/BD IN jack of the receiver.
- Assign “VD2” to “DVD” in the “D.ASSIGN” setting.

1 Press RECEIVER.

The RECEIVER indicator lights up and receiver operation is activated.

2 Press MENU.

“1-LEVEL” appears on the display.

3 Press \uparrow/\downarrow repeatedly to select “5-AUDIO”.

4 Press \oplus or \rightarrow to enter the menu.

5 Press \uparrow/\downarrow repeatedly to select “D.ASSIGN”.

6 Press \oplus or \rightarrow to enter the parameter.

7 Press \uparrow/\downarrow repeatedly to select a vacant digital audio input (for example, VIDEO 2).

8 Press \oplus or \rightarrow to enter your selection.

9 Press \uparrow/\downarrow repeatedly to select the input (for example, DVD) you want to assign to the digital audio input jack selected in step 7.

When the input is switched to “DVD”, the sound of the DVD player will also become a digital sound through the OPTICAL VIDEO 2/BD IN jack. The input you can assign varies for each audio input. For details, see the following “Assignable inputs for digital audio input”.

Assignable inputs for digital audio input

The initial setting is marked with underscore.

| Digital audio input | Assignable inputs | Display |
|---------------------|-------------------|----------------|
| VIDEO 2 OPT | VIDEO 1 | VD2-VD1 |
| | VIDEO 2 | <u>VD2-VD2</u> |
| | VIDEO 3 | VD2-VD3 |
| | DVD | VD2-DVD |
| | TV | VD2-TV |
| | SA-CD/CD | VD2-CD |
| DVD COAX | VIDEO 1 | DVD-VD1 |
| | VIDEO 2 | DVD-VD2 |
| | VIDEO 3 | DVD-VD3 |
| | DVD | <u>DVD-DVD</u> |
| | SAT | DVD-SAT |
| | TV | DVD-TV |
| | SA-CD/CD | DVD-CD |
| SAT OPT | VIDEO 1 | SAT-VD1 |
| | VIDEO 3 | SAT-VD3 |
| | DVD | SAT-DVD |
| | SAT | <u>SAT-SAT</u> |
| | TV | SAT-TV |
| | SA-CD/CD | SAT-CD |

Notes

- You cannot reassign more than one digital audio inputs to the same input.
- You cannot use the digital audio input for the original input when it has been assigned to another input.
- When you reassign the digital audio input, the INPUT MODE setting may change automatically (page 63).
- You cannot reassign the digital audio input to TUNER, XM Radio and DMPORT.

Naming inputs

You can enter a name of up to 8 characters for inputs and display it on the receiver's display. This is convenient for labeling the jacks with the names of the connected components.

1 Press the input button to select the input you want to create an index name for.

You can also use INPUT SELECTOR on the receiver.

2 Press RECEIVER.

The RECEIVER indicator lights up and receiver operation is activated.

3 Press MENU.

"1-LEVEL" appears on the display.

4 Press \uparrow/\downarrow repeatedly to select either "5-AUDIO" or "6-VIDEO".

5 Press \oplus or \rightarrow to enter the menu.

6 Press \uparrow/\downarrow to select "NAME IN".

7 Press \oplus or \rightarrow to enter the parameter.

The cursor flashes and you can select a character. Follow the procedure given in "To create an index name" (page 56).

Changing the display

You can check the sound field, etc., by changing the information on the display. Be sure to use the buttons on the receiver for this operation.

Press DISPLAY repeatedly.

Each time you press the button, the display changes cyclically as follows.

All inputs except the FM and AM band and XM Radio

Index name of the input^{a)} → Selected input
→ Sound field currently applied

FM and AM band

Preset station name^{a)} → Frequency → Sound field currently applied

XM Radio

Channel name → Channel number →
Category name → Artist name/Feature →
Song/program title → Sound field currently applied

^{a)}Index name appears only when you have assigned one to the input or preset station (page 56, 67). Index name does not appear when only blank spaces have been entered, or it is the same as the input name.

Note

Character or marks may not be displayed for some languages.

Using the Sleep Timer

You can set the receiver to turn off automatically at a specified time.

Press SLEEP repeatedly while the power is on.

Each time you press the button, the display changes cyclically as follows:

2-00-00 → 1-30-00 → 1-00-00 → 0-30-00
→ OFF

When Sleep Timer is activated, the display dims.

Note

If you press any buttons on the remote or receiver after the display dims, the display brightens up. After a while, the display dims again if no button is pressed.

Tip

To check the remaining time before the receiver turns off, press SLEEP. The remaining time appears on the display. If you press SLEEP again, the sleep timer will be canceled.

Recording using the receiver

Recording onto a CD-R

You can record onto a CD-R using the receiver. See the operating instructions supplied with your CD.

1 Press one of the input buttons to select the playback component.

You can also use INPUT SELECTOR on the receiver.

2 Prepare the playback component for playing.

For example, tune the radio station you want to record.

3 Prepare the recording component.

Insert a CD-R into the CD recorder and adjust the recording level.

4 Start recording on the recording component, then start playback on the playback component.

Note

Sound adjustments do not affect the signal output from the SA-CD/CD/CD-R OUT jacks.

Recording onto a recording media

You can record from an video component using the receiver. See the operating instructions supplied with your recording component.

1 Press one of the input buttons to select the playback component.

You can also use INPUT SELECTOR on the receiver.

2 Prepare the playback component for playing.

For example, insert the video tape you want to copy into the VCR.

3 Prepare the recording component.

Insert a blank video tape, etc. into the recording component (VIDEO 1) for recording.

4 Start recording on the recording component, then start playback on the playback component.

Notes

- Some sources contain copy guards to prevent recording. In this case, you may not be able to record from the source.
- When DMPORT input is selected and you have assigned VIDEO 1 input to DMPORT input, no video signals are output from the VIDEO 1 VIDEO OUT jack.

Programming the remote

You can program the remote to control non-Sony components by changing the code. Once the control signals have been memorized, you can use those components as part of your system.

Furthermore, you can also program the remote for Sony components that the remote is unable to control. Note that the remote can only control components that accept infrared wireless control signals.

1 Press RM SET UP.

The RM SET UP indicator slowly flashes.

2 Press the input button for the component you want to control.

For example, if you are going to control a CD player, press SA-CD/CD. The RM SET UP indicator lights up.

3 Press the numeric buttons to enter the numeric code (or one of the codes if more than one code exists) corresponding to the component and the maker of the component you want to control (except TV) .

See the tables on pages 71-74 for information on the numeric code(s) corresponding to the component and the maker of the component (the first digit and the last two digits of the numeric code correspond to the category and the maker's code respectively).

4 Press ENTER.

Once the numeric code has been verified, the RM SET UP indicator slowly flashes twice and the remote automatically exits the programming mode.

5 Repeat steps 1 to 4 to control other components.

Notes

- The indicator turns off while a valid button is pressed.
- In step 2, if several input buttons are pressed, only the last pressed button is valid.
- In step 2, if you press TUNER, you can only program the button to control a tuner (page 74).
- In step 3, if an input button is pressed, the new input is selected and the programming procedure returns to the beginning of step 3.
- For the numeric codes, only the last three numbers entered are valid.

To program the remote to control a TV

1 Press RM SET UP.

The RM SET UP indicator slowly flashes.

2 Press TV.

3 Press the numeric buttons to enter the numeric code (or one of the codes if more than one code exists) for TV. For details, see page 73.

4 Press ENTER.

Once the numeric code has been verified, the RM SET UP indicator slowly flashes twice and the remote automatically exits the programming mode.

To cancel programming

Press RM SET UP during any step. The RM SET UP indicator flashes 5 times in quick succession. The remote automatically exits the programming mode.

To activate the input after programming

Press the programmed button to activate the input you want.

If programming is unsuccessful, check the following:

- If the indicator does not light up in step 1, the batteries are weak. Replace both batteries.
- If the indicator flashes 5 times in quick succession while entering the numeric code, an error has occurred. Start again from step 1.

To clear the memory of the remote

To clear all programmed, do the following to reset the remote to factory settings.

While holding down MASTER VOL –, press and hold I/⏻ and then press AV I/⏻.

The indicator flashes 3 times, then goes off.

The numeric codes corresponding to the component and the maker of the component

Use the numeric codes in the tables below to control non-Sony components and also Sony components that the remote is normally unable to control. Since the remote signal that a component accepts differs depending on the model and year of the component, more than one numeric code may be assigned to a component. If you fail to program your remote using one of the codes, try using other codes.

Notes

- The numeric codes are based on the latest information available for each brand. There is a chance, however, that your component will not respond to some or all of the codes.
- All of the input buttons on this remote may not be available when used with your particular component.

To control a CD player

| Maker | Code(s) |
|-----------|---------------|
| SONY | 101, 102, 103 |
| DENON | 104, 123 |
| JVC | 105, 106, 107 |
| KENWOOD | 108, 109, 110 |
| MAGNAVOX | 111, 116 |
| MARANTZ | 116 |
| ONKYO | 112, 113, 114 |
| PANASONIC | 115 |
| PHILIPS | 116 |
| PIONEER | 117 |
| TECHNICS | 115, 118, 119 |
| YAMAHA | 120, 121, 122 |

To control a DAT deck

| Maker | Code(s) |
|---------|---------|
| SONY | 203 |
| PIONEER | 219 |

To control an MD deck

| Maker | Code(s) |
|---------|---------|
| SONY | 301 |
| DENON | 302 |
| JVC | 303 |
| KENWOOD | 304 |

To control a tape deck

| Maker | Code(s) |
|-----------|--------------------|
| SONY | 201, 202 |
| DENON | 204, 205 |
| KENWOOD | 206, 207, 208, 209 |
| NAKAMICHI | 210 |
| PANASONIC | 216 |
| PHILIPS | 211, 212 |
| PIONEER | 213, 214 |
| TECHNICS | 215, 216 |
| YAMAHA | 217, 218 |

To control an LD player

| Maker | Code(s) |
|---------|---------------|
| SONY | 601, 602, 603 |
| PIONEER | 606 |

To control a video CD player

| Maker | Code(s) |
|-------|---------|
| SONY | 605 |

To control a DVD/VHS COMBO

| Maker | Code(s) |
|-------|---------|
| SONY | 411 |

To control a DVD/HDD COMBO

| Maker | Code(s) |
|-------|---------|
| SONY | 403 |

To control a VCR

| Maker | Code(s) |
|------------------|-----------------------------------|
| SONY | 701, 702, 703, 704, 705, 706 |
| AIWA* | 710, 750, 757, 758 |
| AKAI | 707, 708, 709, 759 |
| BLAUPUNKT | 740 |
| EMERSON | 711, 712, 713, 714, 715, 716, 750 |
| FISHER | 717, 718, 719, 720 |
| GENERAL ELECTRIC | 721, 722, 730 |
| GOLDSTAR/LG | 723, 753 |
| GRUNDIG | 724 |
| HITACHI | 722, 725, 729, 741 |
| ITT/NOKIA | 717 |
| JVC | 726, 727, 728, 736 |
| MAGNAVOX | 730, 731, 738 |
| MITSUBISHI/MGA | 732, 733, 734, 735 |
| NEC | 736 |
| PANASONIC | 729, 730, 737, 738, 739, 740 |
| PHILIPS | 729, 730, 731 |
| PIONEER | 729 |
| RCA/PROSCAN | 722, 729, 730, 731, 741, 747 |

| Maker | Code(s) |
|------------|--------------------|
| SAMSUNG | 742, 743, 744, 745 |
| SANYO | 717, 720, 746 |
| SHARP | 748, 749 |
| TELEFUNKEN | 751, 752 |
| TOSHIBA | 747, 756 |
| ZENITH | 754 |

* If an AIWA VCR does not work even though you enter the code for AIWA, enter the code for Sony instead.

To control a DVD player

| Maker | Code(s) |
|------------|---------------|
| SONY | 401, 402, 403 |
| RCA | 414 |
| SAMSUNG | 416, 422 |
| ZENITH | 418, 420 |
| PANASONIC | 406, 408, 425 |
| PHILIPS | 407 |
| PIONEER | 409, 410 |
| TOSHIBA | 404, 421 |
| DENON | 405 |
| BROKSONIC | 424 |
| HITACHI | 416 |
| JVC | 415, 423 |
| MITSUBISHI | 419 |
| ORITRON | 417 |

To control a DVD recorder

| Maker | Code(s) |
|-------|---------|
| SONY | 403 |

To control a TV

| Maker | Code(s) |
|----------------|---|
| SONY | 501 |
| AIWA | 501, 536, 539 |
| AKAI | 503 |
| AOC | 503 |
| CENTURION | 566 |
| CORONADO | 517 |
| CURTIS-MATHES | 503, 551, 566, 567 |
| DAYTRON | 517, 566 |
| DAEWOO | 504, 505, 506, 507, 515, 544 |
| FISHER | 508, 545 |
| FUNAI | 548 |
| FUJITSU | 528 |
| GOLDSTAR/LG | 503, 512, 515, 517, 534, 544, 556, 568 |
| GRUNDIG | 511, 533, 534 |
| HITACHI | 503, 513, 514, 515, 517, 519, 544, 557, 571 |
| ITT/NOKIA | 521, 522 |
| J.C. PENNY | 503, 510, 566 |
| JVC | 516, 552 |
| KMC | 517 |
| MAGNAVOX | 503, 515, 517, 518, 544, 566 |
| MARANTZ | 527 |
| MITSUBISHI/MGA | 503, 519, 527, 544, 566, 568 |
| NEC | 503, 517, 520, 540, 544, 554, 566 |
| NOROMENDE | 530, 558 |
| NOKIA | 521, 522, 573, 575 |
| PANASONIC | 509, 524, 553, 559, 572 |
| PHILIPS | 515, 518, 557, 570, 571 |
| PHILCO | 503, 504, 514, 517, 518 |
| PIONEER | 509, 525, 526, 540, 551, 555 |
| PORTLAND | 503 |
| QUASAR | 509, 535 |

| Maker | Code(s) |
|--------------|---|
| RADIO SHACK | 503, 510, 527, 565, 567 |
| RCA/PROSCAN | 503, 510, 523, 529, 544 |
| SAMSUNG | 503, 515, 517, 531, 532, 534, 544, 556, 557, 562, 563, 566, 569 |
| SAMPO | 566 |
| SABA | 530, 537, 547, 549, 558 |
| SANYO | 508, 545, 546, 560, 567 |
| SCOTT | 503, 566 |
| SEARS | 503, 508, 510, 517, 518, 551 |
| SHARP | 517, 535, 550, 561, 565 |
| SYLVANIA | 503, 518, 566 |
| TELEFUNKEN | 530, 537, 538, 547, 549, 558 |
| THOMSON | 530, 537, 547, 549 |
| TOSHIBA | 535, 539, 540, 541, 551 |
| ZENITH | 542, 543, 567 |
| TEKNIKA | 517, 518, 567 |
| WARDS | 503, 517, 566 |
| YORK | 566 |
| GE | 503, 509, 510, 544 |
| LOEWE | 515, 534, 556 |

To control a satellite tuner

| Maker | Code(s) |
|---------------------------|-----------------------------------|
| SONY | 801, 802, 803, 804, 824, 825, 865 |
| AMSTRAD | 845, 846 |
| BskyB | 862 |
| GENERAL ELECTRIC (GE) | 866 |
| GRUNDIG | 859, 860 |
| HUMAX | 846, 847 |
| THOMSON | 857, 861, 864 |
| PACE | 848, 849, 850, 852, 862, 863, 864 |
| PANASONIC | 818, 855 |
| PHILIPS | 856, 857, 858, 859, 860, 864, 874 |
| NOKIA | 851, 853, 854, 864 |
| RCA/PROSCAN | 866, 871 |
| BITA/HITACHI | 868 |
| HUGHES | 867 |
| JVC/Echostar/Disk Network | 873 |
| MITSUBISHI | 872 |
| SAMSUNG | 875 |
| TOSHIBA | 869, 870 |

To control a cable box

| Maker | Code(s) |
|-----------------------|--|
| SONY | 821, 822, 823 |
| HAMLIN/REGAL | 836, 837, 838, 839, 840 |
| JERROLD/G.I./MOTOROLA | 806, 807, 808, 809, 810, 811, 812, 813, 814, 819 |
| JERROLD | 830, 831 |
| OAK | 841, 842, 843 |
| PANASONIC | 816, 826, 832, 833, 834, 835 |
| PHILIPS | 830, 831 |
| PIONEER | 828, 829 |
| RCA | 805 |
| SCIENTIFIC ATLANTA | 815, 816, 817 |
| TOCOM/PHILIPS | 830, 831 |
| ZENITH | 826, 827 |

To control a tuner

| Maker | Code(s) |
|--------------|----------------|
| SONY | 002, 005 |

To control a Blu-ray disc recorder

| Maker | Code(s) |
|--------------|----------------|
| SONY | 310, 311, 312 |

To control a PSX

| Maker | Code(s) |
|--------------|----------------|
| SONY | 313, 314, 315 |

Glossary

■ Component video

A format for transmitting video signal information consisting of three separate signals: luminance Y, chrominance Pb, and chrominance Pr. High quality pictures, such as DVD video or HDTV pictures, are transmitted more faithfully. The three jacks are color coded green, blue and red.

■ Composite video

A standard format for transmitting video signal information. The luminance signal Y and chrominance signal C are combined and transmitted together.

■ Dolby Digital

Digital audio encoding/decoding technology developed by Dolby Laboratories, Inc. It consists of front (left/right), center, surround (left/right) and sub woofer channels. It is a designated audio standard for DVD-video and also known as 5.1 channel surround. Since surround information is recorded and reproduced in stereo, more realistic sound with fuller presence is delivered than with Dolby surround.

■ Dolby Pro Logic II

This technology converts 2 channel stereo recorded audio into 5.1 channel for playback. There is a MOVIE mode for movies and MUSIC mode for stereo sources such as music. Old movies encoded in the traditional stereo format can be enhanced with 5.1 channel surround sound.

■ Dolby Surround (Dolby Pro Logic)

Audio processing technology developed by Dolby Laboratories, Inc. Center and mono surround information is matrixed into two stereo channels. When reproduced, audio is decoded and output in 4ch surround sound. This is the most common audio processing method for DVD-video.

■ DTS Digital Surround

Digital audio encoding/decoding technology for theaters developed by DTS, Inc. It compresses audio less than Dolby Digital, delivering a higher quality sound reproduction.

■ HDMI (High-Definition Multimedia Interface)

HDMI is an interface that support both video and audio on a single digital connection. The HDMI connection carries standard to high definition video signals and multi-channel audio signals to audio video components, such as HDMI equipped TVs, in digital form without degradation. The HDMI specification supports HDCP (High-bandwidth Digital Contents Protection), a copy protection technology that incorporates coding technology for digital video signals.

■ Sampling frequency

To convert analog audio to digital, analog data should be quantified. This process is called sampling, and the number of times per second the analog data is quantified is called the sampling frequency. A standard music CD stores data quantified at 44,100 times per second, which is expressed as a sampling frequency of 44.1 kHz. Generally speaking, a higher sampling frequency means better sound quality.

Precautions

On safety

Should any solid object or liquid fall into the cabinet, unplug the receiver and have it checked by qualified personnel before operating it any further.

On power sources

- Before operating the receiver, check that the operating voltage is identical with your local power supply.

The operating voltage is indicated on the nameplate on the back of the receiver.

- The unit is not disconnected from the AC power source (mains) as long as it is connected to the wall outlet, even if the unit itself has been turned off.
- If you are not going to use the receiver for a long time, be sure to disconnect the receiver from the wall outlet. To disconnect the AC power cord, grasp the plug itself; never pull the cord.
- One blade of the plug is wider than the other for the purpose of safety and will fit into the wall outlet only one way. If you are unable to insert the plug fully into the outlet, contact your dealer.
- The AC power cord must be changed only at a qualified service shop.

On heat buildup

Although the receiver heats up during operation, this is not a malfunction. If you continuously use this receiver at a large volume, the cabinet temperature of the top, side and bottom rises considerably. To avoid burning yourself, do not touch the cabinet.

On placement

- Place the receiver in a location with adequate ventilation to prevent heat buildup and prolong the life of the receiver.
- Do not place the receiver near heat sources, or in a place subject to direct sunlight, excessive dust, or mechanical shock.
- Do not place anything on top of the cabinet that might block the ventilation holes and cause malfunctions.
- Do not place the receiver near equipment such as a television, VCR, or tape deck. (If the receiver is being used in combination with a television, VCR, or tape deck, and is placed too close to that equipment, noise may result, and picture quality may suffer. This is especially likely when using an indoor antenna. Therefore, we recommend using an outdoor antenna.)
- Use caution when placing the receiver or speakers on surfaces that have been specially treated (with wax, oil, polish, etc.) as staining or discoloration of the surface may result.

On operation

Before connecting other components, be sure to turn off and unplug the receiver.

If you encounter color irregularity on a nearby TV screen

The front and center speakers and the sub woofer are magnetically shielded to allow it to be installed near a TV set. However, color irregularities may still be observed on certain types of TV sets.

As the surround speakers are not magnetically shielded, we recommend that you place the surround speakers slightly further away from the TV set (page 14).

If color irregularity is observed...

Turn off the TV set, then turn it on again after 15 to 30 minutes.

If color irregularity is observed again...

Place the speaker further away from the TV set.

If howling occurs

Reposition the speakers or turn down the volume on the receiver.

On cleaning

Clean the cabinet, panel, and controls with a soft cloth slightly moistened with a mild detergent solution. Do not use any type of abrasive pad, scouring powder, or solvent, such as alcohol or benzine.

If you have any questions or problems concerning your receiver, please consult your nearest Sony dealer.

Troubleshooting

If you experience any of the following difficulties while using the receiver, use this troubleshooting guide to help you remedy the problem.

Audio

There is no sound, no matter which component is selected, or only a very low-level sound is heard.

- Check that the speakers and components are connected securely.
- Check that both the receiver and all components are turned on.
- Check that MASTER VOLUME is not set to “VOL MIN”.
- Check that the SPEAKERS (OFF/A/B/A+B) is not set to “OFF”.
- Check that headphone is not connected.
- Press MUTING to cancel the muting function.
- Check that you have selected the correct component with the input buttons (page 34).
- The protective device on the receiver has been activated. Turn off the receiver, eliminate the short-circuit problem, and turn on the power again.

There is no sound from a specific component.

- Check that the component is connected correctly to the audio input jacks for that component.
- Check that the cord(s) used for the connection is (are) fully inserted into the jacks on both the receiver and the component.

There is no sound from one of the front speakers.

- Connect a pair of headphones to the PHONES jack to verify that sound is output from the headphones. If only one channel is output from the headphones, the component may not be connected to the receiver correctly. Check that all the cords are fully inserted into the jacks on both the receiver and the component. If both channels are output from the headphones, the front speaker may not be connected to the receiver correctly. Check the connection of the front speaker which is not outputting any sound.
- Make sure you have connected to both the L and R jacks of an analog component, and not only to either the L or R jack. Use an audio cord (not supplied).

There is no sound from analog 2 channel sources.

- Check that the INPUT MODE is not set to “COAX IN” or “OPT IN” for the selected input (page 63).

There is no sound from digital sources (from COAXIAL or OPTICAL input jack).

- Check that the INPUT MODE is not set to “ANALOG” (page 63). Check that the INPUT MODE is not set to “COAX IN” for the sources from the OPTICAL input jack, or to “OPT IN” for the sources from the COAXIAL input jack.

The source sound input to the HDMI jack on the receiver is not output from the TV speaker.

- Check the HDMI connection.
- You cannot listen to the Super Audio CD by connecting HDMI.
- Depending on the playback component, you may need to set up the component. Refer to the operating instructions supplied with each component.

The left and right sounds are unbalanced or reversed.

- Check that the speakers and components are connected correctly and securely.
- Adjust the balance parameters using the LEVEL menu.

There is severe hum or noise.

- Check that the speakers and components are connected securely.
- Check that the connecting cords are away from a transformer or motor, and at least 10 feet away from a TV set or fluorescent light.
- Move your audio components away from the TV.
- The plugs and jacks are dirty. Wipe them with a cloth slightly moistened with alcohol.

There is no sound, or only a very low-level sound is heard from the center/surround speakers.

- Select a CINEMA STUDIO EX mode (page 50).
- Adjust the speaker level (page 33).

There is no sound from the sub woofer.

- Check that the sub woofer is connected correctly and securely.
- Make sure you have turned on your sub woofer.

The surround effect cannot be obtained.

- Make sure the sound field function is on (press MOVIE or MUSIC).
- Sound fields do not function for signals with a sampling frequency of more than 48 kHz.

Dolby Digital or DTS multi channel sound is not reproduced.

- Check that the DVD, etc. you are playing is recorded in Dolby Digital or DTS format.
- When connecting the DVD player, etc., to the digital input jacks of this receiver, check the audio setting (the settings for the audio output) of the connected component.

The MULTI CHANNEL DECODING lamp does not light up in blue.

- Check that the playback component is connected to a digital jack and the input is selected properly on this receiver.
- Check whether the input source of the software being played back corresponds to the multi channel format.
- Check whether the setup on the playback component is set to multi channel sound.

Recording cannot be carried out.

- Check that the components are connected correctly.
- Select the source component using the input buttons.

Video

There is no picture or an unclear picture appears on the TV screen or monitor.

- Select the appropriate input using the input buttons.
- Set your TV to the appropriate input mode.
- Move your audio components away from the TV.
- Assign the component video input correctly.
- Assign the composite video input to DMPORT input correctly.
- Depending on the DIGITAL MEDIA PORT adapter, video output may not be possible.

The source image input to the HDMI jack on the receiver is not output from the TV.

- Check the HDMI connection.
- Depending on the playback component, you may need to set up the component. Refer to the operating instructions supplied with the each component.

Recording cannot be carried out.

- Check that the components are connected correctly.
- Select the source component using the input buttons.

Tuner

The FM reception is poor.

- Use a 75-ohm coaxial cable (not supplied) to connect the receiver to an outdoor FM antenna as shown below. If you connect the receiver to an outdoor antenna, ground it against lightning. To prevent a gas explosion, do not connect the ground wire to a gas pipe.

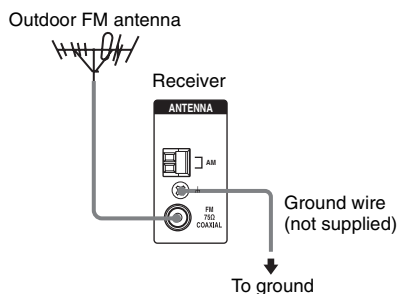

Radio stations cannot be tuned in.

- Check that the antennas are connected securely. Adjust the antennas and connect an external antenna, if necessary.
 - The signal strength of the stations is too weak (when tuning in with automatic tuning). Use direct tuning.
 - Make sure you set the tuning interval correctly (when tuning in AM stations with direct tuning).
 - No stations have been preset or the preset stations have been cleared (when tuning by scanning preset stations). Preset the stations (page 54).
 - Press DISPLAY repeatedly on the receiver so that the frequency appears on the display.
-

Remote control

The remote does not function.

- Point the remote at the remote sensor on the receiver.
 - Remove any obstacles in the path between the remote and the receiver.
 - Replace all the batteries in the remote with new ones, if they are weak.
 - Make sure you select the correct input on the remote.
 - The AUX button on the remote is not available for receiver operation.
 - When you operate a programmed of non-Sony component, the remote may not function properly depending on the model and the maker of the component.
-

Error messages

If there is a malfunction, the display shows a message. You can check the condition of the system by the message. Refer to the following table to solve the problem. If any problem persists, consult your nearest Sony dealer. If an error message appears while you perform Auto Calibration, see “Error and warning codes” (page 31) to solve the problem.

DEC. EROR

Appears when a signal the receiver cannot decode (ex. DTS-CD) is input and “DEC. PRI.” on the AUDIO menu is set to “DEC. PCM”. Set it to “DEC. AUTO” (page 40).

PROTECT

Irregular current is output from the speakers. The receiver will automatically turn off after a few seconds. Check the speaker connection and turn on the power again.

If you are unable to remedy the problem using the troubleshooting guide

Clearing the receiver’s memory may remedy the problem (page 27). However, note that all memorized settings will be reset to their factory settings and you will have to readjust all settings on the receiver.

If the problem persist

Consult your nearest Sony dealer. Note that if service personnel changes some parts during repair, these parts may be retained.

Reference sections for clearing the receiver’s memory

| To clear | See |
|-------------------------|---------|
| All memorized settings | page 27 |
| Customized sound fields | page 52 |

Specifications

AUDIO POWER SPECIFICATIONS

POWER OUTPUT AND TOTAL HARMONIC DISTORTION:

With 6 ohm loads, both channels driven, from 120 – 20,000 Hz; rated 90 watts per channel minimum RMS power, with no more than 1% total harmonic distortion from 250 milliwatts to rated output.

Amplifier section

Power Output¹⁾

Models of area code U

Stereo mode (rated)

(6 ohms 1 kHz, THD 1%)

90 W + 90 W

Surround mode (reference)

(6 ohms 1 kHz, THD 10%)

RMS Output²⁾

FRONT: 140 W/ch

CENTER: 140 W

SURROUND: 140 W/ch

¹⁾Measured under the following conditions:

| Area code | Power requirements |
|-----------|--------------------|
| U | 120 V AC, 60 Hz |

²⁾Reference power output for front, center and surround speakers. Depending on the sound field settings and the source, there may be no sound output.

Inputs

| | |
|-------------------|----------------------------------|
| Analog | Sensitivity: 800 mV/ 50 kohms |
| Digital (Coaxial) | Impedance: 75 ohms |

Outputs (Analog)

| | |
|-----------|------------------------------|
| AUDIO OUT | Voltage: 800 mV/ 10 kohms |
| SUBWOOFER | Voltage: 2 V/1 kohms |

Tone

| | |
|-------------|------------------|
| Gain levels | ±6 dB, 1 dB step |
|-------------|------------------|

Reproduction frequency range:

28 – 20,000 Hz

FM tuner section

Tuning range 87.5 - 108.0 MHz

Antenna FM wire antenna

Antenna terminals 75 ohms, unbalanced

Intermediate frequency

10.7 MHz

AM tuner section

Tuning range

With 10-kHz tuning scale:

530 – 1,710 kHz³⁾

With 9-kHz tuning scale:

531 – 1,710 kHz³⁾

Antenna Loop antenna

Intermediate frequency

450 kHz

³⁾You can change the AM tuning scale to 9 kHz or 10 kHz. After tuning in any AM station, turn off the receiver. While holding down TUNING MODE, press I/⏻. All preset stations will be erased when you change the tuning scale. To reset the scale to 10 kHz (or 9 kHz), repeat the procedure.

Video section

Inputs/Outputs

Video: 1 V_{p-p}, 75 ohms

COMPONENT VIDEO:

Y: 1 V_{p-p}, 75 ohms

P_B/C_B: 0.7 V_{p-p},
75 ohms

P_R/C_R: 0.7 V_{p-p},
75 ohms

80 MHz HD Pass Through

General

Power requirements

| Area code | Power requirements |
|-----------|--------------------|
| U | 120 V AC, 60 Hz |

Power output (DIGITAL MEDIA PORT)

DC OUT 5 V, 700 mA

Power consumption

| Area code | Power consumption |
|-----------|-------------------|
| U | 170 W |

Power consumption (during standby mode)

0.3 W

Dimensions (w/h/d) (Approx.)

430 × 157.5 × 316 mm
(17 × 6 1/4 × 12 1/2 inches)
including projecting parts
and controls

Mass (Approx.)

8.0 kg (17 lb 11 oz)

Speaker section

• Front speakers (SS-MSP7000)

• Center speaker (SS-CNP900)

• Surround speakers (SS-SRP7000)

Front speakers 2 way, magnetically shielded

Center speaker Full range, magnetically shielded

Surround speakers Full range

Speaker units

Front speakers Tweeter: 40 mm cone type
Woofer: 80 mm cone type

Center/surround speakers

80 mm cone type

Enclosure type Bass reflex

Rated Impedance 6 ohms

Dimension (w/h/d) (Approx.)

Front speakers 130 × 211 × 136 mm
(5 1/8 × 8 1/4 × 5 3/8 inches)

Center speaker 245 × 109 × 136 mm
(9 5/8 × 4 3/8 × 5 3/8 inches)

Surround speakers 115 × 169 × 141 mm
(4 1/2 × 6 5/8 × 5 1/2 inches)

Mass (Approx.)

Front speakers 1.4 kg (3 lb 2 oz)

Center speaker 1.3 kg (2 lb 14 oz)

Surround speakers 1.0 kg (2 lb 4 oz)

• Sub woofer (SA-WP780)

AUDIO POWER SPECIFICATIONS

POWER OUTPUT AND TOTAL HARMONIC DISTORTION:

With 6 ohm loads, from 28 – 200 Hz; rated 120 watts, minimum RMS power, with no more than 1% total harmonic distortion from 250 milliwatts to rated output.

Speaker system Active subwoofer, magnetically shielded

Speaker unit 200 mm cone type

Enclosure type Acoustically loaded bass reflex

RMS output 200 W

Input LINE IN (input pin jacks)

Power requirements 120 V AC, 60 Hz

Power consumption 80 W

Dimensions (w/h/d) (Approx.)

270 × 331 × 380 mm
(10 5/8 × 13 × 15 inches)

Mass (Approx.) 8.3 kg (18 lb 5 oz)

Supplied speakers

- Front speakers (2)
- Center speaker (1)
- Surround speakers (2)
- Sub woofer (1)

Supplied accessories

- FM wire antenna (1)
- AM loop antenna (1)
- Monaural audio cord (1)
- Speaker cords
 - Long (2)
 - Short (3)
- Coaxial digital cord (1)
- Footpads
 - Speakers (20)
 - Sub woofer (4)
- Remote commander RM-AAP016 (1)
- R6 (size-AA) batteries (2)
- Optimizer microphone (ECM-AC2 or ECM-AC2a) (1)

For details on the area code of the component you are using, see page 3.

Design and specifications are subject to change without notice.

Index

Numerics

- 2CH STEREO 51
- 5.1 channel 14

A

- AUTO CALIBRATION 29
- AUTO FORMAT DIRECT (A.F.D.) 47

B

- Blu-ray disc player 23

C

- CD player
 - connecting 17
 - playback 36
- CD recorder connecting 17

D

- DIGITAL ASSIGN 66
- Digital Cinema Sound (DCS) 50
- DIGITAL MEDIA PORT
 - connecting 64
 - input 63
 - video assign 44
- Dolby Digital 75
- DTS 75
- DVD player
 - connecting 18
 - playback 37
- DVD recorder
 - connecting 18

E

- Error messages 80

H

- HDMI
 - connecting 18

I

- Initial setup 27
- INPUT MODE 63

M

- Menu
 - A. CAL 47
 - AUDIO 43
 - LEVEL 41
 - SUR 42
 - SYSTEM 45
 - TONE 42
 - TUNER 43
 - VIDEO 44
- Muting 34

N

- Naming 55, 67

P

- Portable audio
 - connecting 25
 - sound field 50

R

- Recording
 - onto a CD-R 69
 - onto a recording media 69
- Remote commander 10

S

- Satellite tuner
 - connecting 18
- Selecting
 - component 34
 - sound field 49
 - speaker system 28
- Sleep Timer 68
- Sound fields
 - resetting 52
 - selecting 49
- Speakers
 - connecting 16
 - installing 14
- Super Audio CD player
 - playback 36

T

- TEST TONE 33
- Tuner
 - connecting 26
- Tuning
 - automatically 52
 - directly 53
 - to preset stations 55
- TV
 - connecting 18

V

- VCR
 - connecting 18
- Video game
 - connecting 18

X

- XM Radio 56



* 3 0 9 3 5 5 0 1 1 * (1)