

# ENGINE LUBRICATION & COOLING SYSTEMS

## SECTION LC

GI

MA

EM

LC

EF &  
EC

FE

CL

MT

AT

TF

PD

FA

RA

BR

ST

BF

HA

EL

IDX

155

## CONTENTS

<b>PREPARATION/PRECAUTION</b> .....	2
Special Service Tools.....	2
Liquid Gasket Application Procedure.....	2

<b>VG30E</b>	
<b>ENGINE LUBRICATION SYSTEM</b> .....	3
Lubrication Circuit.....	3
Oil Pressure Check.....	3
Oil Pump.....	4
<b>ENGINE COOLING SYSTEM</b> .....	6
Cooling Circuit.....	6
System Check.....	6
Water Pump.....	7
Thermostat.....	8
Radiator.....	8
Cooling Fan.....	9

<b>KA24E</b>	
<b>ENGINE LUBRICATION SYSTEM</b> .....	10
Lubrication Circuit.....	10
Oil Pressure Check.....	11
Oil Pump.....	11
<b>ENGINE COOLING SYSTEM</b> .....	13
Cooling Circuit.....	13
System Check.....	13
Water Pump.....	14
Thermostat.....	15
Radiator.....	16
Cooling Fan.....	16

<b>VG30E, KA24E</b>	
<b>SERVICE DATA AND SPECIFICATIONS (SDS)</b> .....	17
Engine Lubrication System (VG30E).....	17
Engine Cooling System (VG30E).....	17
Engine Lubrication System (KA24E).....	17
Engine Cooling System (KA24E).....	17

## PREPARATION/PRECAUTION

### Special Service Tools

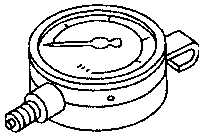
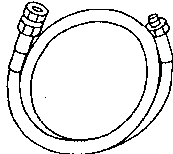
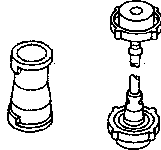
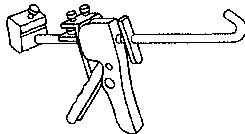
Tool number (Kent-Moore No.) Tool name	Description	Engine application	
		VG30E	KA24E
ST25051001 (J25695-1) Oil pressure gauge	 NT050	X	X
ST25052000 (J25695-2) Hose	 NT051	X	X
EG17650301 (J33984-A) Radiator cap tester adapter	 NT053	X	X
WS39930000 ( — ) Tube presser	 NT052	X	X

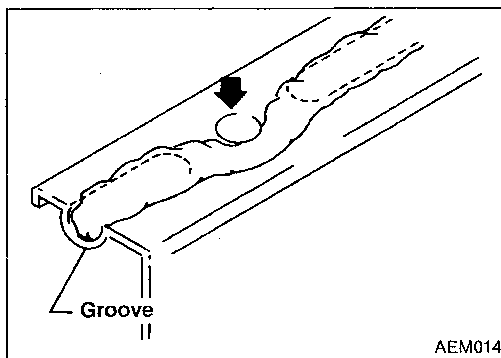
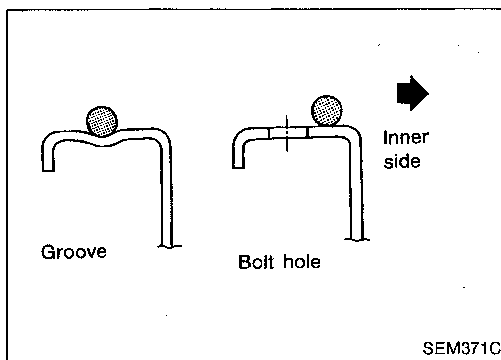

### Liquid Gasket Application Procedure

- a. Before applying liquid gasket, use a scraper to remove all traces of old liquid gasket from mating surface.
- b. Apply a continuous bead of liquid gasket to mating surfaces. (Use Genuine Liquid Gasket or equivalent.)
  - Be sure liquid gasket is 3.5 to 4.5 mm (0.138 to 0.177 in) wide (for oil pan).
  - Be sure liquid gasket is 2.0 to 3.0 mm (0.079 to 0.118 in) wide (in areas except oil pan).
- c. Apply liquid gasket to inner sealing surface around hole perimeter area.  
(Assembly should be done within 5 minutes after coating.)
- d. Wait at least 30 minutes before refilling engine oil and engine coolant.

Lubrication Circuit

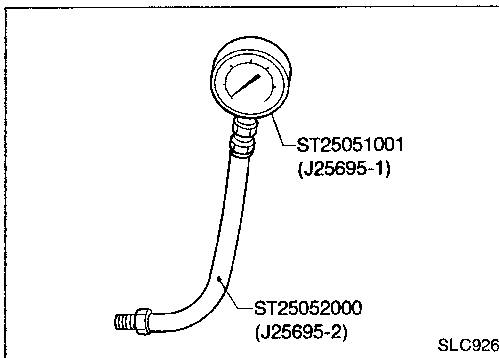
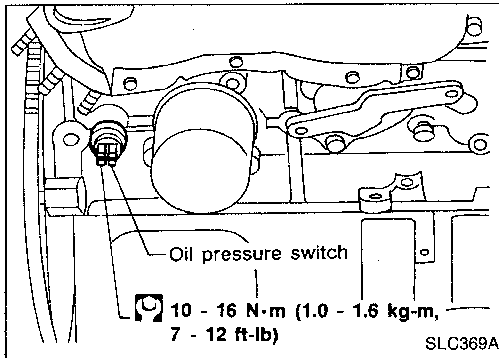
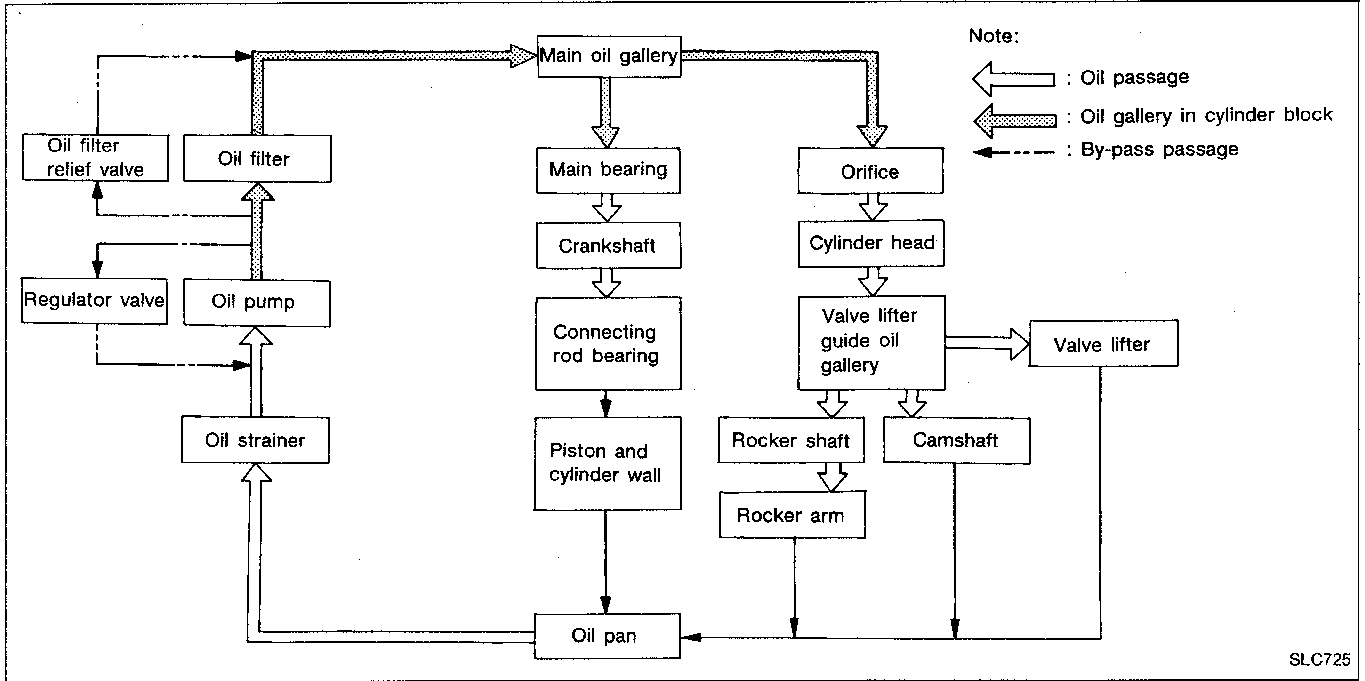

Oil Pressure Check

WARNING:

- Be careful not to burn yourself, as the engine and oil may be hot.
- Oil pressure check should be done in "Neutral" gear position.

1. Check oil level.
2. Remove oil pressure switch.
3. Install pressure gauge.
4. Start engine and warm it up to normal operating temperature.

5. Check oil pressure with engine running under no-load.

Engine speed rpm	Approximate discharge pressure kPa (kg/cm <sup>2</sup> , psi)
Idle speed	More than 59 (0.6, 9)
3,200	363 - 451 (3.7 - 4.6, 53 - 65)

If difference is extreme, check oil passage and oil pump for oil leaks.

6. Install oil pressure switch with sealant.

GI

MA

EM

LC

EF & EC

FE

CL

MT

AT

TF

PD

FA

RA

BR

ST

BF

HA

EL

IDX

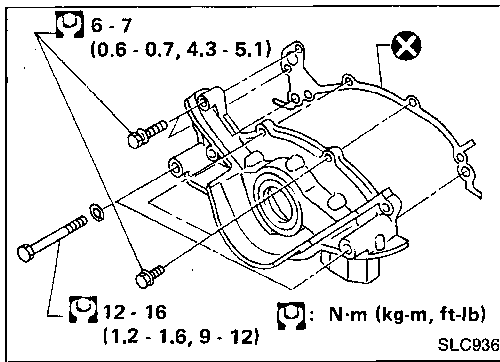

**Oil Pump**

**REMOVAL**

1. Drain oil.
2. Remove oil pan.
3. Remove oil pump assembly.

**DISASSEMBLY AND ASSEMBLY**

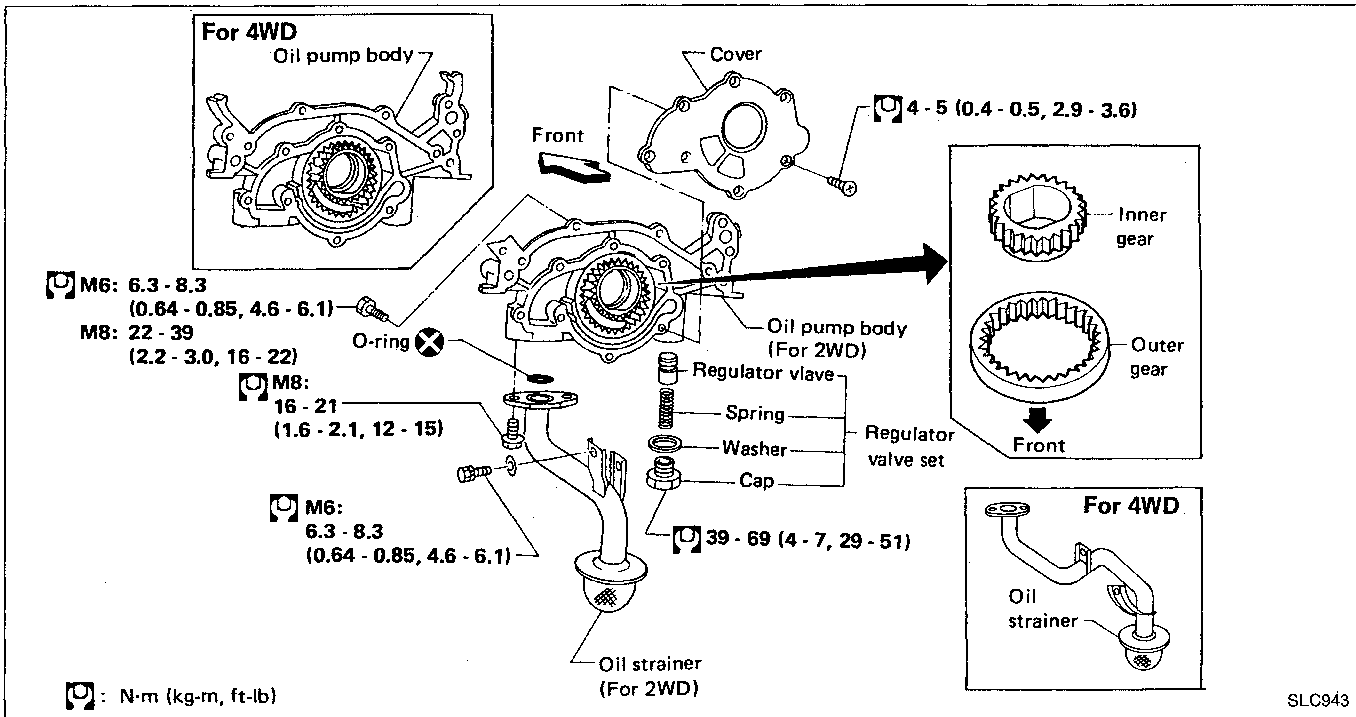

- Always replace with new oil seal and gasket.
- When installing oil pump, apply engine oil to inner and outer gears.
- Be sure that O-ring is properly installed.

**Oil Pump (Cont'd)**

**INSPECTION**

Using a feeler gauge, check the following clearances:

**Standard clearance:**

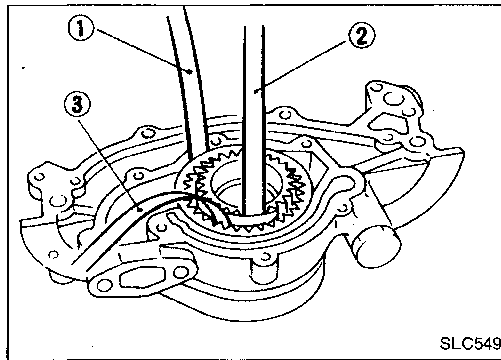

	Unit: mm (in)
Body to outer gear clearance ①	0.11 - 0.20 (0.0043 - 0.0079)
Inner gear to crescent clearance ②	0.12 - 0.23 (0.0047 - 0.0091)
Outer gear to crescent clearance ③	0.21 - 0.32 (0.0083 - 0.0126)
Housing to inner gear clearance ④	0.05 - 0.09 (0.0020 - 0.0035)
Housing to outer gear clearance ⑤	0.05 - 0.11 (0.0020 - 0.0043)

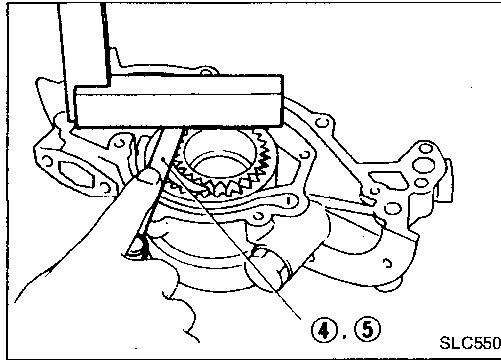

**If any clearance exceeds the limit, replace gear set or entire oil pump assembly.**

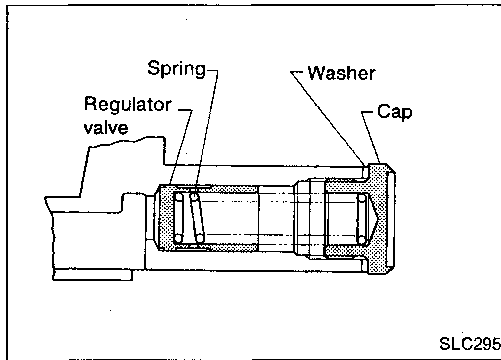

**REGULATOR VALVE INSPECTION**

1. Visually inspect components for wear and damage.
2. Check oil pressure regulator valve sliding surface and valve spring.
3. Coat regulator valve with engine oil and check to make sure that it falls smoothly into the valve hole by its own weight.

**If damaged, replace regulator valve set or oil pump assembly.**

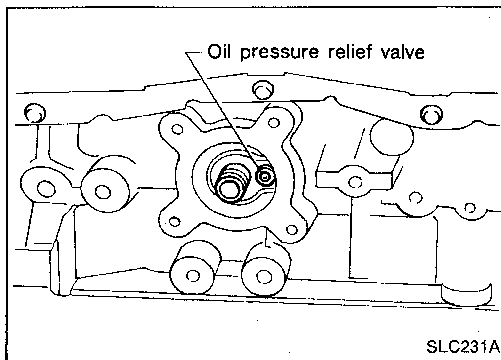

**OIL PRESSURE RELIEF VALVE INSPECTION**

Inspect oil pressure relief valve for movement, cracks and breaks by pushing the ball. If replacement is necessary, remove valve by prying it out with a suitable tool. Install a new valve by tapping it.

GI

MA

EM

LC

EF &  
EC

FE

CL

MT

AT

TF

PD

FA

RA

BR

ST

BF

HA

EL

IDX

Cooling Circuit

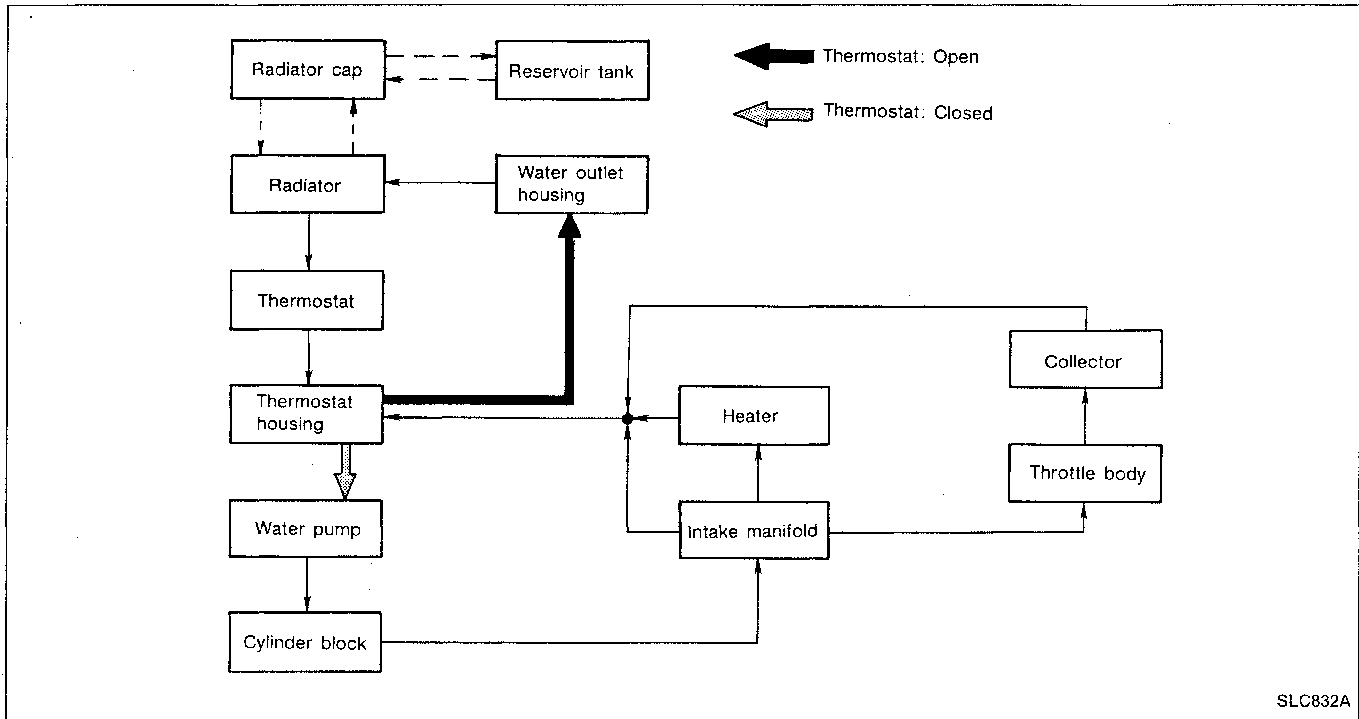

SLC832A

System Check

**WARNING:**

Never remove the radiator cap when the engine is hot; serious burns could be caused by high pressure fluid escaping from the radiator.

Wrap a thick cloth around the cap and carefully remove the cap by turning it a quarter turn to allow built-up pressure to escape. Then continue turning the cap until it can be removed safely.

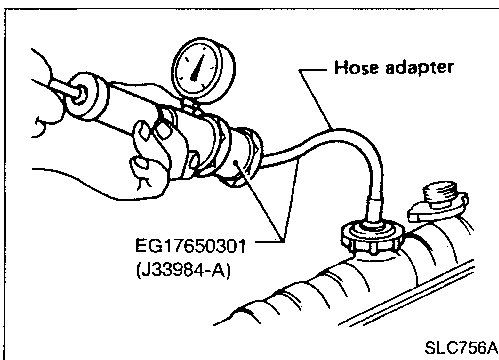

SLC756A

**CHECKING COOLING SYSTEM HOSES**

Check hoses for improper attachment, leaks, cracks, damage, loose connections, chafing and deterioration.

**CHECKING COOLING SYSTEM FOR LEAKS**

To check for leakage, apply pressure to the cooling system with a tester.

Testing pressure: 157 kPa (1.6 kg/cm<sup>2</sup>, 23 psi)

**CAUTION:**

Higher than the specified pressure may cause radiator damage.

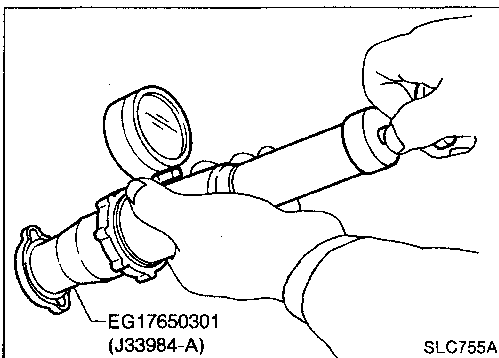

SLC755A

**CHECKING RADIATOR CAP**

To check radiator cap, apply pressure to cap with a tester.

Radiator cap relief pressure:

78 - 98 kPa (0.8 - 1.0 kg/cm<sup>2</sup>, 11 - 14 psi)

Water Pump

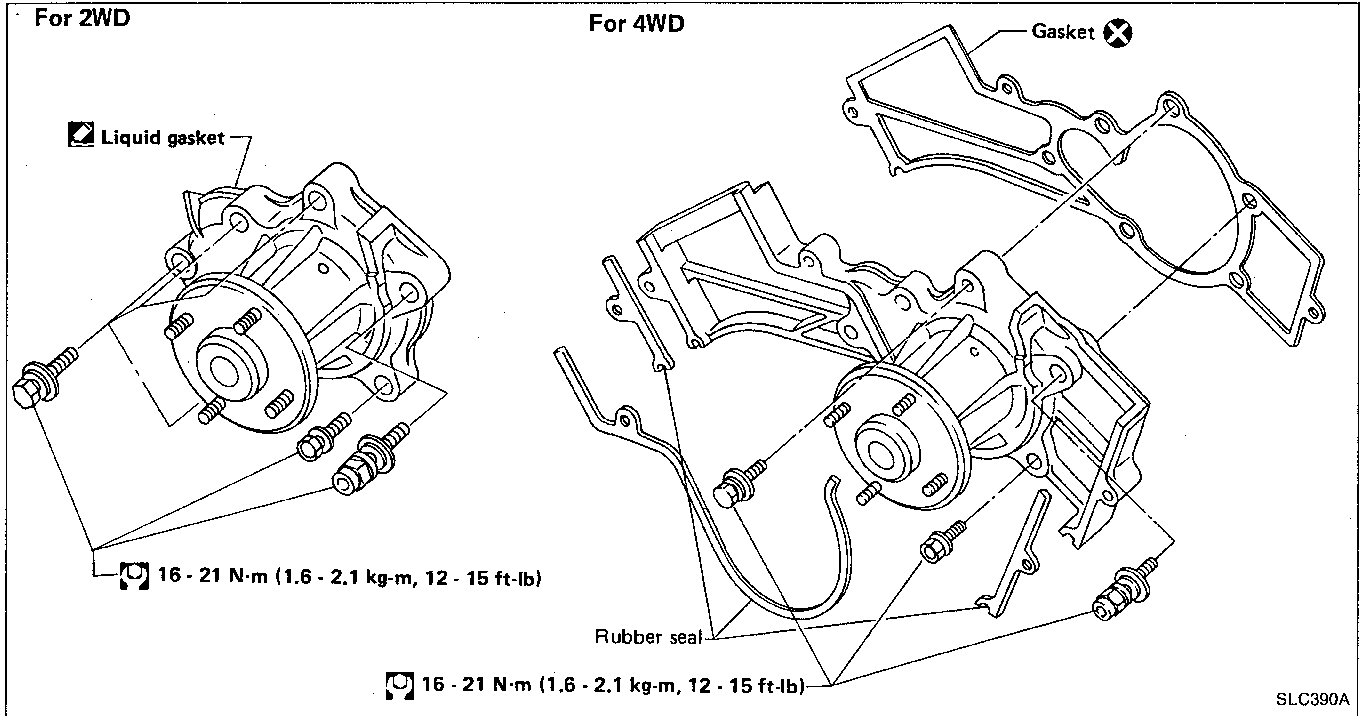

CAUTION:

- When removing water pump assembly, be careful not to get coolant on timing belt.
- Water pump cannot be disassembled and should be replaced as a unit.
- To avoid deforming timing cover, make sure there is adequate clearance between it and the hose clamp.
- After installing water pump, connect hose and clamp securely, then check for leaks using radiator cap tester.

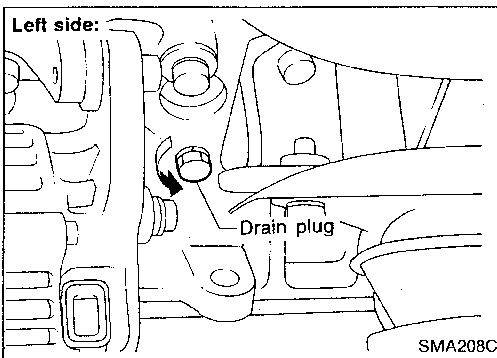
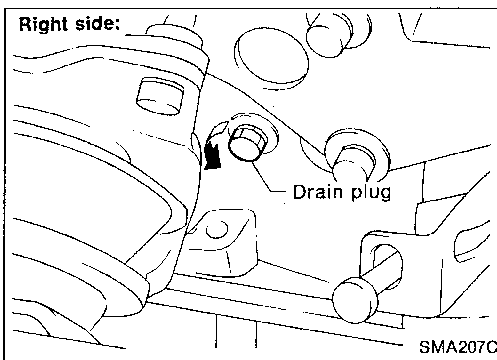

REMOVAL AND INSTALLATION

Drain coolant from drain cocks on both sides of cylinder block and radiator.

GI

MA

EM

LC

EF & EC

FE

CL

SLC390A

MT

AT

TF

PD

FA

RA

BR

ST

BF

HA

EL

IDX

## Water Pump (Cont'd)

### INSPECTION

1. Check for badly rusted or corroded body assembly and vanes.
2. Check for rough operation due to excessive end play.

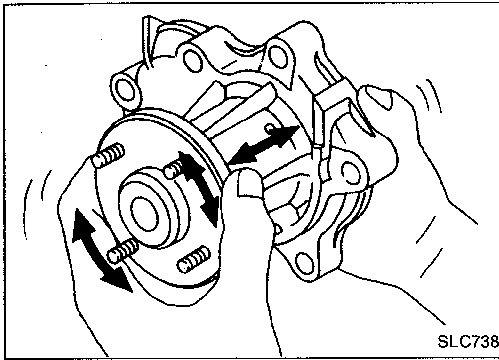

## Thermostat

### INSPECTION

1. Check valve seating condition at ordinary temperatures. It should seat tightly.

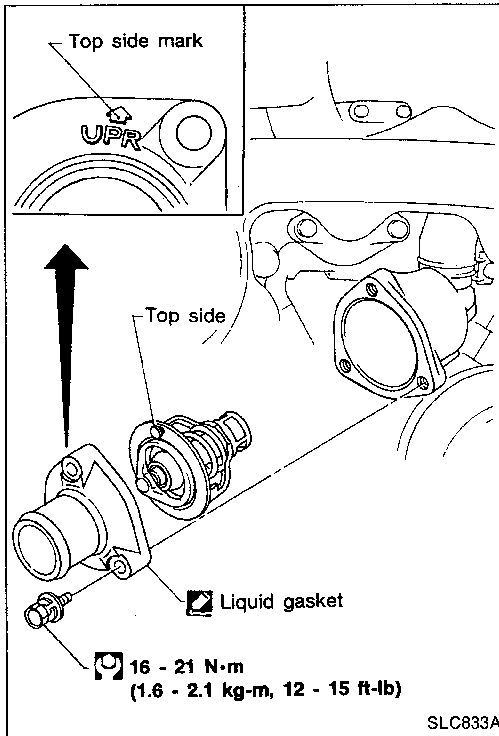

2. Check valve opening temperature and maximum valve lift.

Valve opening temperature	°C (°F)	76.5 (170)
Maximum valve lift	mm/°C (in/°F)	10/90 (0.39/194)

3. Then check if valve is closed at 5°C (9°F) below valve opening temperature.
  - After installation, run engine for a few minutes, and check for leaks.
  - Be careful not to spill coolant over engine compartment. Use a rag to absorb coolant.

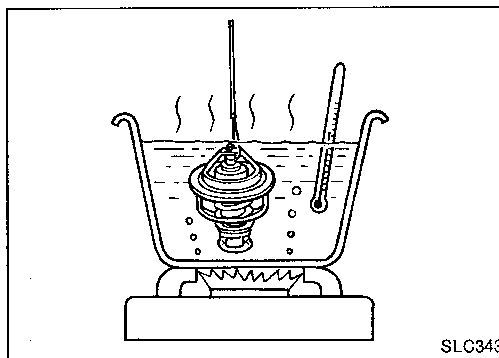

## Radiator

### REMOVAL AND INSTALLATION

1. Remove under cover.
2. Drain coolant from radiator drain cock.
3. Disconnect radiator upper and lower hoses.
4. Remove A/T oil cooler hoses. (A/T model only)
5. Remove radiator lower shroud.
6. Disconnect reservoir tank hose.
7. Remove radiator.



**Radiator (Cont'd)**

8. After repairing or replacing radiator, install any part removed in reverse order of removal.

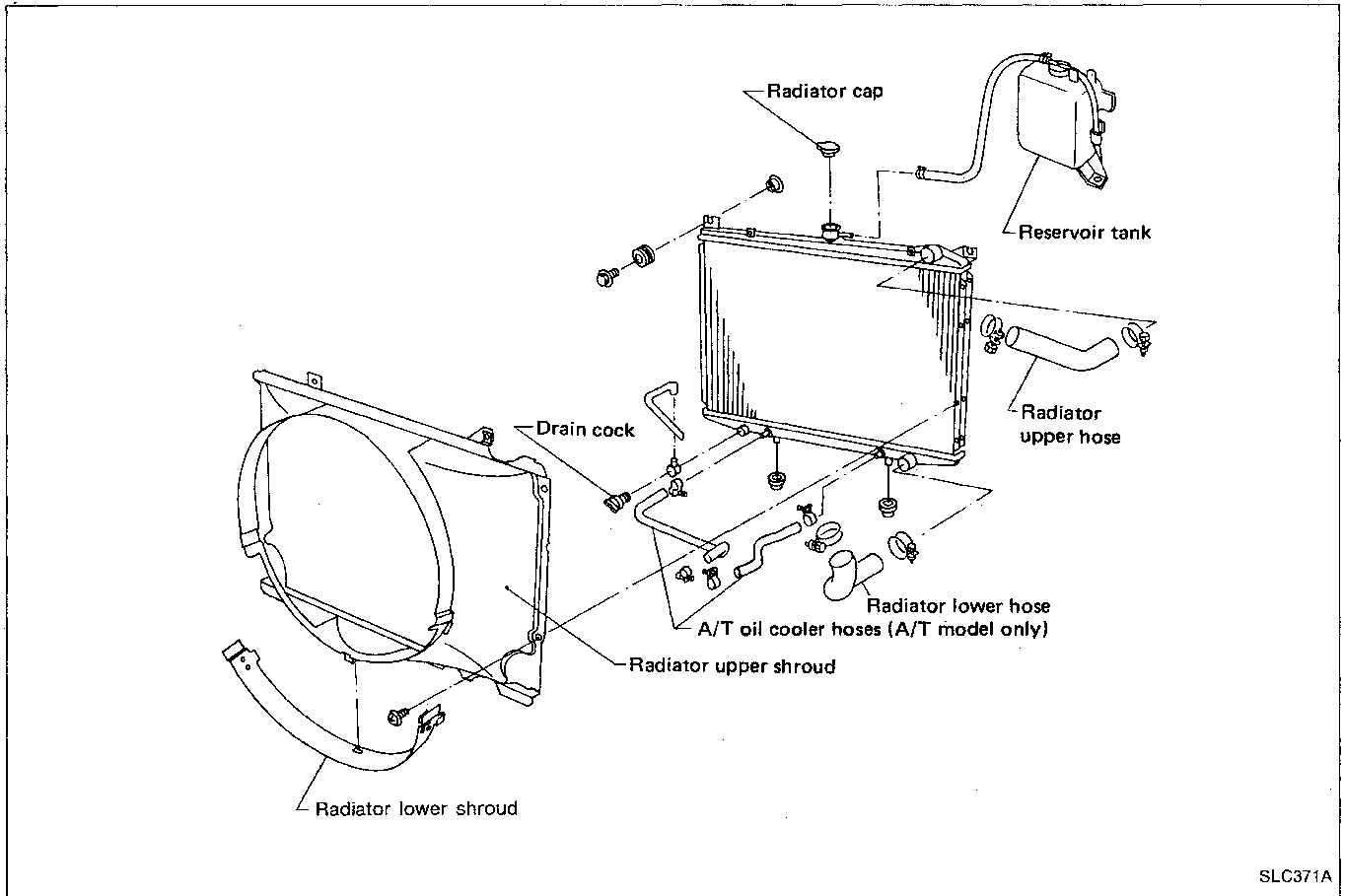

SLC371A

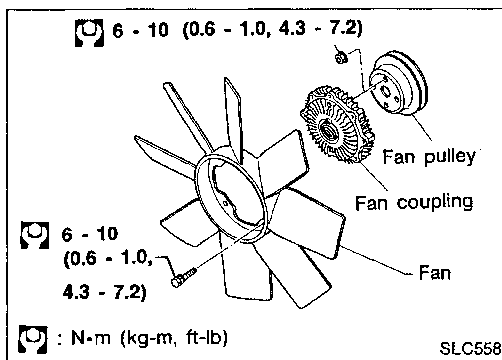

**Cooling Fan**

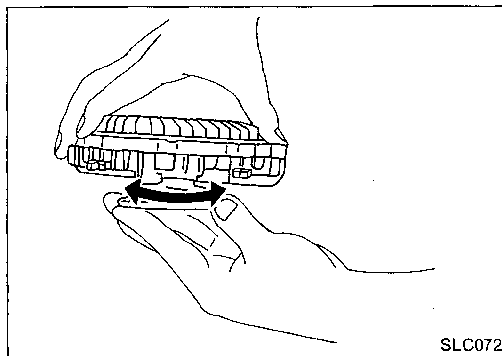

**INSPECTION**

Check fan coupling for oil leakage or bent bimetal.

GI

MA

EM

**LC**

EF & EC

FE

CL

MT

AT

TF

PD

FA

RA

BR

ST

BF

HA

EL

IDX

Lubrication Circuit

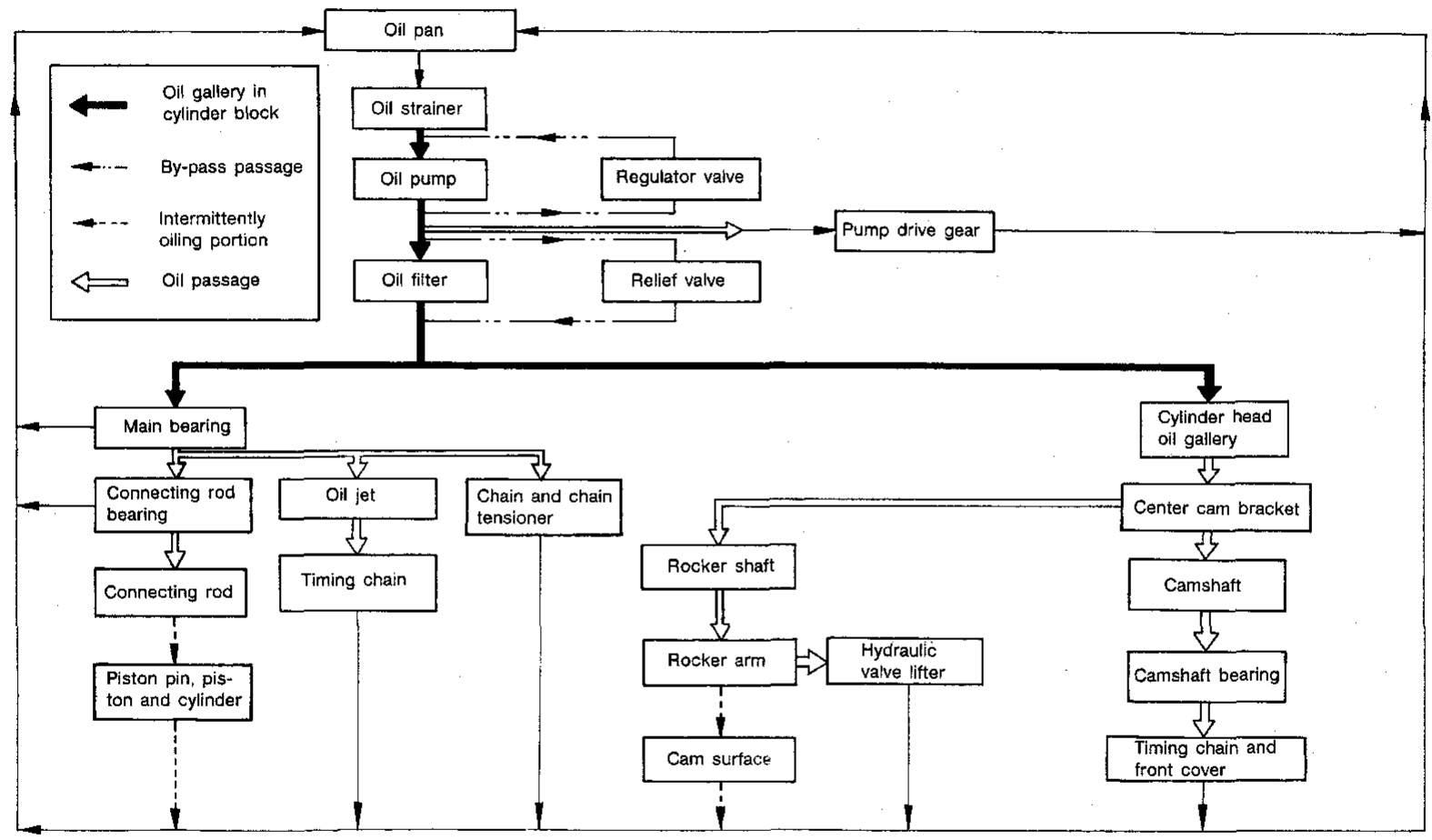

LC-10

SLC182A

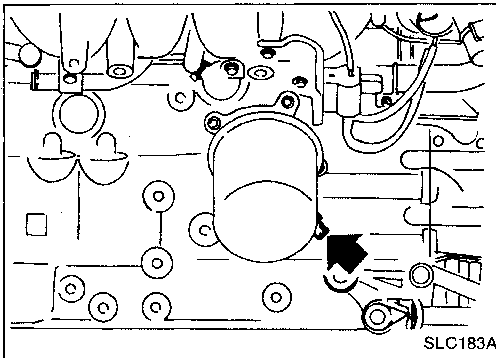

**Oil Pressure Check**

**WARNING:**

- Be careful not to burn yourself, as the engine and oil may hot.
- Oil pressure check should be done in "Neutral" gear position.

1. Check oil level.
2. Remove oil pressure switch.
3. Install pressure gauge.
4. Start engine and warm it up to normal operating temperature.
5. Check oil pressure with engine running under no-load.

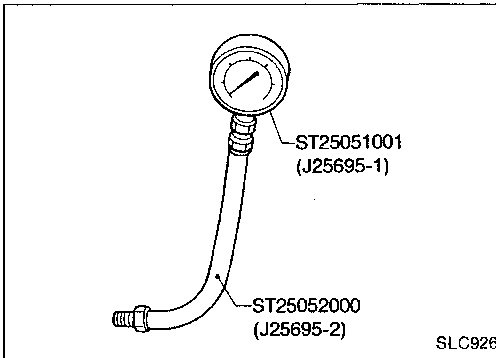

Engine speed rpm	Approximate discharge pressure kPa (kg/cm <sup>2</sup> , psi)
Idle speed	More than 78 (0.8, 11)
3,000	412 - 481 (4.2 - 4.9, 60 - 70)

If difference is extreme, check oil passage and oil pump for oil leaks.

6. Install oil pressure switch with sealant.

**Oil Pump**

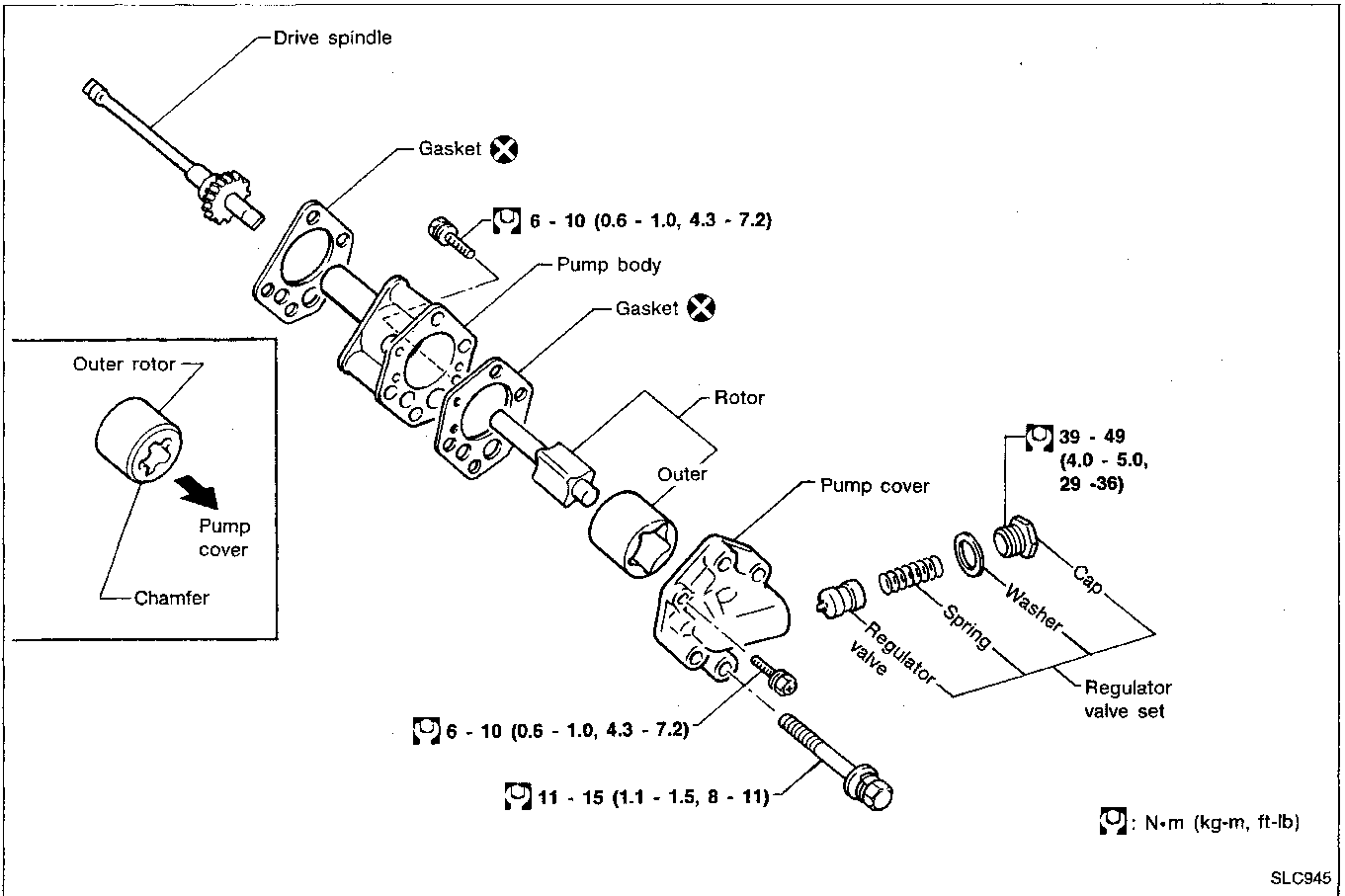

**Oil Pump (Cont'd)**

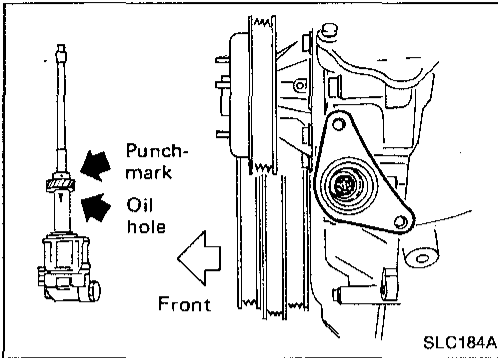

- Always replace with new oil seal and gasket.
- When removing oil pump, turn crankshaft so that No. 1 piston is at TDC on its compression stroke.
- When installing oil pump, align punchmark on drive spindle and oil hole on oil pump.

**REGULATOR VALVE INSPECTION**

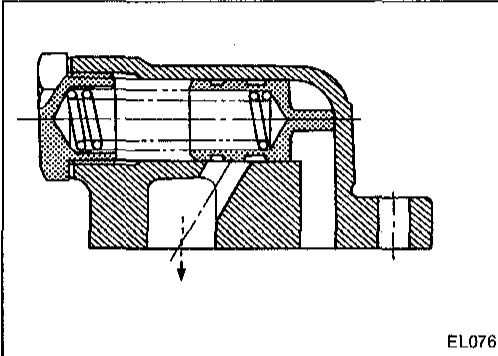

1. Visually inspect components for wear and damage.
2. Check oil pressure regulator valve sliding surface and valve spring.
3. Coat regulator valve with engine oil and check that it falls smoothly into the valve hole by its own weight.

**If damaged, replace regulator valve set or oil pump assembly.**

**OIL PRESSURE RELIEF VALVE INSPECTION**

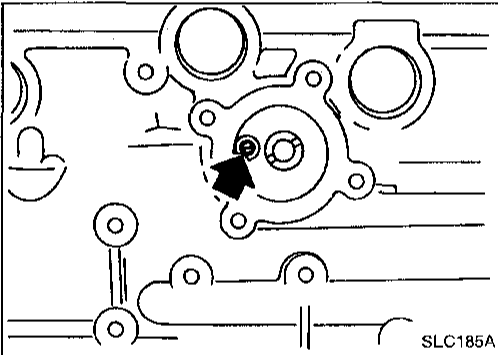

Inspect oil pressure relief valve for movement, cracks and breaks by pushing the ball. If replacement is necessary, remove valve by prying it out with suitable tool. Install a new valve in place by tapping it.

**OIL PUMP INSPECTION**

Using a feeler gauge, check the following clearance.

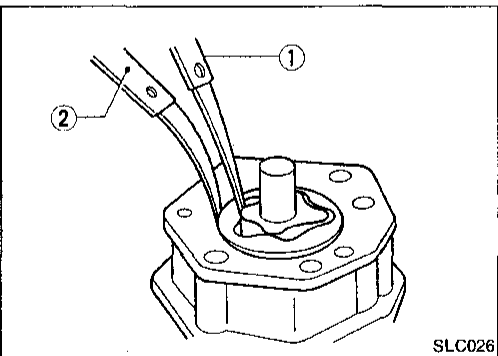

Unit: mm (in)

Rotor tip clearance ①	Less than 0.12 (0.0047)
Outer rotor to body clearance ②	0.15 - 0.21 (0.0059 - 0.0083)
Side clearance (with gasket) ③	0.04 - 0.08 (0.0016 - 0.0031)

**If it exceeds the limit, replace gear set or entire oil pump assembly.**

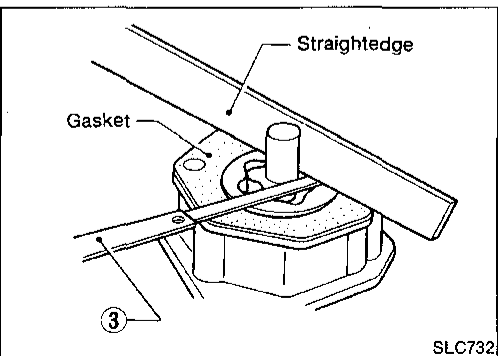

Cooling Circuit

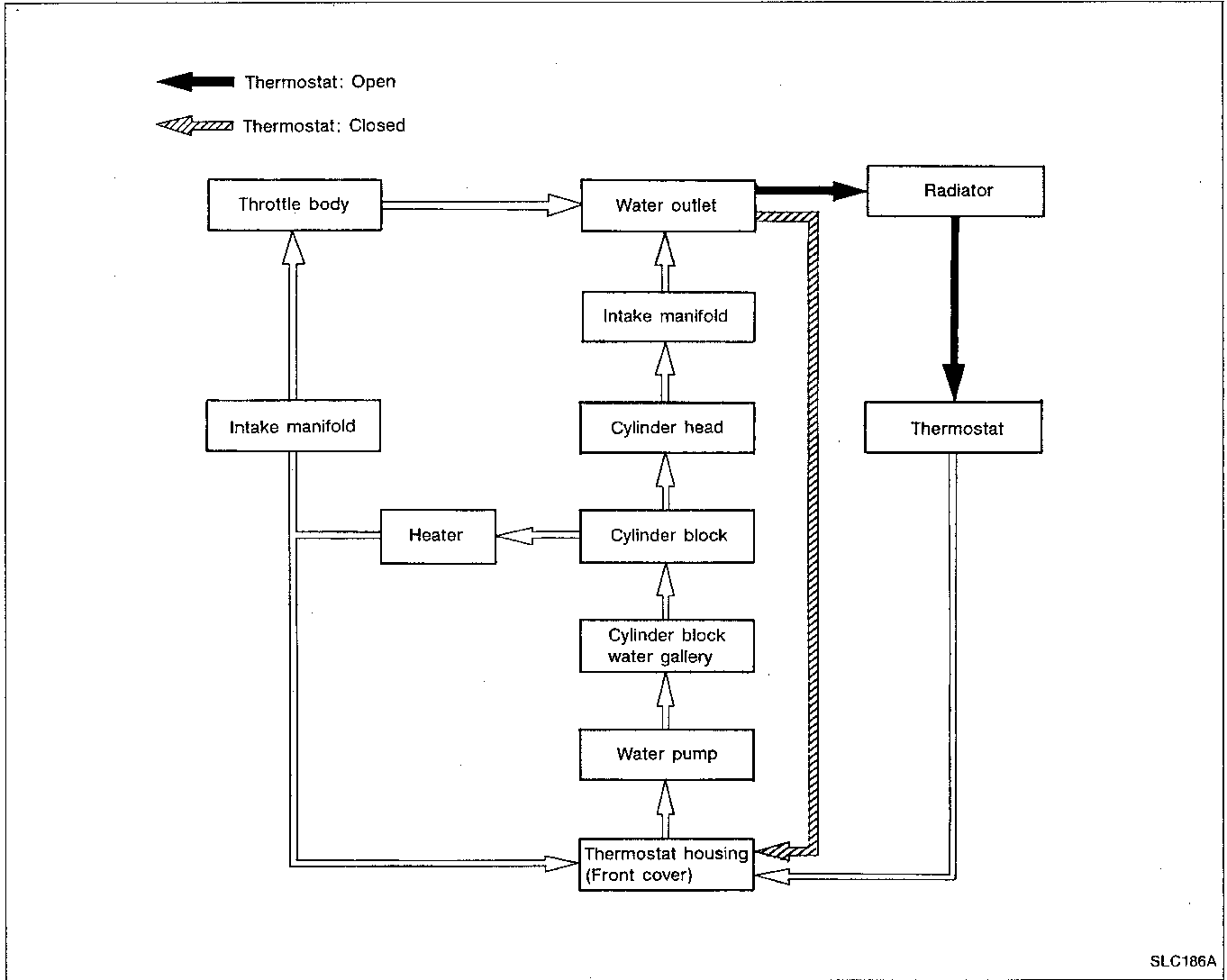

System Check

**WARNING:**

Never remove the radiator cap when the engine is hot; serious burns could be caused by high pressure fluid escaping from the radiator.

Wrap a thick cloth around cap and carefully remove the cap by turning it a quarter turn to allow built-up pressure to escape and then turn the cap all the way off.

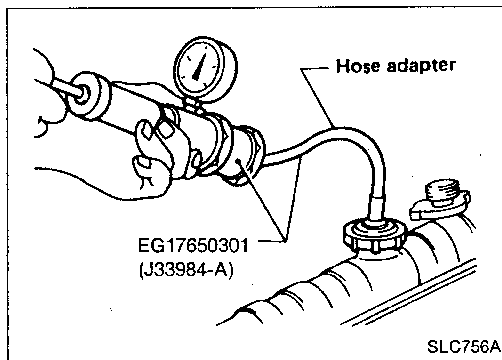

**CHECKING COOLING SYSTEM HOSES**

Check hoses for improper attachment, leaks, cracks, damage, loose connections, chafing and deterioration.

**CHECKING COOLING SYSTEM FOR LEAKS**

To check for leakage, apply pressure to the cooling system with a tester.

Testing pressure: 157 kPa (1.6 kg/cm<sup>2</sup>, 23 psi)

**CAUTION:**

Higher than the specified pressure may cause radiator damage.

GI  
 MA  
 EM  
 LC  
 EF & EC  
 FE  
 CL  
 MT  
 AT  
 TF  
 PD  
 FA  
 RA  
 BR  
 ST  
 BF  
 HA  
 EL  
 IDX

**System Check (Cont'd)**

**CHECKING RADIATOR CAP**

To check radiator cap, apply pressure to cap with a tester.

**Radiator cap relief pressure:**

78 - 98 kPa (0.8 - 1.0 kg/cm<sup>2</sup>, 11 - 14 psi)

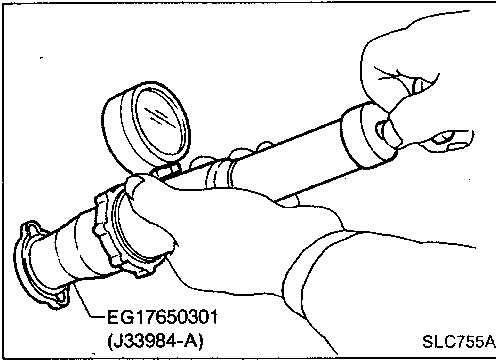

**Water Pump**

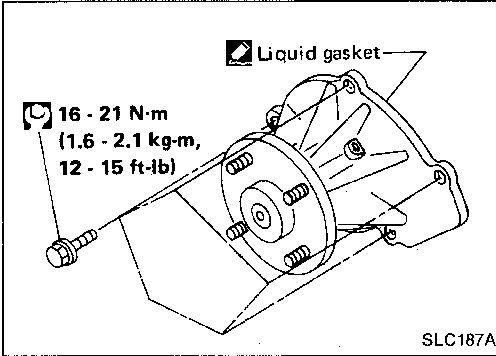

**INSPECTION**

Check for excessive end play and rough operation.

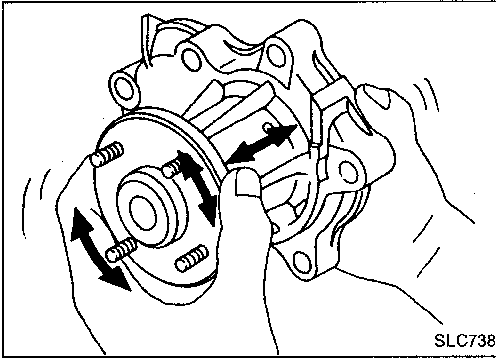

**INSTALLATION**

- Remove liquid gasket from mating surface of pump housing using a scraper.
- **Be sure liquid gasket in grooves is also removed.**
- Remove liquid gasket from mating surface of cylinder block.
- Clean all traces of liquid gasket using white gasoline.
- Cut off tip of nozzle of liquid gasket tube at point shown in figure.
- Use Genuine Liquid Gasket or equivalent.
- Apply a continuous bead of liquid gasket to mating surface of pump housing as shown.

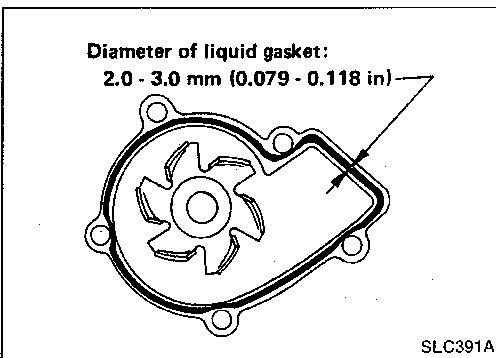
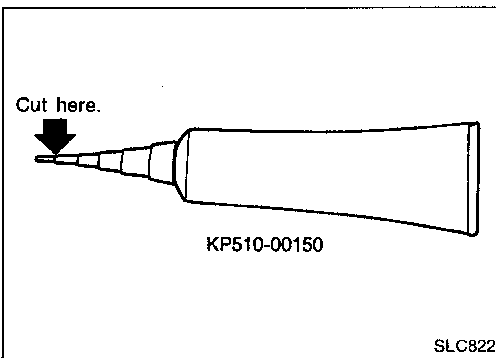

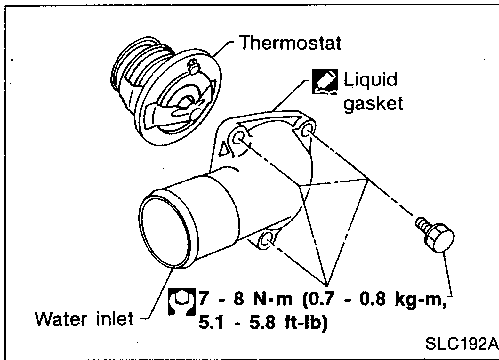

**Thermostat**

**INSPECTION**

1. Check for valve seating condition at ordinary temperatures. It should seat tightly.

GI

MA

EM

LC

EF & EC

FE

CL

MT

AT

TF

PD

FA

RA

BR

ST

BF

HA

EL

IDX

169

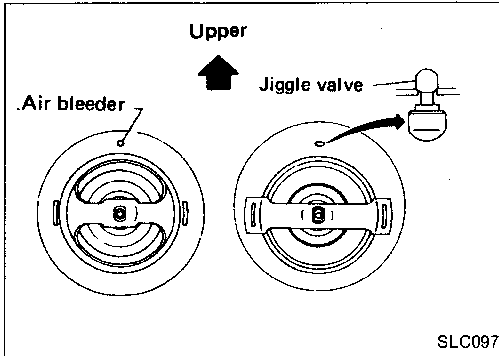

2. Check valve opening temperature and maximum valve lift.

Valve opening temperature	°C (°F)	76.5 (170)
Max. valve lift	mm/°C (in/°F)	8/90 (0.31/194)

3. Then check if valve closes at 5°C (9°F) below valve opening temperature.

- After installation, run engine for a few minutes, and check for leaks.

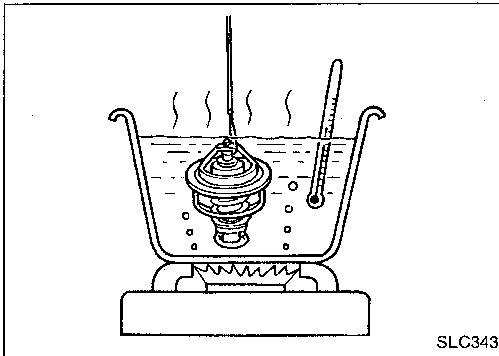

**INSTALLATION**

- Remove liquid gasket from mating surface of thermostat using a scraper.
- Similarly, remove liquid gasket from mating surface of cylinder block.
- Clean all traces of liquid gasket using white gasoline.
- Cut off tip of nozzle of liquid gasket tube at point shown in figure.
- Use Genuine Liquid Gasket or equivalent.

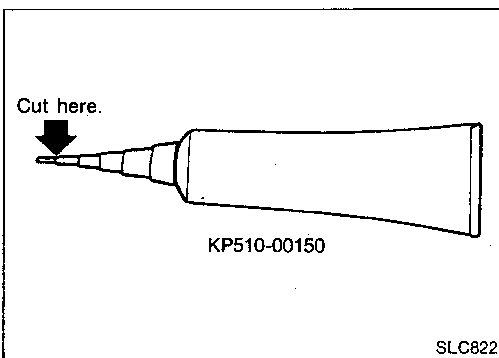

- Apply a continuous bead of liquid gasket to mating surface of water inlet.

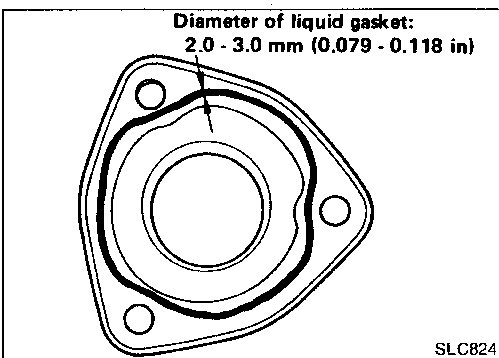

Radiator

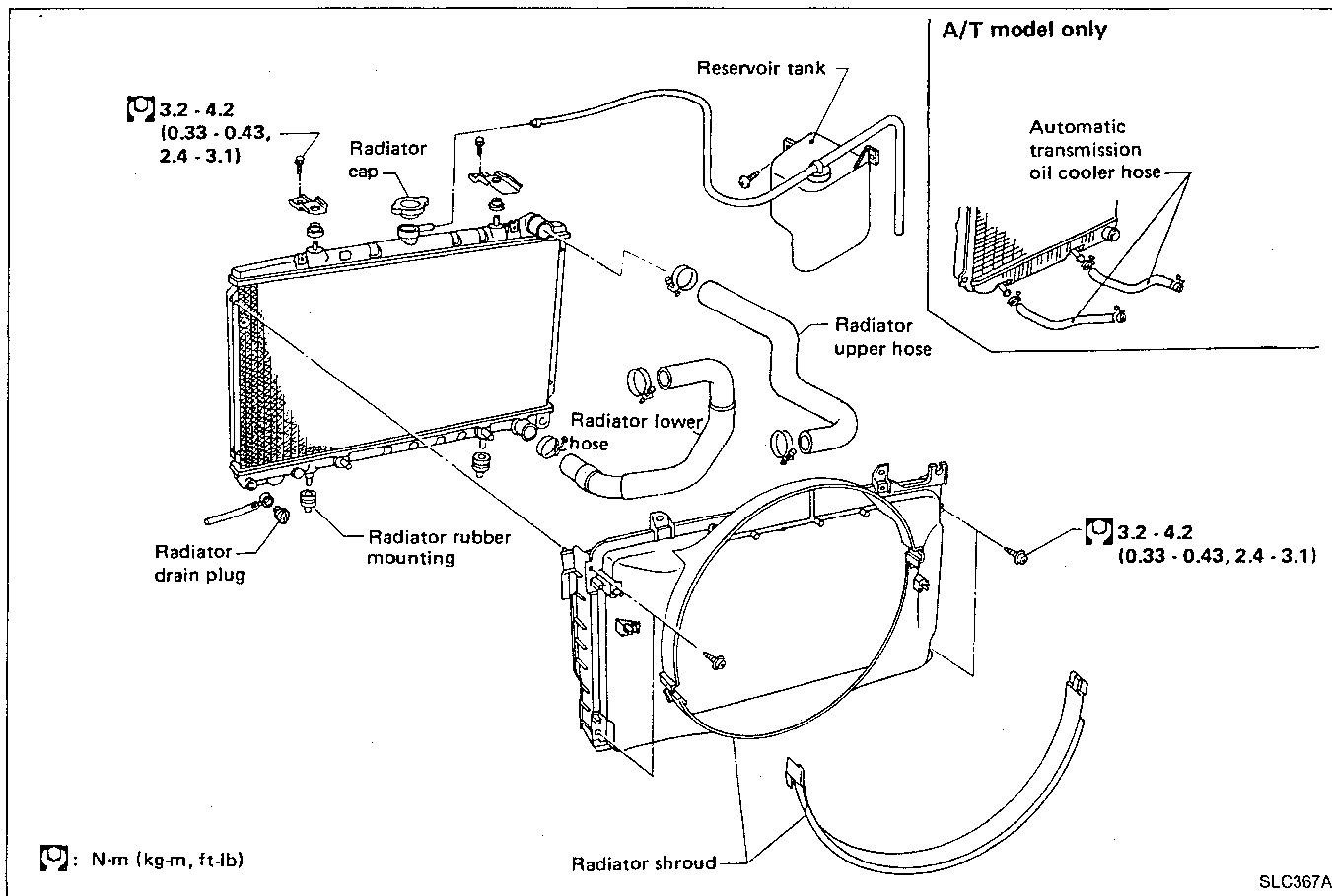

**CAUTION:**  
When filling radiator with coolant, refer to MA section.

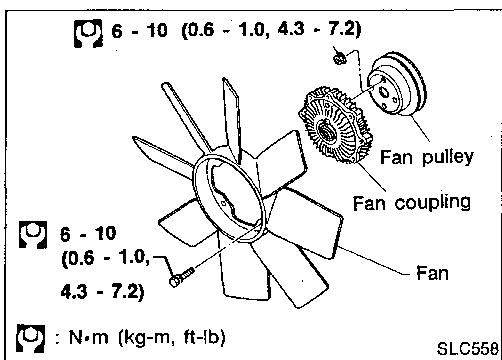

**Cooling Fan  
DISASSEMBLY AND ASSEMBLY**

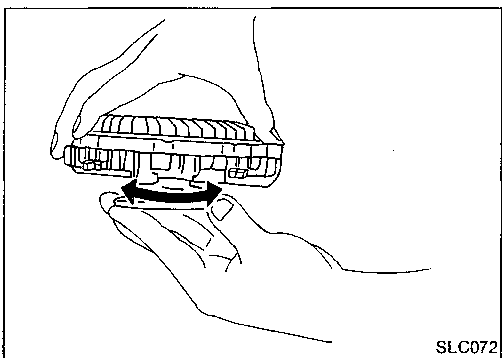

**INSPECTION**  
Check fan coupling for rough operation, oil leakage or bent bimetal.



**Engine Lubrication System (VG30E)**

**Oil pressure check**

Engine speed rpm	Approximate discharge pressure kPa (kg/cm <sup>2</sup> , psi)
Idle speed 3,200	More than 59 (0.6, 9) 363 - 451 (3.7 - 4.6, 53 - 65)

**Oil pump**

		Unit: mm (in)	
Body to outer gear clearance	0.11 - 0.20 (0.0043 - 0.0079)		GI
Inner gear to crescent clearance	0.12 - 0.23 (0.0047 - 0.0091)		MA
Outer gear to crescent clearance	0.21 - 0.32 (0.0083 - 0.0126)		EM
Housing to inner gear clearance	0.05 - 0.09 (0.0020 - 0.0035)		LC
Housing to outer gear clearance	0.05 - 0.11 (0.0020 - 0.0043)		

**Engine Cooling System (VG30E)**

**Thermostat**

Valve opening temperature	°C (°F)	76.5 (170)
Maximum valve lift	mm/°C (in/°F)	10/90 (0.39/194)

**Radiator**

		Unit: kPa (kg/cm <sup>2</sup> , psi)
Cap relief pressure	78 - 98 (0.8 - 1.0, 11 - 14)	FE
Leakage test pressure	157 (1.6, 23)	CL

**Engine Lubrication System (KA24E)**

**Oil pressure check**

Engine speed rpm	Approximate discharge pressure kPa (kg/cm <sup>2</sup> , psi)
Idle speed 3,000	More than 78 (0.8, 11) 412 - 481 (4.2 - 4.9, 60 - 70)

**Oil pump**

		Unit: mm (in)	
Rotor tip clearance	Less than 0.12 (0.0047)		MT
Outer rotor to body clearance	0.15 - 0.21 (0.0059 - 0.0083)		AT
Side clearance (with gasket)	0.04 - 0.08 (0.0016 - 0.0031)		TF

**Engine Cooling System (KA24E)**

**Thermostat**

Valve opening temperature	°C (°F)	76.5 (170)
Max. valve lift	mm/°C (in/°F)	8/90 (0.31/194)

**Radiator**

		Unit: kPa (kg/cm <sup>2</sup> , psi)
Cap relief pressure	78 - 98 (0.8 - 1.0, 11 - 14)	PD
Leakage test pressure	157 (1.6, 23)	FA