

**SAMSUNG**

# Quick Setup Guide



**1-800-SAMSUNG (7267864)**

**Samsung Electronics America, Inc.**  
105 Challenger Road Ridgefield Park, NJ 07660-0511

**Samsung Electronics Canada Inc., Customer Service**  
55 Standish Court Mississauga, Ontario L5R 4B2

**Call center hours of operation (Mon-Sun 9AM-12AM EST).**

To register this product please visit

[www.samsung.com/register](http://www.samsung.com/register).

**LN19B360/LN22B360/LN26B360/  
LN32B360/LN19B361**

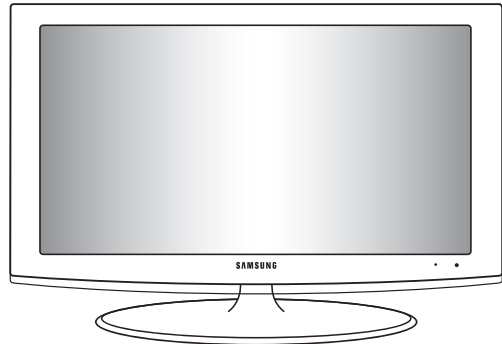

## Rear Panel (LN19B360, LN19B361, LN22B360)

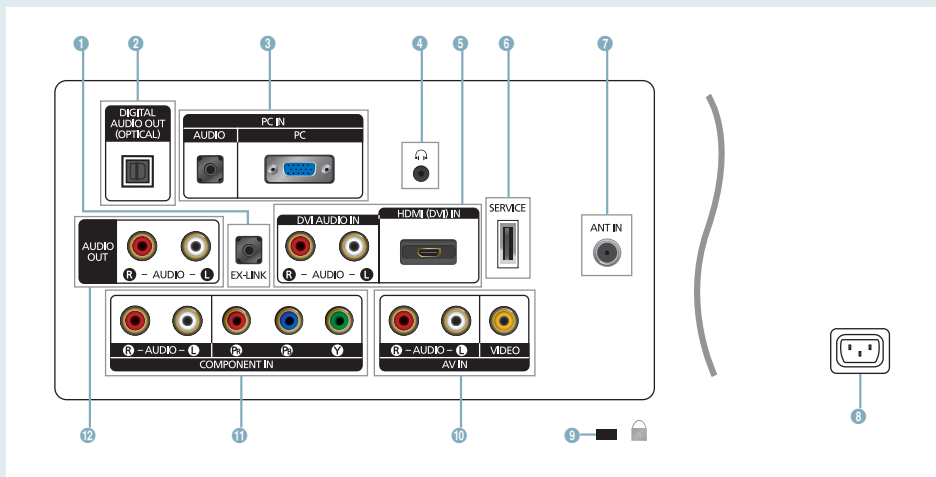

- |                               |   |                          |
|-------------------------------|---|--------------------------|
| 1 EX-LINK                     | 5 HDMI (DVI) IN /<br>DVI AUDIO IN [R-AUDIO-L] | 9 KENSINGTON LOCK        |
| 2 DIGITAL AUDIO OUT (OPTICAL) | 6 SERVICE                                     | 10 AV IN                 |
| 3 PC IN [PC] / [AUDIO]        | 7 ANT IN                                      | 11 COMPONENT IN          |
| 4 (HEADPHONE)                 | 8 POWER INPUT                                 | 12 AUDIO OUT [R-AUDIO-L] |

# Rear Panel (LN26B360, LN32B360)

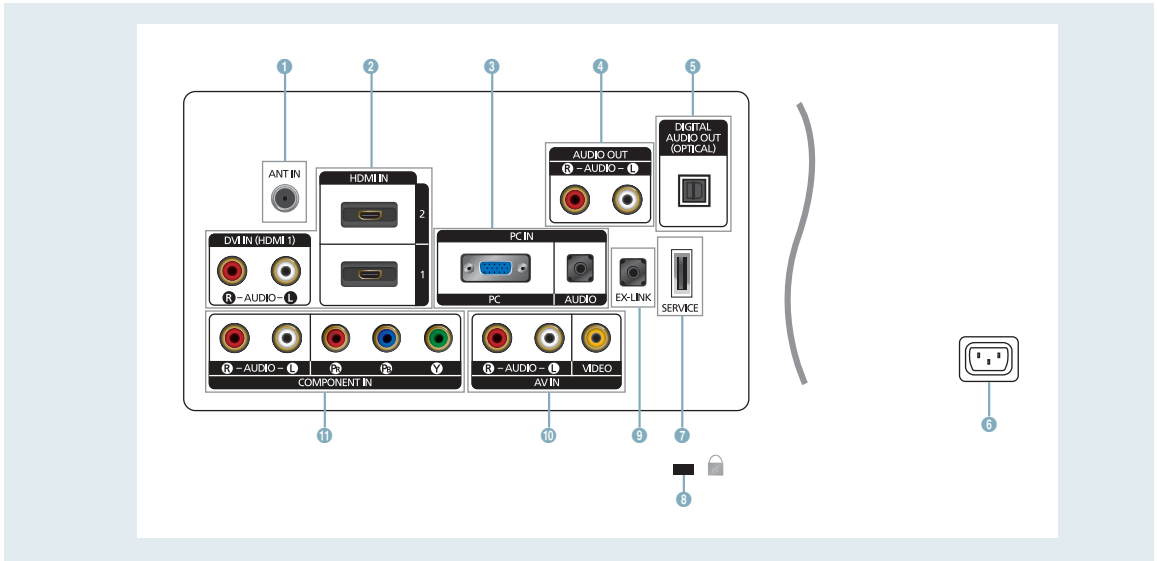

- 1 ANT IN
- 2 HDMI IN 1, 2 / DVI IN (HDMI 1) [R-AUDIO-L]
- 3 PC IN [PC] / [AUDIO]
- 4 AUDIO OUT [R-AUDIO-L]
- 5 DIGITAL AUDIO OUT (OPTICAL)
- 6 POWER INPUT
- 7 SERVICE
- 8 KENSINGTON LOCK
- 9 EX-LINK
- 10 AV IN
- 11 COMPONENT IN

## Video Input Performance Comparison















	HDMI/DVI	Best
	PC/COMPONENT	Better
	VIDEO	Normal

## Audio Output Performance Comparison

	OPTICAL (Digital)	Best
	AUDIO (Analog)	Normal

# Remote Control

See "Remote Control" in the owner's instructions for details.

- 1 POWER**  
Turns the TV on and off.
- 2 NUMERIC BUTTONS**  
Press to change the channel.
- 3 **  
Press to select additional channels (digital and analog) being broadcast by the same station. For example, to select channel '54-3', press '54', then press '' and '3'.
- 4 MUTE **  
Press to temporarily cut off the sound.
- 5 - VOL +**  
Press to increase or decrease the volume.
- 6 CH LIST**  
Used to display Channel Lists on the screen.
- 7 TOOLS**  
Use to quickly select frequently used functions.
- 8 INFO **  
Press to display information on the TV screen.
- 9 COLOR BUTTONS**  
Use these buttons in the Channel list menus etc.
- 10 P.SIZE**  
Picture size selection.
- 11 TV**  
Selects the TV mode directly.
- 12 PRE.CH**  
Tunes to the previous channel.
- 13  CH **  
Press to change channels.
- 14 SOURCE**  
Press to display and select the available video sources.
- 15 FAV.CH**  
Press to switch to your favorite channels.
- 16 MENU **  
Displays the main on-screen menu.
- 17 RETURN **  
Returns to the previous menu.
- 18 UP  / DOWN  / LEFT  / RIGHT  / ENTER **  
Use to select on-screen menu items and change menu values.
- 19 EXIT **  
Press to exit the menu.
- 20 CC**  
Controls the caption decoder.
- 21 MTS**  
Press to choose stereo, mono or Separate Audio Program (SAP broadcast).

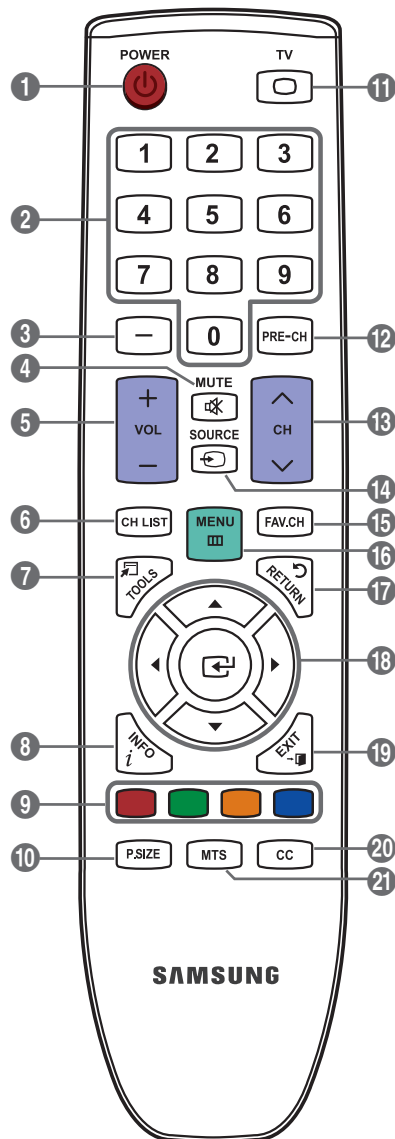

# Connections (LN19B360, LN19B361, LN22B360)

## Connecting a DVD / Blu-ray player / Cable Box / Satellite receiver (Set-Top Box) via HDMI

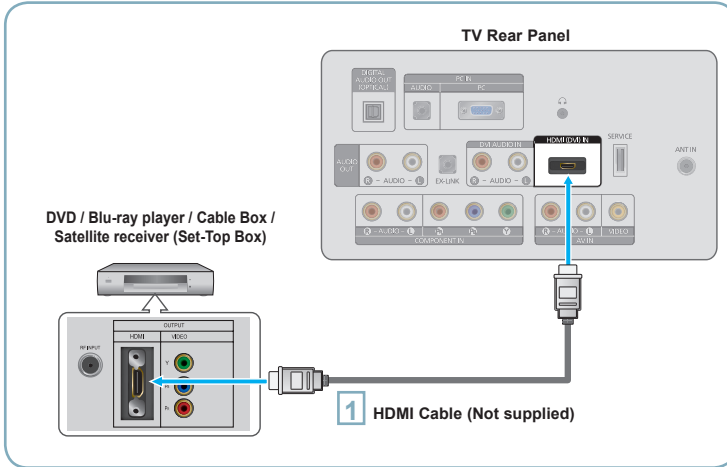

- 1** Connect an HDMI Cable between the HDMI (DVI) IN jack on the TV and the HDMI jack on the DVD / Blu-ray Player or Cable Box / Satellite receiver (Set-Top Box).

### What is HDMI?

- HDMI (High-Definition Multimedia Interface), is an interface that enables the transmission of digital audio and video signals using a single cable.
- The difference between HDMI and DVI is that the HDMI device is smaller in size and has the HDCP (High Bandwidth Digital Copy Protection) coding feature installed.

- > Each DVD / Blu-ray player / Cable Box / Satellite receiver (Set-Top Box) has a different back panel configuration.
- > The TV may not output sound and pictures may be displayed with abnormal color when DVD / Blu-ray player / Cable Box / Satellite receiver (Set-Top Box) supporting HDMI versions older than 1.3 are connected. When connecting an older HDMI cable and there is no sound, connect the HDMI cable to the HDMI (DVI) IN jack and the audio cables to the DVI AUDIO IN [R-AUDIO-L] jacks on the back of the TV. If this happens, contact the company that provided the DVD / Blu-ray player / Cable Box / Satellite receiver (Set-Top Box) to confirm the HDMI version, then request an upgrade.
- > HDMI cables that are not 1.3 may cause annoying flicker or no screen display.

## Connecting a DVD / Blu-ray player / Cable Box / Satellite receiver (Set-Top Box) via DVI

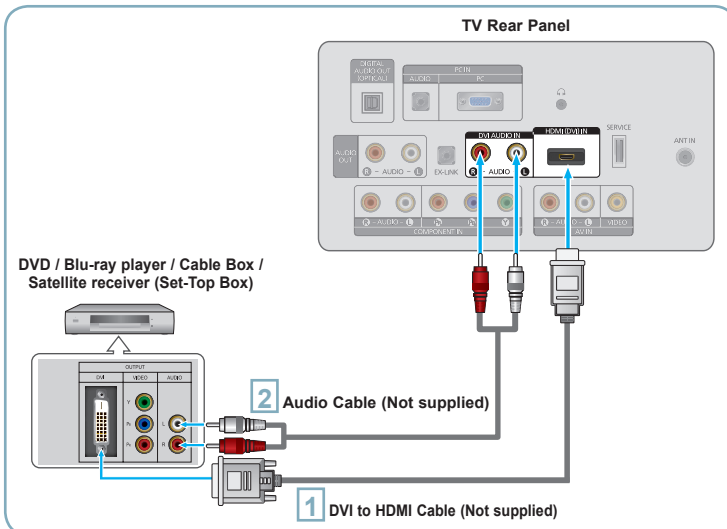

- 1** Connect a DVI to HDMI Cable or DVI-HDMI Adapter between the HDMI (DVI) IN jack on the TV and the DVI jack on the DVD / Blu-ray player / Cable Box / Satellite receiver (Set-Top Box).

- 2** Connect Audio Cables between the DVI AUDIO IN [R-AUDIO-L] jack on the TV and the DVD / Blu-ray player / Cable Box / Satellite receiver (Set-Top Box).

- > Each DVD / Blu-ray player / Cable Box / Satellite receiver (Set-Top Box) has a different back panel configuration.
- > When connecting a DVD / Blu-ray player / Cable Box / Satellite receiver (Set-Top Box), match the color of the connection terminal to the cable.

## Connecting a DVD / Blu-ray player / Cable Box / Satellite receiver (Set-Top Box) via Component cables

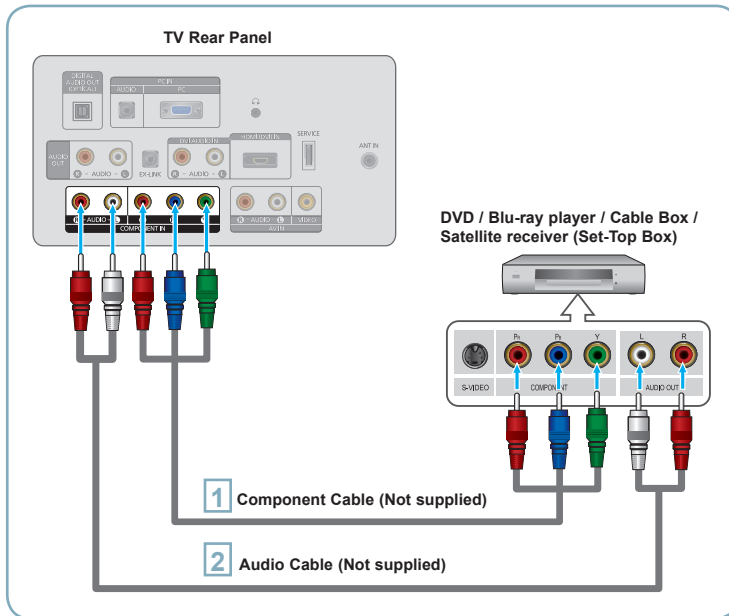

**1** Connect a Component Cable between the COMPONENT IN [Y, Pb, Pr] jacks on the TV and the COMPONENT [Y, Pb, Pr] jacks on the DVD / Blu-ray player / Cable Box / Satellite receiver (Set-Top Box).

**2** Connect Audio Cables between the COMPONENT IN [R-AUDIO-L] jacks on the TV and the AUDIO OUT jacks on the DVD / Blu-ray player / Cable Box / Satellite receiver (Set-Top Box).

- Component video separates the video into Y (Luminance (brightness)), Pb (Blue) and Pr (Red) for enhanced video quality. Be sure to match the component video and audio connections. For example, if connecting a Component video cable to COMPONENT IN, connect the audio cable to COMPONENT IN also.
- Each DVD / Blu-ray player / Cable Box / Satellite receiver (Set-Top Box) has a different back panel configuration.
- When connecting a DVD / Blu-ray player / Cable Box / Satellite receiver (Set-Top Box), match the color of the connection terminal to the cable.

## Connecting a VCR

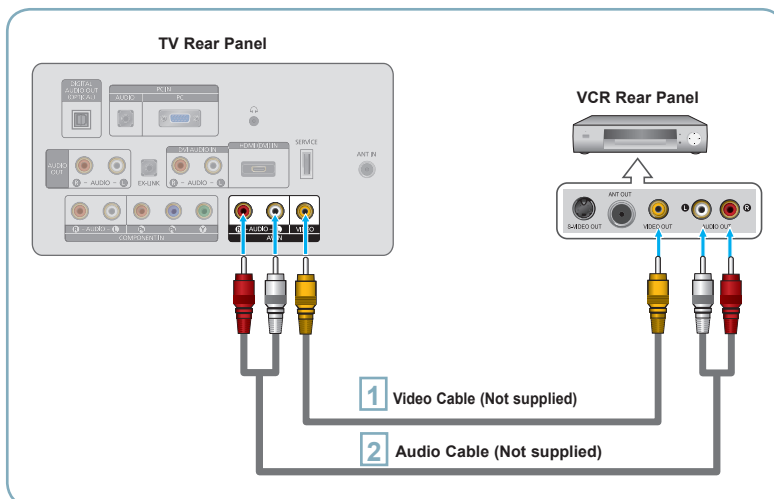

**1** Connect a Video Cable between the AV IN [VIDEO] jack on the TV and the VIDEO OUT jack on the VCR.

**2** Connect Audio Cables between the AV IN [R-AUDIO-L] jacks on the TV and the AUDIO OUT jacks on the VCR.

- If you have a 'mono' (non-stereo) VCR, use a Y-connector (not supplied) to connect to the right and left audio input jacks of the TV. Alternatively, connect the cable to the 'R' jack. If your VCR is stereo, you must connect two cables.
- Each VCR has a different back panel configuration.
- When connecting a VCR, match the color of the connection terminal to the cable.

## Connecting a Digital Audio System

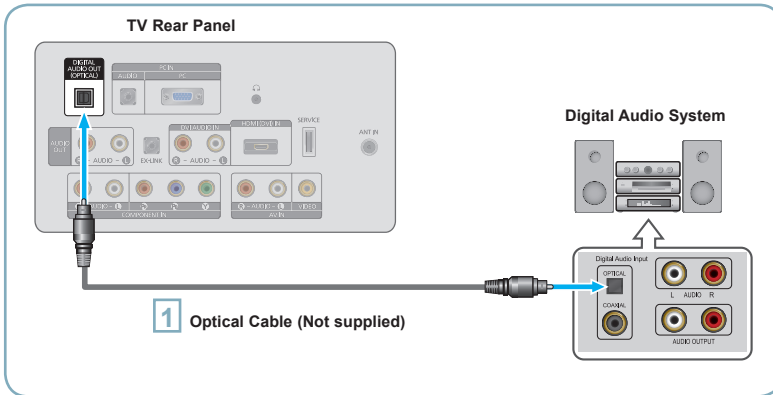

- 1 Connect an Optical Cable between the DIGITAL AUDIO OUT (OPTICAL) jacks on the TV and the Digital Audio Input jacks on the Digital Audio System.

- When a Digital Audio System is connected to the DIGITAL AUDIO OUT (OPTICAL) jack: Decrease the volume of the TV and adjust the volume level with the system's volume control.
- 5.1CH audio is possible when the TV is connected to an external device supporting 5.1CH.
- Each Digital Audio System has a different back panel configuration.
- When the Home Theater receiver is set to On, you can hear sound output from the TV's Optical jack. When the TV is displaying a DTV(air) signal, the TV will send out 5.1 channel sound to the Home theater receiver. When the source is a digital component such as a DVD / Blu-ray player / Cable Box / Satellite receiver (Set-Top Box) and is connected to the TV via HDMI, only 2 channel sound will be heard from the Home Theater receiver. If you want to hear 5.1 channel audio, connect the digital audio out jack on DVD / Blu-ray player / Cable Box / Satellite receiver (Set-Top Box) directly to an Amplifier or Home Theater, not the TV.

## Connecting an Amplifier / DVD Home Theater

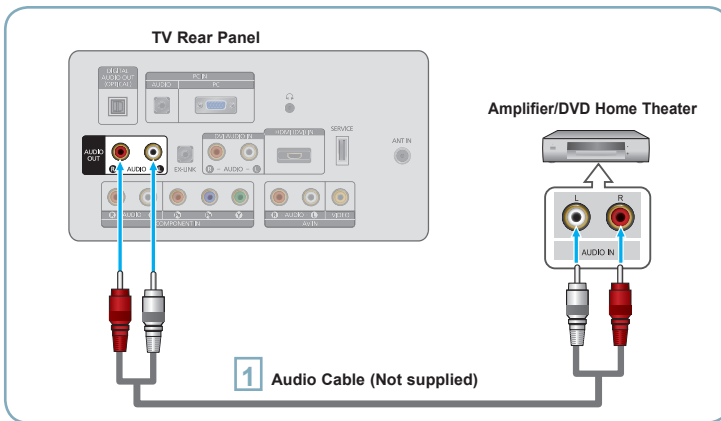

- 1 Connect Audio Cables between the AUDIO OUT [R-AUDIO-L] jacks on the TV and Audio Input jacks on the Amplifier / DVD Home Theater.

- When an audio amplifier is connected to the AUDIO OUT [R-AUDIO-L] jacks: Decrease the volume of the TV and adjust the volume level with the Amplifier's volume control.
- Each Amplifier/DVD Home Theater has a different back panel configuration.
- When connecting an Amplifier/DVD Home Theater, match the color of the connection terminal to the cable.

# Connecting a Camcorder

## Using a Video Cable

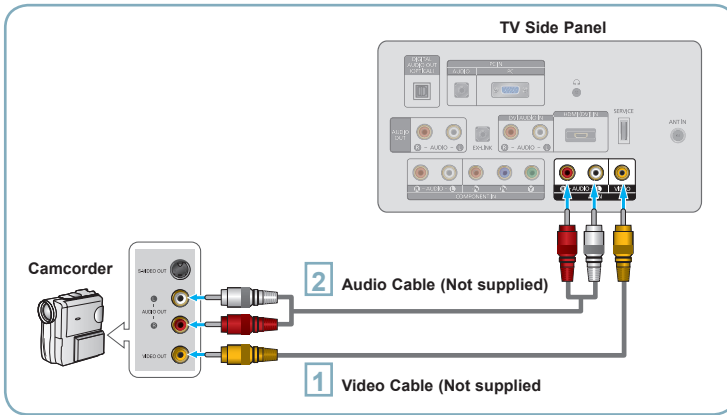

**1** Connect a Video Cable between the AV IN [VIDEO] jack on the TV and the VIDEO OUT jack on the camcorder.

**2** Connect Audio Cables between the AV IN [R-AUDIO-L] jacks on the TV and the AUDIO OUT jacks on the camcorder.

- Each Camcorder has a different back panel configuration.
- When connecting a Camcorder, match the color of the connection terminal to the cable.

## Using an HDMI Cable

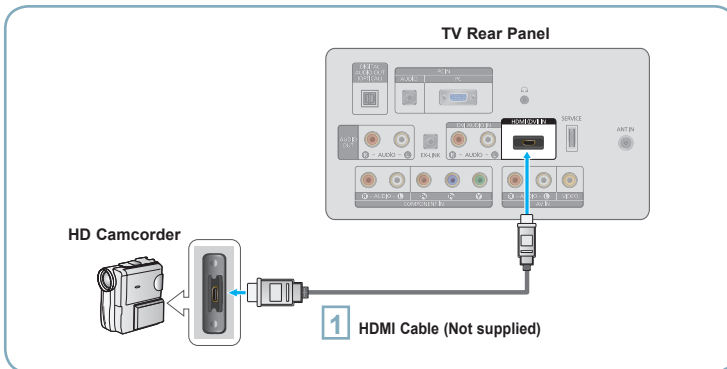

**1** Connect an HDMI Cable between the HDMI (DVI) IN jack on the TV and the HDMI OUT jack on the camcorder.

# Connecting a PC

## Using a D-Sub Cable

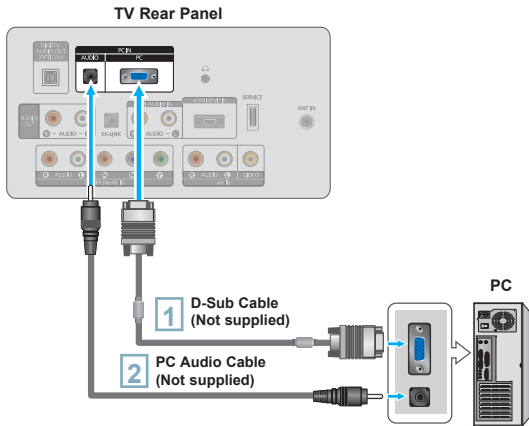

## Using a D-Sub Cable

- 1 Connect a D-Sub Cable between PC IN [PC] connector on the TV and the PC output connector on your computer.
  - 2 Connect a PC Audio Cable between the PC IN [AUDIO] jack on the TV and the Audio Out jack of the sound card on your computer.
- > When connecting a PC, match the color of the connection terminal to the cable.

## Using an HDMI/DVI Cable

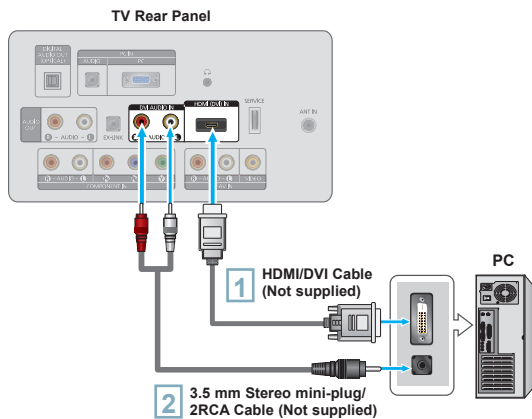

## Using an HDMI/DVI Cable

- 1 Connect an HDMI/DVI cable between the HDMI (DVI) IN jack on the TV and the PC output jack on your computer.
- 2 Connect a 3.5 mm Stereo miniplug / 2RCA Cable between the DVI AUDIO IN [R-AUDIO-L] jack on the TV and the Audio Out jack of the sound card on your computer.

## Using an HDMI Cable

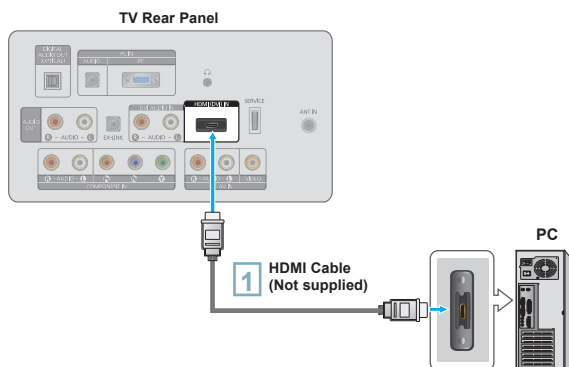

## Using an HDMI Cable

- 1 Connect an HDMI cable between the HDMI (DVI) IN jack on the TV and the PC output jack on your computer.
- > Each PC has a different back panel configuration.



## Connections (LN26B360, LN32B360)

### Connecting a DVD / Blu-ray player / Cable Box / Satellite receiver (Set-Top Box) via HDMI

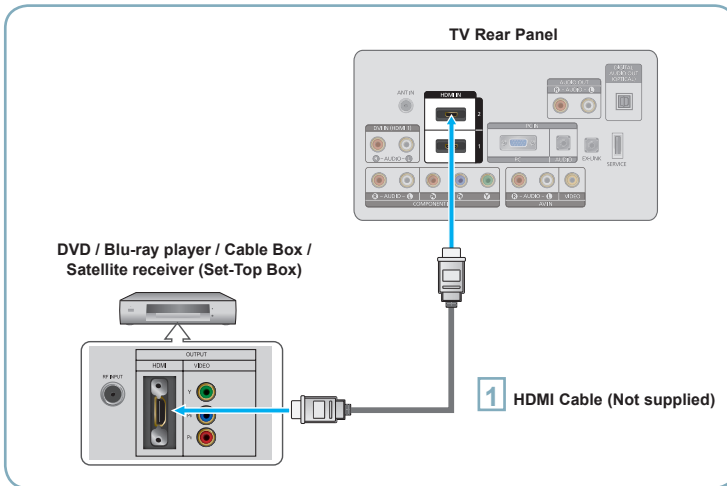

- 1** Connect an HDMI Cable between the HDMI IN (1 or 2) jack on the TV and the HDMI jack on the DVD Player or Cable Box / Satellite receiver (Set-Top Box).

#### What is HDMI?

- HDMI (High-Definition Multimedia Interface), is an interface that enables the transmission of digital audio and video signals using a single cable.
- The difference between HDMI and DVI is that the HDMI device is smaller in size and has the HDCP (High Bandwidth Digital Copy Protection) coding feature installed.

- Each DVD / Blu-ray player / Cable Box / Satellite receiver (Set-Top Box) has a different back panel configuration.
- The TV may not output sound and pictures may be displayed with abnormal color when DVD / Blu-ray player / Cable Box / Satellite receiver (Set-Top Box) supporting HDMI versions older than 1.3 are connected. When connecting an older HDMI cable and there is no sound, connect the HDMI cable to the HDMI IN 1 jack and the audio cables to the DVI IN (HDMI 1) [R-AUDIO-L] jacks on the back of the TV. If this happens, contact the company that provided the DVD / Blu-ray player / Cable Box / Satellite receiver (Set-Top Box) to confirm the HDMI version, then request an upgrade.
- HDMI cables that are not 1.3 may cause annoying flicker or no screen display.

### Connecting a DVD / Blu-ray player / Cable Box / Satellite receiver (Set-Top Box) via DVI

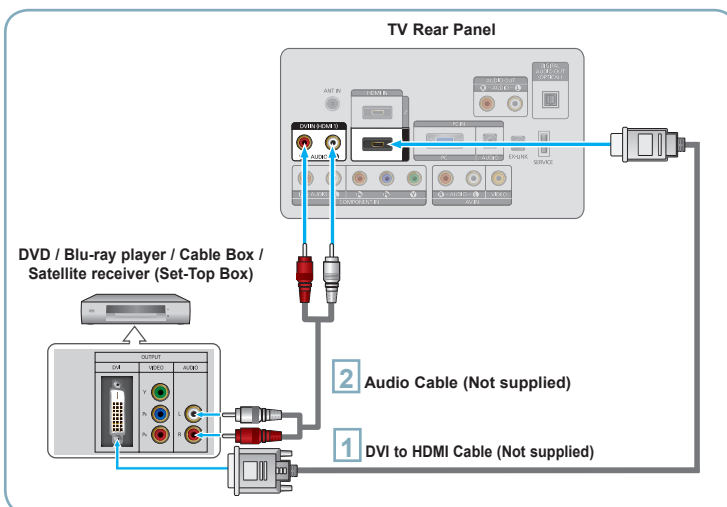

- 1** Connect a DVI to HDMI Cable or DVI-HDMI Adapter between the HDMI IN 1 jack on the TV and the DVI jack on the DVD / Blu-ray player / Cable Box / Satellite receiver (Set-Top Box).
- 2** Connect Audio Cables between the DVI IN (HDMI 1) [R-AUDIO-L] jack on the TV and the DVD / Blu-ray player / Cable Box / Satellite receiver (Set-Top Box).

- Each DVD / Blu-ray player / Cable Box / Satellite receiver (Set-Top Box) has a different back panel configuration.
- When connecting a DVD / Blu-ray player / Cable Box / Satellite receiver (Set-Top Box), match the color of the connection terminal to the cable.
- When using an HDMI / DVI cable connection, you must use the HDMI IN 1 jack.

## Connecting a DVD / Blu-ray player / Cable Box / Satellite receiver (Set-Top Box) via Component cables

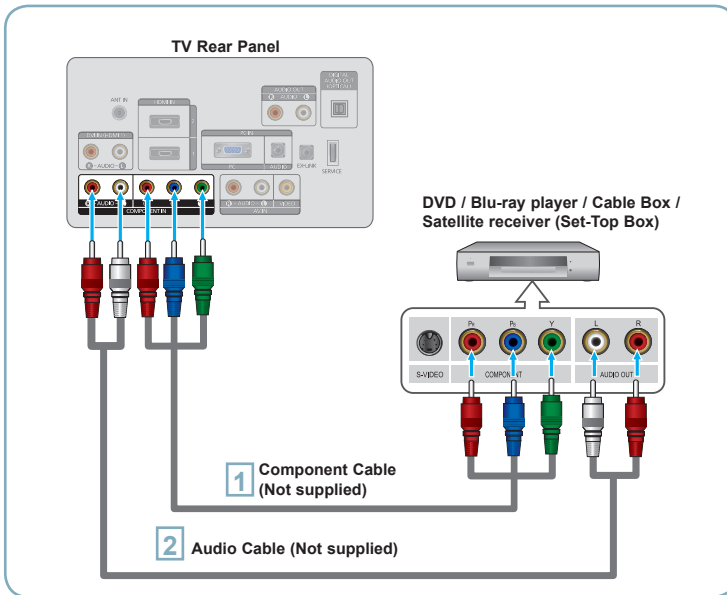

**1** Connect a Component Cable between the COMPONENT IN [Y, Pb, Pr] jacks on the TV and the COMPONENT [Y, Pb, Pr] jacks on the DVD / Blu-ray player / Cable Box / Satellite receiver (Set-Top Box).

**2** Connect Audio Cables between the COMPONENT IN [R-AUDIO-L] jacks on the TV and the AUDIO OUT jacks on the DVD / Blu-ray player / Cable Box / Satellite receiver (Set-Top Box).

- Component video separates the video into Y (Luminance (brightness)), Pb (Blue) and Pr (Red) for enhanced video quality. Be sure to match the component video and audio connections. For example, if connecting a Component video cable to COMPONENT IN, connect the audio cable to COMPONENT IN also.
- Each DVD / Blu-ray player / Cable Box / Satellite receiver (Set-Top Box) has a different back panel configuration.
- When connecting a DVD / Blu-ray player / Cable Box / Satellite receiver (Set-Top Box), match the color of the connection terminal to the cable.

## Connecting a VCR

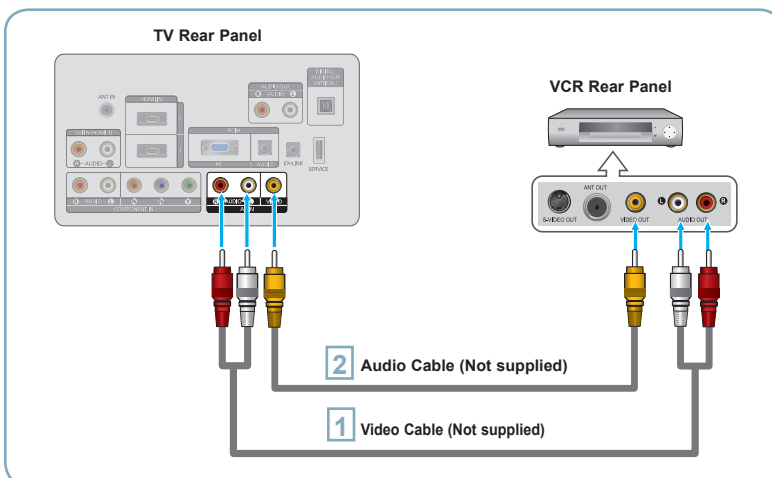

**1** Connect a Video Cable between the AV IN [VIDEO] jack on the TV and the VIDEO OUT jack on the VCR.

**2** Connect Audio Cables between the AV IN [R-AUDIO-L] jacks on the TV and the AUDIO OUT jacks on the VCR.

- If you have a 'mono' (non-stereo) VCR, use a Y-connector (not supplied) to connect to the right and left audio input jacks of the TV. Alternatively, connect the cable to the 'R' jack. If your VCR is stereo, you must connect two cables.
- Each VCR has a different back panel configuration.
- When connecting a VCR, match the color of the connection terminal to the cable.

## Connecting a Digital Audio System

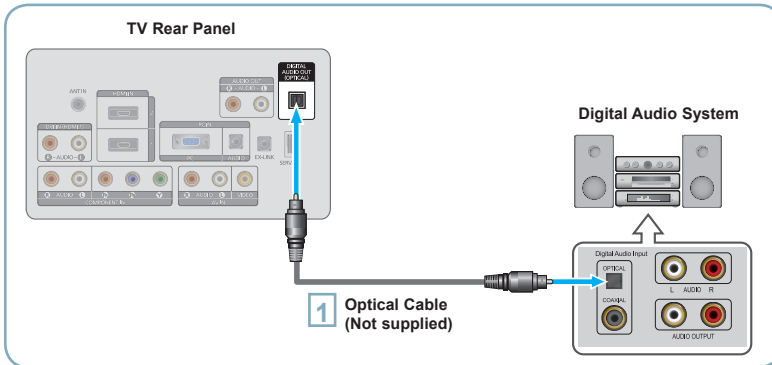

- 1 Connect an Optical Cable between the DIGITAL AUDIO OUT (OPTICAL) jacks on the TV and the Digital Audio Input jacks on the Digital Audio System.

- When a Digital Audio System is connected to the DIGITAL AUDIO OUT (OPTICAL) jack: Decrease the volume of the TV and adjust the volume level with the system's volume control.
- 5.1CH audio is possible when the TV is connected to an external device supporting 5.1CH.
- Each Digital Audio System has a different back panel configuration.
- When the Home Theater receiver is set to On., you can hear sound output from the TV's Optical jack. When the TV is displaying a DTV(air) signal, the TV will send out 5.1 channel sound to the Home theater receiver. When the source is a digital component such as a DVD / Blu-ray player / Cable Box / Satellite receiver (Set-Top Box) and is connected to the TV via HDMI, only 2 channel sound will be heard from the Home Theater receiver. If you want to hear 5.1 channel audio, connect the digital audio out jack on DVD / Blu-ray player / Cable Box / Satellite receiver (Set-Top Box) directly to an Amplifier or Home Theater, not the TV.

## Connecting an Amplifier / DVD Home Theater

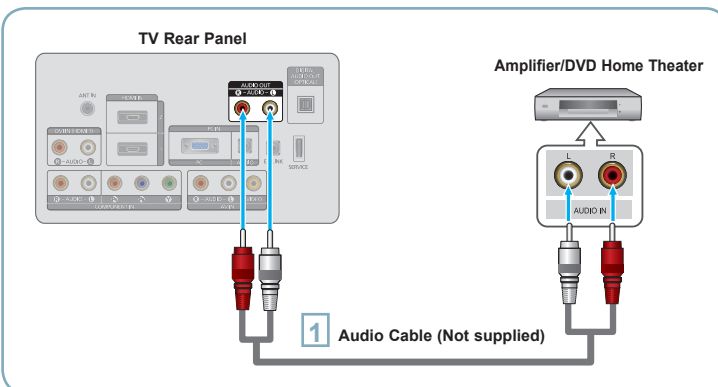

- 1 Connect Audio Cables between the AUDIO OUT [R-AUDIO-L] jacks on the TV and Audio Input jacks on the Amplifier / DVD Home Theater.

- When an audio amplifier is connected to the AUDIO OUT [R-AUDIO-L] jacks: Decrease the volume of the TV and adjust the volume level with the Amplifier's volume control.
- Each Amplifier/DVD Home Theater has a different back panel configuration.
- When connecting an Amplifier/DVD Home Theater, match the color of the connection terminal to the cable.

# Connecting a Camcorder

## Using a Video Cable

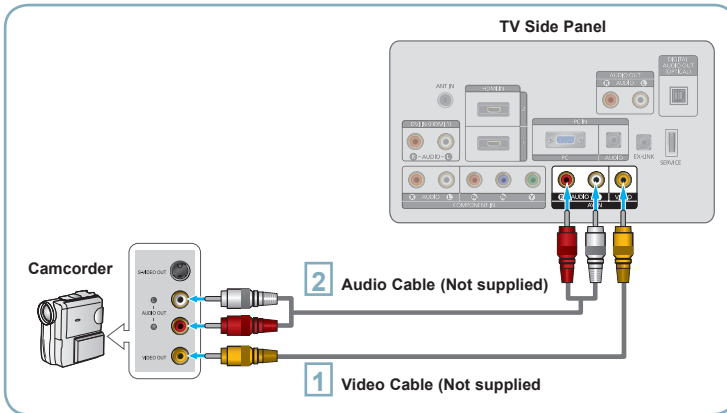

**1** Connect a Video Cable between the AV IN [VIDEO] jack on the TV and the VIDEO OUT jack on the camcorder.

**2** Connect Audio Cables between the AV IN [R-AUDIO-L] jacks on the TV and the AUDIO OUT jacks on the camcorder.

- Each Camcorder has a different back panel configuration.
- When connecting a Camcorder, match the color of the connection terminal to the cable.

## Using an HDMI Cable

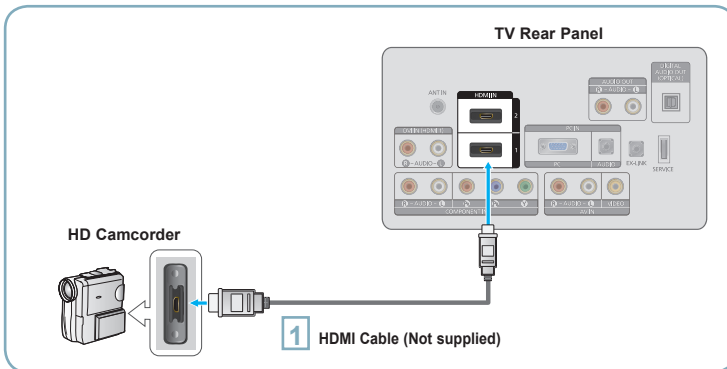

**1** Connect an HDMI Cable between the HDMI IN (1 or 2) IN jack on the TV and the HDMI OUT jack on the camcorder.

# Connecting a PC

## Using a D-Sub Cable

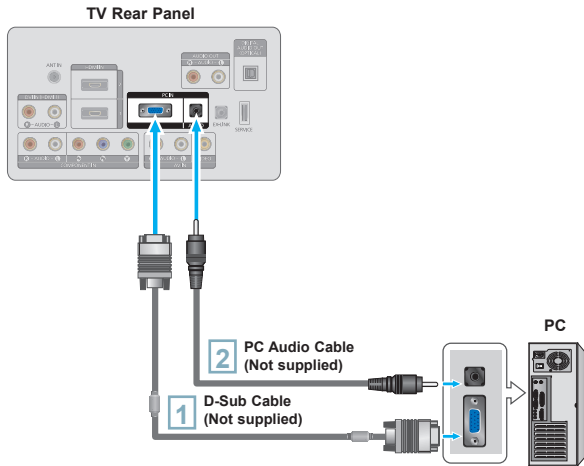

## Using an HDMI/DVI Cable

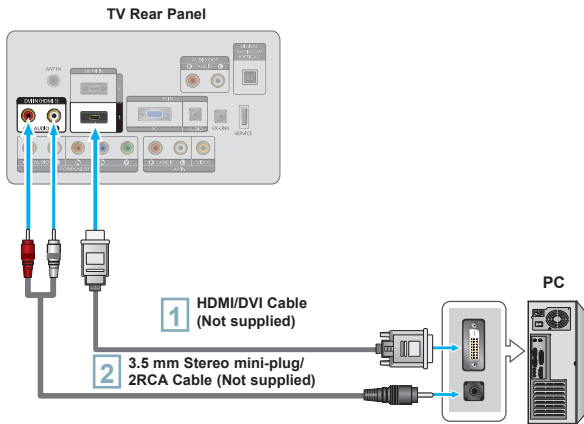

## Using an HDMI Cable

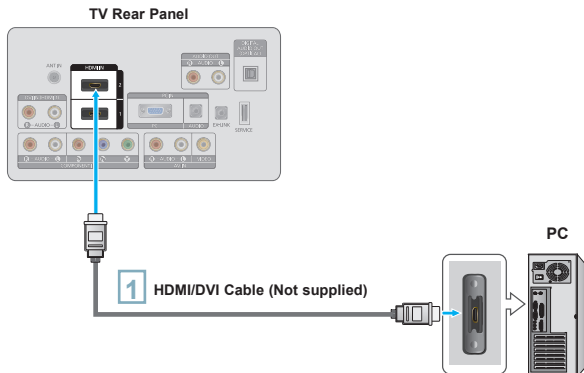

## Using a D-Sub Cable

- 1 Connect a D-Sub Cable between PC IN [PC] connector on the TV and the PC output connector on your computer.
  - 2 Connect a PC Audio Cable between the PC IN [AUDIO] jack on the TV and the Audio Out jack of the sound card on your computer.
- When connecting a PC, match the color of the connection terminal to the cable.

## Using an HDMI/DVI Cable

- 1 Connect an HDMI/DVI cable between the HDMI IN 1 jack on the TV and the PC output jack on your computer.
  - 2 Connect a 3.5 mm Stereo mini-plug / 2RCA Cable between the DVI IN (HDMI 1) [R-AUDIO-L] jack on the TV and the Audio Out jack of the sound card on your computer.
- When using an HDMI/DVI cable connection, you must use the HDMI IN 1 terminal.

## Using an HDMI Cable

- 1 Connect an HDMI cable between the HDMI IN (1 or 2) jack on the TV and the PC output jack on your computer.
- Each PC has a different back panel configuration.

## Turning the TV On and Off

Press the **POWER** button on the remote control. You can also use the **POWER** button on the TV.

## Viewing the Menu

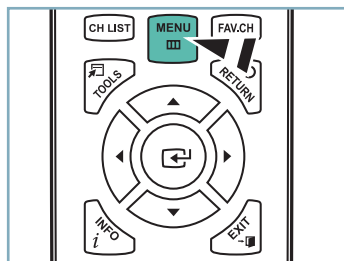

- 1 With the power on, press the **MENU** button. The main menu appears on the screen. The menu's left side has icons: Picture, Sound, Channel, Setup, Input, Support.
- 2 Press the **▲** or **▼** button to select one of the icons. Then press the **ENTER** button to access the icon's sub-menu. Press the **EXIT** button to exit.
  - > The on-screen menus disappear from the screen after about one minute.

## Storing Channels in Memory (Automatic Method)

- 1 Press the **MENU** button to display the menu. Press the **▲** or **▼** button to select "Channel", then press the **ENTER** button.
- 2 Press the **▲** or **▼** button to select "Auto Program", then press the **ENTER** button.
- 3 Press the **▲** or **▼** button to select the antenna connection, then press the **ENTER** button.

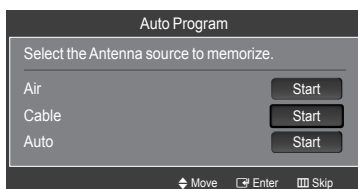

- 4 When selecting the Cable TV system: Press the **ENTER** button to start the auto program.

Press the **▲**, **▼**, **◀** or **▶** to select the correct analog signal cable system source among "STD", "HRC", and "IRC". Press the **▲** or **▼** button to select "Start", then press the **ENTER** button. If you have Digital cable TV, select the cable system signal source for both Analog and Digital.

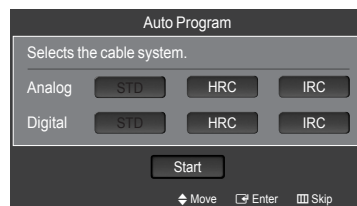

- 5 The TV begins memorizing all available stations. Press the **EXIT** button to exit.

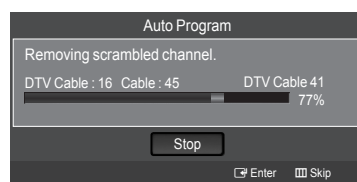
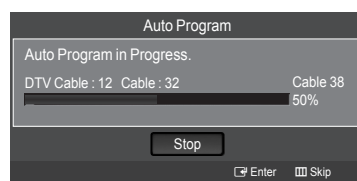

- > After all the available channels are stored, it starts to remove scrambled channels. The Auto program menu then reappears.

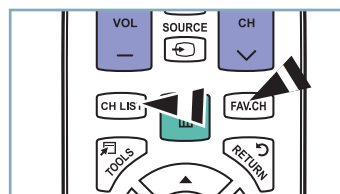

## To Stop the Auto Program Function

Press the **MENU** button while the Auto Program function is being executed. You can also press the **ENTER** button to stop the setup.

## Checking to see if Channels were Stored in Memory

Press the **CH** button. Only the channels stored in memory will be selected (in order).

## Selecting the antennas

- **Air:** "Air" antenna signal.
- **Cable:** "Cable" antenna signal.
- **Auto:** "Air" and "Cable" antenna signals.

## Setting the Channel List

You can delete or add a channel to display the channels you want.

- 1 Press the **MENU** button. Press the **▲** or **▼** button to select "Channel", then press the **ENTER** button. Press the **▲** or **▼** button to select "Channel List", then press the **ENTER** button.
- 2 Press the **◀** button to select "Added Channels". Press the **▲** or **▼** button to select "All Channels". Press the **ENTER** button.
- 3 Press the **▲** or **▼** button to select a channel to delete, then press the **TOOLS** button. Press the **ENTER** button to select "Delete".
- 4 Press the **▲** or **▼** button to select a channel to add, then press the **TOOLS** button. Press the **ENTER** button and the channel is added.

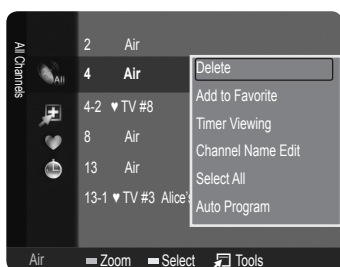

## Setting Your Favorite Channels

You can set channels you watch frequently as favorites.

- 1 Press the **MENU** button. Press the **▲** or **▼** button to select "Channel", then press the **ENTER** button. Press the **▲** or **▼** button to select "Channel List", then press the **ENTER** button.
- 2 Press the **◀** button to select "Added Channels". Press the **▲** or **▼** button to select "All Channels". Press the **ENTER** button.
- 3 Press the **▲** or **▼** button to select a channel as a favorite channel. Press the **TOOLS** button.
- 4 Press the **▲** or **▼** button to select "Add to Favorite", then press the **ENTER** button. The "♥" symbol will be displayed and the channel will be set as a favorite.
  - > The "♥" symbol will be displayed and the channel will be set as a favorite.
  - > All favorite channels will be shown in the "Favorite" menu.

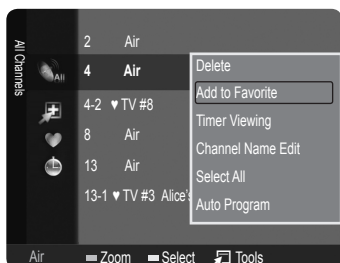

## Changing the Picture Standard

You can select the type of picture which best corresponds to your viewing requirements.

- 1 Press the **MENU** button to display the menu. Press the **ENTER** button, to select "Picture".
- 2 Press the **ENTER** button to select "Mode". Press the **▲** or **▼** button to select "Dynamic", "Standard" or "Movie". Press the **ENTER** button.

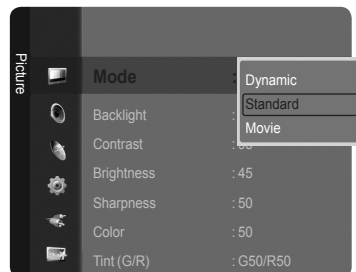

### Picture Mode

- **Dynamic:** Selects the picture for high-definition in a bright room.
- **Standard:** Selects the picture for the optimum display in a normal environment.
- **Movie:** Selects the picture for viewing movies in a dark room.

## Customizing the Picture Settings

Your television has several setting options that allow you to control the picture quality.

- 1 To select the desired picture mode, follow the "Changing the Picture Standard" instructions numbers 1 and 2.
- 2 Press the ▲ or ▼ button to select "Backlight", "Contrast", "Brightness", "Sharpness", "Color" or "Tint(G/R)", then press the **ENTER** button.
- 3 Press the ◀ or ▶ button to decrease or increase the value of a particular item. Press the **EXIT** button to exit.
  - When you make changes to "Backlight", "Contrast", "Brightness", "Sharpness", "Color" or "Tint (G/R)", the OSD will be adjusted accordingly.
  - In PC mode, you can only make changes to "Backlight", "Contrast" and "Brightness".
  - Settings can be adjusted and stored for each external device you have connected to an input of the TV.
  - The energy consumed during use can be significantly reduced if the brightness level of the picture is lowered, which will reduce the overall running cost.

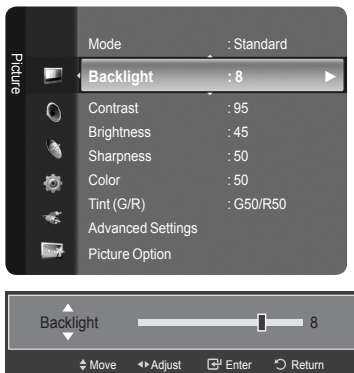

## Picture Adjustment

- **Backlight:** Adjusts the brightness of LCD back light.
- **Contrast:** Adjusts the contrast level of the picture.
- **Brightness:** Adjusts the brightness level of the picture.
- **Sharpness:** Adjusts the edge definition of the picture.
- **Color:** Adjusts color saturation of the picture.
- **Tint(G/R):** Adjusts the color tint of the picture.

## Setting the Screen Size

Occasionally, you may want to change the size of the image on your screen. Your TV comes with six screen size options, each designed to work best with specific types of video input. Your cable box or satellite receiver may have its own set of screen sizes as well. In general, though, you should view the TV in 16:9 mode as much as possible.

- 1 To select the desired picture mode, follow the "Changing the Picture Standard" instructions number 1.
- 2 Press the ▲ or ▼ button to select "Picture Options", then press the **ENTER** button. Press the ▲ or ▼ button to select "Size", then press the **ENTER** button.
- 3 Press the ▲ or ▼ button to select the screen format you want. Press the **ENTER** button. Press the **EXIT** button to exit.
  - **16:9:** Sets the picture to 16:9 wide mode.
  - **Zoom1:** Magnifies the size of the picture on the screen.
  - **Zoom2:** Magnifies the size of the picture more than "Zoom1".
  - **Wide Fit:** Enlarges the aspect ratio of the picture to fit the entire screen.
  - **4:3:** Sets the picture to 4:3 normal mode.
  - **Screen Fit:** Use the function to see the full image without any cutoff when HDMI (720p/1080i), Component (1080i) or DTV (1080i) signals are input.



## To Select the Source

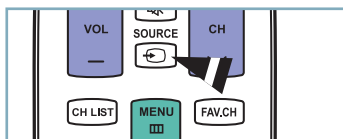

## Press the SOURCE button on the Remote Control

You can select the TV mode or an input source connected to the TV set. Use this button to choose an input source that you would like to watch.

- > Available signal sources: TV / AV / Component / PC / HDMI1/DVI. (LN19B360, LN19B361, LN22B360)  
TV / AV / Component / PC / HDMI1/DVI / HDMI2. (LN26B360, LN32B360)
- > You can choose only those external devices that are connected to the TV. In the "Source List", connected inputs will be highlighted and sorted to the top. Inputs that are not connected will be sorted to the bottom.
- > Using the Color buttons on the remote with the Source list
  - **Red** (Refresh): Refreshes the connected external devices. Press this if your Source is on and connected, but does not appear in the list.
  - **TOOLS** (Tools): Displays the Edit Name and Information menus.

# Troubleshooting

If the TV seems to have a problem, first try this list of possible problems and solutions. If none of these troubleshooting tips apply, please visit [Samsung.com](http://Samsung.com) or contact the Samsung call center at 1-800-SAMSUNG (726-7864).

Problem	Possible Solution
Poor picture	Try another channel. / Adjust the antenna. / Check all wire connections.
Poor sound quality.	Try another channel. / Adjust the antenna.
No picture or sound.	Try another channel. / Press the <b>SOURCE</b> button. / Make sure the TV is plugged in. / Check the antenna connections.
No sound or sound is too low at maximum volume.	First, check the volume of units connected to your TV (digital broadcasting receiver, DVD, cable broadcasting receiver, VCR, etc.). Then, adjust the TV volume accordingly.
Picture rolls vertically.	Check all wire connections.
There is a problem with the picture	Run the Picture test in the Self diagnostic menu.
There is a problem with the sound	Run the Sound test in the Self diagnostic menu.
The TV operates erratically.	Unplug the TV for 30 seconds, then try operating it again.
The TV won't turn on.	Make sure the wall outlet is working.
Remote control malfunctions	Replace the remote control batteries. Clean the upper edge of the remote control (transmission window). Check the battery terminals.
'Check signal cable' message.	Ensure that the signal cable is firmly connected to the PC source.
'Not Supported Mode' message.	Check the maximum resolution and connected device's Video frequency. Compare these values with the data in the Display Modes.
Digital broadcasting screen problem.	Please check the digital signal strength and input antenna.
The image is too light or too dark.	Adjust the Brightness and Contrast. / Adjust the Fine tuning.
Black bars on the screen.	Make sure the broadcast you're receiving is High Definition (HD). HD channels sometimes broadcast Standard Definition (SD) programming, which can cause black bars. Set your cable/satellite box to stretch or widescreen mode to eliminate the bars.
Picture has a Red/Green or Pink tint.	Make sure the Component cables are connected to the correct jacks.
Closed Captioning not working.	If you are using a Cable/Satellite box, you must set Closed Captioning on the box, not your TV.
Snowy picture.	Your cable box may need a firmware upgrade. Please contact your Cable company.
Ghosting on picture	This is sometimes caused by compatibility issues with your cable box. Try connecting Component cables instead.
Horizontal bars appear to flicker, jitter or shimmer on the image.	Adjust the Coarse tuning and then adjust the Fine tuning.
Vertical bars appear to flicker, jitter or shimmer on the image.	Adjust the Coarse tuning and then adjust the Fine tuning.
Screen is black and power indicator light blinks steadily.	On your computer check: Power, Signal Cable. The TV is using its power management system. Move the computer's mouse or press any key on the keyboard.
Image is not centered on the screen.	Adjust the horizontal and vertical position. The screen position must be adjusted on the output source (i.e. STB) with a digital signal.
The picture appears distorted in the corner of the screen.	If "Screen Fit" is selected with some external devices, the picture may appear distorted in the corner of the screen. This symptom is caused by the external devices, not TV.
The 'Resets all settings to the default values' message appears.	This appears when you press and hold the <b>EXIT</b> button for a while. The product settings are reset to the factory defaults.

***This page is intentionally  
left blank.***



**Contact SAMSUNG WORLDWIDE**

If you have any questions or comments relating to Samsung products, please contact the SAMSUNG customer care center.

**Comuníquese con SAMSUNG WORLDWIDE**

Si desea formular alguna pregunta o comentario en relación con los productos de Samsung, comuníquese con el centro de atención al cliente de SAMSUNG.

Country	Customer Care Center ☎	Web Site	Address
CANADA	1-800-SAMSUNG(726-7864)	www.samsung.com/ca	Samsung Electronics Canada Inc., Customer Service 55 Standish Court Mississauga, Ontario L5R 4B2 Canada
			Samsung Electronique Canada Inc., Service à la Clientèle 55 Standish Court Mississauga, Ontario L5R 4B2 Canada
U.S.A	1-800-SAMSUNG(726-7864)	www.samsung.com	Samsung Electronics America, Inc. 105 Challenger Road Ridgefield Park, NJ 07660-0511



BN68-01976D-00