

RESIDENTIAL DIRECT VENT GAS WATER HEATERS

NOT FOR USE IN MANUFACTURED (MOBILE) HOMES



GAMA certification applies to all residential gas water heaters with capacities of 20 to 100 gallons with input rating of 75,000 BTU/Hr. or less.



WARNING: If the information in these instructions is not followed exactly, a fire or explosion may result causing property damage, personal injury or death.

- Do not store or use gasoline or other flammable vapors and liquids in the vicinity of this or any other appliance.
- **WHAT TO DO IF YOU SMELL GAS:**
 - Do not try to light any appliance.
 - Do not touch any electrical switch; do not use any phone in your building.
 - Immediately call your gas supplier from a neighbor's phone. Follow the gas supplier's instructions.
 - If you cannot reach your gas supplier, call the fire department.
- Installation and service must be performed by a qualified installer, service agency or the gas supplier.

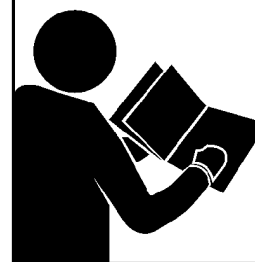

WARNING

Read and understand instruction manual and safety messages before installing, operating or servicing this water heater.

Failure to follow instructions and safety messages could result in death or serious injury.

Instruction manual must remain with water heater.

• For Your Safety •

AN ODORANT IS ADDED TO THE GAS USED BY THIS WATER HEATER.

ALL TECHNICAL AND WARRANTY QUESTIONS: SHOULD BE DIRECTED TO THE LOCAL DEALER FROM WHOM THE WATER HEATER WAS PURCHASED. IF YOU ARE UNSUCCESSFUL, PLEASE WRITE TO THE COMPANY LISTED ON THE RATING PLATE ON THE WATER HEATER.





**KEEP THIS MANUAL IN THE POCKET ON HEATER FOR FUTURE REFERENCE
WHENEVER MAINTENANCE ADJUSTMENT OR SERVICE IS REQUIRED.**

SAFE INSTALLATION, USE AND SERVICE

Your safety and the safety of others is extremely important in the installation, use and servicing of this water heater.

Many safety-related messages and instructions have been provided in this manual and on your own water heater to warn you and others of a potential injury hazard. Read and obey all safety messages and instructions throughout this manual. It is very important that the meaning of each safety message is understood by you and others who install, use or service this water heater.

	This is the safety alert symbol. It is used to alert you to potential personal injury hazards. Obey all safety messages that follow this symbol to avoid possible injury or death.
---	--

	DANGER indicates an imminently hazardous situation which, if not avoided, could result in injury or death.
	WARNING indicates a potentially hazardous situation which, if not avoided, could result in injury or death.
	CAUTION indicates a potentially hazardous situation which, if not avoided, may result in minor or moderate injury.
	CAUTION used without the safety alert symbol indicates a potentially hazardous situation which, if not avoided, could result in property damage.

All safety messages will generally tell you about the type of hazard, what can happen if you do not follow the safety message and how to avoid the risk of injury.

IMPORTANT DEFINITIONS

- **Qualified Installer:** A qualified installer must have ability equivalent to a licensed tradesman in the fields of plumbing, air supply, venting and gas supply, including a thorough understanding of the requirements of the National Fuel Gas Code as it relates to the installation of gas fired water heaters. The qualified installer must also be familiar with the design features and use of flammable vapor ignition resistant water heaters, and have a thorough understanding of this instruction manual.
- **Service Agency:** A service agency also must have ability equivalent to a licensed tradesman in the fields of plumbing, air supply, venting and gas supply, including a thorough understanding of the requirements of the National Fuel Gas Code as it relates to the installation of gas fired water heaters. The service agency must also have a thorough understanding of this instruction manual, and be able to perform repairs strictly in accordance with the service guidelines provided by the manufacturer.
- **Gas Supplier:** The Natural Gas or Propane Utility or service who supplies gas for utilization by the gas burning appliances within this application. The gas supplier typically has responsibility for the inspection and code approval of gas piping up to and including the Natural Gas meter or Propane storage tank of a building. Many gas suppliers also offer service and inspection of appliances within the building.
- **Piezo-Electric Spark Gas Ignition System:** A combination of a piezo-electric spark generator, high voltage lead(s) and a spark electrode(s) designed to ignite pilot burner gas at an appliance burner.

GENERAL SAFETY

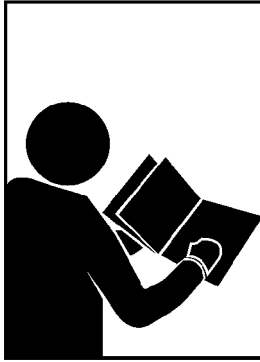

⚠ WARNING

Read and understand instruction manual and safety messages before installing, operating or servicing this water heater.

Failure to follow instructions and safety messages could result in death or serious injury.

Instruction manual must remain with water heater.



⚠ WARNING

Fire Hazard

For continued protection against risk of fire:

- Do not install water heater on carpeted floor.
- Do not operate water heater if flood damaged.

⚠ DANGER

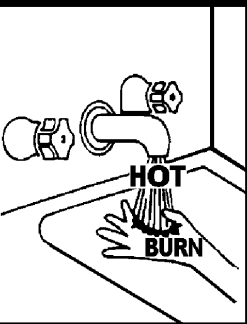

Water temperature over 125°F (52°C) can cause severe burns instantly resulting in severe injury or death.

Children, the elderly, and the physically or mentally disabled are at highest risk for scald injury.

Feel water before bathing or showering.

Temperature limiting valves are available.

Read instruction manual for safe temperature setting.

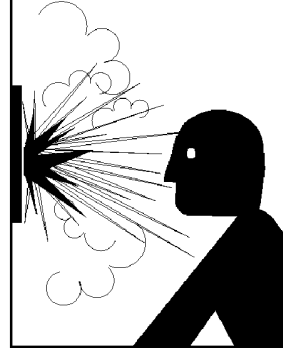

⚠ WARNING

Explosion Hazard

- Overheated water can cause water tank explosion.
- Properly sized temperature and pressure relief valve must be installed in opening provided.

⚠ WARNING

Fire or Explosion Hazard

- Do not store or use gasoline or other flammable vapors and liquids in the vicinity of this or any other appliance.
- Avoid all ignition sources if you smell LP gas.
- Do not expose water heater control to excessive gas pressure.
- Use only gas shown on rating plate.
- Maintain required clearances to combustibles.
- Keep ignition sources away from faucets after extended period of non-use.



Read instruction manual before installing, using or servicing water heater.



⚠ WARNING

Breathing Hazard - Carbon Monoxide Gas



- Install vent system in accordance with codes.
- Do not operate water heater if flood damaged.
- High altitude orifice must be installed if a standard model is installed above 2,000 feet (610 m) or a high altitude model is installed above 4,500 feet (1,370 m).
- Do not operate if soot buildup.
- Do not obstruct water heater air intake with insulating jacket.
- Do not place chemical vapor emitting products near water heater.
- Gas and carbon monoxide detectors are available.
- No vent damper installation is compatible with this direct vent water heater.

Breathing carbon monoxide can cause brain damage or death. Always read and understand instruction manual.

⚠ DANGER

Fire or Explosion Hazard

- Do not store or use gasoline or other flammable vapors and liquids in the vicinity of this or any other appliance.



Flammable Vapors

CAUTION

Improper installation and use may result in property damage.

- Do not operate water heater if flood damaged.
- Inspect and replace anode.
- Install in location with drainage.
- Fill tank with water before operation.
- Be alert for thermal expansion.

Refer to instruction manual for installation and service.

TABLE OF CONTENTS

SAFE INSTALLATION, USE AND SERVICE	2	Start Up Conditions	31
GENERAL SAFETY	3	Condensate	32
TABLE OF CONTENTS	4	Smoke/Odor	32
INTRODUCTION	4	Thermal Expansion	32
Preparing for the New Installation	4	Strange Sounds	32
TYPICAL INSTALLATION	5-6	OPERATIONAL CONDITIONS	32
LOCATING THE NEW WATER HEATER	7	Smelly Water	32
Facts to Consider About Location	7-8	“Air” in Hot Water Faucets	32
Venting Clearances	8	High Temperature Shut Off System	32
Optional Wire Grill	9	PERIODIC MAINTENANCE	33
Flue Extensions	9	Venting System Inspection	33
Vertical Height (Extension Kit)	10	Burner Inspection	33
Horizontal (Extension Kit)	10	Burner Cleaning	33
Vent Installations	11-24	Housekeeping	34
INSTALLING THE NEW WATER HEATER	25	Anode Rod Inspection	34
Water Piping	25	Temperature-Pressure Relief Valve Operation	34
Temperature-Pressure Relief Valve	26	Draining	34
Filling the Water Heater	27	Drain Valve Washer Replacement	35
Gas Piping	27-28	LEAKAGE CHECKPOINTS	35
Sediment Traps	28	REPAIR PARTS	36
Installation Checklist	29	TROUBLESHOOTING	40
LIGHTING & OPERATING LABEL	30	NOTES	41-43
TEMPERATURE REGULATION	31	WARRANTY	Insert
FOR YOUR INFORMATION	31		

INTRODUCTION

Thank You for purchasing this water heater. Properly installed and maintained, it should give you years of trouble free service.

Abbreviations Found In This Instruction Manual:

- CSA - Canadian Standards Association
- ANSI - American National Standards Institute
- NFPA - National Fire Protection Association
- ASME - American Society of Mechanical Engineers
- GAMA - Gas Appliance Manufacturer’s Association

This gas-fired water heater is design certified by CSA INTERNATIONAL under American National Standard/CSA Standard for Gas Water Heaters ANSI Z21.10.1 • CSA 4.1 (current edition).

This gas-fired water heater is equipped with a piezo-electric spark device used for pilot burner ignition, and complies with the Standard for Manually-Operated Piezo-Electric Spark Gas Ignition Systems and Components, ANSI Z21.77 • CGA 6.23.

PREPARING FOR THE INSTALLATION

1. Read the “General Safety” section, page 3 of this manual first and then the entire manual carefully. If you don’t follow the safety rules, the water heater will not operate properly. It could cause DEATH, SERIOUS BODILY INJURY AND/OR PROPERTY DAMAGE.

This manual contains instructions for the installation, operation, and maintenance of the gas-fired water heater. It also contains warnings throughout the manual that you must read and be aware of. All warnings and all instructions are essential to the proper operation of the water heater and your safety. Since we cannot put everything on the first few pages, **READ THE ENTIRE MANUAL BEFORE ATTEMPTING TO INSTALL OR OPERATE THE WATER HEATER.**

2. The installation must conform with these instructions and the local code authority having jurisdiction. In the absence of local codes, installations shall comply with the National Fuel Gas Code ANSI Z223.1/NFPA 54. This publication is available from the Canadian Standards Association, 8501 East Pleasant Valley Rd., Cleveland Ohio 44131, or The National Fire Protection Association, 1 Batterymarch Park, Quincy, MA 02269.

3. If after reading this manual you have any questions or do not understand any portion of the instructions, call the local gas utility or the manufacturer whose name appears on the rating plate.

4. Carefully plan the place where you are going to put the water heater. Correct combustion, vent action and vent pipe installation are very important in preventing death from possible carbon monoxide poisoning and fires, see Figures 1 and 2.

Examine the location to ensure the water heater complies with the “Locating the New Water Heater” section in this manual.

5. For California installation this water heater must be braced, anchored or strapped to avoid falling or moving during an earthquake. See instructions for correct installation procedures. Instructions may be obtained from California Office of the State Architect, 400 P Street, Sacramento, CA 95814.

6. Massachusetts Code requires this water heater to be installed in accordance with Massachusetts 248-CMR 2.00: State Plumbing Code and 248-CMR 5.00.

7. Complies with SCAQMD rule #1121 and districts having equivalent NOx requirements.

TYPICAL INSTALLATION

GET TO KNOW YOUR WATER HEATER - GAS MODELS

- A Vent Assembly
- B Flue Outlet
- C Anode
- D Hot Water Outlet
- E Outlet
- F Insulation
- G Gas Supply
- H Manual Gas Shut-off Valve

- I Ground Joint Union
- J Drip Leg (Sediment Trap)
- K Inner Door
- L Outer Doors with Gaskets
- M Union
- N Inlet Water Shut-off Valve
- O Cold Water Inlet

- P Inlet Dip Tube
- Q Temperature-Pressure Relief Valve
- R Rating Plate
- S Flue Baffle
- T Thermostat
- U Drain Valve
- V Pilot and Main Burner
- W Flue
- X Drain Pan
- Y Piezo Ignitor
- Z Thermostat Shield (optional)

* INSTALL IN ACCORDANCE WITH LOCAL CODES.

* DRIP LEG AS REQUIRED BY LOCAL CODES.

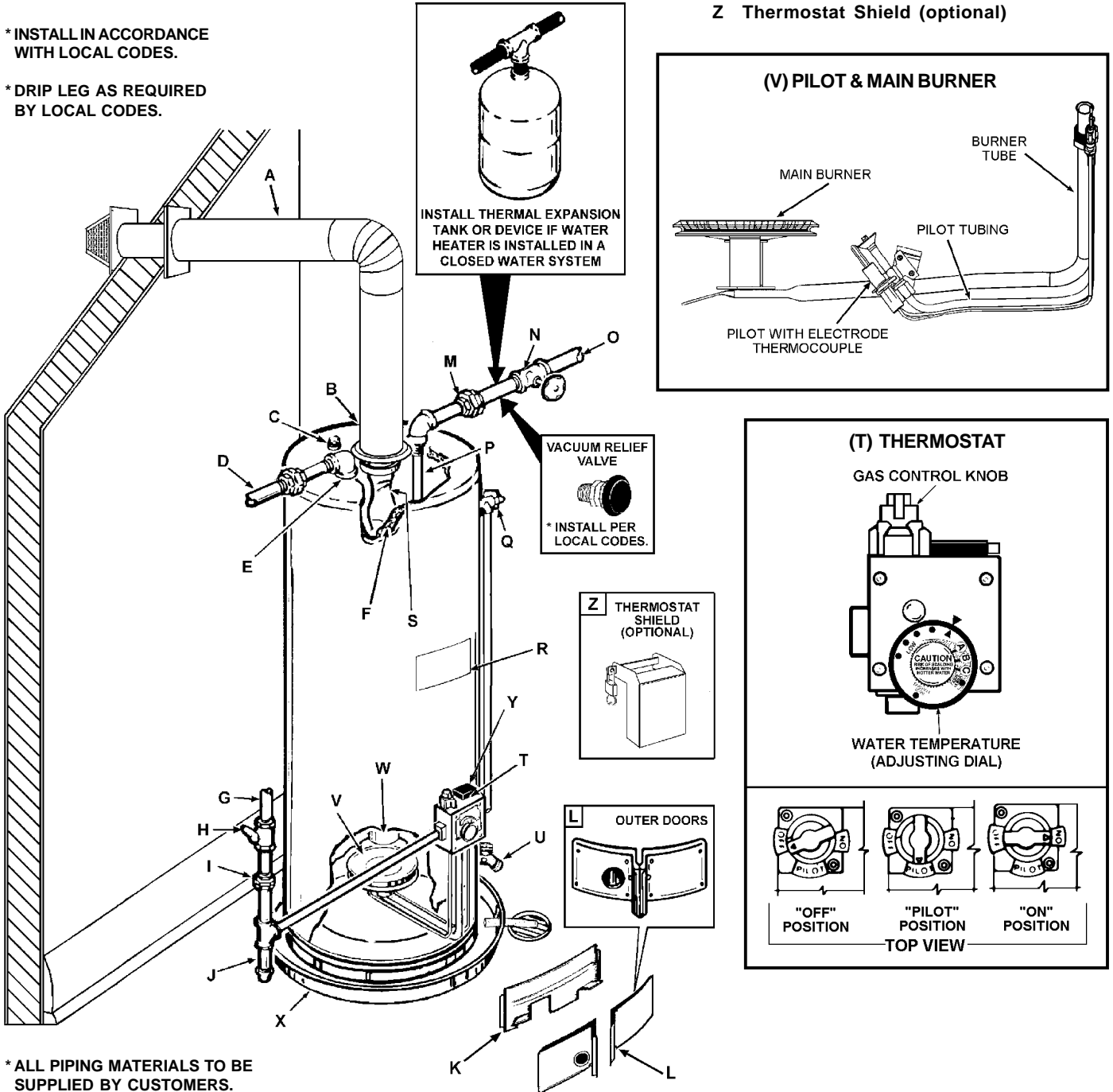

* ALL PIPING MATERIALS TO BE SUPPLIED BY CUSTOMERS.

FIGURE 1.

TYPICAL INSTALLATION

MIXING VALVE USAGE

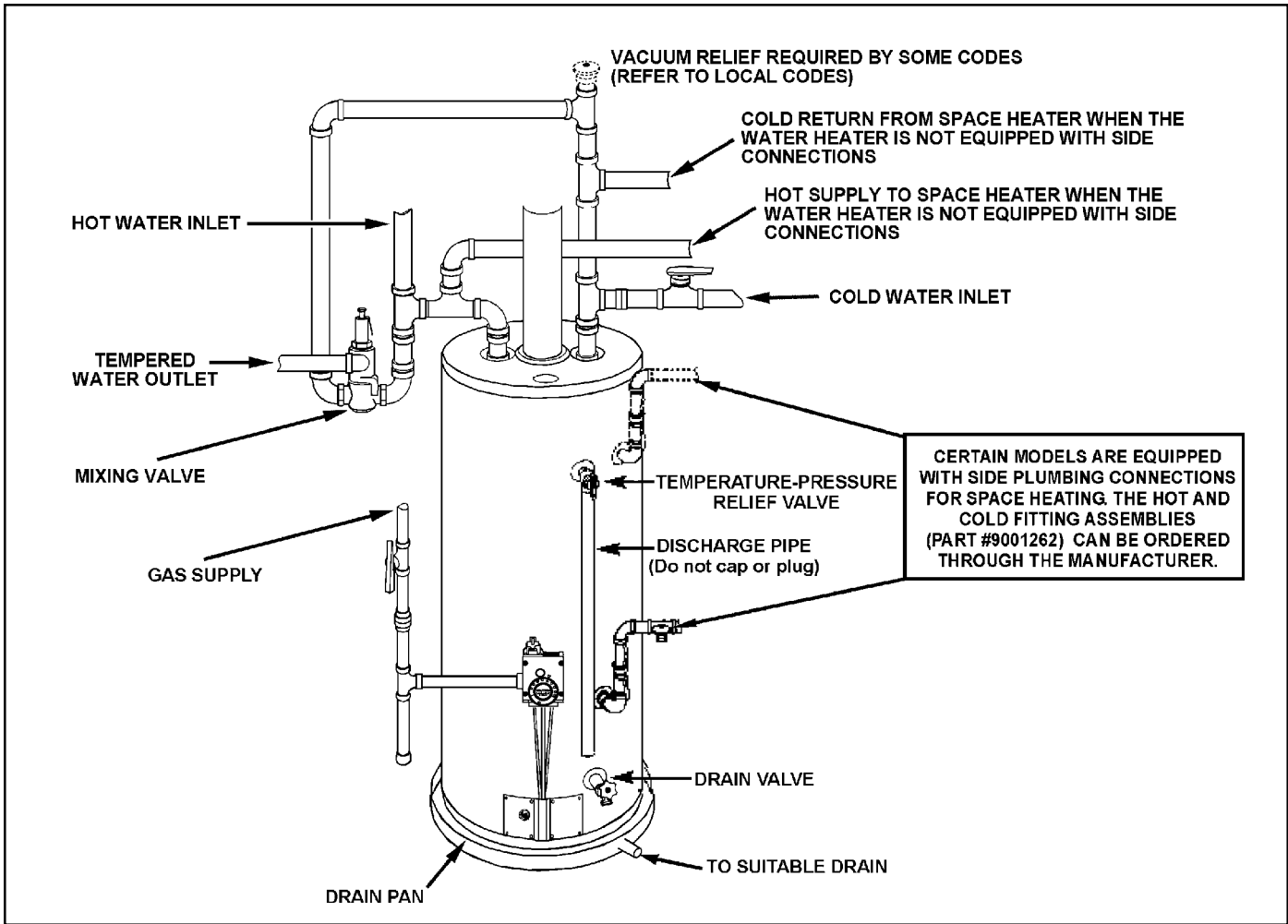

FIGURE 2.

This appliance has been design certified as complying with American National Standard/CSA Standard for water heaters and is considered suitable for:

Water (Potable) Heating: All models are “considered suitable for water (potable) heating.”

Water (Potable) Heating and Space Heating: Certain models are “considered suitable for water (potable) heating and space heating.” Refer to the model and rating plate of the water heater.

HOT WATER CAN SCALD:

Water heaters are intended to produce hot water. Water heated to a temperature which will satisfy space heating, clothes washing, dish washing, and other sanitizing needs can scald and permanently injure you upon contact. Some people are more likely to be permanently injured by hot water than others. These include the elderly, children, the infirm or physically/mentally handicapped. If anyone using hot water in your home fits into one of these groups or if there is a local code or state law requiring a certain temperature water at the hot water tap, then you must take special precautions. In addition to using the lowest possible temperature setting that satisfies your hot water needs, a means such as a *Mixing Valve shall be used at the hot water taps used by these people or at the water heater. Mixing valves are available at plumbing supply or hardware stores. Consult a Qualified Installer or Service Agency. Follow mixing valve manufacturer’s instructions for installation of the valves. Before changing the factory setting on the thermostat, read the “Temperature Regulation” section in this manual, see Figures 109 and 110.

HOT
BURN

⚠ DANGER

Water temperature over 125°F (52°C) can cause severe burns instantly resulting in severe injury or death.

Children, the elderly, and the physically or mentally disabled are at highest risk for scald injury.

Feel water before bathing or showering.

Temperature limiting valves are available.

Read instruction manual for safe temperature setting.

LOCATING THE NEW WATER HEATER

FACTS TO CONSIDER ABOUT THE LOCATION

Carefully choose an indoor location for the new water heater, because the placement is a very important consideration for the safety of the occupants in the building and for the most economical use of the appliance. **This water heater is not for use in manufactured (mobile) homes or outdoor installation.**

Whether replacing an old water heater or putting the water heater in a new location, the following critical points must be observed:

1. The location selected should be indoors, as close as practical to the outside wall through which the water heater vent is going to be installed, and as centralized with the water piping system as possible. The water heater, as all water heaters, will eventually leak. Do not install without adequate drainage provisions where water flow will cause damage.
2. Selected location must provide adequate clearances for servicing and proper operation of the water heater.

CAUTION

Property Damage Hazard

- All water heaters eventually leak.
- Do not install without adequate drainage.

Installation of the water heater must be accomplished in such a manner that if the tank or any connections should leak, the flow will not cause damage to the structure. For this reason, it is not advisable to install the water heater in an attic or upper floor. When such locations cannot be avoided, a suitable drain pan should be installed under the water heater. Drain pans are available at your local hardware store. Such a drain pan must have a minimum length and width of at least 2 inches (5.1 cm) greater than the water heater dimensions and must be piped to an adequate drain. Drain pan depth must allow for access to the outer doors for servicing the pilot and burner.

Water heater life depends upon water quality, water pressure and the environment in which the water heater is installed. Water heaters are sometimes installed in locations where leakage may result in property damage, even with the use of a drain pan piped to a drain. However, unanticipated damage can be reduced or prevented by a leak detector or water shut-off device used in conjunction with a piped drain pan. These devices are available from some plumbing supply wholesalers and retailers, and detect and react to leakage in various ways:

- Sensors mounted in the drain pan that trigger an alarm or turn off the incoming water to the water heater when leakage is detected.
- Sensors mounted in the drain pan that turn off the water supply to the entire home when water is detected in the drain pan.
- Water supply shut-off devices that activate based on the water pressure differential between the cold water and hot water pipes connected to the water heater.
- Devices that will turn off the gas supply to a gas water heater while at the same time shutting off its water supply.

⚠ WARNING

Fire or Explosion Hazard

- Avoid all ignition sources if you smell gas.
- Do not expose water heater control to excessive gas pressure.
- Use only gas shown on rating plate.
- Maintain required clearances to combustibles.
- Keep ignition sources away from faucets after extended period of non-use.



Read instruction manual before installing, using or servicing water heater.



INSTALLATIONS IN AREAS WHERE FLAMMABLE LIQUIDS (VAPORS) ARE LIKELY TO BE PRESENT OR STORED (GARAGES, STORAGE AND UTILITY AREAS, ETC.): Flammable liquids (such as gasoline, solvents, propane [LP or butane, etc.] and other substances such as adhesives, etc.) emit flammable vapors which can be ignited by a gas water heater's pilot light or main burner. The resulting flashback and fire can cause death or serious burns to anyone in the area, as well as property damage. If installation in such areas is your only option, then the installation must be accomplished in a way that the pilot flame and main burner flame are elevated from the floor at least 18 inches (45.7 cm). While this may reduce the chances of flammable vapors, from a floor spill being ignited, gasoline and other flammable substances should never be stored or used in the same room or area containing a gas water heater or other open flame or spark producing appliance. NOTE: Flammable vapors may be drawn by air currents from other areas of the structure to the appliance.

⚠ DANGER

Fire or Explosion Hazard

- Do not store or use gasoline or other flammable vapors and liquids in the vicinity of this or any other appliance.



⚠ WARNING

Fire Hazard

For continued protection against risk of fire:

- Do not install water heater on carpeted floor.
- Do not operate water heater if flood damaged.

Also, the water heater must be located and/or protected so it is not subject to physical damage by a moving vehicle.

This water heater must not be installed directly on carpeting. Carpeting must be protected by metal or wood panel beneath the appliance extending beyond the full width and depth of the appliance by at least 3 inches (7.62 cm) in any direction, or if the appliance is installed in an alcove or closet, the entire floor must be covered by the panel. Failure to heed this warning may result in a fire hazard.

Minimum clearances between the water heater and combustible and noncombustible construction are 0 inch at the sides, 0 inches from back, 4" (10.2 cm) from front of jacket to closet door and 3" (7.6 cm) from top of jacket to combustible and noncombustible material. Minimum vent clearance: 0 inches.

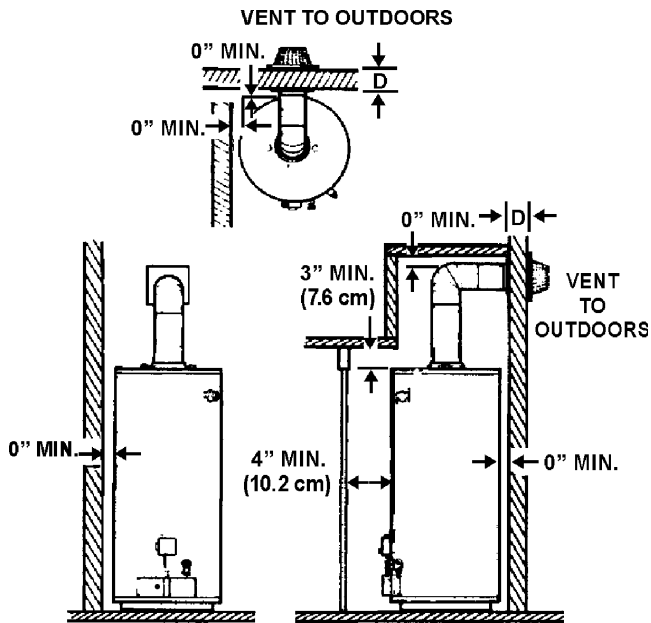

FIGURE 3.

NOTE: Provide 24 inches (61 cm) front clearance for servicing and a adequate clearance between the jacket top and ceiling for servicing the flue area.

Combustion Air and Ventilation

⚠ WARNING

Breathing Hazard - Carbon Monoxide Gas

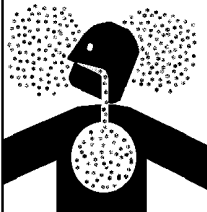

- Do not obstruct water heater air intake with insulating blanket.
- Gas and carbon monoxide detectors are available.
- Install water heater in accordance with the instruction manual.

Breathing carbon monoxide can cause brain damage or death. Always read and understand instruction manual.

No vent damper, whether it is operated thermally or otherwise, is to be installed on this direct vent water heater. Alteration of any part of the factory-furnished vent assembly could result in improper operation due to restriction of flue gases and may cause carbon monoxide poisoning.

Venting Clearances

⚠ WARNING

Failure to have required clearances between vent piping and combustible material will result in a fire hazard.

When determining the installation location for a direct vent water heater, snow accumulation and drifting should be considered in areas where applicable. See Figures 4 through 8 and items below.

- 18" minimum in all directions from any obstruction that may interfere.
- 18" minimum from the ground and 12" from ceiling overhangs.
- The direct vent terminal shall terminate at least 3 feet above any forced air inlet located within 10 feet. See Figure 5.
- 9" minimum horizontally from or above any door, window or gravity air inlet into the building (50,000 BtuH input or less.)
- 12" minimum horizontally from or above any door, window or gravity air inlet into the building (over 50,000 BtuH input).
- 12" minimum below any door, window or gravity air inlet into the building (50,000 BtuH input or less).
- 18" minimum below any door, window or gravity air inlet into the building (over 50,000 BtuH input).
- 18" minimum from other gravity or natural appliance outlet vents when directly above or 135° to either side of center line. See Figure 6.
- 36" minimum from any outlet vents when directly below or 45° to either side of center line. See Figure 7.
- 36" minimum in all directions from any other forced air appliance outlet vent. See Figure 7.
- The location selection must provide clearances for servicing and proper operation of the water heater. See Figure 8.
- Vent termination must not be within 4 feet of any items such as gas meters, gas valves or other gas regulating equipment.
- Unless specified at time of ordering, a standard extension kit (No. 9000687) is individually packaged and shipped with the water heater.**

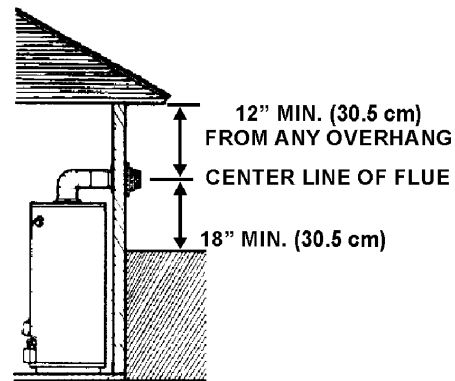

FIGURE 4.

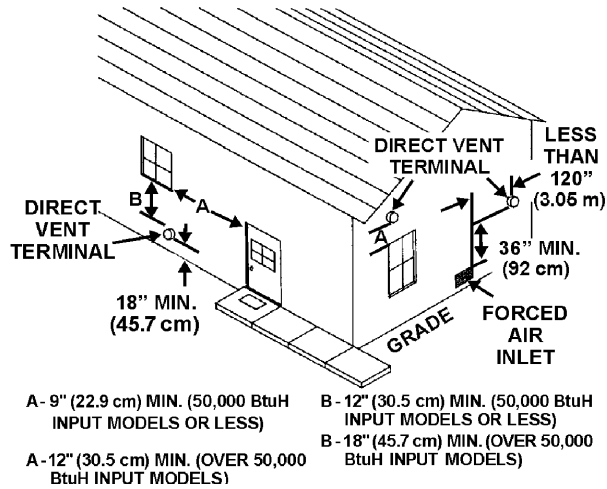

FIGURE 5.

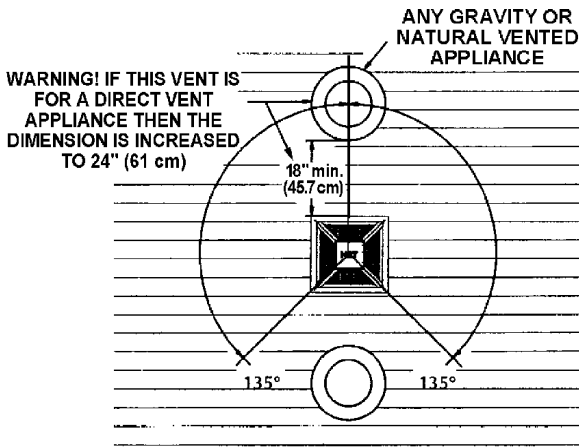

FIGURE 6.

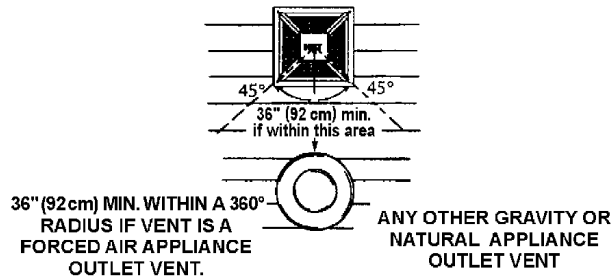

FIGURE 7.

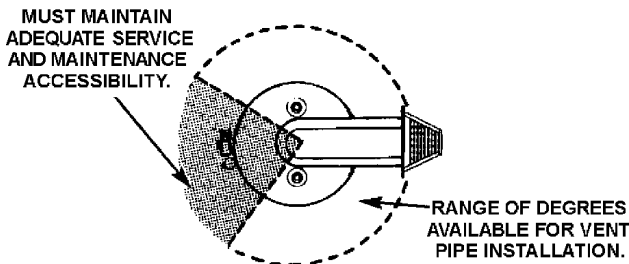

FIGURE 8.

Optional Wire Grill

When the water heater vent cap is low enough to be touched accidentally, or is accessible to small children, installation of a protective vent cover is recommended. See Figure 9.

Some local codes may require a vent cap cover. Figure 9 shows the optional wire vent cap protector available from the water heater manufacturer.

A wire mesh chain link fence (see Figure 9) may be used instead of the factory cover. Care should be taken to maintain adequate ventilation around the vent cap. If a chain link fence is installed, it must not be used as a storage area for items that may block proper ventilation.

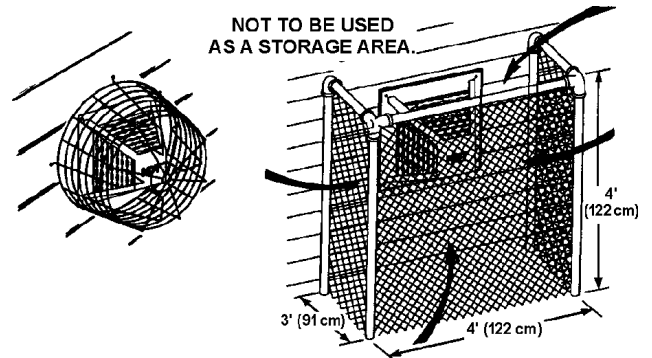

FIGURE 9.

Flue Extensions

There are three optional extension kits available. Any combination of the three kits can be chosen; however, only one kit can be used vertically and/or horizontally, see Figures 10 & 11.

Unless otherwise specified at the time of ordering, a standard extension kit (9000687) is individually packaged and shipped within the water heater carton.

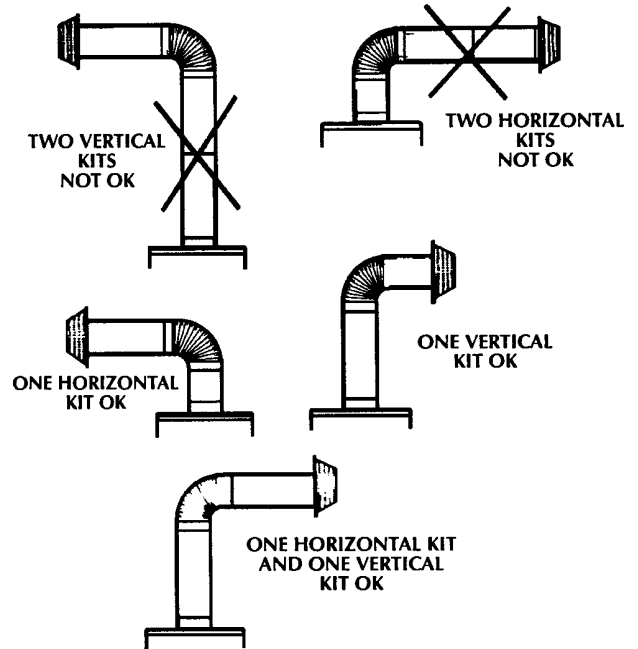

FIGURE 10.

CAUTION

Improper installation and use may result in property damage.

At no time can more than one Vertical Vent Kit and/or one Horizontal Vent Kit be used.

Vertical Height (Extension Kit)

⚠ WARNING

Breathing Hazard - Carbon Monoxide Gas



- Be sure vent pipe is properly connected to prevent escape of dangerous flue gases which could cause deadly asphyxiation.
- Obstructions and deteriorated vent systems may present serious health risk or asphyxiation.

Breathing carbon monoxide can cause brain damage or death. Always read and understand instruction manual.

It is simple to determine which kit is needed for vertical height. Take the total height (to the top of the flue) required and comparing that to "F" dimension" in the chart #1, it can be determined which kit needs to be used vertically.

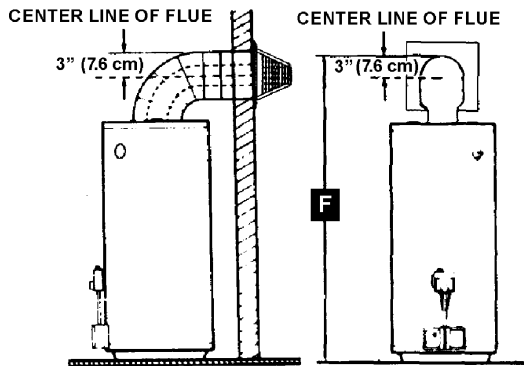
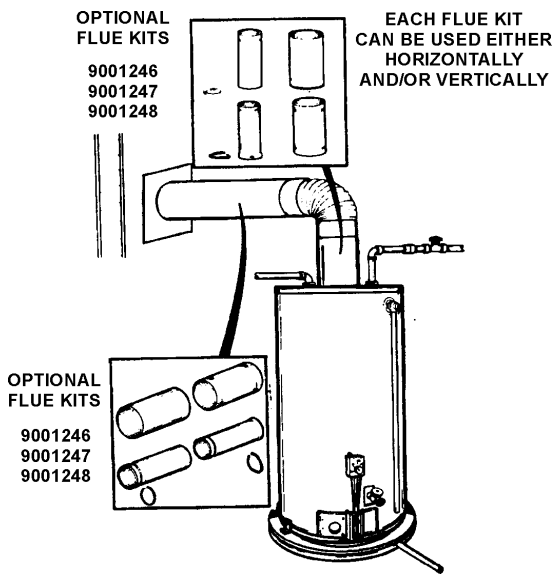

CHART #1.

*Gal. Cap.	BTU's in 1000's Nat./L.P.	DIMENSION "F" (IN INCHES)							
		9000687 STD.	9001246		9001247		9001248		
		MIN.	MAX.	MIN.	MAX.	MIN.	MAX.	MIN.	MAX.
40	36/36	63 3/4	72	77	77	88	88	88	110
50	38/38	72	80 3/4	86	86 1/4	97 1/4	97 1/4	118 3/4	
40	40/40	63 3/4	72	77	77	88	88	88	110
50	48/44	76	84 1/4	89 3/4	89 3/4	100 3/4	100 3/4	122 3/4	
75	55 NAT.	76 1/4	84 1/2	89 1/2	89 1/2	100 1/2	100 1/2	122 1/2	

*Gal. Cap.	BTU's in 1000's Nat./L.P.	DIMENSION "F" (IN CENTIMETERS)							
		9000687 STD.	9001246		9001247		9001248		
		MIN.	MAX.	MIN.	MAX.	MIN.	MAX.	MIN.	MAX.
40	36/36	162	183	196	196	224	224	224	279
50	38/38	183	205	218	219	247	247	247	302
40	40/40	162	183	196	196	224	224	224	279
50	48/44	193	214	228	228	256	256	256	312
75	55 NAT.	194	215	227	227	255	255	255	311

*Check the model and rating plate attached to the water heater for specific model number and other detailed information.

Horizontal (Extension Kit)

To determine the horizontal length and extension kit needed, simply plug the dimensions "D" and "G" into the equation below. The answer "E" should then be located in Chart #2. The size range in which "E" dimension falls indicates the kit that should be used horizontally to obtain the desired length.

"D" = The wall thickness

"G" = The distance wanted between the edge of the water heater and the **inside** edge of the wall

"E" = The distance the extension kit must be able to extend

The Equation: D + G = E

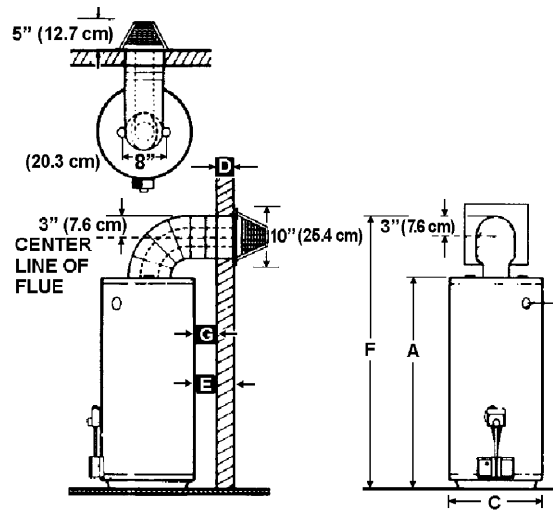

CHART #2.

VENT KITS	DIMENSION "E" (IN INCHES)			
	40-50 GAL.		75 GAL.	
	MIN	MAX	MIN	MAX
9000687-Std.	3 1/2	10	7/8	7 3/8
9001246	10	15 1/2	7 3/8	12 7/8
9001247	15 1/2	26 1/2	12 7/8	23 7/8
9001248	26 1/2	48	23 7/8	45 3/8

VENT KITS	DIMENSION "E" (IN CENTIMETERS)			
	40-50 GAL.		75 GAL.	
	MIN	MAX	MIN	MAX
9000687-Std.	8.9 cm	25.4 cm	2.2 cm	18.7 cm
9001246	25.4 cm	29.4 cm	18.7 cm	32.7 cm
9001247	39.4 cm	67.3 cm	32.7 cm	60.6 cm
9001248	67.3 cm	121.9 cm	60.6 cm	115.3 cm

*Gal. Cap.	BTU's in 1000's Nat.	DIMENSION "A, B, C" (INCHES/CENTIMETERS)					
		A		B		C	
		INCHES	CENTIMETERS	INCHES	CENTIMETERS	INCHES	CENTIMETERS
40	36/36	48 3/4"	124 cm	41 3/4"	106 cm	21"	53 cm
50	38/38	57 1/2"	146 cm	50 1/2"	128 cm	21"	53 cm
40	40/40	48 3/4"	124 cm	41 3/4"	106 cm	21"	53 cm
50	48/44	61"	155 cm	54"	137 cm	21"	53 cm
75	55 NAT.	63"	160 cm	54 3/4"	139 cm	26 1/4"	67 cm

ALL INSTALLATIONS

For ease of assembly the installation of the various kit combinations has been broken into individual sections. The two steps below are common to all installations. Once these have been performed, you need only to refer to the type installation that pertains to you.

Installation Using Vent Kits:

1. Standard Vent Kit 9000687 Page 11
2. Optional Vertical Vent Kit Page 14
with Standard Vent Kit
3. Optional Horizontal Vent Kit Page 17
4. Optional Horizontal Page 19
and Vertical Vent Kits

Cutting The Opening Through The Outside Wall

After thoroughly reading the "Locating the New Water Heater" section of this manual and you have chosen a suitable water heater installation site, use Chart #1 to determine dimensions for the wall opening.

Cut a 6 1/4" (159 mm) diameter hole completely through the outside wall.

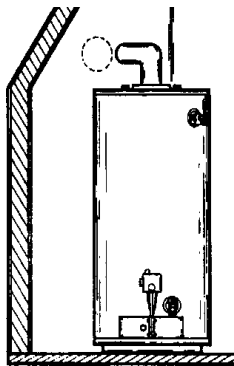

FIGURE 14.

Water Heater Attitude

There is a certain amount of variance with regard to the direction the water heater faces.

Standing in front of the water heater (gas control facing you), set the 3" (76 mm) diameter elbow (slotted end) on the flue. This will give you a better understanding of the relation of the vent assembly to the opening in the wall and more importantly any possibility of interference of venting and water piping.

The direction of the water heater can now be made. Also consider the gas control valve to insure installation, lighting and maintenance accessibility are retained.

NOTE: Supplementary installation instructions are applicable only if this direct vent water heater is provided with the alternate brown porcelain-enameled vent cap and the 6" (152 mm) vent wall assembly show below, See pages 22 thru 24.

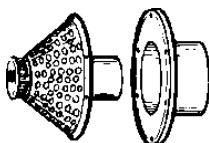

Standard Vent Kit - Installation #1

The opening through the wall should be cut at this time. If this has not been done, refer to "Cutting The Opening Through The Outside Wall" section.

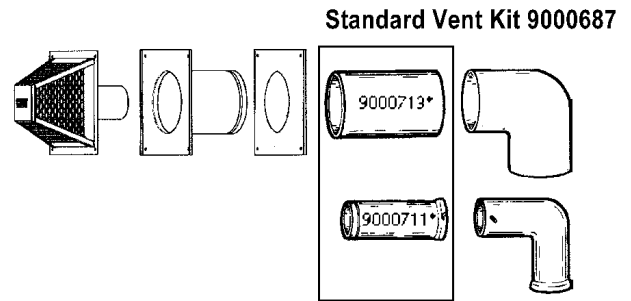

* Each part is stamped with a part number

1. Lock the elbow to the straight 3" (76 mm) flue pipe. Set this assembly in place on the end of the water heater's flue collar.

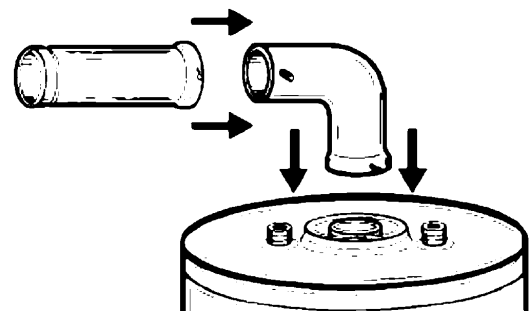

FIGURE 15.

2. Mark the flue collar at the slots in the elbow. Using a #22 drill bit, drill holes into the flue collar at the two slots and secure the elbow to the flue collar using the screws provided.

NOTE: Make sure elbow is properly aligned to opening in the outside wall.

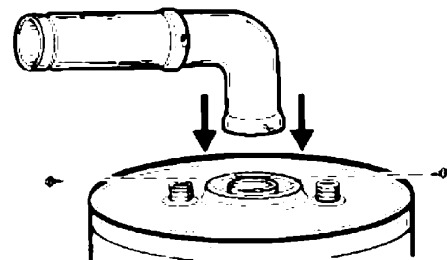

FIGURE 16.

3. Using the tube of sealant supplied, run an ample amount around the oval flare of the jacket.

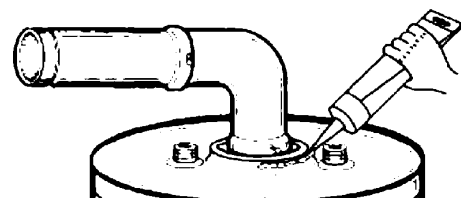

FIGURE 17.

4. First remove the 3" (76 mm) horizontal extension from the elbow. Starting with the long end (with four securing holes), place the 6" (152 mm) diameter vent elbow over the 3" (76 mm) diameter elbow. Bend the round end "oval" to fit the flared oval end of the jacket top.

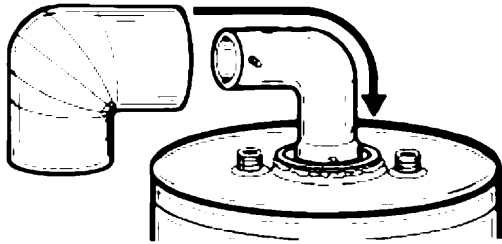

FIGURE 18.

5. Making sure the 6" (152 mm) diameter elbow is centered around the 3" (76 mm) diameter flue, secure the 6" (152 mm) diameter vent pipe using four sheet metal screws at the connection of the jacket top.

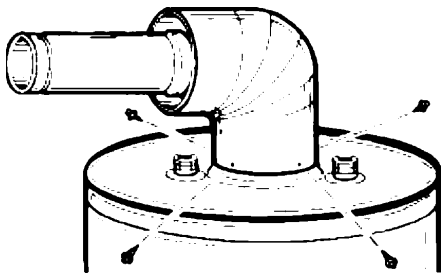

FIGURE 19.

6. The standard vent kit includes a 6" (152 mm) diameter extension pipe which is used when "E" dimension is over 6 1/2" (165 mm).

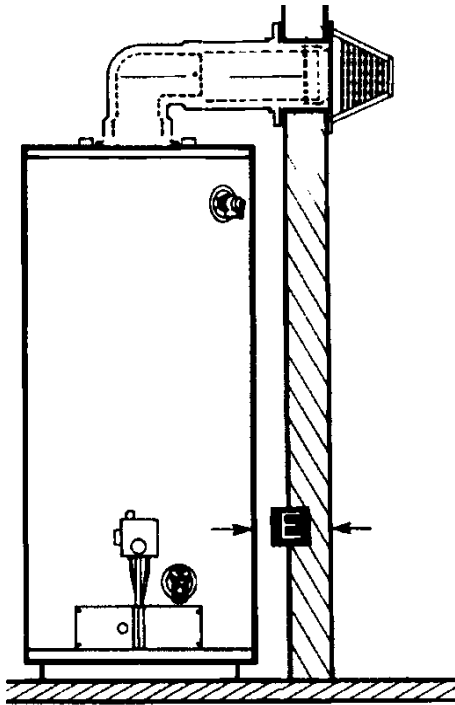

FIGURE 20.

7. If "E" dimension is less than 6 1/2" (165 mm) move to next step.

If "E" dimension is over 6 1/2" (165 mm), assemble the 6" (152 mm) diameter extension pipe (crimped end) to the 6" (152 mm) diameter vent elbow and secure using two sheet metal screws. Apply an ample amount of sealant around the joint to ensure a good seal.

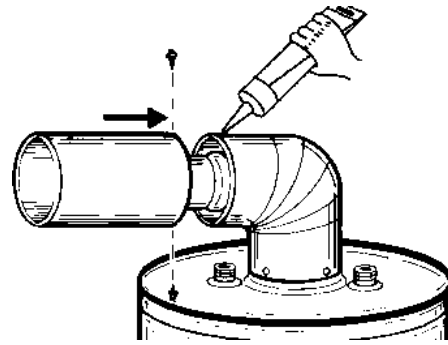

FIGURE 21.

8. Slide the vent collar (to be installed later) over the 6" (152 mm) vent elbow.

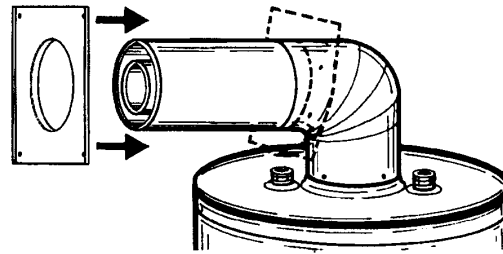

FIGURE 22.

9. Place the water heater at the opening in the wall, at the predetermined clearance.

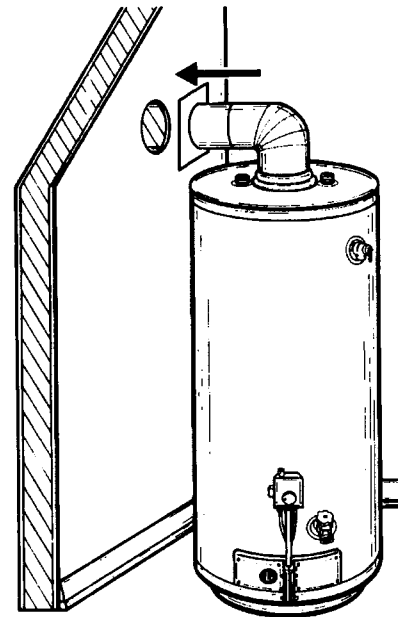

FIGURE 23.

10. Move outdoors with all the remaining vent parts. Using the tube of sealant supplied, run an ample amount on the inside surface of the collar assembly that will contact the exterior wall and also fill the bead on the end of the 6" (152 mm) diameter vent collar.

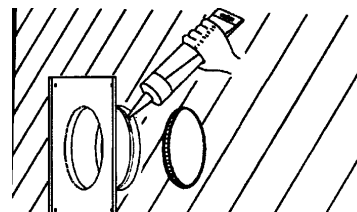

FIGURE 24.

11. Install the vent collar assembly through the wall, connecting it to the extension and/or elbow (depending on which one was used).

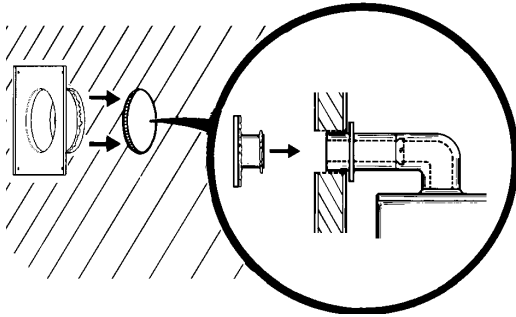

FIGURE 25.

12. We have supplied four wood screws to temporarily attach the collar to the exterior wall of the building. However, other types of screws may have to be substituted depending on the material used in the construction of the exterior wall.

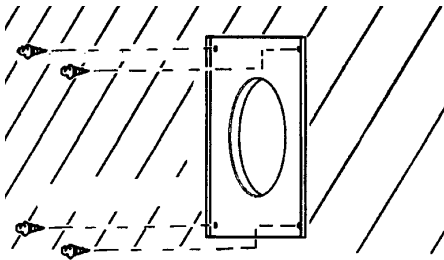
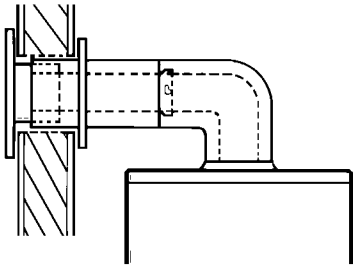

FIGURE 26.

13. Insert the 3" (76 mm) diameter flue extension pipe into the vent collar assembly (flared & notched end first) and lock (turn clockwise to lock studs to slots) the flue extension pipe to the flue elbow.



14. Connect the vent cap by sliding its end over the 3" (76 mm) diameter extension pipe and O-ring.

NOTE: To facilitate ease of assembly of the vent cap to the 3" (76 mm) pipe, a soap solution can be applied to the O-ring gasket.

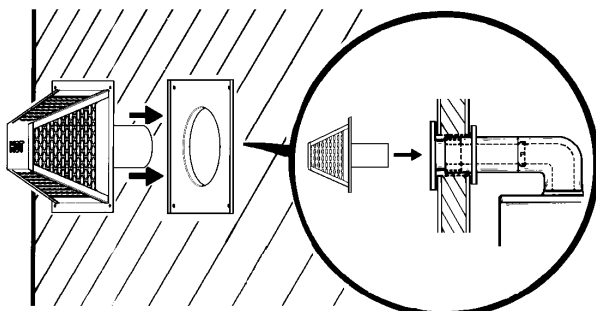

FIGURE 27.

15. The vent cap has four holes around the outer edge. Remove the four screws used to temporarily attach the collar to the exterior wall. Then secure the vent cap assembly with the vent collar assembly to the exterior wall using the same four screws.

NOTE: Screws are supplied: However, substitution may be necessary depending on the exterior wall material.

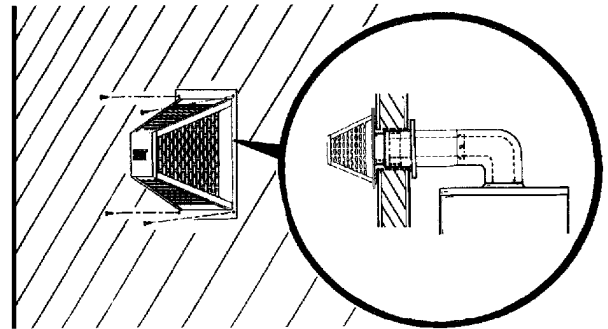
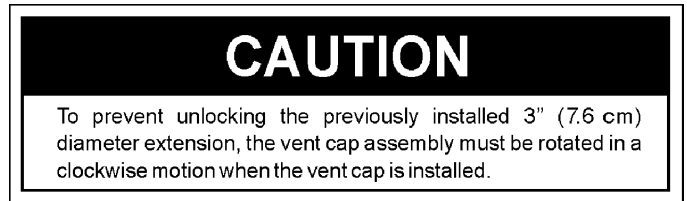

FIGURE 28.

16. Go back indoors to attach inside collar to the inside wall. Place the collar against the wall. Secure to wall by using four long sheet metal screws.

NOTE: Screws are supplied: However, substitution may be necessary depending on the interior wall material.

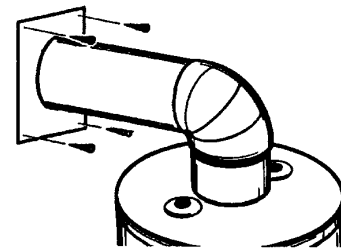

FIGURE 29.

17. Using the tube of sealant supplied, run an ample amount of sealant around the edge of the vent pipe where it is inserted through the inside collar to seal air drafts from wall.

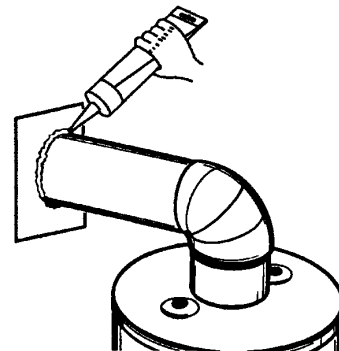
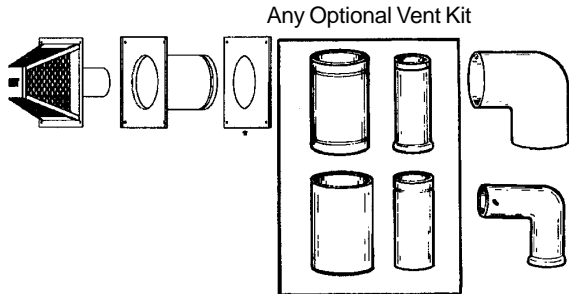

FIGURE 30.

Optional Vertical Vent Kit with Standard Horizontal Vent Kit - Installation #2



*Each part is stamped with a part number.

The opening through the wall should be cut at this time. If this has not been done, refer to "Cutting The Opening Through The Outside Wall," on page 11.

1. First it must be determined how far the vertical 3" (76 mm) diameter telescoping flue sections are set and locked together using the two screws supplied.

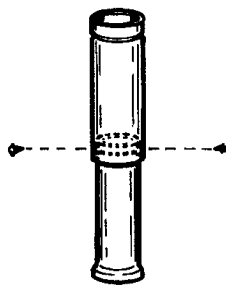

FIGURE 31.

Use chart #3, drawing and simple equation below, to find the length of expansion of the telescoping flue sections. Because of manufacturing tolerances, place the telescoping extension on the water heater and adjust the height ("X" Dimension) and mark the point. Once the length has been determined, lock the two sections together by drilling two holes (180° apart) in the pipe and securing with the screws supplied.

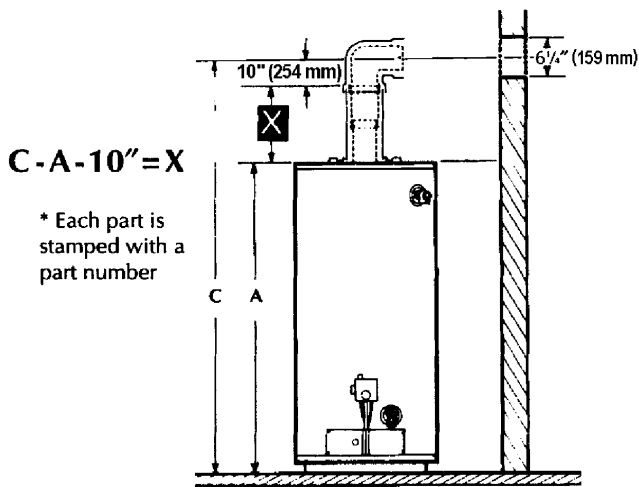

FIGURE 32.

CHART #3

*GAL CAP.	*BTU's in 1000's - NAT./L.P.	A	
40	36/36	48 3/4"	124 cm
50	38/38	57 1/2"	146 cm
40	40/40	48 3/4"	124 cm
50	48/44	61"	155 cm
75	55 NAT.	63"	160 cm

*Check the model and rating plate attached to the water heater for specific model number and other detailed information.

2. Set the vertical 3" (76 mm) diameter telescoping flue section in place on the flue collar. Using a # 22 drill bit, drill two holes (180° apart) and secure the vertical assembly to the flue collar.

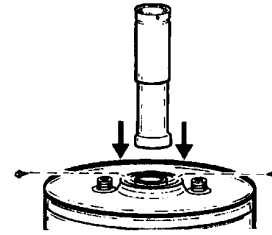

FIGURE 33.

3. Slide the 6" (152 mm) vent telescoping section apart to reveal the beads. Using the caulking supplied, fill the beads.

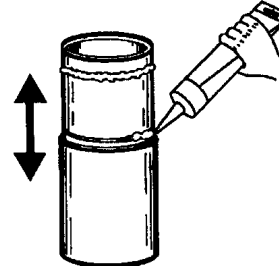

FIGURE 34.

4. Apply an ample amount of sealant around the oval flare of the jacket.

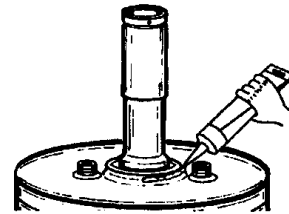

FIGURE 35.

5. Place the 6" (152 mm) vent section over the 3" (76 mm) flue section. Subtract 3/4" (19 mm) from the predetermined "X" dimension. This determines the length of the 6" (152 mm) vent extension. Slide the 6" (152 mm) vent extension apart to this dimension and secure with the two screws supplied.

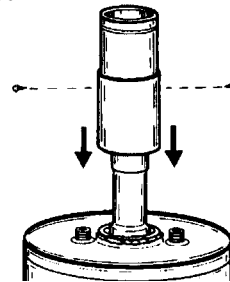

FIGURE 36.

6. Form the round end of the 6" (152 mm) vent extension to the top of the jacket and secure with four sheet metal screws.

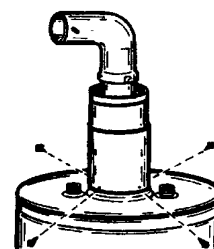

FIGURE 37.

7. Place the 3" (76 mm) elbow on the flue extension.

NOTE: Make sure elbow is properly aligned to opening in the outside wall.

Mark the 3" (76 mm) diameter end of the flue extension at the slots in the elbow. Using a #22 drill bit, drill holes into the flue extension at the two slots and secure the elbow to the flue extension using the screws provided.

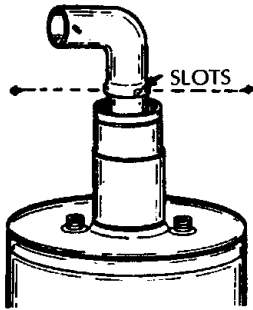

FIGURE 38.

8. Be sure the 6" (152 mm) diameter elbow is centered around the 3" (76 mm) diameter flue. Secure the 6" (152 mm) diameter vent pipe using two sheet metal screws at the connection of the elbow and 6" (152 mm) vertical extension.

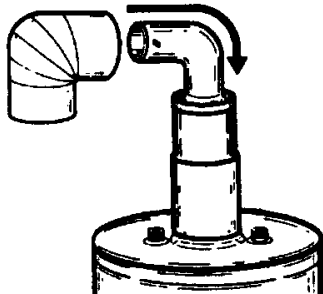

FIGURE 39.

9. The standard vent kit includes a 6" (152 mm) diameter extension pipe which is used when dimension "E" (refer to Chart 2) is over 6 1/2" (165 mm).

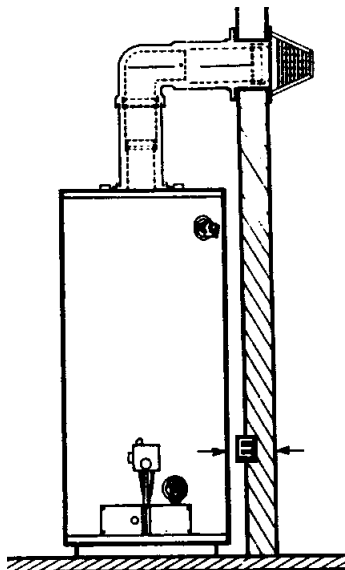

FIGURE 40.

10. If "E" dimension is less than 6 1/2" (165 mm) move to next step. If "E" dimension is over 6 1/2" (165 mm), assemble the 6" (152 mm) diameter extension pipe to the 6" (152 mm) diameter vent elbow and secure using two sheet metal screws. Using the tube of sealant supplied, run an ample amount around the joint to insure a good seal.

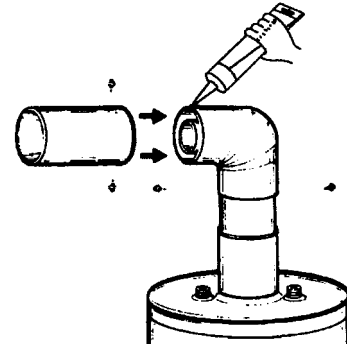

FIGURE 41.

11. Slide the vent collar (to be installed later) over the 6" (152 mm) vent elbow.

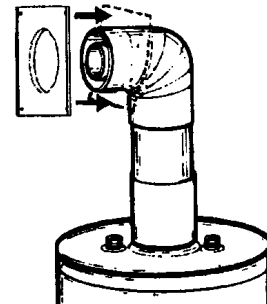

FIGURE 42.

12. Move the water heater into position at the vent opening.

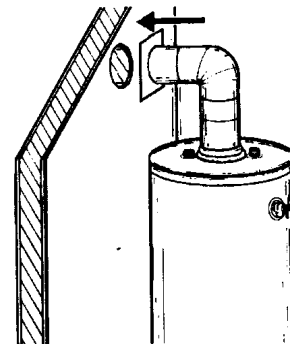

FIGURE 43.

13. Take the remaining vent parts outside to complete the installation. Using the tube of sealant supplied, apply an ample amount of sealant to the inside surface of the collar assembly that will contact the exterior wall. Also, apply sealant to the bead around the outside edge at the end of the 6" (152 mm) diameter vent collar.

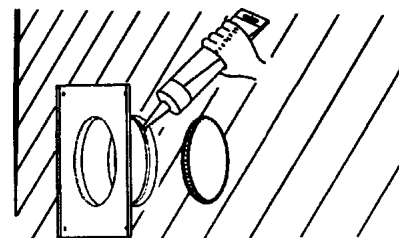

FIGURE 44.

14. Install the vent collar assembly through the wall, connecting it to the extension and/or elbow depending on which one was used.

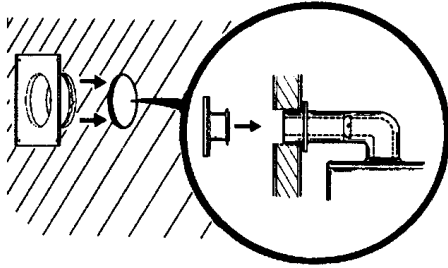

FIGURE 45.

15. Four wood screws are supplied to temporarily attach the collar to the exterior wall of the building. However, other types of screws may have to be substituted depending on the construction material of the exterior wall.

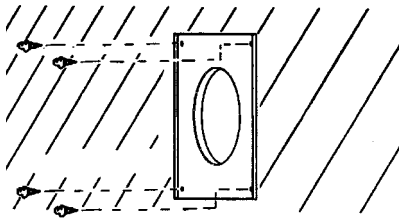

FIGURE 46.

16. Insert the 3" (76 mm) diameter flue extension pipe into the vent collar assembly (flared and notched end first) and rotate clockwise to lock the studs to the slots in the extension pipe.

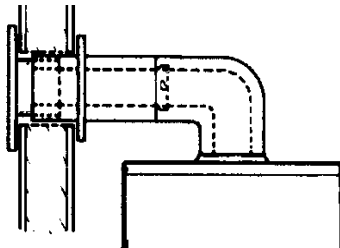

FIGURE 47.

17. Connect the vent cap by sliding its end over the 3" (7.6 cm) diameter extension pipe an O-ring.

NOTE: to facilitate ease of assembly of the vent cap to the 3" (7.6 cm) pipe a soap solution can be applied to the O-ring gasket.

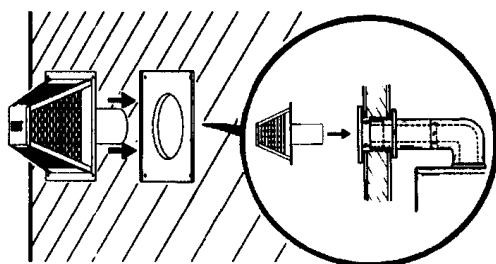

FIGURE 48.

18. The vent cap has four holes around the outer edge. Remove the four screws used to temporarily attach the collar to the exterior wall. Then secure the vent cap to the exterior wall using the same four screws. **NOTE:** Screws are supplied. However, substitution may be necessary depending on the exterior wall material.

CAUTION

To prevent unlocking the previously installed 3" (7.6 cm) diameter extension, the vent cap assembly must be rotated in a clockwise motion when the vent cap is installed.

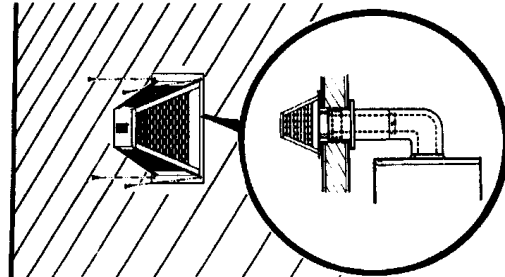

FIGURE 49.

19. Go back indoors to attach inside collar to the inside wall. Place the collar against the wall. Secure to wall by using four long sheet metal screws. **NOTE:** Screws are supplied. However, substitution may be necessary depending on the exterior wall material.

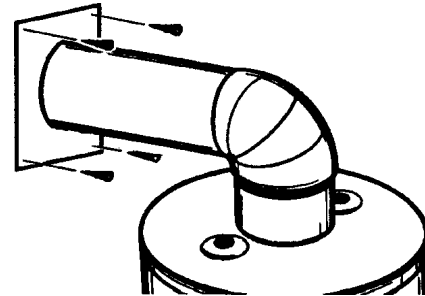

FIGURE 50.

20. Using the tube of sealant supplied, apply an ample amount of sealant around the edge of the vent pipe where it is inserted through the inside collar. This will seal air draft from the walls.

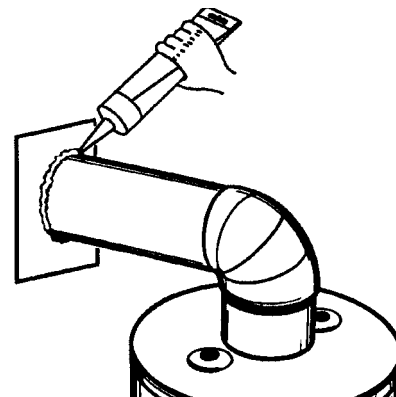
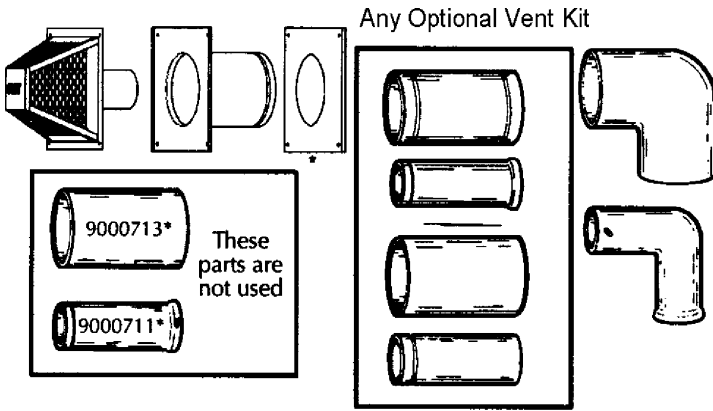

FIGURE 51.

Optional Horizontal Vent Kit - Installation #3



*Each part is stamped with a part number

If the vent hole has not been cut, refer to "Cutting The Opening Through The Outside Wall." See page 11.

1. Lock the elbow to the straight 3" (76 mm) flue pipe. Set this assembly in place on the end of the water heater's flue collar.

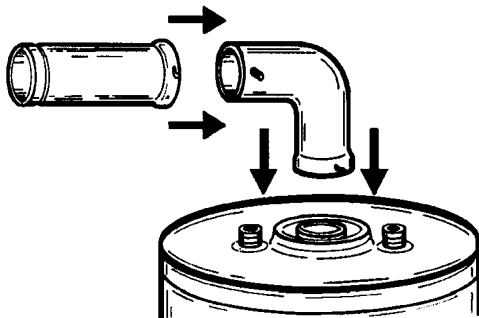

FIGURE 52.

2. Mark the flue collar at the slots in the elbow. Using a # 22 drill bit, drill holes into the collar at the two slots and secure the elbow to the collar with the screws provided.

NOTE: make sure elbow is properly aligned to the opening in the outside wall.

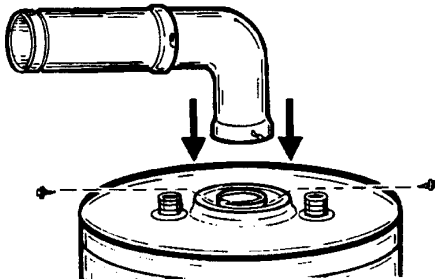

FIGURE 53.

3. Using the tube of sealant supplied run an ample amount around the oval flare of the jacket.

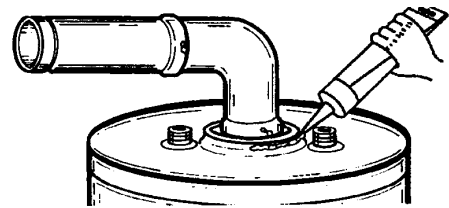

FIGURE 54.

4. First remove the 3" (7.6 cm) horizontal extension from the elbow. Starting with the long end, which has four mounting holes, place the 6" (152 mm) diameter vent elbow over the 3" (76 mm) elbow. Bend the round end to fit the flared oval end of the jacket top.

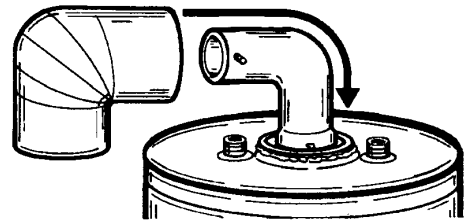

FIGURE 55.

5. Be sure the 6" (152 mm) diameter elbow is centered around the 3" (76 mm) diameter flue. Secure the vent pipe with four sheet metal screws at the connection at the jacket top.

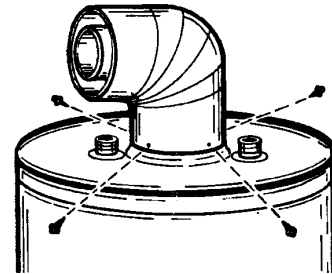
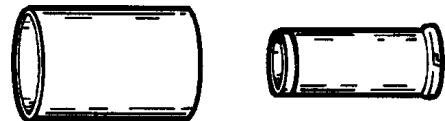

FIGURE 56.

NOTE: the standard kit includes a 3" (76 mm) flue extension and a 6" (152 mm) elbow extension. These parts will not be used with the horizontal kit.



6. Slide the vent collar (to be installed later) over the 6" (152 mm) vent elbow.

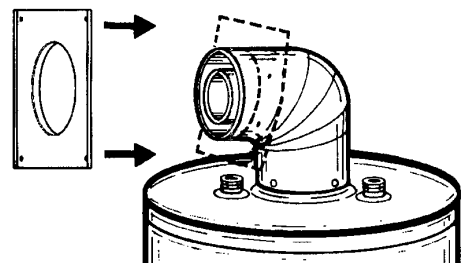

FIGURE 57.

7. Place the waterheater at the opening in the wall at the predetermined clearance.

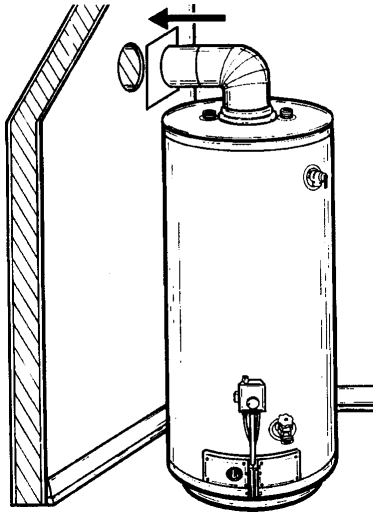

FIGURE 58.

8. Slide the 6" (152 mm) telescoping vent section apart to expose the beads. Use the supplied tube of sealant and fill the exposed beads.

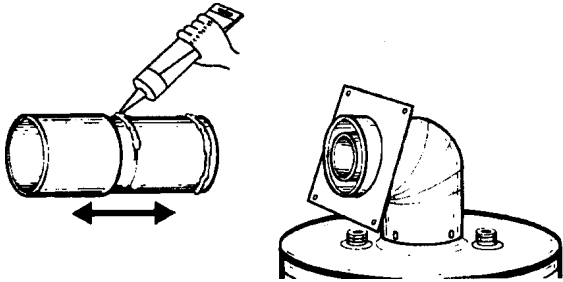

FIGURE 59.

9. Insert the 6" (152 mm) telescoping vent section into the opening in the wall.

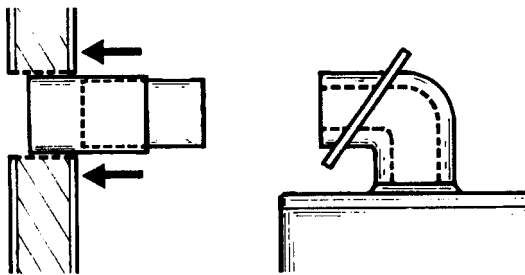

FIGURE 60.

10. The remaining vent parts will be installed from the outside. Apply ample amount of sealant to the inside surface of the collar assembly that will contact the exterior wall. Also, apply sealant to the bead around the outside edge at the end of the 6" (152 mm) diameter vent collar.

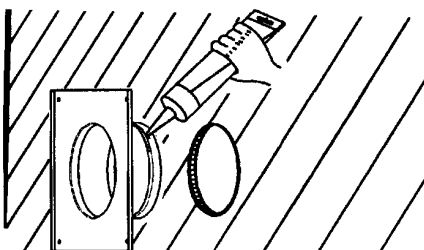

FIGURE 61.

11. Insert the vent collar assembly through the wall opening, connecting to the 6" (152 mm) telescoping extension. Remember, the vent extension has not been connected so it may be necessary to go back outdoors and push it back up into the wall opening for a tight fit to the collar.

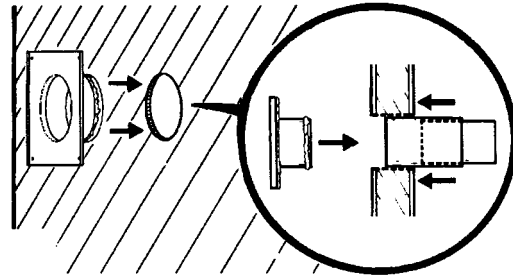

FIGURE 62.

12. Four wood screws were supplied to temporarily attach the collar to the exterior wall of the building. However, you may have to substitute other types of screws depending on the construction material of the exterior wall.

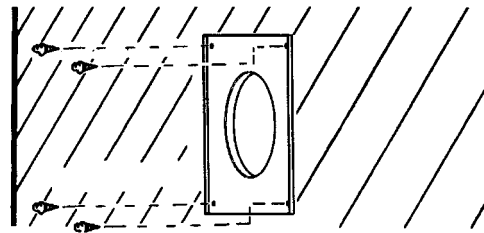

FIGURE 63.

13. Insert the vent cap into the vent collar assembly.

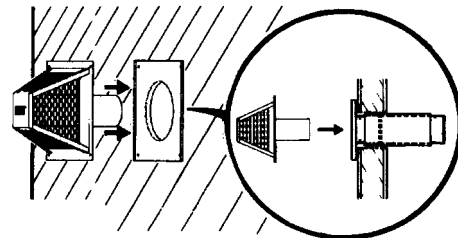

FIGURE 64.

14. The vent cap has four holes around the outer edge. Remove the four screws used to temporarily attach the collar to the exterior wall. Then secure the vent cap assembly with the vent collar assembly to the exterior wall using the same screws.

Note: Screws are supplied; however, substitution may be necessary depending on the exterior wall material.

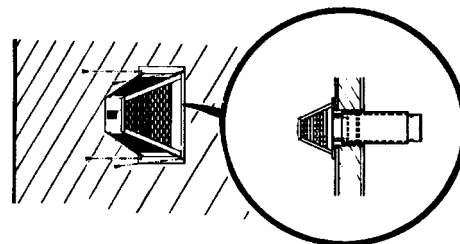

FIGURE 65.

15. The remainder of the installation will be indoors to complete the assembly process.

16. Collapse the 6" flue extension assembly as shown below. Install the O-ring end of the 3" (7.6 cm) extension approximately 1 1/4" (3.2 cm) into the end of the vent cap. If necessary, apply a soap solution to the O-ring to ease the assembly. Rotate the 3" extension clockwise until the other end is locked to the studs on the elbow.

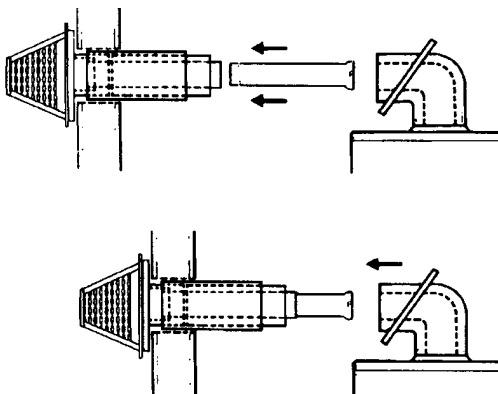

FIGURE 66.

17. Using a # 22 drill bit, drill holes 180° apart at the connection point of the two 3" (7.6 cm) flue extensions. Secure with the two screws provided.

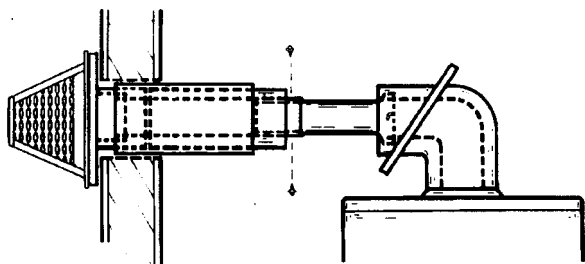

FIGURE 67.

18. Expand the 6" (15.2 cm) telescoping extension to connect at the vent elbow.

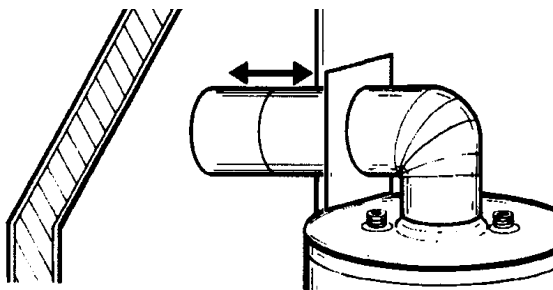

FIGURE 68.

19. Push the vent collar from the elbow against the wall and secure with the four provided screws.

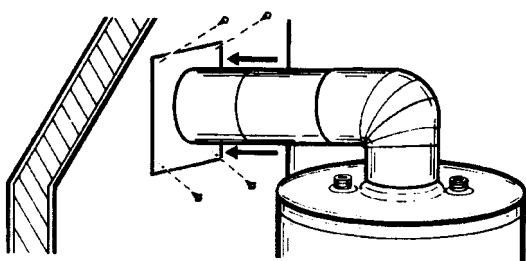

FIGURE 69.

20. Secure the 6" (15.2 cm) vent extension to the vent elbow with the two provided screws spacing them 180° apart.

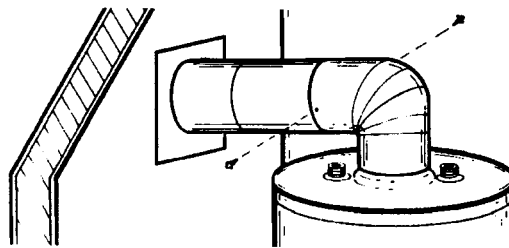
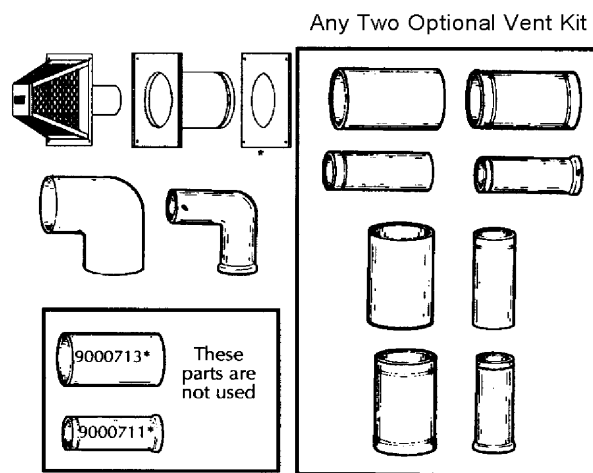

FIGURE 70.

Optional Vertical and Horizontal Vent Kit - Installation #4



* Each part is stamped with a part number

If the vent hole has not been cut, refer to section, "Cutting The Opening Through The Outside Wall." See page 11.

1. First determine how far the vertical 3" (7.6 cm) diameter telescoping flue sections are to be set and locked together with two screws supplied.

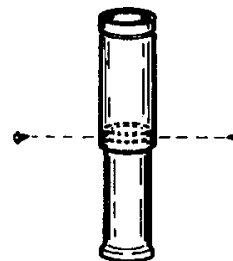

FIGURE 71.

Use the Chart #4, and figure 72 to determine the length of expansion of the telescoping flue sections. Because of manufacturing tolerances, put the telescoping extension on the water heater, adjust the height (dimension "X") and mark the point. Once the length has been determined, lock the two sections together by drilling two holes (180° apart) in the pipe and secure with the supplied screws.

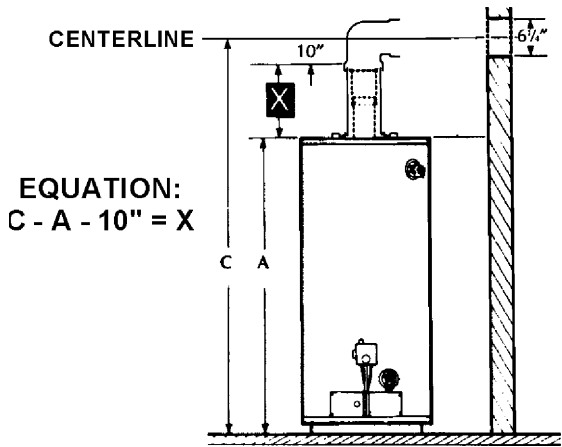

FIGURE 72.

EQUATION:
 $C - A - 10" = X$

CHART #4.

*GAL CAP	*BTU's in 1000's - NAT./L.P.	A	
40	36/36	48 3/4"	124 cm
50	38/38	57 1/2"	146 cm
40	40/40	48 3/4"	124 cm
50	48/44	61"	155 cm
75	55 NAT.	63"	160 cm

*Check the model and rating plate attached to the water heater for specific model number and other detailed information.

- Set the vertical 3" (7.6 cm) diameter telescoping flue section in place on the flue collar. Using a #22 drill bit, drill two holes (180° apart) and secure the vertical assembly to the flue collar with the two supplied screws.

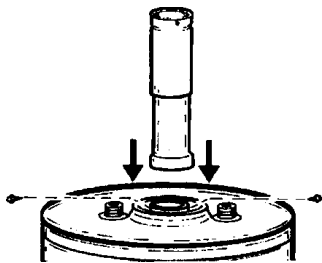

FIGURE 73.

- Slide the 6" (15.2 cm) vent telescoping section apart to reveal the beads. Fill the beads using the supplied caulking.

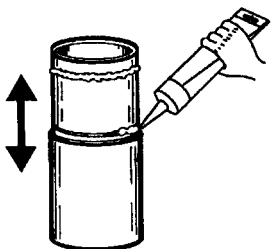

FIGURE 74.

- Apply an ample amount of sealant around the oval flare of the jacket.

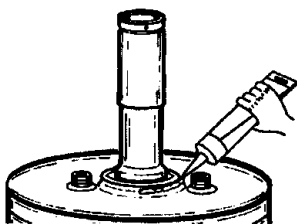

FIGURE 75.

- Place the 6" (15.2 cm) vent section over the 3" (7.6 cm) flue section. Subtract 3/4" (1.9 cm) from the predetermined "X" dimension. This determines the length of the 6" (15.2 cm) vent extension. Slide the 6" (15.2 cm) vent extension apart to this dimension and secure with the two screws supplied.

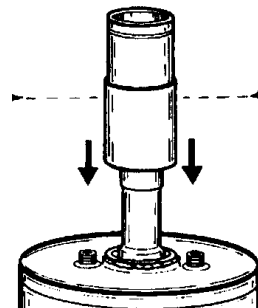

FIGURE 76.

- Form the round end of the 6" (15.2 cm) vent extension to the top of the jacket and secure with four sheet metal screws.

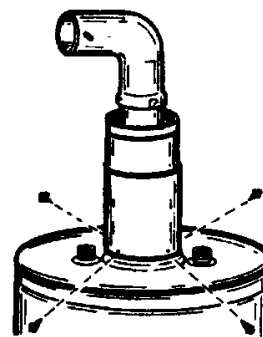

FIGURE 77.

- Place the 3" (7.6 cm) elbow on the flue extension. Align the elbow to the hole previously made in the outside wall. Using the slots in the elbow, mark the 3" (7.6 cm) diameter end of the flue extension. Using a #22 drill bit, drill two holes into the flue extension and secure with the two provided sheet metal screws.

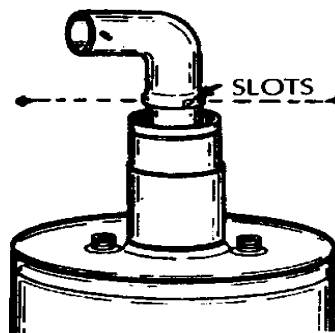

FIGURE 78.

NOTE: the standard kit includes a 3" (7.6 cm) flue extension and a 6" (15.2 cm) elbow extension. These parts will not be used with the horizontal kit.



8. Be sure the 6" (15.2 cm) diameter elbow is centered around the 3" (7.6 cm) diameter flue, secure using two sheet metal screws at the connection of the elbow and the 6" (15.2 cm) vertical extension.

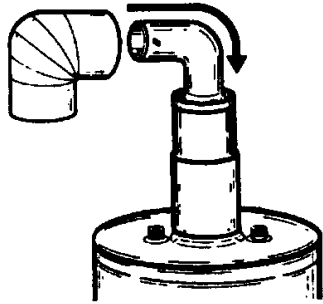

FIGURE 79.

9. Slide the vent collar (to be installed later) over the 6" (15.2 cm) vent elbow.

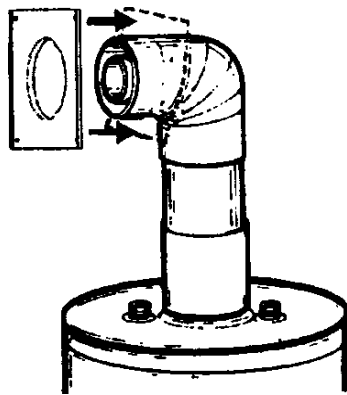

FIGURE 80.

10. Move the water heater into position at the vent opening.

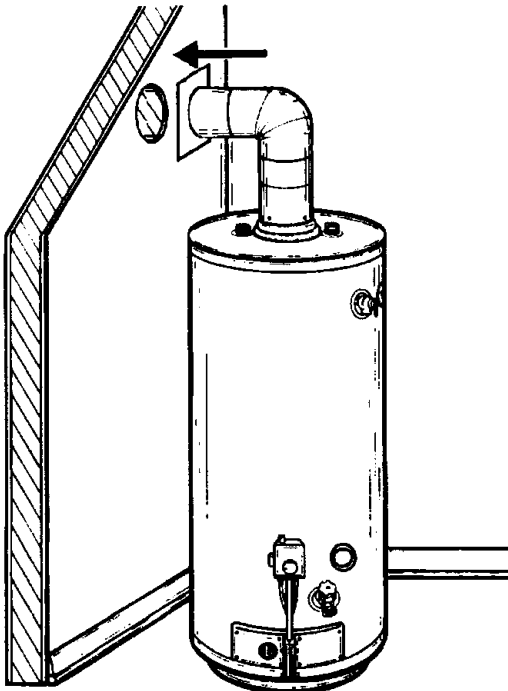

FIGURE 81.

11. Slide the 6" (15.2 cm) telescoping vent section apart to expose the beads. Use the supplied tube of caulking and fill the exposed beads.

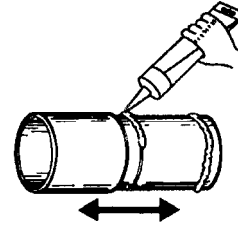

FIGURE 82.

12. Insert the 6" (15.2 cm) telescoping vent section into the wall.

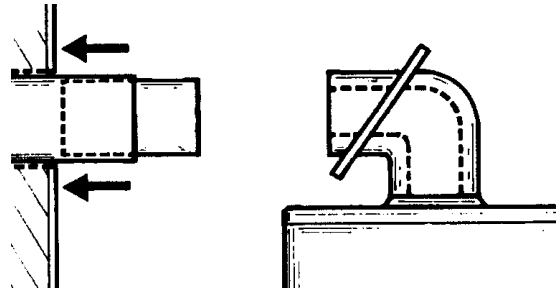

FIGURE 83.

13. The remaining vent parts will be installed from the outside. Apply ample amount of sealant to the inside surface of the collar assembly that will contact the exterior wall. Also, apply sealant to the bead around the outside edge at the end of the 6" (15.2 cm) diameter vent collar.

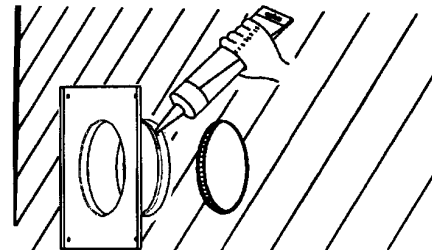

FIGURE 84.

14. Install the vent collar assembly through the wall, connecting to the 6" (15.2 cm) telescoping extension. Remember, the extension is not connected and may be necessary to return indoors to push the extension back against the interior wall for a tight fit to the collar.

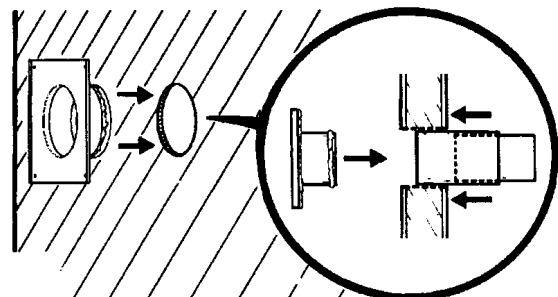

FIGURE 85.

15. Four wood screws were supplied to temporarily attach the collar to the exterior wall of the building. However, you may have to substitute other types of screws depending on the construction material of the exterior wall.

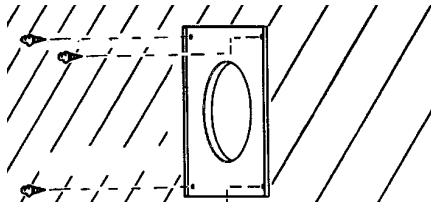

FIGURE 86.

16. Insert the vent cap into the vent collar assembly.

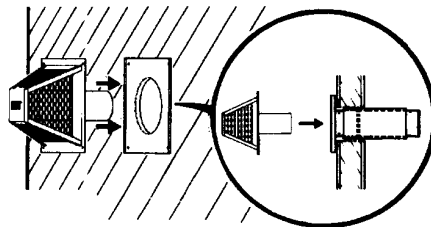

FIGURE 87.

17. The vent cap has four holes around the outer edge. Remove the four screws used to temporarily attach the collar to the exterior wall. Then secure the vent cap assembly with the vent collar assembly to the exterior wall using the same screws.

Note: Screws are supplied; however, substitution may be necessary depending on the exterior wall material.

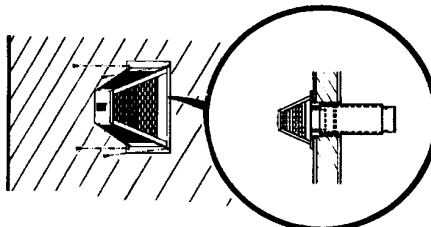

FIGURE 88.

18. The remainder of the installation will be conducted indoors to complete the assembly process.

19. Collapse the 6" extension assembly as shown below. Install the O-ring end of the 3" (7.6 cm) extension approximately 1 1/4" (3.2 cm) into the end of the vent cap. If necessary, apply a soap solution to the O-ring to ease the assembly. Rotate the extension clockwise until the other end is locked to the studs on the elbow.

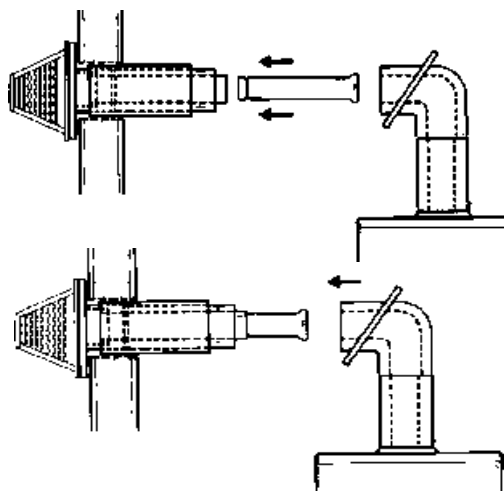

FIGURE 89.

20. Using a #22 drill bit, drill holes 180° apart at the connection point of the two 3" (76 mm) flue extensions. Secure with the two screws provided.

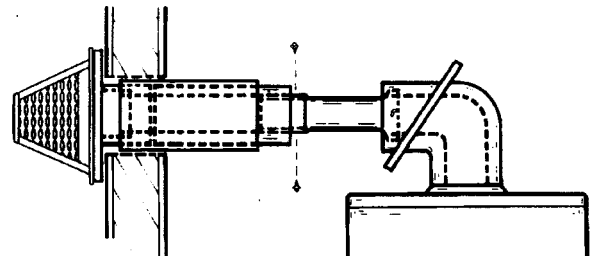

FIGURE 90.

21. Expand the 6" (152 mm) telescoping extension pipes to connect at the vent elbow.

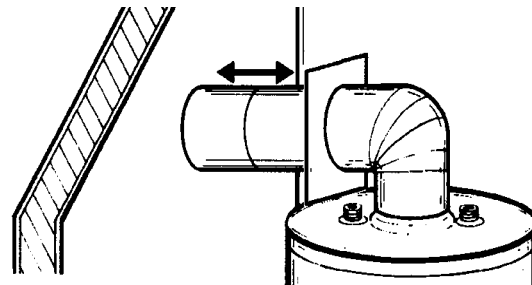

FIGURE 91.

22. Push the vent collar from the elbow against the wall and secure with the four provided screws.

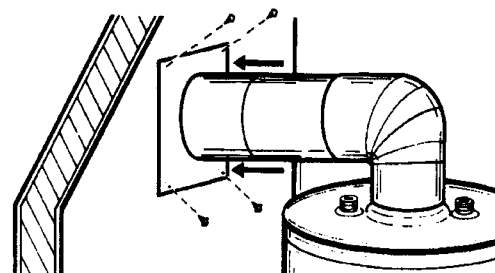

FIGURE 92.

23. Secure the 6" (152 mm) vent extension to the vent elbow with the two provided screws spacing them 180° apart.

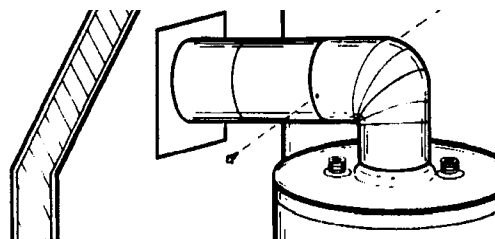

FIGURE 93.

Optional Vent Cap - Porcelain-Enameled

These supplementary installation instructions are applicable only if this direct vent water heater is provided with the alternate brown

porcelain-enameled vent cap assembly and the 6" (15.2 cm) vent wall assembly shown by Figure 94.

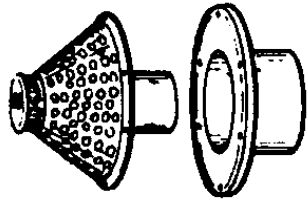

FIGURE 94.

The water heater model designation on the rating plate will have a suffix "P" to indicate this alternate vent cap assembly.

The alternate installation instructions below will replace the itemized instructions in the manual as follows: Items 11 thru 15 on page 13 and items 14 thru 18 on page 16.

1. Making sure the arrow points "UP", install the vent collar assembly through the wall, connecting it to the extension and/or elbow depending on which one was used.

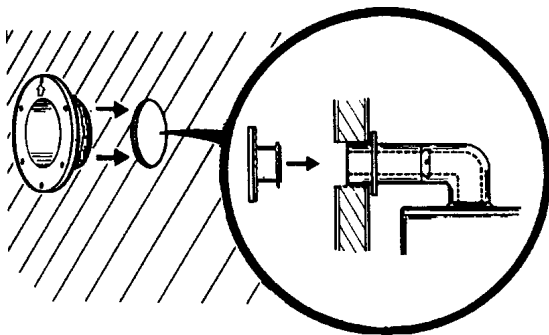

FIGURE 95.

2. Three wood screws are supplied to attach the collar to the exterior wall of the building. However, other types of screws may have to be substituted depending on the construction of the exterior wall.

NOTE: alternate screws used must not have a head larger than 3/8" (.95 cm).

The three screws must be placed at every other hole (120° apart) to secure the vent collar assembly to the outside wall.

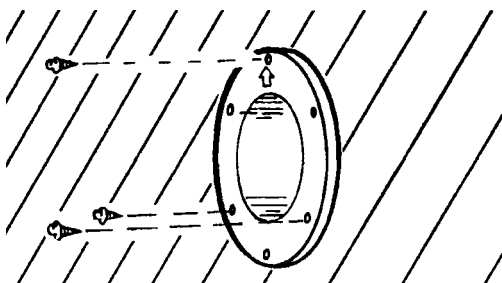

FIGURE 96.

16. Insert the 3" (7.6 cm) diameter flue extension pipe into the vent collar assembly (flared and notched end first). Lock the flue extension pipe to the flue elbow by rotating clockwise to lock studs to slots.

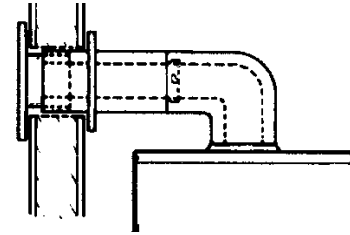

FIGURE 97.

4. Connect the vent cap by sliding it over the 3" (7.6 cm) diameter extension pipe and O-ring.

NOTE: for ease of assembly of the vent cap to the 3" (7.6 cm) pipe a soap solution can be applied to the O-ring gasket.

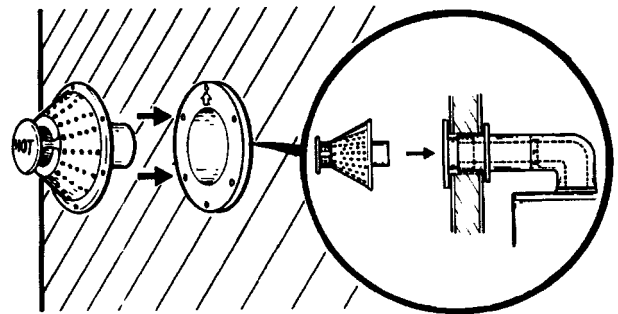

FIGURE 98.

5. The vent cap has six holes around the outer edge. The three larger ones are to fit over the three screws securing the vent collar assembly to the exterior wall. The three smaller ones will now be used to attach the vent cap assembly.

NOTE: screws are supplied. However, substitution may be necessary depending on the exterior wall material.

CAUTION

To prevent unlocking the previously installed 3" (7.6 cm) diameter extension, the vent cap assembly must be rotated in a clockwise motion when the vent cap is installed.

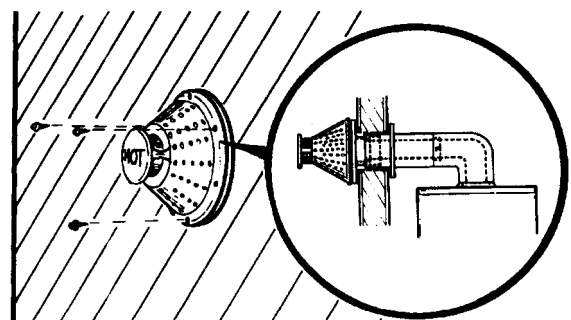

FIGURE 99.

The following alternate illustrated instructions will replace the itemized instructions in the manual as follows: Items 11 through 14 on page 18 and Items 14 through 17 on pages 21 and 22.

1. Making sure the arrow points "up", install the vent collar assembly through the wall, connecting it to the 6" (15.2 cm) telescoping extension. Remember, the extension is not connected, and it may be necessary to return indoors to push the extension back against the interior wall for a tight fit to the collar.

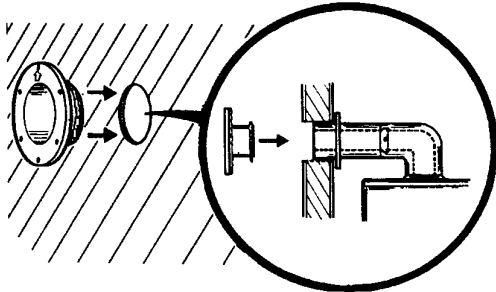

FIGURE 100.

2. Three wood screws are supplied to attach the collar to the exterior wall of the building. However, other types of screws may be substituted depending on the construction of the exterior wall.

NOTE: alternate screws used must not have heads larger than 3/8" (.95 cm).

The three screws must be placed at every other hole 120° apart to secure the vent collar assembly to the outside wall.

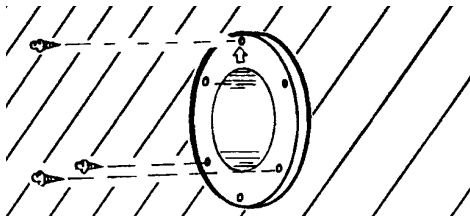

FIGURE 101.

3. Insert the vent cap in the vent collar assembly.

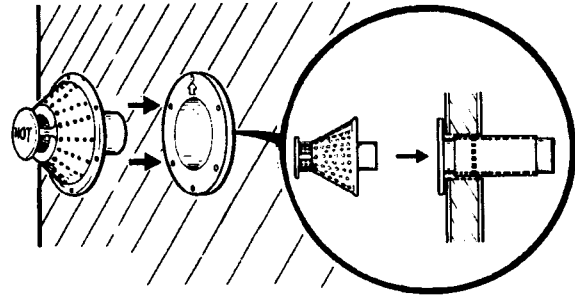

FIGURE 102.

4. The vent cap has six holes around its outer edge. The three larger ones are to fit over the three screws securing the vent collar assembly to the exterior wall. The three smaller ones will now be used to attach the vent cap assembly.

NOTE: screws are supplied. However, substitution may be necessary, depending on the exterior wall material.

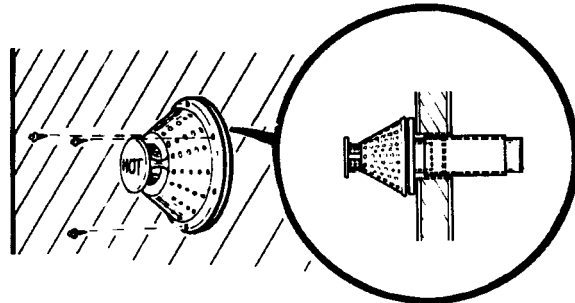

FIGURE 103.

INSTALLING THE NEW WATER HEATER

WATER PIPING

⚠ DANGER

Water temperature over 125°F (52°C) can cause severe burns instantly resulting in severe injury or death.

Children, the elderly, and the physically or mentally disabled are at highest risk for scald injury.

Feel water before bathing or showering.

Temperature limiting valves are available.

Read instruction manual for safe temperature setting.

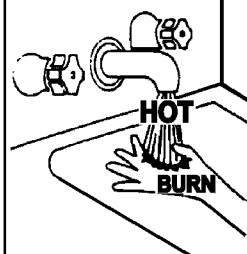

HOTTER WATER CAN SCALD:

Water heaters are intended to produce hot water. Water heated to a temperature which will satisfy space heating, clothes washing, dish washing, cleaning and other sanitizing needs can scald and permanently injure you upon contact. Some people are more likely to be permanently injured by hot water than others. These include the elderly, children, the infirm, or physically/mentally handicapped. If anyone using hot water in your home fits into one of these groups or if there is a local code or state law requiring a certain temperature water at the hot water tap, then you must take special precautions. In addition to using the lowest possible temperature setting that satisfies your hot water needs, a means such as a *mixing valve, shall be used at the hot water taps used by these people or at the water heater, see Figure. Valves for reducing point of use temperature by mixing cold and hot water are also available. Consult a Qualified Installer or Service Agency. Follow manufacturer's instructions for installation of the valves. Before changing the factory setting on the thermostat, read the "Temperature Regulation" section in this manual.

⚠ WARNING

Toxic Chemical Hazard

- Do not connect to non-potable water system.

This water heater shall not be connected to any heating systems or component(s) used with a non-potable water heating appliance.

All piping components connected to this unit for space heating applications shall be suitable for use with potable water.

Toxic chemicals, such as those used for boiler treatment shall not be introduced into this system.

When the system requires water for space heating at temperatures higher than required for domestic water purposes, a tempering valve must be installed. Please refer to Figure 2 for suggested piping arrangement.

Water supply systems may, because of such events as high line pressure, frequent cut-offs, the effects of water hammer among others, have installed devices such as pressure reducing valves, check valves, back flow preventers, etc. to control these types of problems. When these devices are not equipped with an internal by-pass, and no other measures are taken, the devices cause the water system to be closed.

As water is heated, it expands (thermal expansion) and closed systems do not allow for the expansion of heated water.

The water within the water heater tank expands as it is heated and increases the pressure of the water system. If the relieving point of the water heater's temperature-pressure relief valve is reached, the valve will relieve the excess pressure. **The temperature-pressure relief valve is not intended for the constant relief of thermal expansion.** This is an unacceptable condition and must be corrected. It is recommended that any devices installed which could create a closed system have a by-pass and/or the system have an expansion tank to relieve the pressure built by thermal expansion in the water system. Expansion tanks are available for ordering through a local plumbing contractor. Contact the local water supplier and/or a service agency for assistance in controlling these situations.

NOTE: To protect against untimely corrosion of hot and cold water fittings, it is strongly recommended that di-electric unions or couplings be installed on this water heater when connected to copper pipe.

CAUTION

Property Damage Hazard

- Avoid water heater damage.
- Install thermal expansion tank if necessary.
- Do not apply heat to cold water inlet.
- Contact qualified installer or service agency.

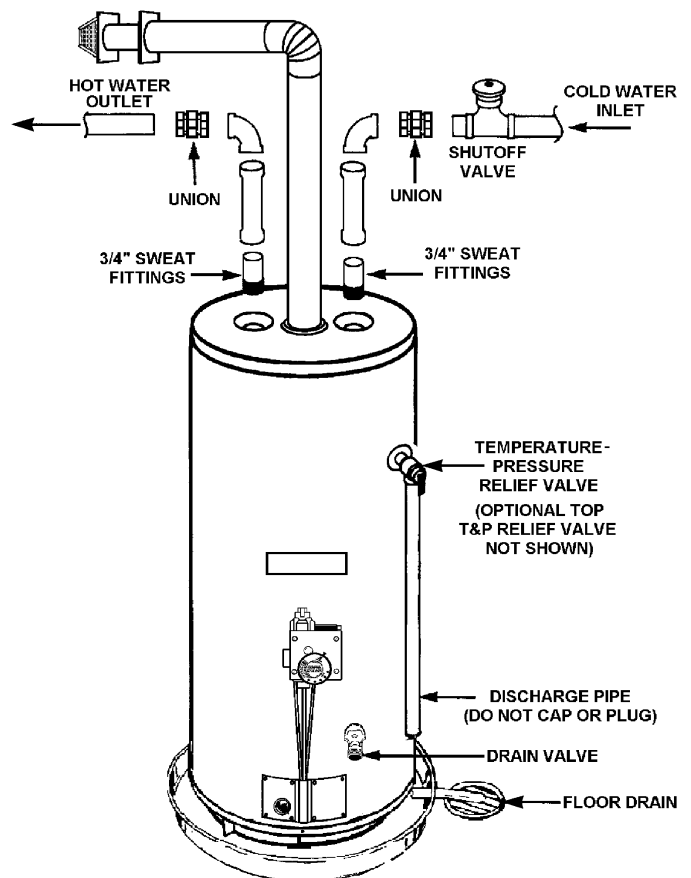

FIGURE 104.

Figure 104 shows the typical attachment of the water piping to the water heater. The water heater is equipped with 3/4 inch NPT water connections.

NOTE: If using copper tubing, solder tubing to an adapter before attaching the adapter to the cold water inlet connection. Do not solder the cold water supply line directly to the cold water inlet. It will harm the dip tube and damage the tank.

T & P Valve and Pipe Insulation

Remove insulation for T & P valve and pipe connections from carton.

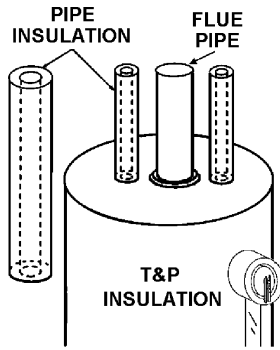

FIGURE 105.

Fit pipe insulation over the incoming cold water line and the hot water line. Make sure that the insulation is against the top cover of the heater. Fit T & P valve insulation over valve. Make sure that the insulation does not interfere with the lever of the T & P valve.

Secure all insulation using tape.

TEMPERATURE-PRESSURE RELIEF VALVE

	<h2>⚠ WARNING</h2> <h3>Explosion Hazard</h3>
	<ul style="list-style-type: none"> • Temperature-pressure relief valve must comply with ANSI Z21.22 and ASME code. • Properly sized temperature-relief valve must be installed in opening provided. • Can result in overheating and excessive tank pressure. • Can cause serious injury or death.

This heater is provided with a properly certified combination temperature - pressure relief valve by the manufacturer.

The valve is certified by a nationally recognized testing laboratory that maintains periodic inspection of production of listed equipment of materials as meeting the requirements for Relief Valves and Automatic Gas Shut-off Devices for Hot Water Supply Systems, ANSI Z21.22 • CSA 4.4, and the code requirements of ASME.

If replaced, the valve must meet the requirements of local codes, but not less than a combination temperature and pressure relief valve certified as indicated in the above paragraph.

The valve must be marked with a maximum set pressure not to exceed the marked hydrostatic working pressure of the water heater (150 psi = 1,035 kPa) and a discharge capacity not less than the water heater input rate as shown on the model rating plate.

For safe operation of the water heater, the relief valve must not be removed from its designated opening nor plugged.

The temperature-pressure relief valve must be installed directly into the fitting of the water heater designed for the relief valve. Position the valve downward and provide tubing so that any discharge will exit only within 6 inches (153 mm) above, or at any distance below the structural floor. Be certain that no contact is made with any live electrical part. The discharge opening must not be blocked or reduced in size under any circumstances. Excessive length, over 30 feet (9.14 m), or use of more than four elbows can cause restriction and reduce the discharge capacity of the valve, see Figure 106.

No valve or other obstruction is to be placed between the relief valve and the tank. Do not connect tubing directly to discharge drain unless a 6 inch air gap is provided. To prevent bodily injury, hazard to life, or property damage, the relief valve must be allowed to discharge water in quantities should circumstances demand. If the discharge pipe is not connected to a drain or other suitable means, the water flow may cause property damage.

<h2>CAUTION</h2> <h3>Water Damage Hazard</h3>
<ul style="list-style-type: none"> • Temperature-pressure relief valve discharge pipe must terminate at adequate drain.

The Discharge Pipe:

- Shall not be smaller in size than the outlet pipe size of the valve, or have any reducing couplings or other restrictions.
- Shall not be plugged or blocked.
- Shall be of material listed for hot water distribution.
- Shall be installed so as to allow complete drainage of both the temperature-pressure relief valve, and the discharge pipe.
- Shall terminate at an adequate drain.
- Shall not have any valve between the relief valve and tank.

	<h2>⚠ DANGER</h2>
	<p>Water temperature over 125°F (52°C) can cause severe burns instantly resulting in severe injury or death.</p> <p>Children, the elderly, and the physically or mentally disabled are at highest risk for scald injury.</p> <p>Feel water before bathing or showering.</p> <p>Temperature limiting valves are available.</p> <p>Read instruction manual for safe temperature setting.</p>

The temperature-pressure relief valve must be manually operated at least once a year. Caution should be taken to ensure that (1) no one is in front of or around the outlet of the temperature-pressure relief valve discharge line, and (2) the water manually discharged will not cause any bodily injury or property damage because the water may be extremely hot.

If after manually operating the valve, it fails to completely reset and continues to release water, immediately close the cold water inlet to the water heater, follow the draining instructions, and replace the temperature-pressure relief valve with a new one.

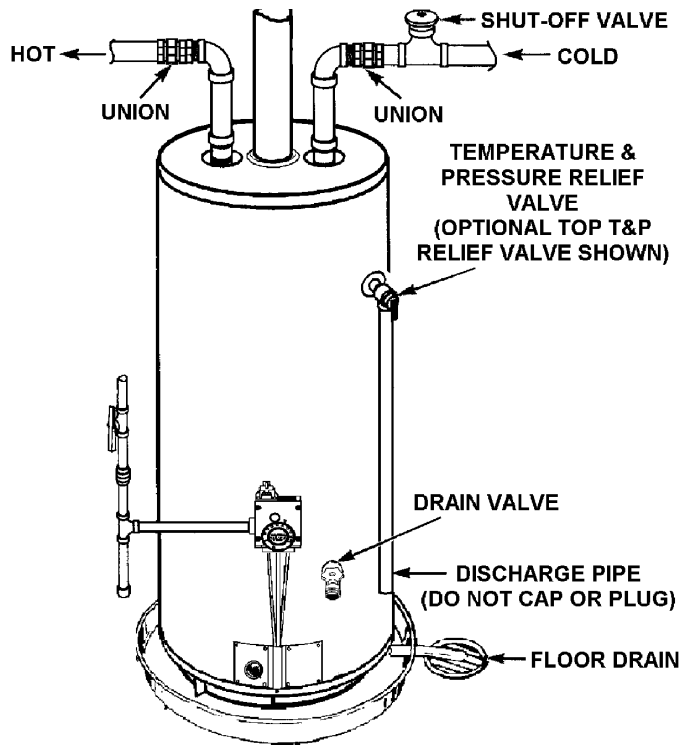

FIGURE 106.

FILLING THE WATER HEATER

CAUTION
Property Damage Hazard
<ul style="list-style-type: none"> • Avoid water heater damage. • Fill tank with water before operating.

Never use this water heater unless it is completely full of water. To prevent damage to the tank, the tank must be filled with water. Water must flow from the hot water faucet before turning "ON" gas to the water heater.

To fill the water heater with water:

1. Close the water heater drain valve by turning the handle to the right (clockwise). The drain valve is on the lower front of the water heater.
2. Open the cold water supply valve to the water heater. **NOTE:** The cold water supply valve must be left open when the water heater is in use.
3. To insure complete filling of the tank, allow air to exit by opening the nearest hot water faucet. Allow water to run until a constant flow is obtained. This will let air out of the water heater and the piping.
4. Check all water piping and connections for leaks. Repair as needed.

GAS PIPING

	WARNING
	Fire and Explosion Hazard
	<ul style="list-style-type: none"> • Do not use water heater with any gas other than the gas shown on the rating plate. • Excessive pressure to gas control valve can cause serious injury or death. • Turn off gas lines during installation. • Contact qualified installer or service agency.

Make sure the gas supplied is the same type listed on the model rating plate. The inlet gas pressure must not exceed 14 inch water column (2.6 kPa) for natural and propane gas (L.P.). The minimum inlet gas pressure shown on the rating plate is that which will permit firing at rated input.

If the gas control valve is subjected to pressures exceeding 1/2 pound per square inch (3.5 kPa), the damage to the gas control valve could result in a fire or explosion from leaking gas.

If the main gas line Shut-off serving all gas appliances is used, also turn "off" the gas at each appliance. Leave all gas appliances shut "off" until the water heater installation is complete.

A gas line of sufficient size must be run to the water heater. Consult the current edition of National Fuel Gas Code ANSI Z223.1/NFPA 54 and your gas supplier concerning pipe size.

There must be:

- A readily accessible manual shut off valve in the gas supply line serving the water heater, and
- A drip leg (sediment trap) ahead of the gas control valve to help prevent dirt and foreign materials from entering the gas control valve.
- A flexible gas connector or a ground joint union between the shut off valve and control valve to permit servicing of the unit.

Be sure to check all the gas piping for leaks before lighting the water heater. Use a soapy water solution, not a match or open flame. Rinse off soapy solution and wipe dry.

WARNING	
Breathing Hazard - Carbon Monoxide Gas	
	<ul style="list-style-type: none"> • High altitude orifice must be installed for operation above 2000 feet. • Contact a qualified installer or service agency.
Breathing carbon monoxide can cause brain damage or death. Always read and understand instruction manual.	

When installed at elevations above 2,000 feet (610 meters), input rating should be reduced at the rate of 4 percent for each 1,000 feet (305 meters) above sea level which requires replacement of the burner orifice in accordance with National Fuel Gas Code ANSI Z223.1/NFPA 54. Contact your local gas supplier for further information.

Failure to replace the standard orifice with a high altitude orifice when installed could result in improper and inefficient operation of the appliance, producing carbon monoxide gas in excess of safe limits, which could result in serious injury or death. Contact your gas supplier for any specific changes which may be required in your area.

	<h2>⚠ WARNING</h2>
	<h3>Fire and Explosion Hazard</h3> <ul style="list-style-type: none"> • Use joint compound or tape compatible with propane. • Leak test before operating heater. • Disconnect gas piping and shut-off valve before pressure testing system.

Use pipe joint compound or teflon tape marked as being resistant to the action of petroleum [Propane (L.P.)] gases.

The appliance and its gas connection must be leak tested before placing the appliance in operation.

The appliance and its individual Shut-off valve shall be disconnected from the gas supply piping system during any pressure testing of that system at test pressures in excess of 1/2 pound per square inch (3.5 kPa). It shall be isolated from the gas supply piping system by closing its individual manual Shut-off valve during any pressure testing of the gas supply piping system at test pressures equal to or less than 1/2 pound per square inch (3.5 kPa).

Connecting the gas piping to the gas control valve of the water heater can be accomplished by either of the two methods shown in Figures 107 and 108.

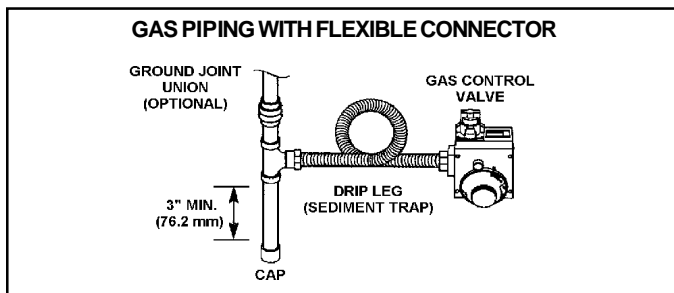

FIGURE 107.

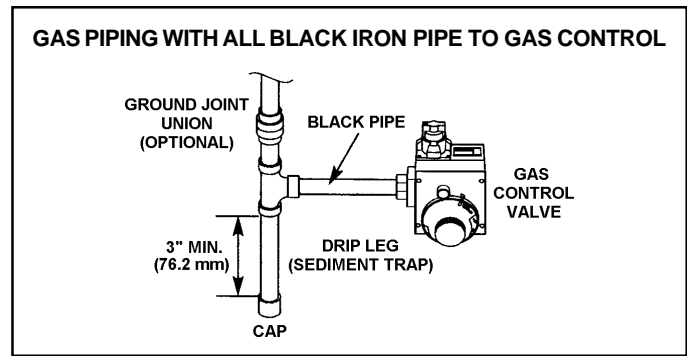



FIGURE 108.

SEDIMENT TRAPS

	<h2>⚠ WARNING</h2>
	<h3>Fire and Explosion Hazard</h3> <ul style="list-style-type: none"> • Contaminants in gas lines can cause fire or explosion. • Clean all gas piping before installation. • Install drip leg in accordance with NFPA54.

A sediment trap shall be installed as close to the inlet of the water heater as practical at the time of water heater installation. The sediment trap shall be either a tee fitting with a capped nipple in the bottom outlet or other device recognized as an effective sediment trap. If a tee fitting is used, it shall be installed in conformance with one of the methods of installation shown in Figures 107 and 108.

Contaminants in the gas lines may cause improper operation of the gas control valve that may result in fire or explosion. Before attaching the gas line be sure that all gas pipe is clean on the inside. To trap any dirt or foreign material in the gas supply line, a drip leg (sometimes called a sediment trap) must be incorporated in the piping. The drip leg must be readily accessible. Install in accordance with the "Gas Piping" section. Refer to the current edition of the National Fuel Gas Code, ANSI Z223.1/NFPA 54.

INSTALLING THE NEW WATER HEATER (cont'd.)

INSTALLATION CHECKLIST

BEFORE LIGHTING THE PILOT:

1. Check the gas line for leaks.
 - a. Use a soapy water solution. DO NOT test for gas leaks using a match or open flame.
 - b. Brush the soapy water solution on all gas pipes, joints and fittings.
 - c. Check for bubbling soap. This means you have a leak. Turn "OFF" gas and make the necessary repairs.
 - d. Recheck for leaks.
 - e. Rinse off soapy solution and wipe dry.
2. Is this new temperature-pressure relief valve properly installed and piped to an adequate drain? See "Temperature-Pressure Relief Valve" section.
3. Are the cold and hot water lines connected to the water heater correctly? See "Water Piping" instructions in the "Installing the New Water Heater" section.
4. Is the water heater completely filled with water? See "Filing the Water Heater" instructions in the "Installing the New Water Heater" section.
5. Will a water leak damage anything? See the "Locating the New Water Heater" section.
6. Is there proper clearance between the water heater and anything that might catch fire? See the "Locating the New Water Heater" section.
7. Do you have adequate ventilation so that the water heater will operate properly? See "Combustion Air and Ventilation" in the "Locating the New Water Heater" section.
8. Is the vent piping properly secured? See "Venting" instructions in the "Installing the New Water Heater" section.
9. Is there proper clearance between the vent pipe and anything that might catch fire? See "Venting" instructions in the "Installing the New Water Heater" section.
10. Is the vent pipe properly sloped and does the vent terminate outdoors? See "Venting" instructions in the "Installing the New Water Heater" section.
11. Do you need to call your gas company to check the gas pipe and its hookup?

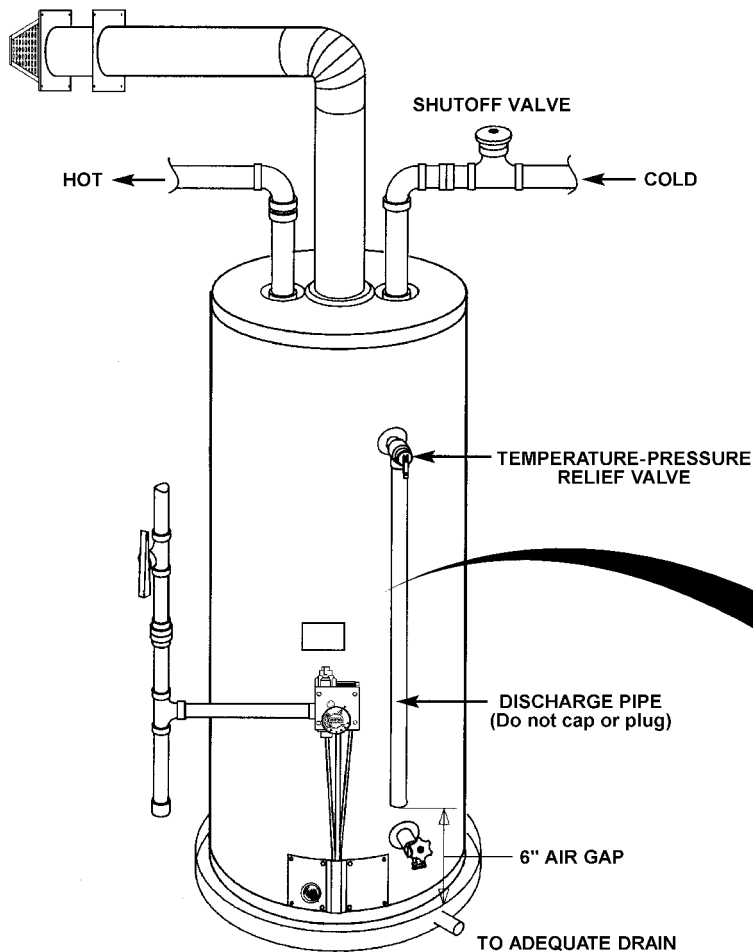

MODEL RATING PLATE

DIRECT VENT AUTOMATIC STORAGE WATER HEATER							
MODEL NUMBER	CAPACITY	GAS TYPE	ITEM ID				
INPUT BTU/HR		RECOVERY GAL/HR		SERIAL NUMBER			
GAS PRESSURES IN. W.C.		MAX WORKING		BUILD DATE			
MANIFOLD	MAX INLET	MIN INLET	PRESSURE P.S.I.				

FOR YOUR SAFETY READ BEFORE LIGHTING

WARNING

If you do not follow these instructions exactly, a fire or explosion may result causing property damage, personal injury or loss of life.

- A. This appliance has a pilot which is lit by a piezo-electric spark gas ignition system. Do not remove the access doors of the appliance and try to light the pilot by hand.
- B. BEFORE LIGHTING smell all around the appliance area for gas. Be sure to smell next to the floor because some gas is heavier than air and will settle on the floor.
- WHAT TO DO IF YOU SMELL GAS**
- Do not try to light any appliance.
 - Do not touch any electric switch; do not use any phone in your building.
 - Immediately call your gas supplier from a neighbor's phone. Follow the gas supplier's instructions.
- C. If you cannot reach your gas supplier, call the fire department.
- C. Use only your hand to push in or turn the gas control knob. Never use tools. If the knob will not push in or turn by hand, don't try to repair it, call a qualified service technician. Force or attempted repair may result in a fire or explosion.
- D. Do not use this appliance if any part has been under water. Immediately call a qualified installer or service agency to replace a flooded water heater. Do not attempt to repair the unit! It must be replaced!

LIGHTING INSTRUCTIONS

1. STOP! Read the safety information above on this label.
2. Set the thermostat to lowest setting (PILOT LIGHTING). Turn the thermostat dial fully clockwise (↻) until it stops as shown.

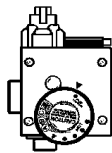

3. Turn gas control knob clockwise (↻) to "OFF" position. Knob cannot be turned from "PILOT" to "OFF" unless knob is depressed slightly. **DO NOT FORCE.**
4. Wait five (5) minutes to clear out any gas. If you then smell gas, STOP! Follow "B" in the safety information above on this label. If you don't smell gas, go to the next step.
5. If you don't smell gas, turn knob on gas control counter clockwise (↺) to "PILOT" position.
6. Pilot can be viewed through observation port. Note location of piezo ignitor.

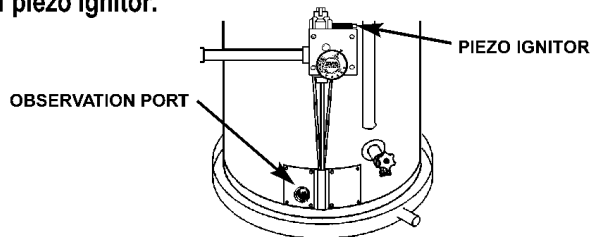

7. Depress the gas control knob all the way down. Immediately depress the piezo ignitor button until a click is heard and then release. Check to see if pilot is lit through the observation port. If pilot is not lit, continue to depress and release piezo ignitor button up to six (6) times. If pilot is still not lit, repeat steps 3 through 7. After the pilot is lit, continue to hold control knob down for about one (1) minute. Release knob and it will pop backup. Pilot should remain lit. If it goes out repeat steps 2 through 7.
- If knob does not pop up when released, stop and immediately call your service technician or gas supplier.
- If the pilot will not stay lit after several tries, depress and turn the gas control knob clockwise (↻) to "OFF" and call your service technician or gas supplier.
8. Turn gas control knob counter-clockwise (↺) to the full "ON" position. **WARNING Do not use gas control knob to regulate gas flow.**
9. Set the thermostat to desired setting. The mark (▲) indicative of approximately 120°F is preferred starting point. Some local laws may require a lower starting point. If hotter water is desired, see instruction manual and "warning" below.

WARNING

Hotter water increases the risk of scald injury. Before changing temperature setting see instruction manual.

TO TURN OFF GAS TO APPLIANCE

1. Set the thermostat to lowest setting (PILOT LIGHTING). Turn the thermostat dial fully clockwise (↻) until it stops as shown.

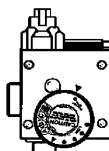

2. Turn gas control knob clockwise (↻) to "OFF" position. Knob cannot be turned from "PILOT" to "OFF" unless knob is depressed slightly. **DO NOT FORCE**

TEMPERATURE REGULATION

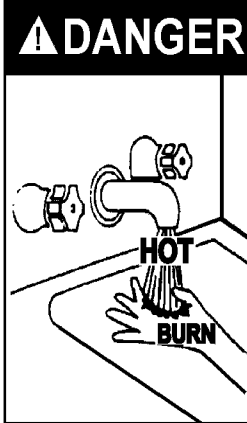

⚠ DANGER Water temperature over 125°F (52°C) can cause severe burns instantly resulting in severe injury or death.

Children, the elderly, and the physically or mentally disabled are at highest risk for scald injury.

Feel water before bathing or showering.

Temperature limiting valves are available.

Read instruction manual for safe temperature setting.

HOT WATER CAN SCALD: Water heaters are intended to produce hot water. Water heated to a temperature that will satisfy space heating, clothes washing, dish washing, and other sanitizing needs can scald and permanently injure you upon contact. Some people are more likely to be permanently injured by hot water than others. These include the elderly, children, the infirm, or physically/mentally handicapped. If anyone using hot water in your home fits into one of these groups or if there is a local code or state law requiring a specific hot water temperature at the tap, then you must take special precautions. Never allow small children to use a hot water tap, or to draw their own bath water. Never leave a child or handicapped person unattended in a bathtub or shower.

It is recommended that lower water temperatures be used to avoid the risk of scalding. It is further recommended, in all cases, that the water temperature be set for the lowest temperature that satisfies your hot water needs. This will also provide the most energy efficient operation of the water heater.

Figure 110 shows the approximate water temperatures produced at various thermostat settings. Short repeated heating cycles caused by small hot water uses can cause temperatures at the point of use to exceed the thermostat setting by up to 30°F (17°C). If you experience this type of use you should consider using lower temperature settings to reduce scald hazards.

Valves for reducing the point-of-use temperature by mixing cold and hot water are available. See Figure 2. Also available are inexpensive devices that attach to faucets to limit hot water temperatures. Contact a licensed plumber or the local plumbing authority.

NOTE: A water temperature range of 120°F-140°F (49°C-60°C) is recommended by most dishwasher manufacturers.

The thermostat of this water heater has been factory set at its lowest position (PILOT LIGHTING). It is adjustable and must be reset to the desired temperature setting to reduce the risk of scald injury. The mark (▲) indicative of approximately 120°F (49°C) is preferred starting point. Some States have a requirement for a lower setting.

Turn the water temperature dial clockwise (↻) to decrease the temperature, or counterclockwise (↺) to increase the temperature.

Should overheating occur or the gas supply fail to shut off, turn off the manual gas control valve to the appliance.

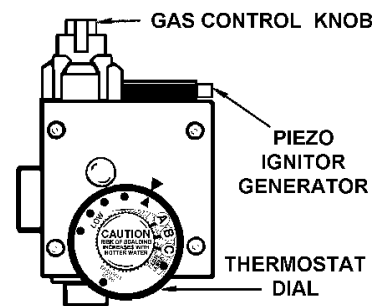

FIGURE 109.

Temperature Settings	Time to Produce 2nd & 3rd Degree Burns on Adult Skin
VERY HOT = approx. 160°F (71°C)	About 1/2 second
C = approx. 150°F (66°C)	About 1-1/2 seconds
B = approx. 140°F (60°C)	Less than 5 seconds
A = approx. 130°F (54°C)	About 30 seconds
▲ = approx. 120°F (49°C)	More than 5 minutes
LOW = approx. 80°F (27°C)	-----

FIGURE 110.

FOR YOUR INFORMATION

START UP CONDITIONS

CONDENSATE

Whenever the water heater is filled with cold water, some condensate will form while the burner is on. A water heater may appear to be leaking when in fact the water is condensation. This usually happens when:

- a. A new water heater is filled with cold water for the first time.
- b. Burning gas produces water vapor in water heaters, particularly high efficiency models where flue temperatures are lower.
- c. Large amounts of hot water are used in a short time and the refill water in the tank is very cold.

Moisture from the products of combustion condense on the cooler tank surfaces and form drops of water which may fall onto the burner or other hot surfaces to produce a "sizzling" or "frying" noise.

Excessive condensation can cause pilot outage due to water running down the flue tube onto the main burner and putting out the pilot. Because of the suddenness and amount of water, condensation water may be diagnosed as a "tank leak". After the water in the tank warms up (about 1-2 hours), the condition should disappear.

Do not assume the water heater is leaking until there has been enough time for the water in the tank to warm up.

An undersized water heater will cause more condensation. The water heater must be sized properly to meet the family's demands for hot water including dishwashers, washing machines and shower heads.

Excessive condensation may be noticed during the winter and early spring months when incoming water temperatures are at their lowest.

Good venting is essential for a gas fired water heater to operate properly as well as to carry away products of combustion and water vapor.

SMOKE/ODOR

It is not uncommon to experience a small amount of smoke and odor during the initial start-up. This is due to burning off of oil from metal parts, and will disappear in a short while.

THERMAL EXPANSION

CAUTION
Improper installation and use may result in property damage.
<ul style="list-style-type: none">• Avoid water heater damage.• Install thermal expansion tank or device if necessary.• Contact qualified installer or service agency.

Water supply systems may, because of such events as high line pressure, frequent cut-offs, the effects of water hammer among others, have installed devices such as pressure reducing valves, check valves, back flow preventers, etc. to control these types of problems. When these devices are not equipped with an internal by-pass, and no other measures are taken, the devices cause the water system to be closed. As water is heated, it expands (thermal expansion) and closed systems do not allow for the expansion of heated water.

The water within the water heater tank expands as it is heated and increases the pressure of the water system. If the relieving point of the water heater's temperature-pressure relief valve is reached, the valve will relieve the excess pressure. **The temperature-pressure relief valve is not intended for the constant relief of thermal expansion.** This is an unacceptable condition and must be corrected. It is recommended that any devices installed which could create a closed system have a by-pass and/or the system have an expansion tank or device to relieve the pressure built by thermal expansion in the water system. Expansion tanks are available for ordering through a local plumbing contractor. Contact the local water heater supplier or service agency for assistance in controlling these situations.

STRANGE SOUNDS

Possible noises due to expansion and contraction of some metal parts during periods of heat-up and cool-down do not necessarily represent harmful or dangerous conditions.

Condensation causes sizzling and popping within the burner area during heating and cooling periods and should be considered normal. See "Condensation" in this section.

OPERATIONAL CONDITIONS

SMELLY WATER

In each water heater there is installed at least one anode rod (see parts sections) for corrosion protection of the tank. Certain water conditions

will cause a reaction between this rod and the water. The most common complaint associated with the anode rod is one of a "rotten egg smell" in the hot water. This odor is derived from hydrogen sulfide gas dissolved in the water. The smell is the result of four factors which must all be present for the odor to develop:

- a. A concentration of sulfate in the supply water.
- b. Little or no dissolved oxygen in the water.
- c. A sulfate reducing bacteria which has accumulated within the water heater (this harmless bacteria is nontoxic to humans).
- d. An excess of active hydrogen in the tank. This is caused by the corrosion protective action of the anode.

Smelly water may be eliminated or reduced in some water heater models by replacing the anode(s) with one of less active material, and then chlorinating the water heater tank and all hot water lines. Contact the local water heater supplier or service agency for further information concerning an Anode Replacement Kit and this chlorination treatment.

If the smelly water persists after the anode replacement and chlorination treatment, we can only suggest that chlorination or aeration of the water supply be considered to eliminate the water problem.

Do not remove the anode leaving the tank unprotected. By doing so, all warranty on the water heater tank is voided.

"AIR" IN HOT WATER FAUCETS

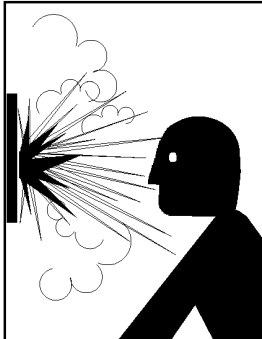
	⚠ WARNING
	Explosion Hazard
	<ul style="list-style-type: none">• Flammable hydrogen gases may be present.• Keep all ignition sources away from faucet when turning on hot water.

HYDROGEN GAS: Hydrogen gas can be produced in a hot water system that has not been used for a long period of time (generally two weeks or more). Hydrogen gas is extremely flammable and explosive. To prevent the possibility of injury under these conditions, we recommend the hot water faucet, located farthest away, be opened for several minutes before any electrical appliances which are connected to the hot water system are used (such as a dishwasher or washing machine). If hydrogen gas is present, there will probably be an unusual sound similar to air escaping through the pipe as the hot water faucet is opened. There must be no smoking or open flame near the faucet at the time it is open.

HIGH WATER TEMPERATURE SHUT OFF SYSTEM

This water heater is equipped with an automatic gas Shut-off system. This system works when high water temperatures are present. Turn "OFF" the entire gas supply to the water heater. The high temperature Shut-off is built into the gas control valve. It is non-resettable. If the high temperature Shut-off activates, the gas control valve must be replaced. Contact your gas supplier or service agency.

PERIODIC MAINTENANCE

VENTING SYSTEM INSPECTION

⚠ WARNING

Breathing Hazard - Carbon Monoxide Gas

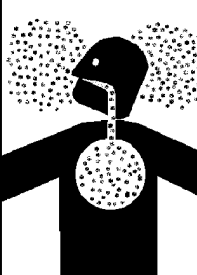

- Flue gases may escape if vent pipe is not connected.
- Be alert for obstructed, sooted or deteriorated vent system to avoid serious injury or death.
- Do not store corrosive chemicals in vicinity of water heater.
- Chemical corrosion of flue and vent system can cause serious injury or death.

Breathing carbon monoxide can cause brain damage or death.
Always read and understand instruction manual.

At least once a year a visual inspection should be made of the venting system. You should look for:

1. Obstructions which could cause improper venting. The combustion and ventilation air flow must not be obstructed.
2. Damage or deterioration which could cause improper venting or leakage of combustion products.
3. Rusted flakes around top of water heater.

Be sure the vent piping is properly connected to prevent escape of dangerous flue gasses which could cause deadly asphyxiation.

Obstructions and deteriorated vent systems may present serious health risk or asphyxiation.

Chemical vapor corrosion of the flue and vent system may occur if air for combustion contains certain chemical vapors. Spray can propellants, cleaning solvents, refrigerator and air conditioner refrigerants, swimming pool chemicals, calcium and sodium chloride, waxes, bleach and process chemicals are typical compounds which are potentially corrosive.

If after inspection of the vent system you found sooting or deterioration, something is wrong. Call the local gas utility to correct the problem and clean or replace the flue and venting before resuming operation of the water heater.

BURNER INSPECTION

Flood damage to a water heater may not be readily visible or immediately detectable. However, over a period of time a flooded water heater will create dangerous conditions which can cause DEATH, SERIOUS BODILY INJURY, OR PROPERTY DAMAGE. Contact a qualified installer or service agency to replace a flooded water heater. Do not attempt to repair the unit! It must be replaced!

At least once a year a visual inspection should be made of the main burner and pilot burner, see Figure 111.

You should check for sooting. Soot is not normal and will impair proper combustion.

Soot build-up indicates a problem that requires correction before further use. Turn "OFF" gas to water heater and leave off until repairs are made, because failure to correct the cause of the sooting can result in a fire causing death, serious injury, or property damage.

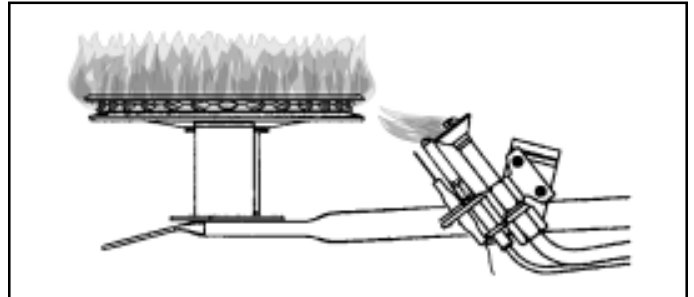

FIGURE 111.

BURNER CLEANING

In the event your burner needs cleaning, follow these instructions:

If inspection of the burner shows that cleaning is required, turn the gas control knob clockwise (↻) to the "OFF" position, depressing slightly.

NOTE: The knob cannot be turned from "PILOT" to "OFF" unless knob is depressed slightly. DO NOT FORCE.

Loose deposits on or around the burner can be removed by carefully using the hose of a vacuum cleaner inserted through the access doors of the water heater. If the burner needs to be removed for additional cleaning, call the local gas utility to remove and clean the burner and correct the problem that required the burner to be cleaned.

L.P. GAS CONTROL VALVE & BURNER ASSEMBLY

Propane (L.P.) gas control valve and burner assembly replacement information.

For Propane (L.P.) Gas Models Only:

Your water heater is equipped with a Propane (L.P.) gas control valve and a main burner assembly with left hand threads for the following fittings and their connections.

- The connection between the manifold and the gas control valve (A to B) are left hand threads.
- The connection between the main burner orifice and the manifold (C to D) are left hand threads.

For ordering these replacement parts, please refer to the "Repair Parts" section of this manual.

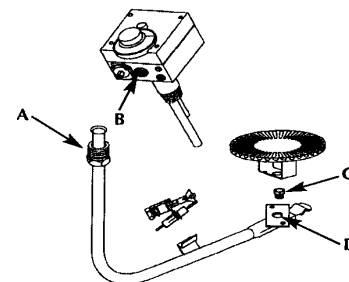



FIGURE 112.

HOUSEKEEPING

Vacuum around base of water heater for dust, dirt, and lint on a regular basis.

	⚠ DANGER
	Fire and Explosion Hazard
	<ul style="list-style-type: none">• Do not use or store flammable vapor products such as gasoline, solvents or adhesives in the same room or area near water heater or other appliance.• Can cause serious injury or death.

INSTALLED IN SUITABLE AREA: To insure sufficient ventilation and combustion air supply, proper clearances from the water heater must be maintained. See "Locating the New Water Heater" section. Combustible materials such as clothing, cleaning materials, or flammable liquids, etc. must not be placed against or adjacent to the water heater which can cause a fire.

ANODE ROD INSPECTION

CAUTION
Property Damage Hazard
<ul style="list-style-type: none">• Avoid water heater damage.• Inspection and replacement of anode rod required.

The anode rod is used to protect the tank from corrosion. Most hot water tanks are equipped with an anode rod. The submerged rod sacrifices itself to protect the tank. Instead of corroding the tank, water ions attack and eat away the anode rod. This does not affect the water's taste or color. The rod must be maintained to keep the tank in operating condition.

Anode deterioration depends on water conductivity, not necessarily water condition. A corroded or pitted anode rod indicates high water conductivity and should be checked and/or replaced more often than an anode rod that appears to be intact. Replacement of a depleted anode rod can extend the life of your water heater. Inspection should be conducted by a qualified technician, and at a minimum should be checked annually after the warranty period.

TEMPERATURE-PRESSURE RELIEF VALVE OPERATION

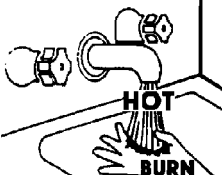
⚠ DANGER	<ul style="list-style-type: none">• Burn hazard.• Hot water discharge.• Keep clear of relief valve discharge outlet.
	

The temperature-pressure relief valve must be manually operated at least once a year.

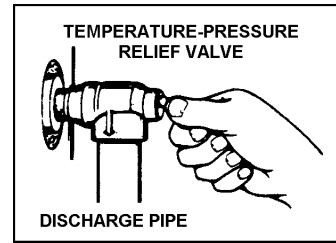

FIGURE 113.

When checking the temperature-pressure relief valve operation, make sure that (1) no one is in front of or around the outlet of the temperature-pressure relief valve discharge line, and (2) that the water discharge will not cause any property damage, as the water may be extremely hot, see Figure 113.

If after manually operating the valve, it fails to completely reset and continues to release water, immediately close the cold water inlet to the water heater, follow the draining instructions, and replace the temperature-pressure relief valve with a new one.

If the temperature-pressure relief valve on the appliance weeps or discharges periodically, this may be due to thermal expansion. You may have a check valve installed in the water line or a water meter with a check valve. Consult your local water supplier or service agency for further information. Do not plug the temperature-pressure relief valve.

DRAINING

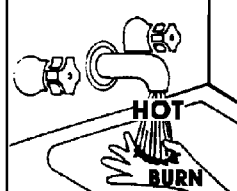
⚠ DANGER	<ul style="list-style-type: none">• Burn hazard.• Hot water discharge.• Keep hands clear of drain valve discharge.
	

The water heater should be drained if being shut down during freezing temperatures. Also periodic draining and cleaning of sediment from the tank may be necessary.

1. Turn the gas control knob to the "OFF" position.
2. CLOSE the cold water inlet valve to the water heater.
3. OPEN a nearby hot water faucet and leave open to allow for draining.
4. Connect a hose to the drain valve and terminate to an adequate drain.
5. OPEN the water heater drain valve to allow for tank draining.

NOTE: If the water heater is going to be shut down and drained for an extended period, the drain valve should be left open with hose connected allowing water to terminate to an adequate drain.

6. CLOSE the drain valve.
7. Follow instructions in the "Filling The Water Heater" section.
8. Follow the lighting instructions on the label, see page 29 under "Lighting Instructions" to restart the water heater.

DRAIN VALVE WASHER REPLACEMENT

(See Figure 114)

1. Turn "OFF" gas supply to water heater.
2. Follow "Draining" instructions.
3. Turning counterclockwise (↺), remove the hex cap below the screw handle.
4. Remove the washer and put the new one in place.
5. Screw the handle and cap assembly back into the drain valve and retighten using a wrench. **DO NOT OVER TIGHTEN.**
6. Follow instructions in the "Filling The Water Heater" section.
7. Check for leaks.

8. Follow the lighting instructions in the "Lighting" section to restart the water heater.

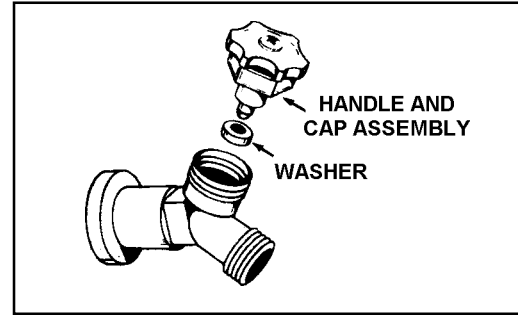
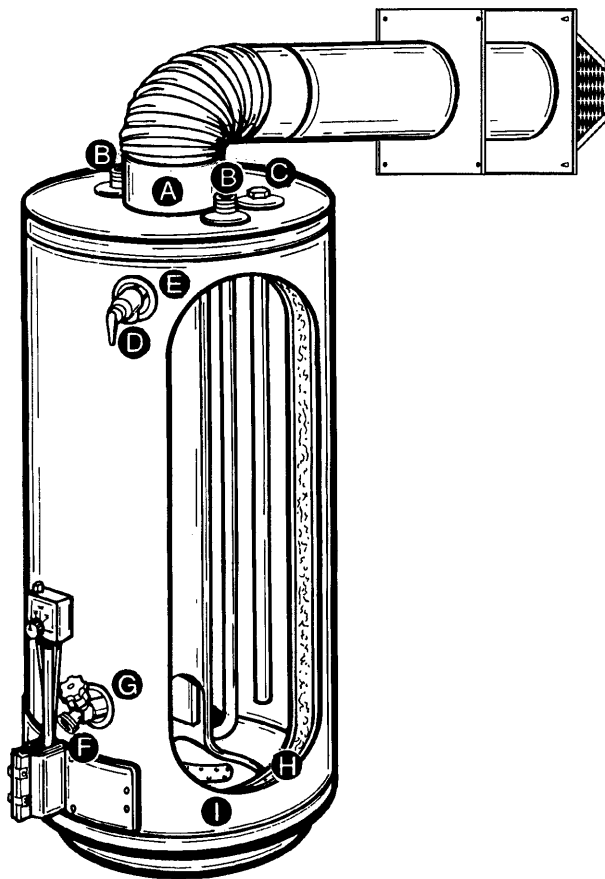

FIGURE 114.

LEAKAGE CHECKPOINTS



Read this manual first. Then before checking the water heater make sure the gas supply has been turned "OFF", and never turn the gas "ON" before the tank is completely full of water.

Never use this water heater unless it is completely filled with water. To prevent damage to the tank, the tank must be filled with water. Water must flow from the hot water faucet before turning "ON" gas to the water heater.

- A. Water at the draft hood is water vapor which has condensed out of the combustion products. This is caused by a problem in the vent. Contact the gas utility.
- B. *Condensation may be seen on pipes in humid weather or pipe connections may be leaking.
- C. *The anode rod fitting may be leaking.
- D. Small amounts of water from temperature-pressure relief valve may be due to thermal expansion or high water pressure in your area.
- E. *The temperature-pressure relief valve may be leaking at the tank fitting.
- F. Water from a drain valve may be due to the valve being slightly opened.
- G. *The drain valve may be leaking at the tank fitting.
- H. Combustion products contain water vapor which can condense on the cooler surfaces of the tank. Droplets form and drip onto the burner or run on the floor. This is common at the time of start-up after installation and when incoming water is cold.
- I. Water in the water heater bottom or on the floor may be from condensation, loose connections, or the relief valve. **DO NOT** replace the water heater until a full inspection of all possible water sources is made and necessary corrective steps taken.

Leakage from other appliances, water lines, or ground seepage should also be checked.

- * To check where threaded portion enters tank, insert cotton swab between jacket opening and fitting. If cotton is wet, follow "Draining" instructions in the "Periodic Maintenance" section and then remove fitting. Put pipe dope or teflon tape on the threads and replace. Then follow "Filling the Water Heater" instructions in the "Installing the New Water Heater" section.



⚠ WARNING

Read and understand instruction manual and safety messages before installing, operating or servicing this water heater.

Failure to follow instructions and safety messages could result in death or serious injury.

Instruction Manual must remain with water heater.

REPAIR PARTS LIST

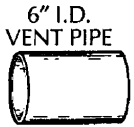

25
27
35
41

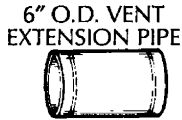

28
33
39



22
31
37
43

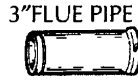

29
34
40



23
26
32
38



24
30
36
42
42
45

STANDARD VENT KIT: 9000687

6" O.D. VENT PIPE EXTENSION

6" I.D. VENT PIPE

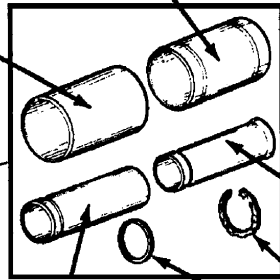

3" FLUE EXTENSION PIPE

O-RING GASKET

ROPE GASKET

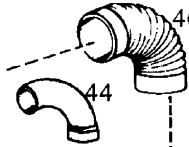
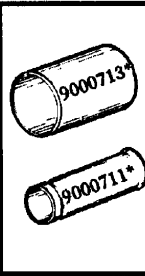

3" FLUE EXTENSION PIPE

6" I.D. VENT PIPE

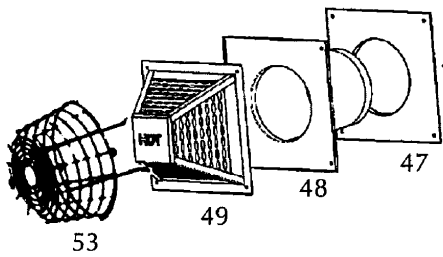

OPTIONAL VENT KITS:

9001246
9001247
9001248

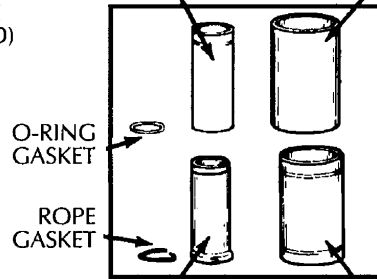

O-RING GASKET

ROPE GASKET

3" FLUE (FLARED)

21
20
19

6" O.D. VENT PIPE EXTENSION

ALTERNATE BROWN-PORCELAIN COATED VENT CAP AND VENT WALL ASSEMBLY

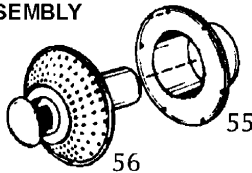

EACH VENT KIT CAN BE USED EITHER HORIZONTALLY OR VERTICALLY, BUT ONLY ONE VENT KIT CAN BE USED HORIZONTALLY AND/OR VERTICALLY.

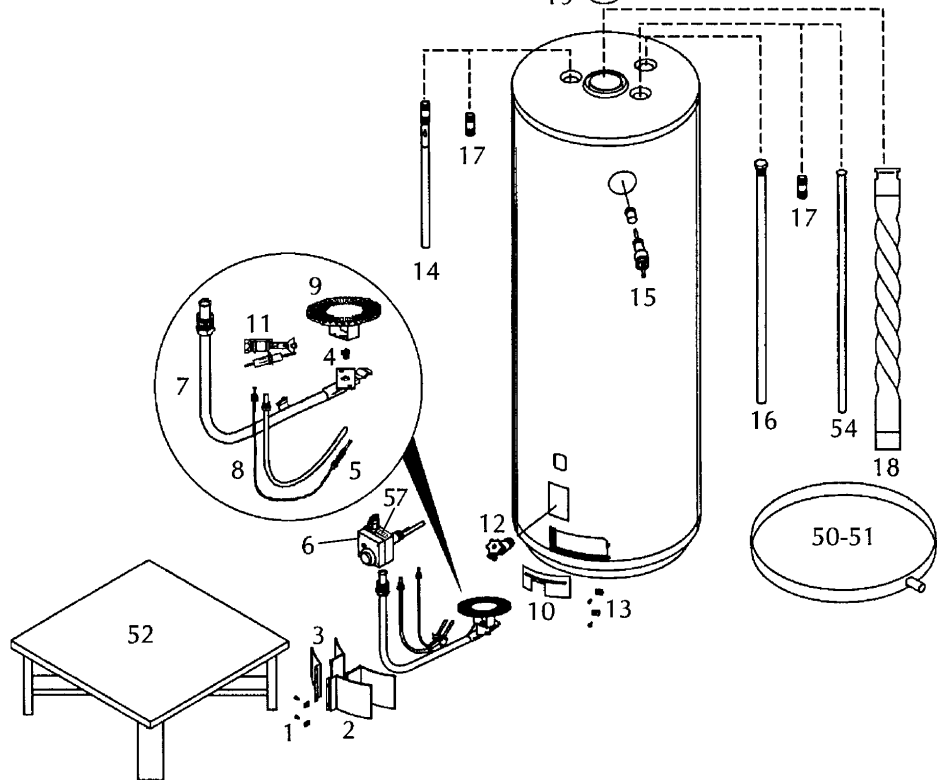

REPAIR PARTS LIST (cont'd.)

KEY #	PARTS DESCRIPTION	GAL. CAP.	40	50	40	50	75
		BTU's in 1000's NAT/L.P.	36/36	38/38	40/40	48/44	55 NAT.
1.	Access Door Clips (Pkg. 2)		9000694	9000694	9000694	9000694	9000694
2.	Right Access Door w/Gasket		9000695	9000695	9000695	9000695	9000695
3.	Left Access Door w/Gasket		9000696	9000696	9000696	9000696	9000696
4.	Burner Orifice (Nat.)		9005165	9005170	9001700	9005171	9001701
	(Drill Size)		#36	#35	#33	1/8	#30
4.	Burner Orifice (Nat.) Hi-Altitude		9005928	9001886	9005165	9001700	9005172
	(Drill Size)		#39	#37	#36	#33	#31
4.	Burner Orifice (L.P.) LHT		9004005	9004005	9002134	9002130	—
	(Drill Size)		#51	#51	#50	#49	
4.	Burner Orifice (L.P.) Hi-Altitude/LHT		9002129	9002129	9004005	9002134	—
	(Drill Size)		#52	#52	#51	#50	
5.	Thermocouple		9000876	9000876	9000876	9000876	9002002
6.	Gas Control Valve (Nat.)		9000249	9000249	9000249	9000249	9000249
6.	Gas Control Valve Propane (L.P.)		9002123	9002123	9002123	9002123	9002123
7.	Gas Manifold (Nat.)		9002413	9002413	9002413	9002413	9003046
7.	Gas Manifold (L.P.)		9002415	9002415	9002415	9002415	—
8.	Pilot Tubing w/Fittings		9000278	9000278	9000278	9000278	9000278
9.	Burner (Nat.)		9002411	9002411	9002411	9002411	9003040
9.	Burner Propane (L.P.)		9002411	9002411	9002411	9000349	—
10.	Inner Door		9000281	9000281	9000281	9000281	9000281
11.	Pilot (Nat.) w/electrode		9003084	9003084	9003084	9003084	9003084
11.	Pilot Propane (L.P.) w/electrode		9003085	9003085	9003085	9003085	—
12.	Drain Valve		9000058	9000058	9000058	9000058	9001588
13.	Jacket Clips (Pkg. 8)		9001305	9001305	9001305	9001305	9001305
14.	Secondary Anode w/Nipple*		9000705	9000705	9000705	9000705	9000705
15.	Temperature-Pressure Relief Valve		9000728	9000728	9000728	9000728	9000728
16.	Anode Rod		9000707	9000279	9000707	9000279	9000734
17.	Nipple		9000399	9000399	9000399	9000399	9002298
18.	Flue Baffle (Nat.)		9000709	9002836	9002837	9001288	9002297
18.	Flue Baffle (L.P.)		9000709	9000806	9001287	9001288	—
19.	Flue Adaptor		—	—	9001289	9001290	9001290
20.	Adaptor Gasket		—	—	9001291	9001292	9001292
21.	Adaptor Plate w/Gasket		—	—	9001293	9001294	9001294
	Standard Kit No. 9000687						
22.	O-Ring Gasket		9000710	9000710	9000710	9000710	9000710
23.	3" I.D. x 9.5" Flue Extension Pipe with Gaskets		9000711	9000711	9000711	9000711	9000711
24.	Rope Gasket		9000712	9000712	9000712	9000712	9000712
25.	3" I.D. x 5 1/2" Vent Extension Pipe Kit AVK-1 No. 9001246		9000713	9000713	9000713	9000713	9000713
26.	3" I.D. x 7 7/8" Flue Extension Pipe with Gaskets		9001280	9001280	9001280	9001280	9001280
27.	6" I.D. x 8 1/8" Vent Pipe		9001277	9001277	9001277	9001277	9001277
28.	6" O.D. x 8 1/8" Vent Extension Pipe		9001274	9001274	9001274	9001274	9001274
29.	3" O.D. x 8 3/8" Flue Pipe		9001283	9001283	9001283	9001283	9001283
30.	Rope Gasket		9000712	9000712	9000712	9000712	9000712
31.	O-Ring Gasket		9000710	9000710	9000710	9000710	9000710

REPAIR PARTS LIST

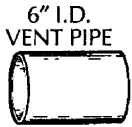

25
27
35
41

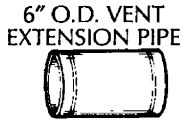

28
33
39



22
31
37
43

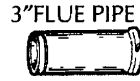

29
34
40



23
26
32
38



24
30
36
42
45

STANDARD VENT KIT: 9000687

6" O.D. VENT PIPE EXTENSION

6" I.D. VENT PIPE

3" FLUE EXTENSION PIPE

3" FLUE (FLARED)

ROPE GASKET

O-RING GASKET

3" FLUE EXTENSION PIPE

6" I.D. VENT PIPE

OPTIONAL VENT KITS:
9001246
9001247
9001248

3" FLUE (FLARED)

6" O.D. VENT PIPE EXTENSION

21
20
19

ALTERNATE BROWN-PORCELAIN COATED VENT CAP AND VENT WALL ASSEMBLY

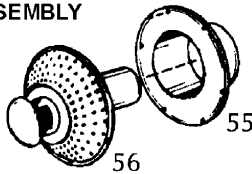

EACH VENT KIT CAN BE USED EITHER HORIZONTALLY OR VERTICALLY, BUT ONLY ONE VENT KIT CAN BE USED HORIZONTALLY AND/OR VERTICALLY.

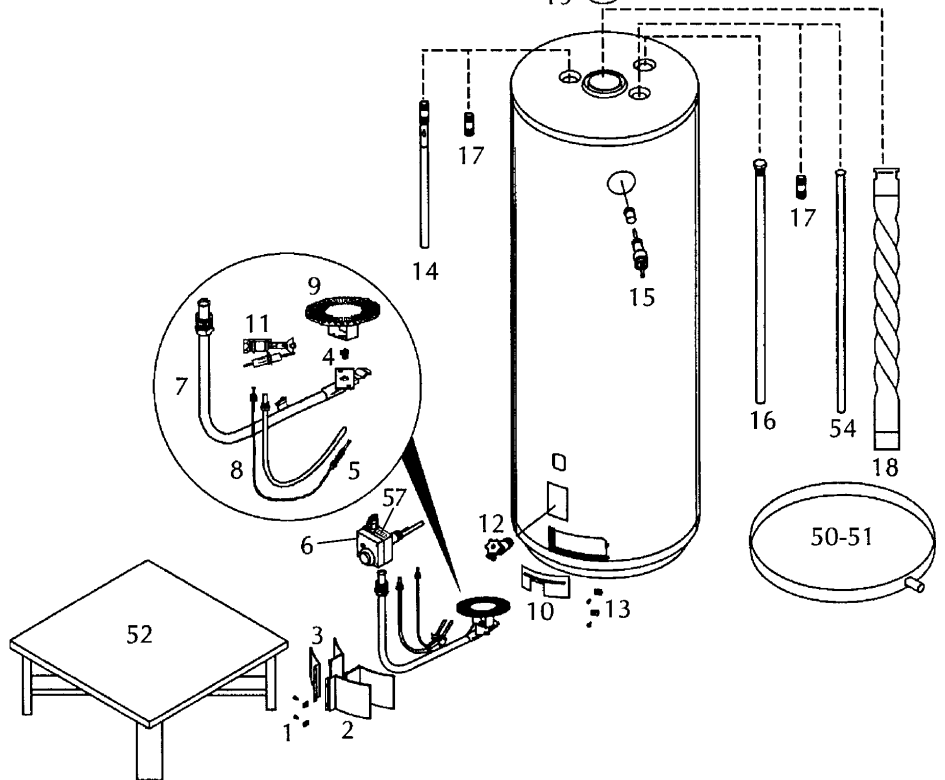

REPAIR PARTS LIST (cont'd.)

KEY #	PARTS DESCRIPTION	GAL. CAP.	40	50	40	50	75
		BTU's in 1000's NAT/L.P.	36/36	38/38	40/40	48/44	55 NAT.
	Kit AVK-2 No. 9001247						
32.	3" I.D. x 13 7/8" Flue Extension Pipe with Gaskets		9001281	9001281	9001281	9001281	9001281
33.	6" O.D. x 13 5/8" Vent Extension Pipe		9001275	9001275	9001275	9001275	9001275
34.	3" O.D. x 13 3/8" Flue Pipe		9001284	9001284	9001284	9001284	9001284
35.	6" I.D. x 13 5/8" Vent Pipe		9001278	9001278	9001278	9001278	9001278
36.	Rope Gasket		9000712	9000712	9000712	9000712	9000712
37.	O-Ring Gasket		9000710	9000710	9000710	9000710	9000710
	Kit AVK-3 No. 9001248						
38.	3" I.D. x 24 3/8" Flue Extension Pipe with Gaskets		9001282	9001282	9001282	9001282	9001282
39.	6" O.D. x 24 3/8" Vent Extension Pipe		9001276	9001276	9001276	9001276	9001276
40.	3" O.D. x 24 3/8" Flue Pipe		9001285	9001285	9001285	9001285	9001285
41.	6" I.D. x 24 3/8" Vent Pipe		9001279	9001279	9001279	9001279	9001279
42.	Rope Gasket		9000712	9000712	9000712	9000712	9000712
43.	O-Ring Gasket		9000710	9000710	9000710	9000710	9000710
44.	3" Flue Elbow		9000718	9000718	9000718	9000718	9000718
45.	Rope Gasket		9000712	9000712	9000712	9000712	9000712
46.	6" Vent Elbow		9000719	9000719	9000719	9000719	9000719
47.	Inside Wall Collar		9003168	9003168	9003168	9003168	9003168
48.	6" Vent Wall Assembly		9003166	9003166	9003166	9003166	9003166
49.	Vent Cap Assembly		9003165	9003165	9003165	9003165	9003165
50.	24" Diameter Drain Pan w/Side Drain		9002769	9002769	9002769	9002769	—
51.	28" Diameter Drain Pan w/Side Drain		—	—	—	—	9001608
52.	24" Base Stand		9001422	9001422	9001422	9001422	—
53.	Wire Grill Protector		9000915	9000915	9000915	9000915	9000915
54.	Dip Tube		*9002365	9001595	*9002365	*9002361	*9001598
55.	6" Vent Wall Assembly		9000724	9000724	9000724	9000724	9000724
56.	Brown-Porcelain Vent Cap Assembly		9000725	9000725	9000725	9000725	9000725
57.	Piezo Ignitor w/Bracket		9003410	9003410	9003410	9003410	9003410

*NOTE: Some models are factory equipped with a special dip tube to retard a build-up of mineral deposits precipitating from the water supply over time. This is not illustrated and is not a replaceable part.

Now that you have purchased this water heater, should a need ever exist for repair parts or service, simply contact the company it was purchased from or direct from the manufacturer listed on the rating plate on the water heater.

Be sure to provide all pertinent facts when you call or visit.

Selling prices will be furnished on request or parts will be shipped at prevailing prices and you will be billed accordingly.

The model number of your water heater will be found on the rating plate located above the gas control valve.

WHEN ORDERING REPAIR PARTS, ALWAYS GIVE THE FOLLOWING INFORMATION:

MODEL NUMBER	TYPE GAS
SERIAL NUMBER	PART DESCRIPTION

THIS IS A REPAIR PARTS LIST, NOT A PACKING LIST.

TROUBLESHOOTING GUIDELINES

These guidelines should be utilized by a qualified service agent.

Problem	Cause	Solution
WATER LEAKS	Improperly sealed, hot or cold supply connection, relief valve, drain valve, or thermostat threads.	Tighten threaded connections.
	Leakage from other appliances or water lines.	Inspect other appliances near water heater.
	Condensation of flue products.	Refer to CONDENSATE.
LEAKING T&P VALVE	Thermal expansion in closed water system.	Install thermal expansion tank (DO NOT plug T&P valve).
	Improperly seated valve.	Check relief valve for proper operation (DO NOT plug T&P valve).
SMELLY ODORS	High sulfate or mineral content in water supply.	Drain and flush heater thoroughly, then refill.
	Bacteria in water supply.	Chlorinate or aerate water supply.
PILOT WILL NOT LIGHT	Gas control knob not positioned correctly.	Refer to LIGHTING INSTRUCTIONS.
	Main gas supply off.	Turn on main gas Shut-off valve.
	Igniter tip more than 1/8" from pilot hood.	Adjust ignitor tip.
	Melted insulation on ignitor wire or shorting of ignitor wire.	Contact a service agency to determine cause.
	Wire disconnected from spark ignitor.	Reconnect wire connector to spark ignitor.
	Broken electrode or electrical wire.	Replace pilot assembly.
	Piezo Ignitor generator fails to operate or malfunctions.	Replace Piezo Ignitor generator.
BURNER WILL NOT STAY LIT	Thermocouple malfunction.	Replace pilot assembly.
	Defective Gas Control.	Replace Gas Control.
PILOT OUTAGE	Dirty pilot burner.	Clean pilot assembly.
	Thermocouple tip is not in contact with pilot flame.	Insert thermocouple correctly.
	Thermocouple malfunction.	Replace pilot assembly.
	Defective Gas Control.	Replace Gas Control.
NOT ENOUGH HOT WATER	Heater not lit or thermostat not on.	Refer to LIGHTING INSTRUCTIONS.
	Thermostat set too low.	Refer to TEMPERATURE REGULATION.
	Heater undersized.	Reduce hot water use.
	Low gas pressure.	Contact your gas supplier.
	Incoming water is unusually cold.	Allow more time for heater to re-heat.
	Leaking hot water pipes or fixtures.	Have plumber check and repair leaks.
	High temperature limit switch activated.	Contact a service agency to determine cause.
WATER TOO HOT	Thermostat set too high.	Refer to TEMPERATURE REGULATION.
WATER HEATER SOUNDS	Condensation dripping on burner.	Refer to CONDENSATE above.
SIZZLING - RUMBLING	Sediment or calcium in bottom of heater tank.	Clean sediment from tank. Refer to DRAINING instructions in Maintenance section of manual.
SOOTING	Improper combustion.	No adjustment available. Contact a service agency to determine cause.
VENT GAS ODORS	Lack of supply air.	
	Improperly installed vent piping.	Contact a service agency to determine cause.
	Downdraft	
	Poor combustion.	

NOTES:

NOTES:

NOTES:
