



2005

Ford F-350 Super Duty

4x4 Manual



Table of contents

Introduction	2
Notice To Utility Vehicle and Truck Owners	3
Vehicle Characteristics	4
Driving On Roadways	6
Driving Off-Road	9
Inspecting and Inflating Your Tires	13
Tire Replacement Requirements	15
Loading Your Vehicle	16
Trailer Towing	19
Maintenance and Modifications	20

All rights reserved. Reproduction by any means, electronic or mechanical including photocopying, recording or by any information storage and retrieval system or translation in whole or part is not permitted without written authorization from Ford Motor Company. Ford may change the contents without notice and without incurring obligation.

Copyright © 2003 Ford Motor Company

Introduction

INTRODUCTION

Welcome to Ford Motor Company's world of Sport Utility Vehicles (SUV) and truck driving! Your new vehicle opens up a completely different and challenging world of travel unlike what you have ever experienced with a conventional car. Most importantly, you'll be able to travel with the safety, comfort and dependability of a Ford-built vehicle.

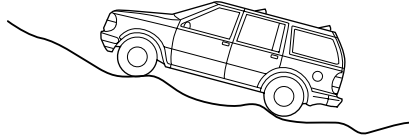

Your vehicle, particularly when loaded, will handle differently than an ordinary passenger car. This is because your vehicle has special design and equipment features for cargo-hauling or off-road operation.

Study this supplement and the "Owner's Guide" for specific information about equipment features and instructions for safe driving. You must also learn and understand the capabilities and limitations of your vehicle through experience. Take it slow and easy until you get to know and understand your vehicle.

Driving at speeds safe for road conditions and the use of safety belts are the best means of avoiding the possibility of accident and serious injury. All occupants must wear the safety belts and children/infants must use appropriate restraints to minimize the risk of injury or ejection.

Ford Motor Company reserves the right at any time to change information provided herein, including specifications, design or testing procedures without incurring obligation.

Notice To Utility Vehicle and Truck Owners

NOTICE TO UTILITY VEHICLE AND TRUCK OWNERS

Utility vehicles and trucks handle differently than passenger cars in the various driving conditions that are encountered on streets, highways and off-road. Utility vehicles and trucks are not designed for cornering at speeds as high as passenger cars any more than low-slung sports cars are designed to perform satisfactorily under off-road conditions.

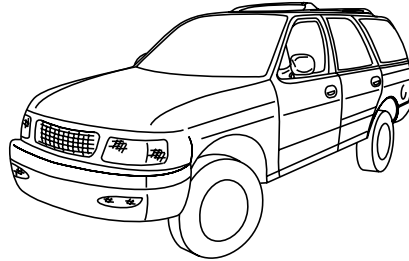

Utility vehicles have a significantly higher rollover rate than other types of vehicles. To reduce the risk of serious injury or death from a rollover or other crash you must:

- Avoid sharp turns and abrupt maneuvers;
- Drive at safe speeds for the conditions;
- Keep tires properly inflated;
- Never overload your vehicle; and
- Make sure every passenger is properly restrained.



In a rollover crash, an unbelted person is significantly more likely to die than a person wearing a seat belt. All occupants must wear safety belts and children/infants must use appropriate restraints to minimize the risk of injury or ejection.

Study this supplement and the “Owner’s Guide” for specific information about equipment features, instructions for safe driving and additional precautions to reduce the risk of an accident or serious injury.

Vehicle Characteristics

VEHICLE CHARACTERISTICS

4WD and AWD Systems

A vehicle equipped with AWD or 4WD (when you select the 4WD mode) has the ability to use all four wheels to power itself. This increases traction which may enable you to safely drive over terrain and road conditions that a conventional two-wheel drive vehicle cannot.

Power is supplied to all four wheels through a transfer case or power transfer unit. 4WD vehicles allow you to select different drive modes as necessary. Information on shifting procedures and maintenance can be found in your "Owner's Guide." You should become thoroughly familiar with this information before you operate your vehicle.

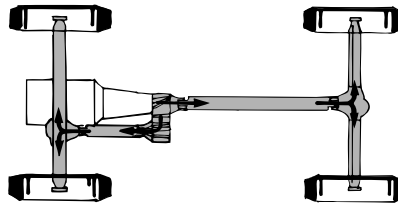

On some 4WD models, the initial shift from two-wheel drive to 4WD while the vehicle is moving can cause a momentary clunk and ratcheting sound. These sounds are normal as the front drivetrain comes up to speed and is not cause for concern.



Do not become overconfident in the ability of 4WD and AWD vehicles. Although a 4WD or AWD vehicle may accelerate better than two-wheel drive vehicle in low traction situations, it won't stop any faster than two-wheel drive vehicles. Always drive at a safe speed.

Vehicle Characteristics

How your vehicle differs from other vehicles

SUV and trucks can differ from some other vehicles in a few noticeable ways. Your vehicle may be:

- Higher – to allow higher load carrying capacity and to allow it to travel over rough terrain without getting hung up or damaging underbody components.
- Shorter – to give it the capability to approach inclines and drive over the crest of a hill without getting hung up or damaging underbody components. All other things held equal, a shorter wheelbase may make your vehicle quicker to respond to steering inputs than a vehicle with a longer wheelbase.
- Narrower — to provide greater maneuverability in tight spaces, particularly in off-road use.

As a result of the above dimensional differences, SUV's and trucks often will have a higher center of gravity and a greater difference in center of gravity between the loaded and unloaded condition.

These differences that make your vehicle so versatile also make it handle differently than an ordinary passenger car.

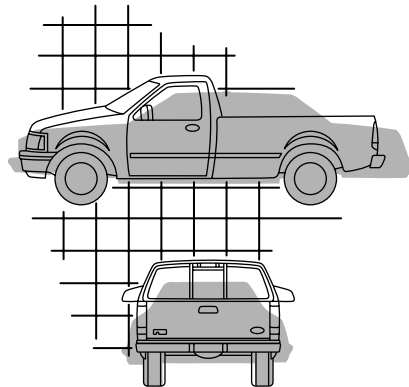
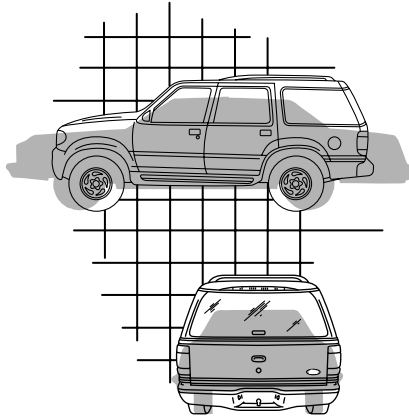

Driving On Roadways

DRIVING ON ROADWAYS



Vehicles with a higher center of gravity such as utility vehicles and trucks handle differently than vehicles with a lower center of gravity. Utility vehicles and trucks are not designed for cornering at speeds as high as passenger cars any more than low-slung sports cars are designed to perform satisfactorily under off-road conditions. Avoid sharp turns, excessive speed or abrupt maneuvers in these vehicles. Failure to drive cautiously could result in an increased risk of loss of vehicle control, vehicle rollover, personal injury and death.

Basic operating principles

- Drive slower in strong crosswinds which can affect the normal steering characteristics of your vehicle.
- Be extremely careful when driving on pavement made slippery by loose sand, water, gravel, snow or ice.
- Do not use 4WD on dry, hard surfaced roads (except models equipped with Auto 4WD or AWD). This may damage the drivelines and axles.

If your vehicle goes off the edge of the pavement

- If your vehicle goes off the edge of the pavement, slow down and avoid severe brake application or aggressive steering. Ease the vehicle back onto the pavement only after reducing your speed. Do not turn the steering wheel too sharply while returning to the road surface.

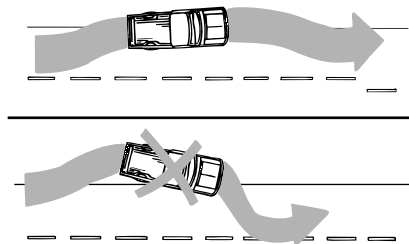

- If you have the space, it may be safer to stay on the apron or shoulder of the road and slow down gradually before returning to the pavement. You may lose control if you do not slow down or if you turn the steering wheel too sharply or abruptly.
- It often may be less risky to strike small inanimate objects, (such as highway reflectors), and incur minor damage to your vehicle rather than attempt a sudden return to the pavement which could cause the vehicle to slide sideways out of control or rollover. Remember, your safety and the safety of others should be your primary concern.

Driving On Roadways

Emergency maneuvers

- In an emergency situation where a sudden sharp turn must be made, remember to avoid “over-driving” your vehicle, i.e., turn the steering wheel only as rapidly and as far as required to avoid the emergency. Avoid abrupt steering, acceleration or braking which could increase the risk of loss of vehicle control or vehicle rollover. Instead, smooth variations of the accelerator and/or brake pedal pressure should be utilized if changes in vehicle speed are called for. Use all available road surface to return the vehicle to a safe direction of travel.
- In the event of an emergency stop, avoid skidding the tires and do not attempt any sharp steering wheel movements.
- If the vehicle goes from one type of road surface to another (i.e., from concrete to gravel), there will be a change in the way the vehicle responds in steering, acceleration or braking. Again, avoid abrupt inputs steering or braking inputs.

Snow and ice

Your 4WD or AWD vehicle will have advantages over two-wheel drive vehicles in snow and on ice by providing increased driving traction. However, if you suddenly change speed or direction, you may lose traction and in turn, control as is the case with all vehicles. 4WD and AWD vehicles can slide on slippery roads just like any other vehicle. Should the rear end of the vehicle start to slide while cornering on snowy or icy roads, turn the steering wheel in the direction of the slide until you regain control. Avoid sudden braking as well. Although a 4WD or AWD vehicle may accelerate better than a two-wheel drive vehicle in snow and ice, it won't stop any faster, because as in two-wheel drive vehicles, braking occurs at all four wheels. Do not become overconfident in the ability of 4WD and AWD vehicles to compensate for aggressive driving maneuvers in poor road conditions.

Make sure you allow sufficient distance between you and other vehicles for stopping. In emergency stopping situations, avoid locking the wheels.

- For vehicles without anti-lock brakes, use a “squeeze” technique: push on the brake pedal with a steadily increasing force which allows the wheels to brake yet continue to roll so that you may steer in the direction you want to travel. If you lock the wheels, release the brake pedal and repeat the squeeze technique.

Driving On Roadways

- For vehicles with anti-lock brakes, apply and hold the brake firmly. Do not “pump” the brakes. During hard stopping or stopping on slippery surfaces, you may feel or hear a pulsing or vibration in the brake pedal. Do not be alarmed because this is your anti-lock brake system working. See your “Owner’s Guide” for additional information on the operation of the anti-lock brake system.

Parking

Before leaving the driver’s seat, make sure that the gearshift is engaged in P (Park) with an automatic transmission or either 1 (First) or R (Reverse) with a manual transmission. Set the parking brake fully, shut off the ignition and remove the key.

Some 4WD vehicles include a Neutral mode. When the transfer case is in the N (Neutral) position, the engine and transmission are disconnected from the rest of the driveline. Therefore, the vehicle is free to roll even if the automatic transmission is in P (Park) or the manual transmission is in gear.



Do not leave the vehicle unattended with the transfer case in N (Neutral) position. Always set the parking brake fully and turn off the ignition when leaving the vehicle. If you do not follow these precautions your vehicle may move unexpectedly and injure someone.

Driving Off-Road

DRIVING OFF-ROAD

“Tread Lightly” is an educational program designed to increase public awareness of land-use regulations and responsibilities in our nations wilderness areas.



Ford joins the U. S. Forest Service and the Bureau of Land Management in encouraging you to help preserve our national forest and other public and private lands by “treading lightly”.

Driving off-road requires good judgment to avoid personal injury and vehicle damage from concealed objects such as rocks and stumps. Know the terrain or examine maps of the area before driving off road. Map out your route before driving in the area. To maintain steering and braking control of your vehicle, you must have all four wheels on the ground and they must be rolling, not sliding or spinning. To avoid loss of control, maintain a firm grip on the steering wheel, especially in rough terrain.



Sudden changes in terrain can result in abrupt steering wheel motion. To maintain better control and avoid injury to your hand or wrist, grip the steering wheel from the outside. Do not grip the spokes.

Driving on sand

When driving over sand, try to keep all four wheels on the most solid area of the trail. Avoid reducing the tire pressure. Instead, shift to a lower gear and drive steadily through the terrain. Apply the accelerator slowly and avoid spinning the wheels.



Avoid reducing tire pressure. Operating your vehicle with below the recommended tire pressure can increase the risk of loss of vehicle control, vehicle rollover, personal injury and death. If you choose to reduce the tire pressure for off-road operation, make sure you re-inflate the tires as soon as possible.

Avoid excessive speed because vehicle momentum can work against you and cause the vehicle to become stuck to the point that assistance may be required from another vehicle. Remember, you may be able to back out the way you came if you proceed with caution.

Driving Off-Road

Driving in mud

Be cautious of sudden changes in vehicle speed or direction when you are driving in mud. Even 4WD and AWD vehicles can lose traction in slick mud. As when you are driving over sand, apply the accelerator slowly and avoid spinning your wheels. If the rear end of the vehicle does slide while cornering, steer in the direction of the slide until you regain control of the vehicle.

After driving through mud, clean off residue stuck to rotating tires, wheels and driveshafts. Excess mud stuck on tires, wheels and rotating driveshafts causes an imbalance that could damage vehicle components.

Driving through water

Before driving through water, determine the depth. Avoid water higher than the center of the wheel or hubcap. Proceed slowly to avoid splashing; if the ignition system gets wet, the vehicle may stall.



Once through water, always try the brakes. Wet brakes do not stop the vehicle as effectively as dry brakes. You can dry the brakes faster by driving the vehicle slowly while applying light pressure on the brake pedal.

Driving in deep snow

4WD and AWD vehicles are unique in that they can be driven in deep snow that would stop a conventional two-wheel drive vehicle. Shift to a low gear and maintain steady pressure on the accelerator. This will help prevent spinning the wheels while maintaining sufficient momentum to keep from bogging down. Using tire chains will also help.

Never drive with chains on the front tires of 4WD or AWD vehicles without also putting them on the rear tires. This could cause the rear of the vehicle to slide and swing around.

Driving on hills



Operating your vehicle off-road on slopes or hills requires safe off-road driving practices. Read and follow these safe off-road driving practices to reduce the risk of loss of vehicle control, vehicle rollover, serious injury or death.

Driving Off-Road

Although natural obstacles may make it necessary to travel diagonally up or down a hill or steep incline, you should always try to drive straight up or straight down. **Avoid driving crosswise or turning on steep slopes or hills.** A danger lies in losing traction, slipping sideways and possibly rolling over. Whenever driving on a hill, determine beforehand the route you will use. Do not drive over the crest of a hill without seeing what conditions are on the other side. Do not drive in reverse over a hill without the aid of an observer.

When climbing a steep slope or hill, start in a lower gear rather than downshifting to a lower gear from a higher gear once the ascent has started. This reduces strain on the engine and the possibility of stalling. If you do stall out, do not try to turn around because you might induce a rollover. It is better to back down to a safe location.

Apply just enough power to the wheels to climb the hill. Too much power can cause the tires to slip, spin or lose traction, resulting in loss of vehicle control.

Descend a hill in the same gear you would use to climb up the hill to avoid excessive brake application and brake overheating. Do not descend in neutral. Disengage overdrive or manually shift to a lower gear. When descending a steep hill, avoid sudden hard braking as you could lose control. In a vehicle without four wheel anti-lock brakes, if you lock up the front brakes, the front wheels can't roll and if they aren't rolling, you won't be able to steer. The front wheels have to be rolling in order to steer the vehicle. Rapid pumping of the brake pedal will help you slow the vehicle and still maintain steering control. If your vehicle has four wheel anti-lock brakes, apply and hold the brakes firmly. Do not "pump" the brakes.

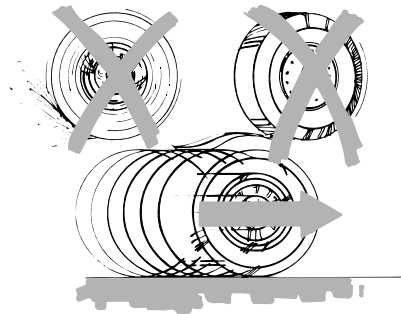
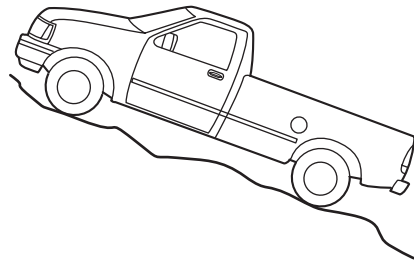

Driving Off-Road

Parking

Before leaving the driver's seat, make sure that the gearshift is engaged in P (Park) with an automatic transmission or either 1 (First) or R (Reverse) with a manual transmission. Set the parking brake fully, shut off the ignition and remove the key.

Some 4WD vehicles include a Neutral mode. When the transfer case is in the N (Neutral) position, the engine and transmission are disconnected from the rest of the driveline. Therefore, the vehicle is free to roll even if the automatic transmission is in P (Park) or the manual transmission is in gear.



Do not leave the vehicle unattended with the transfer case in N (Neutral) position. Always set the parking brake fully and turn off the ignition when leaving the vehicle. If you do not follow these precautions your vehicle may move unexpectedly and injure someone.

Inspecting and Inflating Your Tires

INSPECTING AND INFLATING YOUR TIRES

Safe operation of your vehicle requires that your tires are properly inflated. Remember that a tire can lose up to half of its air pressure without appearing flat.

Every day before you drive, check your tires. If one looks lower than the others, use a tire gauge to check pressure of all tires, and adjust if required.

At least once a month and before long trips, inspect each tire and check the tire pressure with a tire gauge (including spare). Inflate all tires to the inflation pressure recommended by Ford Motor Company.

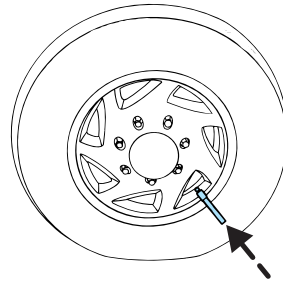

Inspecting your tires

Periodically inspect the tire treads for uneven or excessive wear and remove stones, nails, glass or other objects that may be wedged in the tread grooves. Check for holes or cuts that may permit air leakage from the tire and make necessary repairs.

Also inspect the tire sidewalls for cuts, bruises and other damage. If internal damage to the tire is suspected, have the tire demounted and inspected in case it needs to be repaired or replaced. For your safety, tires that are damaged should not be used because they are more likely to blow out or fail. Tires can be damaged during off-road use, so inspection after off-road use is also recommended.

Inflating Your Tires

Use a tire gauge to check the tire inflation pressure, including the spare, at least monthly and before long trips. You are strongly urged to buy a reliable tire pressure gauge, as automatic service station gauges may be inaccurate. Ford recommends the use of a digital or dial type tire pressure gauge rather than a stick type tire pressure gauge.

Always inflate your tires to the Ford recommended inflation pressure even if it is less than the maximum inflation pressure information found on the tire. The Ford recommended tire inflation pressure is found on the tire and loading information label or certification label attached to the left front door lock facing or door latch post pillar. Failure to follow tire pressure recommendations can cause uneven treadwear patterns and adversely affect the way your vehicle handles.

Inspecting and Inflating Your Tires

Maximum Permissible Inflation Pressure

Tire manufactures maximum permissible pressure and/or the pressure at which the maximum load can be carried by the tire. This pressure is normally higher than the manufacturer's recommended cold inflation pressure which can be found on either the tire label or certification label which is located on the structure by the trailing edge of the driver's door or the edge of the driver's door. The cold inflation pressure should never be set lower than the recommended pressure on the vehicle label.

Note: You may not find this information on all tires because it is not required by federal law.

The tire suppliers may have additional markings, notes or warnings such as standard load, radial tubeless, etc.

Tires can slowly lose pressure due to normal use or due to changes in weather. For example, a 10 degree temperature drop can cause a corresponding drop of 7 kPa (1 psi) in tire inflation pressure.



Maintain proper tire inflation pressure. Under-inflation is the most common cause of tire failures. Under-inflation increases sidewall flexing and rolling resistance, resulting in heat buildup and internal damage to the tire. Operating your vehicle with under-inflated tires may result in severe tire cracking, tread separation or tire "blowout", which can lead to loss of vehicle control, vehicle rollover, serious injury or death.

The Ford recommended inflation pressure is based on cold tire pressure. Tire pressure increases even after driving short distances, so try to check tire inflation pressures before driving. If you are checking tire pressure when the tire is hot, (i.e. driven more than 1.6 km [1mile]), never "bleed" or reduce air pressure. A hot tire with a tire pressure at or below recommended cold inflation pressure could be significantly under-inflated.

To check the pressure in your tire(s):

1. Make sure the tires are cool, meaning they are not hot from driving even a mile.

Note: If you have to drive a distance to get air for your tire(s), check and record the tire pressure first and add the appropriate air pressure when you get to the pump. It is normal for tires to heat up and the air pressure inside to go up as you drive. Never "bleed" or reduce air pressure when tires are hot.

2. Remove the cap from the valve on one tire, then firmly press the tire gauge onto the valve.

Tire Replacement Requirements

3. Add air to reach the Ford recommended air pressure.

Note: If you overfill the tire, release air by pushing on the metal stem in the center of the valve. Then recheck the pressure with your tire gauge.

4. Replace the valve cap.

5. Repeat this procedure for each tire, including the spare.

Note: Some spare tires require higher inflation pressure than the other tires.

6. Visually inspect the tires to make sure there are no nails or other objects embedded that could poke a hole in the tire and cause an air leak.

7. Check the sidewalls to make sure there are no gouges, cuts, bulges or other irregularities.

TIRE REPLACEMENT REQUIREMENTS

Your vehicle is equipped with tires designed to provide safe ride and handling capability.



Only use replacement tires and wheels that are the same size and type (such as P-metric versus LT-metric or all-season versus all-terrain) as those originally provided by Ford. Use of any tire or wheel not recommended by Ford can affect the safety and performance of your vehicle, which could result in an increased risk of loss of vehicle control, vehicle rollover, personal injury and death. Additionally the use of non-recommended tires and wheels could cause steering, suspension, axle or transfer case/power transfer unit failure. See your Owner Guide for additional information. If you have questions regarding tire replacement, see an authorized Ford or Lincoln/Mercury dealer.

Make sure all tires and wheels on the vehicle are of the same size, type, tread design, brand, load-carrying capacity and speed rating because it can affect the safety and performance of your vehicle, which could result in an increased risk of loss of vehicle control, vehicle rollover, personal injury and death.

Loading Your Vehicle

LOADING YOUR VEHICLE

Passenger and cargo load limits

The combined weight of all occupants and all cargo (including added accessories) must not exceed the **maximum payload** for your vehicle. The maximum payload for your vehicle can be found on the tire label on the driver's door or door pillar. Look for statement "THE COMBINED WEIGHT OF OCCUPANTS AND CARGO SHOULD NEVER EXCEED XXX KG OR XXX LBS" to determine your vehicle's maximum payload.



The appropriate loading capacity of your vehicle can be limited either by volume capacity (how much space is available) or by payload capacity (how much weight the vehicle should carry). Once you have reached the maximum payload of your vehicle, do not add more cargo, even if there is space available. Overloading or improperly loading your vehicle can contribute to loss of vehicle control and vehicle rollover.

In addition to **maximum payload**, additional loading terms and weight ratings are very important, particularly when towing a trailer or when a heavy accessory such as a snowplow has been added to the vehicle. Other terms related to loading include **base curb weight**, **gross vehicle weight rating** (GVWR), **gross axle weight rating** (GAWR), **gross combined weight rating** (GCWR). Refer to your "Owner's Guide" for additional information regarding these terms and maximum safe weight limits.

Effects of improperly loading or overloading your vehicle

Improper weight distribution and exceeding the maximum payload can have serious consequences in terms of passenger safety, including damage to the suspension system, springs, and shock absorbers, reduced braking capability, handling or steering problems, irregular tire wear, tire failure or other damage.



Loaded vehicles, with a higher center of gravity, may handle differently than unloaded vehicles. Do not overload your vehicle and use extra precautions, such as driving at slower speeds, avoiding abrupt steering changes and allowing for increased stopping distance, when driving a heavily loaded vehicle. Over loading or loading the vehicle improperly can deteriorate handling capability and contribute to loss of vehicle control and vehicle rollover.

Loading Your Vehicle

Loading and securing cargo

When using your vehicle to haul cargo, make sure it is properly loaded to help ensure safe handling of the vehicle. You should tie down or restrain items in the cargo area so that they will not come loose and create the risk of injury in a crash. Cargo should be evenly distributed over the floor of the cargo area, with the heaviest cargo on the bottom and ahead of the rear axle.

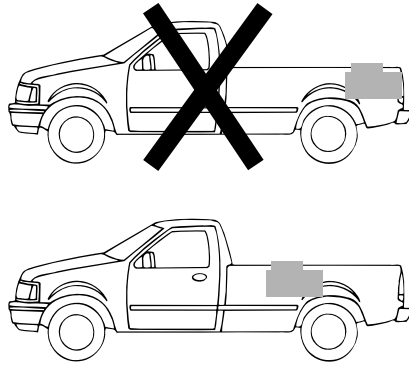

Do not allow people to ride in the cargo area of your vehicle. People who are not riding in seats with their safety belts fastened are much more likely to be injured or killed in a collision.

Loading cargo on the roof

Cargo placed on the roof will tend to make your vehicle more top heavy, causing it to lean more in corners and creating a greater possibility of vehicle rollover. If you must haul cargo on the roof of the vehicle, use extra caution when loading the vehicle and when driving. Cargo on the roof rack should be properly secured and evenly distributed over the roof rack area, with the heaviest cargo on the bottom, near the front of the roof rack area. Any load placed on the roof rack should not exceed the maximum load shown on the roof rack's label.

Truck camper loading

When the vehicle is used to carry a slide-in camper, the total cargo load of the truck consists of the manufacturer's camper weight figure, the weight of installed additional camper equipment not included in the manufacturer's camper weight figure, the weight of the camper cargo, and the weight of all the passengers and cargo in your vehicle.

Loading Your Vehicle

The total cargo load should not exceed the truck's cargo weight rating and the camper's center of gravity should fall within the truck's recommended center of gravity zone when installed. For more information refer to your truck camper loading label.



Do not allow people to ride in a slide-in camper. People who are not riding in seats with their safety belts fastened are much more likely to be injured or killed in a collision.

Trailer Towing

TRAILER TOWING

Your vehicle may be equipped for towing trailers (or may require a trailer tow package). Before you operate your vehicle with a trailer, make sure that you comply with the guidelines in the “RV & Trailer Towing Guide”. The combined total weight of the vehicle and trailer must be less than or equal to the recommended Gross Combination Weight Rating (GCWR) and be properly balanced and secured. Refer to “RV & Trailer Towing Guide,” the “Owner’s Guide” or see an authorized Ford or Lincoln/Mercury Dealer for additional information.

Maintenance and Modifications

MAINTENANCE AND MODIFICATIONS

The suspension and steering systems on your vehicle have been carefully designed to provide safe, predictable performance and durable load carrying capability. Do not make modifications such as adding or removing parts (such as lift kits or stabilizer bars) or using replacement parts not equivalent to the original factory equipment because these modifications can affect the safety of your vehicle.



Do not use “aftermarket lift kits” or other suspension modifications. “Aftermarket lift kits” could adversely affect the vehicle’s handling characteristics, which could result in an increased risk of loss of vehicle control, vehicle rollover, personal injury and death.

Any modifications to a vehicle that raise the center of gravity can make it easier to induce vehicle rollover. Ford recommends that you take extra precautions, such as driving at lower speeds, avoiding abrupt steering changes and allowing for increased stopping distance, for any vehicle equipped with a high load (for example, roof racks).

Failure to maintain your vehicle properly may void the warranty, increase your repair cost, reduce vehicle performance and operational capabilities and adversely affect driver and passenger safety. Frequent inspection of vehicle chassis and powertrain components is recommended if the vehicle is subjected to heavy off-road usage. Refer to the “Owner’s Guide” and “Service Guide” for proper maintenance instructions and schedules.

